



**WELLS BLOOMFIELD, LLC**  
2 ERIK CIRCLE, P. O. Box 280 Verdi, NV 89439  
telephone: 775-689-5703  
fax: 775-689-5976  
[www.wellsbloomfield.com](http://www.wellsbloomfield.com)

506



Model  
WVOC-4HF

## OPERATION MANUAL

## WVOC- 4 SERIES

CONVECTION  
OVEN  
and  
4 HOTPLATE  
COOKTOP  
with  
UNIVERSAL  
HOOD

**MODELS:**  
**WVOC-4HF**  
**WVOC-4HS**

Includes  
**INSTALLATION**  
**USE & CARE**

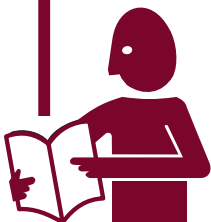

### **IMPORTANT: DO NOT DISCARD THIS MANUAL**

This manual is considered to be part of the appliance and is to be given to the OWNER or MANAGER of the restaurant, or to the person responsible for TRAINING OPERATORS of this appliance. Additional manuals are available from your WELLS DEALER.

**THIS MANUAL MUST BE READ AND UNDERSTOOD BY ALL PERSONS USING OR INSTALLING THIS APPLIANCE.** Contact your WELLS DEALER if you have any questions concerning installation, operation or maintenance of this equipment.

PRINTED IN UNITED STATES OF AMERICA

## LIMITED WARRANTY STATEMENT

Unless otherwise specified, all commercial cooking equipment manufactured by WELLS BLOOMFIELD, LLC is warranted against defects in materials and workmanship for a period of one year from the date of original installation or 18 months from the date of shipment from our factory, whichever comes first, and is for the benefit of the original purchaser only.

THIS WARRANTY IS THE COMPLETE AND ONLY WARRANTY, EXPRESSED OR IMPLIED IN LAW OR IN FACT, INCLUDING BUT NOT LIMITED TO, WARRANTIES OF MERCHANTABILITY OR FITNESS FOR ANY PARTICULAR PURPOSE, AND/OR FOR DIRECT, INDIRECT OR CONSEQUENTIAL DAMAGES IN CONNECTION WITH WELLS BLOOMFIELD PRODUCTS. This warranty is void if it is determined that, upon inspection by an authorized service agency, the equipment has been modified, misused, misapplied, improperly installed, or damaged in transit or by fire, flood or act of God. It also does not apply if the serial nameplate has been removed, or if service is performed by unauthorized personnel. The prices charged by Wells Bloomfield for its products are

based upon the limitations in this warranty. Seller's obligation under this warranty is limited to the repair of defects without charge by a Wells Bloomfield factory authorized service agency or one of its sub-service agencies. This service will be provided on customer's premises for non-portable models. Portable models (a device with a cord and plug) must be taken or shipped to the closest authorized service agency, transportation charges prepaid, for service. In addition to restrictions contained in this warranty, specific limitations are shown in the Service Policy and Procedure Guide. Wells Bloomfield authorized service agencies are located in principal cities. This warranty is valid in the United States and Canada and void elsewhere. Please consult your classified telephone directory, your foodservice equipment dealer or contact:

**Service Department, Wells Bloomfield, LLC  
P.O. Box 280, Verdi, Nevada 89439  
phone (775) 689-5707 or fax (775) 689-5976**

for information and other details concerning warranty.

## SERVICE POLICY AND PROCEDURE GUIDE and ADDITIONAL WARRANTY EXCLUSIONS

1. Resetting of safety thermostats, circuit breakers, over load protectors, and/or fuse replacements are **not** covered by this warranty unless warranted conditions are the cause.
2. All problems due to operation at **voltages or phase other than specified on equipment nameplates** are **not** covered by this warranty. Conversion to correct voltage and/or phase must be the customer's responsibility.
3. All problems due to **electrical connections not made in accordance with electrical code requirements and wiring diagrams** supplied with the equipment are **not** covered by this warranty.
4. Replacement of items **subject to normal wear**, to include such items as knobs, light bulbs; and, normal maintenance functions including adjustments of thermostats, adjustment of micro switches and replacement of fuses and indicating lights are **not** covered by warranty.
5. Damage to electrical cords and/or plug due to exposure to excessive heat are **not** covered by this warranty.
6. Full use, care, and maintenance instructions supplied with each machine. Noted maintenance and preventative maintenance items, such as servicing and cleaning schedules, are customer responsibility. Those miscellaneous adjustments noted are customer responsibility. Proper attention to preventative maintenance and scheduled maintenance procedures will prolong the life of the appliance.
7. Travel mileage is limited to **sixty (60) miles** from an Authorized Service Agency or one of its sub-service agencies.
8. All labor shall be performed during regular working hours. Overtime premium will be charged to the buyer.
9. All genuine Wells replacement parts are warranted for ninety (90) days from date of purchase on non-warranty equipment. This parts warranty is limited only to replacement of the defective part(s). **Any use of non-genuine Wells parts completely voids any warranty.**
10. Installation, labor, and job check-outs are **not** considered warranty and are thus **not** covered by this warranty.
11. Charges incurred by delays, waiting time or operating restrictions that hinder the service technician's ability to perform service are **not** covered by warranty. This includes institutional and correctional facilities.

## SHIPPING DAMAGE CLAIM PROCEDURE

**NOTE:** For your protection, please note that equipment in this shipment was carefully inspected and packaged by skilled personnel before leaving the factory. Upon acceptance of this shipment, the transportation company assumes full responsibility for its safe delivery.

### IF SHIPMENT ARRIVES DAMAGED:

1. **VISIBLE LOSS OR DAMAGE:** Be certain that any visible loss or damage is noted on the freight bill or express receipt, and that the note of loss or damage is signed by the delivery person.
2. **FILE CLAIM FOR DAMAGE IMMEDIATELY:** Regardless of the extent of the damage.

3. **CONCEALED LOSS OR DAMAGE:** if damage is unnoticed until the merchandise is unpacked, notify the transportation company or carrier immediately, and file "CONCEALED DAMAGE" claim with them. This should be done within fifteen (15) days from the date the delivery was made to you. Be sure to retain the container for inspection.

Wells Bloomfield cannot assume liability for damage or loss incurred in transit. We will, however, at your request, supply you with the necessary documents to support your claim.

## TABLE OF CONTENTS

WARRANTY .....	xi
SPECIFICATIONS .....	1
FEATURES & OPERATING CONTROLS .....	2
PRECAUTIONS & GENERAL INFORMATION .....	6
AGENCY LISTING INFORMATION .....	7
INSTALLATION .....	8
OPERATION .....	13
CLEANING INSTRUCTIONS .....	18
TROUBLESHOOTING SUGGESTIONS .....	22
MAINTENANCE INSTRUCTIONS .....	23
MSDS (Ansulex Low pH) .....	26
MAINTENANCE SCHEDULES .....	28
PARTS & SERVICE .....	31
CUSTOMER SERVICE DATA .....	31

## INTRODUCTION

Thank You for purchasing this Wells Bloomfield appliance.

Proper installation, professional operation and consistent maintenance of this appliance will ensure that it gives you the very best performance and a long, economical service life.

This manual contains the information needed to properly install this appliance, and to use and care for the appliance in a manner which will ensure its optimum performance.

## SPECIFICATIONS

MODEL	VOLTS	WATTS	AMPS 3 $\phi$			AMPS 1 $\phi$
			L1	L2	L3	
WVOC-4HF	208	11,500	32	31	26	n/a
	240	14,100	36	35	30	n/a
WVOC-4HS	208	12,500	36	35	34	n/a
	240	16,500	41	40	39	n/a

Minimum clearances required from unit to nearest combustible surface or object.

	BACK	SIDE	BOTTOM	TOP
inches	n/a	6	6	19
millimeters	n/a	152	152	483

# FEATURES & OPERATING CONTROLS

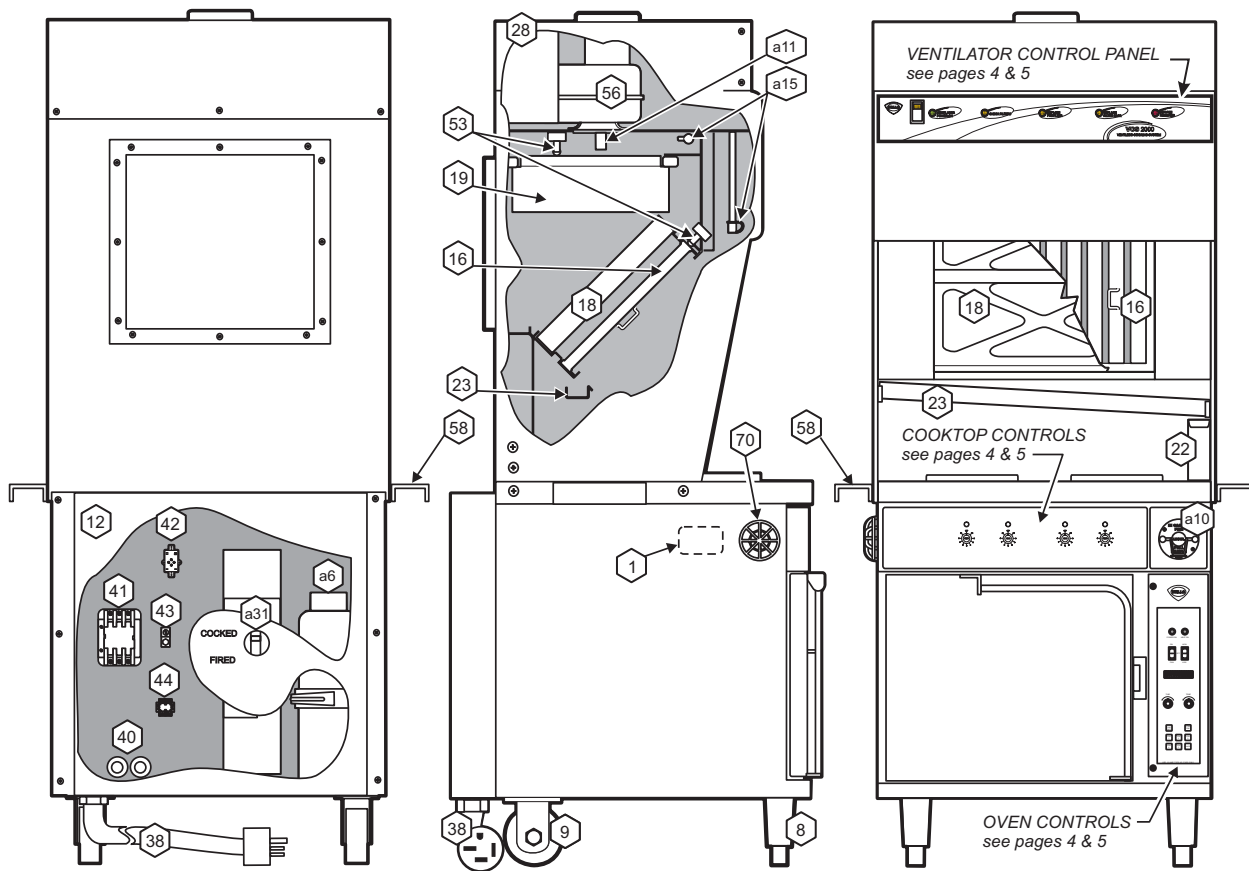

Fig. 1 Ventilator Section Features & Operating Controls

M506 p/n 304964 OpManual WVOC-4 Series Ventless Hopplate Cooktop Convection Oven

## FEATURES & OPERATING CONTROLS (continued)

### VENTILATOR SECTION

ITEM	DESCRIPTION	COMMENT
1.	NAMEPLATE	Gives Manufacturer, Model and Serial Number information. Also lists electrical specifications.
a6.	FIRE SUPPRESSION AGENT TANK (1.5 gal.)	Container for Ansul <sup>TM</sup> Low-pH liquid fire suppression liquid.
8.	ADJUSTABLE (FRONT) LEG	Allows the unit to be leveled.
9.	RIGID (REAR) CASTER	Allows the unit to be easily positioned by lifting the front of the unit slightly.
a10.	MANUAL PULL STATION	Provides a means of manual activation of the fire suppression system. <b>PULL ONLY IN CASE OF FIRE!</b>
a11.	FUSIBLE LINKS	Automatically activates fire suppression system in the event of fire on the cooktop.
12.	LOWER REAR ACCESS PANEL	Allows access to Ansul <sup>®</sup> fire suppression agent tank (a6) and controls also access to main power contactor (41).
a15.	DISCHARGE NOZZLE	Fire suppression media discharges here (2 places).
16.	GREASE BAFFLE	Extracts and drains most grease and moisture from the air flow.
18.	PRE-FILTER ASSEMBLY	Comprises the PRE-FILTER FRAME and a replaceable PRE-FILTER. Stops larger particles of grease from reaching the FILTER PACK for reduced maintenance costs.
19.	HEPA/CHARCOAL FILTER PACK	Stops most grease and smoke particles. Also assists in some cooking odor removal.
22.	GREASE CUP	Collects grease/moisture drained from grease trough (23).
23.	GREASE TROUGH	Directs grease/moisture removed by grease baffle to grease cup.
28.	VENTILATOR EXHAUST DUCT	Exit point for ventilator airflow - on top left rear of unit. <b>DO NOT BLOCK</b>
a31.	STATUS INDICATOR	Displays status of fire suppression system ( <i>COCKED - FIRED</i> ) If <i>FIRED</i> , a buzzer will sound continuously.
38.	POWER CORD	6' cord and cap. Plug for NEMA 15-60R (receptacle by user).
40.	FUSES	Provide over-current protection of cooking appliance.
41.	POWER CONTACTOR	Energizes cooktop only while ventilator section is sensed as operational.
42.	BUILDING FIRE ALARM RELAY	Reports fire alarm condition to building fire management system.
43.	GROUND LUG	Ground wire of power cord connects here.
44.	INTERLOCK TERMINAL	Provides connection for shut-down control by building fire management system.
53.	FILTER INTERLOCK SWITCHES	Proper installation of grease baffle and filter pack close these switches in ventilator sensor circuit. Provides air movement for ventilation.
56.	VENTILATOR FAN	Provides air movement for ventilation.
58.	SIDE SPACERS	Maintain required 6: spacing from combustible surfaces.
70.	COOLING FAN	Provides cooling for cooktop controls.

## FEATURES & OPERATING CONTROLS (continued)

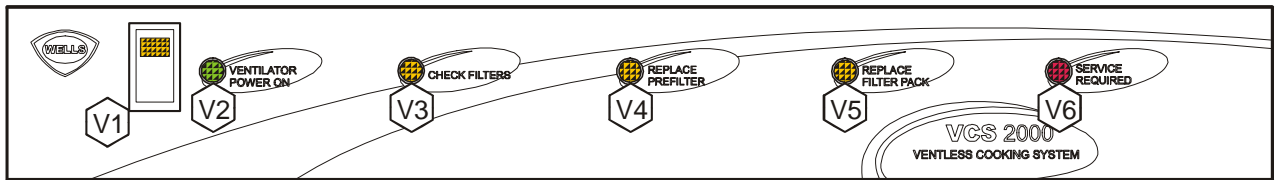

Fig. 2 Ventilator Section Controls & Indicator Lights

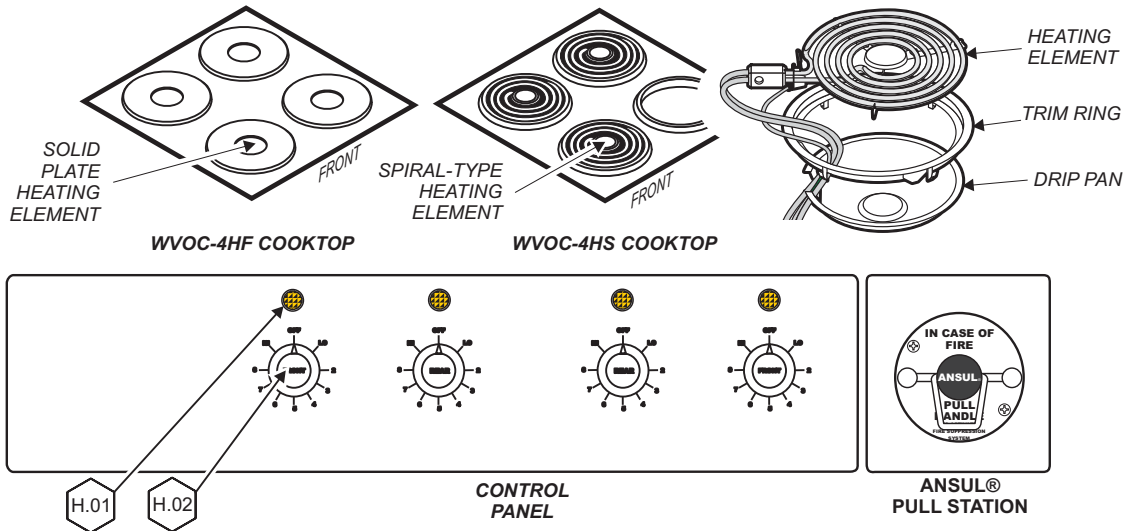

Fig. 3 Cooktop Section Controls & Indicator Lights

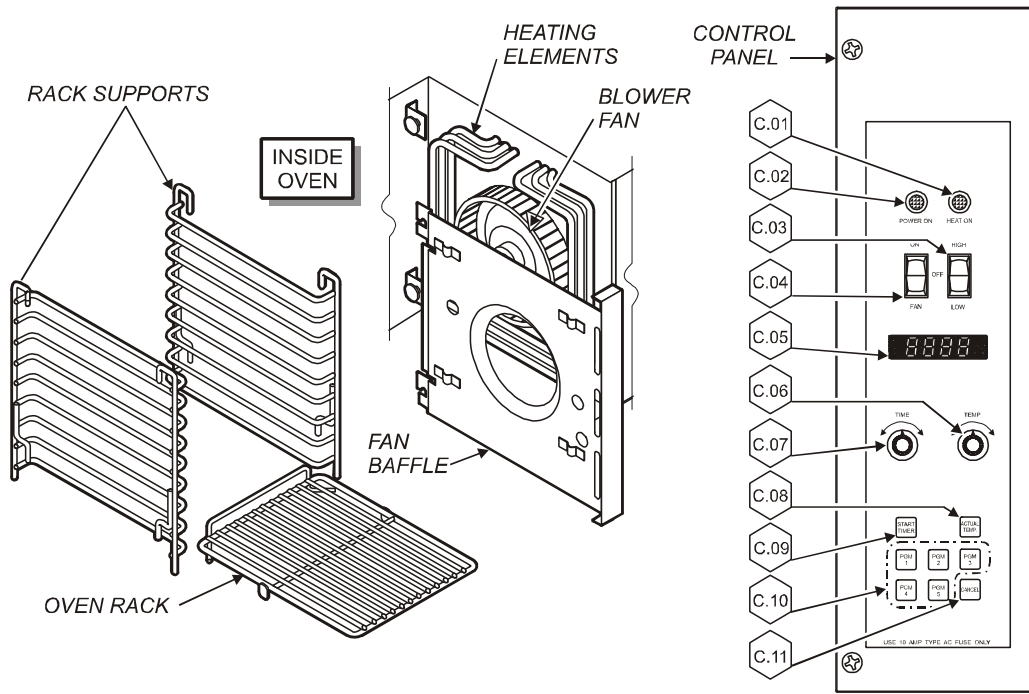

Fig. 4 Convection Oven Operating Features & Controls

## FEATURES & OPERATING CONTROLS (continued)

ITEM	DESCRIPTION	COMMENT
<b>VENTILATOR SECTION CONTROLS</b>		
V1	POWER SWITCH	
V2	POWER ON INDICATOR	<b>Energizes blower motor. If, after 10 seconds, proper conditions are met, cooktop is energized.</b>
V3	CHECK FILTERS ALARM INDICATOR	GREEN. Glows when POWER switch is ON.
V4*	REPLACE PREFILTER ALARM INDICATOR	AMBER. Glows if one or more filters are out of position. Check all filters and baffles for proper installation.
V5*	REPLACE FILTER PACK ALARM INDICATOR	AMBER. Glows when PREFILTER is approaching the end of its service life and must soon be replaced.
V6*	SERVICE REQUIRED ALARM INDICATOR	AMBER. Glows when FILTER PACK is approaching the end of its service life and must soon be replaced. RED. Glows when PREFILTER and/or FILTER PACK has reached the end of its service life and is too loaded to allow sufficient air flow. Filter <b>MUST</b> be replaced. Appliance is <b>SHUT DOWN</b> until expended filters are replaced.

\* See *PRECAUTIONS & GENERAL INFORMATION*, pages 6 & 7 for special procedures regarding prefilters and filter packs.

### COOKTOP SECTION CONTROLS

H.01	POWER ON INDICATOR	AMBER. Glows when associated temperature control is turned ON.
H.02	HOTPLATE CONTROL	Infinite switch control of temperature of one hotplate section.

### CONVECTION OVEN SECTION CONTROLS

C.01	POWER-OFF-FAN SWITCH	Switch to turn oven ON, OFF, or select FAN only.
C.02	FAN LOW-OFF-HIGH SWITCH	Switch to turn fan ON, and to select fan speed.
C.03	OVEN POWER INDICATOR	AMBER. Glows when oven is turned ON.
C.04	HEAT INDICATOR	AMBER. Glows when heating elements are energized.
C.05	DIGITAL DISPLAY	Displays time and temperature information. A. Time remaining in program (minute : second) B. Programmed temperature (°F)
C.06	OVEN TIME CONTROL	Adjust programmed cooking time.
C.07	OVEN TEMP CONTROL	Adjust programmed cooking temperature.
C.08	START TIMER KEY	Begin a timed cook cycle.
C.09	ACTUAL TEMP KEY	Press to display current oven temperature.
C.10	PGM KEYS	Press to select pre-programmed time/temperature.
C.11	CANCEL KEY	Press to cancel a program in progress.

HOTPLATE

CONVECTION OVEN

## PRECAUTIONS AND GENERAL INFORMATION



### WARNING: SHOCK HAZARD

All servicing requiring access to non-insulated electrical components must be performed by a factory authorized technician. DO NOT open any access panel which requires the use of tools. Failure to follow this warning can result in severe electrical shock.



### CAUTION: RISK OF DAMAGE

DO NOT connect or energize this appliance until all installation instructions are read and followed. Damage to the appliance will result if these instructions are not followed.

**NOTE:** Fire suppression system and all associated components must only be serviced by an authorized Ansul® Distributor. All setup, charging, repair and/or adjustment of the fire suppression system must be performed by an **Authorized Ansul® Distributor ONLY**.

**IMPORTANT:** If a remote pull station is installed, both rear casters (9) must be replaced with legs to deter moving the unit. **MOVING AN APPLIANCE WITH A REMOTE PULL STATION WILL DISCHARGE THE FIRE SUPPRESSION SYSTEM.**

This Ventless Cooking System™ is designed to help reduce odor emissions, but will not completely eliminate cooking odors. Air exchange at the installation site must comply with the requirements of the local jurisdictional authority. To ensure that odors do not build-up, recommended minimum air exchange is 300 - 400 cfm of outside air into *and out of* the area where the unit is used. Recommend use of wall fan and wall switch, to be supplied by user.

This appliance is intended for use in commercial establishments only.

This appliance is intended to prepare food for human consumption. No other use is recommended or authorized by the manufacturer or its agents.

Operators of this appliance must be familiar with the appliance use, limitations and associated restrictions. Operating instructions must be read and understood by all persons using or installing this appliance.

Cleanliness of this appliance is essential to good sanitation. Read and follow all included cleaning instructions and schedules to ensure the safety of the food product.

Disconnect this appliance from electrical power before performing any maintenance or servicing.

Do not splash or pour water on, in or over any exposed element, control, control panel or wiring.

DO NOT submerge pre-filter or filter pack in water.

The technical content of this manual, including any wiring diagrams, schematics, parts breakdown illustrations and/or adjustment procedures, is intended for use by qualified technical personnel.

Any procedure which requires the use of tools must be performed by a qualified technician.

This manual is considered to be a permanent part of the appliance. This manual and all supplied instructions, diagrams, schematics, parts breakdown illustrations, notices and labels must remain with the appliance if it is sold or moved to another location.

This appliance is made in the USA. Unless otherwise noted, this appliance has American sizes on all hardware.



## PRECAUTIONS AND GENERAL INFORMATION (continued)

### OPERATIONAL NOTES:

*REPLACE PREFILTER* and *REPLACE FILTER PACK* indicator lights provide a timely warning that a system shut-down is imminent.

The actual time between the indicator light coming on and the loss of cooking appliance power will depend upon the cooking conditions.

Anytime a dirty PRE-FILTER is replaced, the system airflow will increase. If the condition of the FILTER PACK is marginal, the *REPLACE FILTER PACK* light could then come on. If this happens, a fresh FILTER PACK must be installed within a reasonably short time.

Loss of airflow through the old filter pack will soon cause a system shut-down when the airflow falls below minimum vapor capture levels.

### **KEEP SPARE FILTER PACKS ON HAND.**

**IMPORTANT:** If you decide to “get the most” out of the old filter pack, and continue to use it until a system shut-down happens, it is advisable to have a fresh filter pack readily at hand, and have someone available who is capable of replacing it. Otherwise, you may experience an extended down time, with consequent associated loss of business.

**The manufacturer assumes no liability for loss of business due to a system shutdown caused by a dirty pre-filter and/or filter pack (i.e. red *SERVICE REQUIRED* light is on), when the user fails to have the proper replacement pre-filter and/or filter pack on hand.**

The Ventless Cooking System™ hood is designed as part of a **WELLS cooking appliance** only. No other use of this product is authorized by the manufacturer or its agents. Wells Mfg. assumes no liability for the use of this equipment with products by any other manufacturer's, or for use of this equipment with any Wells Manufacturing product other than in factory certified applications.

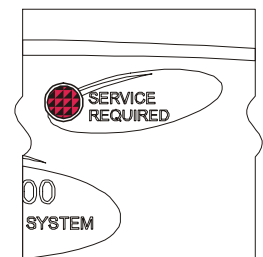
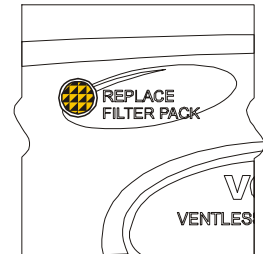
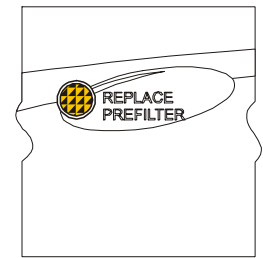

Fig. 5 Ventilator Warning Indicators

## AGENCY LISTING INFORMATION

This appliance conforms to NSF Standard 4 for sanitation only if installed in accordance with the supplied *Installation Instructions* And operated and maintained in accordance with the instructions in this manual.

This appliance is  listed under UL File E146882.



STD 4



E146882

## INSTALLATION

**NOTE:** DO NOT discard the carton or other packing materials until you have inspected the appliance for hidden damage and tested it for proper operation. Refer to *SHIPPING DAMAGE CLAIM PROCEDURE* on the inside front cover of this manual.



### **WARNING: RISK OF INJURY**

Installation procedures must be performed by a qualified technician with full knowledge of all applicable electrical codes. Failure can result in personal injury and property damage.



### **WARNING: FIRE HAZARD**

Avoid storing flammable or combustible materials near the appliance.

## UNPACKING & INSPECTION

Carefully remove the appliance from the carton. Remove all protective plastic film, packing materials and accessories from the Appliance before connecting electrical power or otherwise performing any installation procedure.

Carefully read all instructions in this manual and the *Installation Instruction Sheet* packed with the appliance before starting any installation.

Read and understand all labels and diagrams attached to the appliance.

Carefully account for all components and accessories before discarding packing materials. Store these components in or near the appliance for later use. These items must be installed before operating the appliance.

- 1 ea. FIRE SUPPRESSION AGENT (**ANSULEX® Low pH**, 1.5 GAL.)  
See *Material Safety Data Sheet*, page 28.
  - 1 ea. FIRE SUPPRESSION MEDIA TANK
  - 1 ea. FIRE SUPPRESSION TANK CHARGING CARTRIDGE
  - 1 ea. GREASE BAFFLE
  - 1 ea. FILTER PACK ASSEMBLY
  - 1 ea. PRE-FILTER HOLDER with PRE-FILTER
  - 1 ea. GREASE CUP
  - 1 ea. GREASE TROUGH
  - 2 ea. 6" SIDE SPACERS
  - 1 ea. LITERATURE PACKAGE
- Additionally:
- 1 ea. FAN BAFFLE
  - 2 ea. RACK SUPPORTS
  - 3 ea. CONVECTION OVEN RACKS

## SETUP

Setup the appliance only on a firm level surface. Non-combustible material is recommended.

Refer to the *Installation Instruction Sheet* for required clearances. Maintain required clearances between the appliance and adjacent combustible surfaces. Verify 6" left and right side clearances to combustible construction. This appliance requires a **minimum of 8 ft (96")** (floor to overhead) to allow for adequate exhaust.

**IMPORTANT:** Provided 6" side spacers (item 58) must be installed on the appliance.

Verify that the VENTILATOR HOOD ASSEMBLY is properly and securely assembled to the cooking appliance before beginning the installation procedure.

***If a remote manual pull station is to be installed, replace the rear casters with legs.***

Level the unit after it is in its final position. Using a spirit level, verify that the unit is level front-to-back and side-to-side.

**SERVICE TECHNICIAN INSTALLATION NOTES**

An Ansul® technician must charge and arm the fire suppression system before the ventilator blower will operate. See page 10.

Installation and start up must be performed by an Authorized Installation Company.

Installer must complete the *WARRANTY REGISTRATION* form, and record appliance installation particulars on the *CUSTOMER SERVICE DATA* form in this manual.

Certain codes require cooking equipment to be restrained with a RESTRAINT DEVICE. It is the RESPONSIBILITY OF THE INSTALLER to check with the AUTHORITY HAVING JURISDICTION, in order to ascertain the applicability of this requirement to THIS SPECIFIC EQUIPMENT INSTALLATION. Any restraint device must allow access to the back and sides of the unit to provide for servicing and maintenance, and must not interfere with the operation of the FIRE SUPPRESSION SYSTEM.

**ELECTRICAL INSTALLATION**

1. This appliance must be installed by a licensed electrician in accordance with all applicable codes and ordinances. Electrical connection terminal block and ground lug are accessible by removing the right side panel.
2. Refer to the nameplate on the right side of the appliance. Verify the ELECTRICAL SERVICE POWER. Voltage and phase must match the nameplate specifications, and available electrical service amperage must meet or exceed the specifications listed on page 1. Wiring must be no less than 4 AWG solid copper wire, rated for at least 90°C.

**NOTE:** Wire gauge, insulation type and temperature rating, as well as type, size and construction of conduit, must meet or exceed applicable specifications of local codes and of the National Electrical Code.

3. This appliance must be connected to a suitable building ground. The equipment ground connection is marked "  ".
4. The appliance is shipped from the factory wired for 3-phase electrical service. Refer to the *Wiring Diagram* included with this appliance, and verify that field wiring conforms to this diagram.

**IMPORTANT:** This appliance is not approved for 1Ø operation. Conversion of this appliance to single-phase operation will void the warranty.

**IMPORTANT!**

Verify that this VENTILATOR and food cooking equipment installation is in compliance with the specifications listed in this manual, with local code requirements, and in accordance with N.F.P.A 96 (*THE STANDARD FOR VENTILATION CONTROL AND FIRE PROTECTION OF COMMERCIAL COOKING OPERATIONS* - current edition).

THIS IS THE  
RESPONSIBILITY  
OF THE INSTALLER



**DANGER  
ELECTRIC  
SHOCK  
HAZARD**

ELECTRIC CONNECTIONS MUST BE MADE BY A LICENSED ELECTRICIAN. Electrical shock will cause death or serious injury.



**CAUTION:  
ELECTRIC  
SHOCK HAZARD**

The ground lug of this appliance must be connected to a suitable building ground. **NOTE:** This appliance requires a dedicated 60 Amp electrical branch circuit protection.

**IMPORTANT:**

Contact a licensed electrician to install and connect electrical power to the appliance.

**IMPORTANT:**

Damage due to being connected to the wrong voltage or phase is NOT covered by warranty.

## INSTALLATION (continued)

**DANGER**  
FIRE  
HAZARD



THE FIRE SUPPRESSION SYSTEM MUST BE CHARGED AND CERTIFIED BY AN AUTHORIZED **ANSUL®** DISTRIBUTOR. **NEVER** ATTEMPT TO MODIFY OR BYPASS THE FIRE SUPPRESSION SYSTEM. AN UNCONTROLLED FIRE CAN CAUSE SERIOUS INJURY, DEATH AND/OR PROPERTY LOSS.

**IMPORTANT:** The FIRE SUPPRESSION SYSTEM must be SET-UP and CHARGED by an authorized **Ansul®** distributor before the ventilator blower will operate.

**NOTE:** If the fire suppression system is discharged, a buzzer will sound continuously and the cooking appliance will remain inoperable until the fire suppression system is serviced. **Recharging and resetting must be performed by an authorized Ansul® distributor ONLY.**

Charging of the Ansul Fire Suppression system must be in accordance with *Ansul® Design, Installation, Recharge and Maintenance Manual*. (Ansul® #418087-05)

## FIRE SUPPRESSION SYSTEM INSTALLATION

1. Any REMOTE MANUAL PULL STATION must be installed by an authorized **ANSUL®** distributor in accordance with the AUTHORITY HAVING JURISDICTION.

**NOTE:** If a REMOTE MANUAL PULL STATION is installed, moving the unit for servicing will cause the **Ansul®** system to discharge. In this case, the unit must only be installed with four fixed legs (i.e. remove rear casters and replace with legs). Additional legs may be ordered through an Authorized Wells Service Agency. See page 25.

2. The FIRE SUPPRESSION SYSTEM is comprised of a pressurized cartridge & container of liquid fire suppressant, with associated plumbing and controls. It utilizes factory installed FUSIBLE LINKS for automatic actuation, and a factory installed MANUAL PULL STATION for manual actuation. Two NOZZLES are used to disperse the liquid fire suppression media.

3. When the fire suppression system activates, the fire suppression media is discharged, both the cooking appliance and the ventilator are de-energized, and a buzzer will sound continuously. The fire suppression media will form an emulsion designed to both smother and cool the fire.

**Call your Authorized Ansul® Distributor immediately for service.**

**NOTE:** See page 28 for the Material Safety Data Sheet for the fire suppression agent.

4. The MANUAL PULL STATION and any similar REMOTE MANUAL PULL STATION will activate the fire suppression system when the ring on the pull station is pulled horizontally.

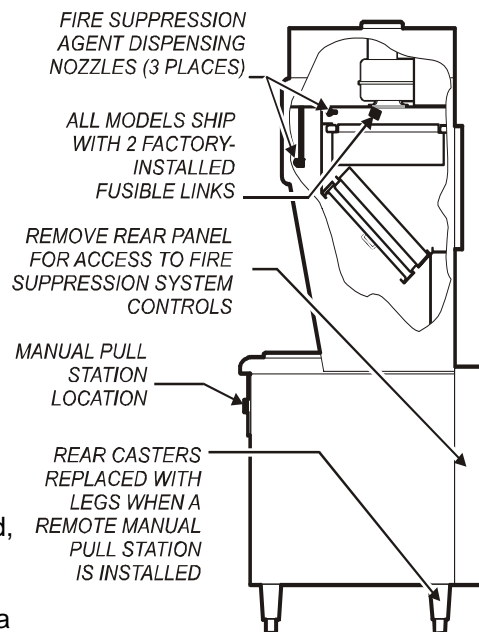

Fig. 6 Fire Suppression System

## FILTERS INSTALLATION

- FILTER PACK:** Ships installed in the hood. If the FILTER PACK is not in position, the *CHECK FILTERS* indicator will light. If the FILTER PACK becomes clogged, the *REPLACE FILTER PACK* indicator will glow.

To install the FILTER PACK: Position the filter pack with the charcoal portion UP. Slide the filter pack toward the rear of the unit until it contacts the guides on the back panel. Push the filter pack UP into the upper opening until it rests firmly against the filter pack seal. When up in position, holder clips can be snapped over wall ledge on each side. To remove FILTER PACK: Grasp both holder clips and pull INWARD until the clips clear the sidewall ledge. Then, pull the filter pack down and out.
- PRE-FILTER:** The PRE-FILTER ships in the FILTER FRAME. If the PRE-FILTER is not in position, or if the PRE-FILTER is not in the FILTER FRAME, the *CHECK FILTERS* indicator will light. If the PRE-FILTER becomes clogged, the *REPLACE PRE-FILTER* indicator will glow.

To install the PRE-FILTER: Pay attention to the air flow markings. The *AIR FLOW* arrow will point away from the installer. Slide the assembly up into the front opening, behind the upper filter rail. While pressing slightly against the bottom of the assembly, pull the FILTER HANDLE toward you so as to engage the FILTER HOOK over the lip of the top filter rail. Then lower and seat the assembly into the top indentation of the lower filter rail.
- GREASE BAFFLE:** If the GREASE BAFFLE is not in place, the *CHECK FILTERS* indicator will glow.

To install the GREASE BAFFLE: Slide the grease baffle up into the indentation of the upper filter rail, then lower and seat it into the bottom indentation of the lower filter rail. Pull toward you and downward to verify the GREASE BAFFLE is properly seated in the lower frame rail.

### NOTE:

The GREASE BAFFLE and FILTER PACK activate mechanical switches, and the PRE-FILTER activates a vacuum switch, to verify that the filter elements are in their proper positions. All filter elements must be properly installed or the cooktop will not be energized. Also, the *CHECK FILTERS* indicator will light.

### IMPORTANT:

**The filter hook prevents the PRE-FILTER from being drawn in during operation.** After installation, press against the top of the filter frame to verify proper engagement of the filter hook over the lip of the top filter rail.

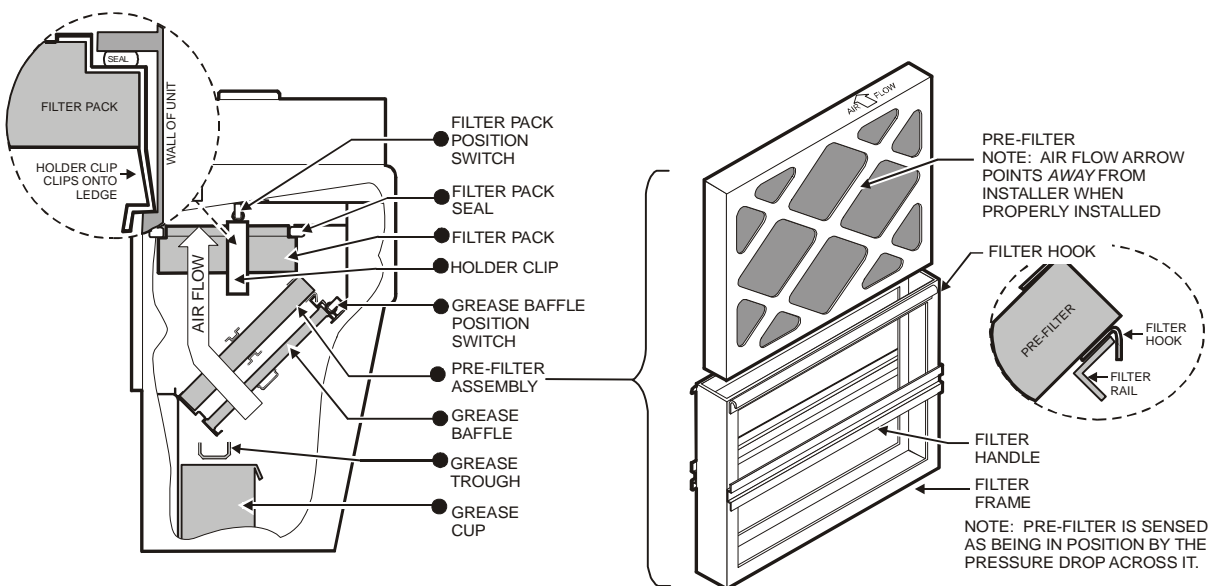

Fig. 7 Filter Installation

## INSTALLATION (continued)



**WARNING**  
**SLIP / FALL**  
**HAZARD**  
**SPILLED OIL**



**DO NOT OPERATE UNLESS  
THE GREASE CUP IS  
INSTALLED.**

Oil and moisture will drip onto the floor and falls may result. Death or serious injury may result from slipping and falling



**CAUTION:**  
**BURN HAZARD**



**DO NOT OPERATE UNLESS  
GREASE TROUGH  
IS INSTALLED.**

Moisture will drip into the hot cooking surface, causing splattering of hot liquids. Serious injury can result from contact with hot splatter.

## GREASE TROUGH AND GREASE CUP INSTALLATION

1. Install the GREASE TROUGH into the brackets below the grease baffle.
2. Install the GREASE CUP on the right side of the unit, directly below the grease trough.

## OVEN RACK INSTALLATION

1. Install fan baffle. Use care around the fan. The blades are sharp.
2. Install one rack support on the fan baffle, and one rack support on the left wall of the oven cavity.
3. Install racks as needed for the product being prepared.

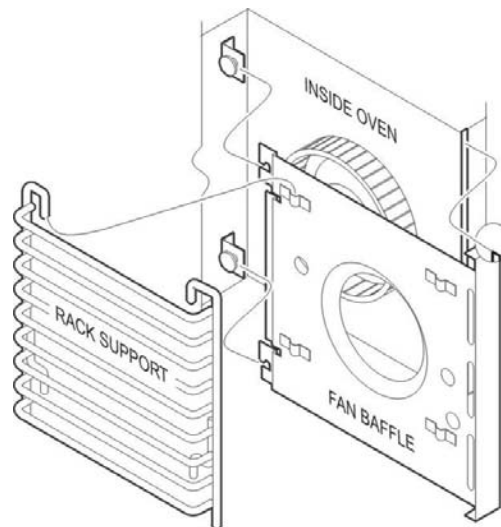

*Fig. 8 Oven Rack Installation*

**VENTILATOR OPERATION**

1. Press the VENTILATOR POWER switch to ON. The green VENTILATOR POWER light will glow and the blower fan will start. After a short time, if all filters are sensed as being in position and not clogged, the cooking appliance will be energized. The roll warmer is energized at all times.

During normal operation, the VENTILATOR POWER light will be the only light glowing on the upper control panel.

2. If the amber CHECK FILTER light glows, one or more filter elements is out of position. Check the GREASE BAFFLE, PRE-FILTER and FILTER PACK for proper installation in their respective positions. Grease baffle and filter pack position are sensed by mechanical switches. Pre-filter position is sensed by a vacuum switch.

3. When the amber REPLACE PRE-FILTER light glows, the pre-filter is nearing the end of its service life. Replace the disposable PRE-FILTER ELEMENT.

4. When the amber REPLACE FILTER PACK light illuminates, the HEPA / Charcoal filter pack is nearing the end of its service life. Replace the FILTER PACK.

**Note:** The REPLACE PRE-FILTER and REPLACE FILTER PACK lights are a warning that the indicated filter is near the end of its service life. The appliance will continue to operate for a period of time after the light glows to allow continued operation through a peak period. However, the indicated filters must be replaced within a reasonably short time period or they will clog and shut down electrical power to the cooking appliance. The ventilator blower will continue to run.

5. When the red SERVICE REQUIRED light glows, either the pre-filter or filter pack (or both) is clogged and can no longer pass sufficient air to allow further operation. The ventilator fan continues to run, but the cooking appliance is shut down until the underlying clogged filter situation has been corrected. This can occur when neither CHANGE...FILTER indicator light is lit, if both pre-filter and filter pack are marginal. Replacing both the pre-filter and the filter pack will remedy the situation.

**Note:** Replacing the pre-filter, even though not very dirty, will often extend the service life of the more expensive filter pack.

Reset the unit by turning the VENTILATOR POWER switch to OFF, then back ON.

6. A failure of incoming electrical power will cause a shut down of the unit. After power is restored, reset the unit by turning the VENTILATOR POWER switch to OFF, then back ON.

**NOTE:** Oven, griddle and hotplate will not operate unless the fire suppression system is charged, and the ventilator section is operating



**CAUTION:  
HOT SURFACE**

Exposed surfaces can be hot to the touch and may cause burns.

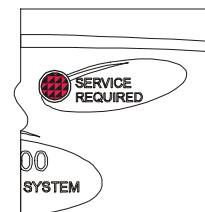
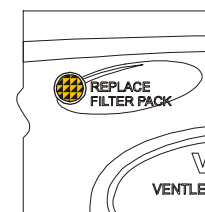
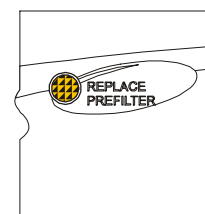
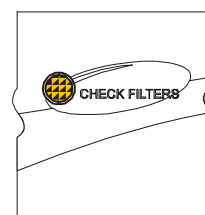
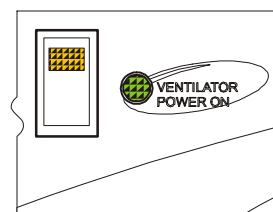

Fig. 9 Ventilator Indicator and Warning Lights

## OPERATION (continued)

### SUGGESTED COOKING TIMES

#### A. CONVECTION OVEN

PRODUCT	TEMP °F	TIME MINUTES	NUMBER OF RACKS
<b>BREAD PRODUCTS</b>			
Hamburger Roll	300	15	5
Bread (1 lb loaves)	325	34	3 (12 loaves)
Roll	300	16	5 (60 rolls)
Baking Soda Biscuit	400	7	3
For best baking results, use rack positions 2, 5 & 8 ( where rack position 1 is the top rack) Baking one pan: use rack 5; baking 2 pans: use racks 2 & 8.			
<b>PASTRIES</b>			
Sheet Cake (2½ lbs. per pan)	300	17	5
Frozen Fruit Pie (46oz.)	350	50	5 (10 pies)
Frozen Fruit Pie (26oz. - 8" dia.)	350	40	5 (15 pies)
Sugar Cookie	300	15	5
Danish Roll	350	12	5
Fruit Cake	275	75	3
Cake (1 lb.)	300	19	5 (10 cakes)
<b>OTHER</b>			
Melted Cheese Sandwich	400	8	5
Idaho Potato (120 potatoes)	450	40	5
Macaroni & Cheese	350	30	5

**NOTE:** "HIGH" fan speed provides the fastest cook time. "LOW" fan speed is used for foods which are sensitive to air currents, such as meringue pie.



**CONVECTION OVEN OPERATING INSTRUCTIONS**

**A. MANUAL COOK MODE**

1. Set the OVEN POWER SWITCH (C.01) to ON. The OVEN POWER ON INDICATOR (C.03) will glow when the switch is ON.
2. Rotate OVEN TEMPERATURE CONTROL knob (C.07) until the desired cooking temperature is displayed on the READOUT (C.05A). The oven will begin heating, and the temperature digits will flash, until the set temperature is reached.
3. Rotate OVEN TIME CONTROL knob (C.06) until the desired time is displayed on the READOUT. The digits and colon will flash, indicating that time has been set but the timer is not started.
4. Load product in the oven. Press START TIMER key (C.08). The timer digits count down and the colon (only) flashes during the timer period.
5. At the end of the timer period, an audible alarm will sound. Press CANCEL key (C.11) to silence the alarm.

**SUGGESTION:** For best baking results when making baking soda biscuits, use rack positions 2, 5 & 8 ( where rack position 1 is the top rack). When baking one pan: use rack 5 (center rack); when baking 2 pans: use racks 2 & 8; when baking three pans: use racks 2, 5 & 8.

**B. PROGRAM COOK MODE**

1. Five (5) programmable keys (C.10) are provided for presetting frequently used time / temperature combinations. To set the program:
  - a. Press and hold the appropriate PGM key.
  - b. While holding the PGM key, turn the TIME and TEMP knobs until the desired time and temperature is displayed on the readout.
  - c. Release the PGM key to store the displayed time and temp in memory.
2. The program for any PGM key can be recalled by momentarily pressing that PGM key.
3. To start a programmed cook cycle, press the appropriate PGM key and the START TIME key. Once the cook cycle has started, the TIME and TEMP knobs are locked out to prevent accidental re-programming.
4. The actual oven temperature may be recalled at any time by pressing the ACTUAL TEMP key (C.09).
5. At the end of the timer period, an audible alarm will sound. Press CANCEL key (C.11) to silence the alarm.



**CAUTION:  
HOT SURFACE**

Exposed surfaces can be hot to the touch and may cause burns.



**CAUTION:  
ELECTRIC SHOCK HAZARD**

DO NOT splash or pour water onto control panel or wiring.



**CAUTION:  
ELECTRIC SHOCK HAZARD**

DO NOT operate the unit if the keypad is torn or broken.

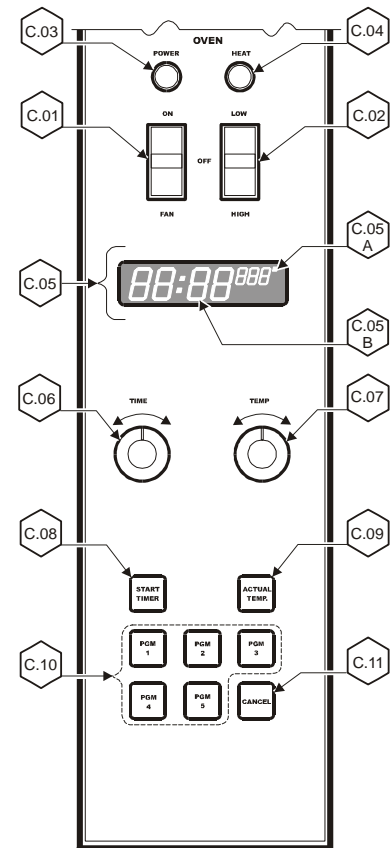

## OPERATION (continued)



### CAUTION: HOT SURFACE

Exposed surfaces can be hot to the touch and may cause burns.

---



### CAUTION: BURN HAZARD

Do not attempt to clean the oven until it has cooled to 150°F or less. See *CLEANING INSTRUCTIONS*, page 18.

---



### CAUTION: ELECTRIC SHOCK HAZARD

DO NOT splash or pour water onto control panel or wiring.

---

### IMPORTANT:

To extend the life of your appliance and internal components, allow the oven, and hotplates to cool to 200°F or less before turning the ventilator off.

### C. TEMPERATURE OFFSET MODE

1. A user preference offset mode is provided should the user feel the oven cooks too hot or too cold.
2. The OFFSET MODE can be used to offset the set / displayed temperature from the sensed temperature by as much as  $\pm 35^{\circ}\text{F}$ , in  $5^{\circ}\text{F}$  increments:
  - a. Rotate the TIME controller until the time digits on the display read "00:00".
  - b. Rotate the TEMP control until the temp digits display between  $400^{\circ}$  and  $500^{\circ}$ .
  - c. Press and hold the START TIMER key for five seconds.
  - d. Turn either the TIME or TEMP control until the desired offset is displayed.
  - e. Press the ACTUAL TEMP key to exit.

**HOTPLATE OPERATING INSTRUCTIONS**

**A. COOKING WITH YOUR HOTPLATE**

1. Each element is individually controlled by a TEMPERATURE CONTROL (H.01 and H.03). These are *infinite switch* controls which control based on electrical current draw, not the actual temperature of the hotplate surface.
2. Settings are *OFF* to *HIGH*.
3. The associated indicator will glow when the switch is in any position other than *OFF*.
4. When set to *HIGH*, the hotplate element can reach maximum temperature in approximately 10 minutes.
5. Once liquid begins to boil, reduce the setting to minimize power consumption and increase the useful life of the elements.
6. Use cooking pans which fully cover the elements for maximum efficiency. Maximum recommended pot diameter is 10 inches.

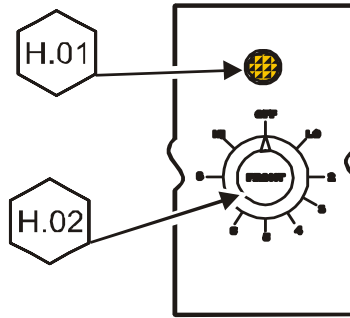

**CAUTION:  
HOT SURFACE**

Exposed surfaces can be hot to the touch and may cause burns.



**CAUTION:  
ELECTRIC  
SHOCK HAZARD**

DO NOT splash or pour water onto control panel or wiring.



**CAUTION:  
ELECTRIC  
SHOCK HAZARD**

Use extreme caution when using double broiler-type pans: DO NOT over fill the lower pan with water, which can cause an overflow. Any moisture splashed onto the hotplate top can leak into the lower areas of the oven causing a potential shock hazard and causing severe damage to the electronic controller.

**NOTE:** Damage caused by moisture leaking into the electronic controller is NOT covered by warranty.

**IMPORTANT:**

The dial markings are an INDICATION of temperature only. The temperature of the food product depends on many factors, including the size, shape and material of the food container, and the quantity and consistency of the food product.

## CLEANING INSTRUCTIONS



### CAUTION: CUT HAZARD

Use due care when cleaning near fan. Blades are sharp.



### CAUTION: ELECTRIC SHOCK HAZARD

DO NOT splash or pour water onto control panel or wiring.



### CAUTION: HEAT AND SMOKE HAZARD

Keep the ventilator fan running during any "hot surface" cleaning operation to avoid a build-up of heat and/ or smoke.

### IMPORTANT: Avoid Fire Suppression System discharge!

Keep the ventilator fan running during any "hot surface" cleaning operation to avoid melting a fusible link and causing a discharge of the fire suppression media.

### IMPORTANT:

Always rub / wipe in the direction of the polish lines or grain of the metal.

## CONVECTION OVEN CLEANING INSTRUCTIONS

**PRECAUTIONS** Turn oven power switch to *FAN*  
Allow oven to cool

**FREQUENCY** As Noted

**TOOLS** Mild Detergent, Soft Cloth or Sponge  
Plastic Scouring Pad  
Spray Bottle  
Commercial Oven Cleaner/Degreaser

### DAILY

1. Turn oven power switch to *FAN*; remove racks and take to back sink.
2. Let oven cool to 200°F. If oven is cooler than 200°F, raise temperature to no more than 200°F.
3. Mix oven cleaner/degreaser per manufacturer's directions. Spray oven cleaner/degreaser solution onto soiled surfaces; then, close oven door and let stand for 5 min.
4. Open door slowly to allow steam to escape and allow oven to cool completely.
5. Wipe oven surfaces with a soft cloth, rinse cloth as necessary.
6. Re-spray any remaining soiled areas and scrub with a plastic scouring pad.
7. Rinse all surfaces with a clean soft cloth dampened with clean water.
8. Wash, rinse, and sanitize oven racks and replace in oven.
9. Wipe exterior surfaces with a clean cloth dampened with clean water and a non-abrasive cleanser. Rinse by wiping with a clean cloth dampened with clean water.

### HEAVY SOIL RECOVERY—As Needed

1. Turn oven power switch to *FAN*; remove racks and take to back sink.
2. Let oven cool to 200°F. If oven is cooler than 200°F, raise temperature to no more than 200°F.
3. Spray Oven Cleaner/Degreaser full strength onto soiled surfaces; then, close oven door and let stand for 5 min.
4. Open door slowly to allow steam to escape and allow oven to cool completely.
5. Wipe oven surfaces with a soft cloth, rinse cloth as necessary.
6. Re-spray any remaining soiled areas and scrub with a plastic scouring pad.
7. Rinse all surfaces with a clean soft cloth dampened with clean water.
8. Wash, rinse, and sanitize oven racks and replace in oven.

## CLEANING INSTRUCTIONS (continued)

### HOTPLATE CLEANING INSTRUCTIONS

PRECAUTIONS	Turn oven controls to <i>OFF</i> Allow hotplates to cool
FREQUENCY	Daily
TOOLS	Mild Detergent, Soft Cloth or Sponge Non-abrasive Cleaner, Plastic Scouring Pad

1. Turn both controls to *OFF*. Allow both hotplate elements to cool.
2. Wipe the entire hotplate top panel using a clean cloth or sponge, dampened with hot water and a mild detergent. For burned-on foods or sauce spillage, use a non-abrasive cleanser applied with a plastic scouring pad.
3. Rinse hotplates and top panel with a soft cloth dampened with clean water.



#### CAUTION: BURN HAZARD

Turn off both hotplates and allow to cool before cleaning



#### CAUTION: ELECTRIC SHOCK HAZARD

DO NOT splash or pour water onto warmer, control panel or wiring.



#### CAUTION: HEAT AND SMOKE HAZARD

Keep the ventilator fan running during any "hot surface" cleaning operation to avoid a build-up of heat and/or smoke.

#### IMPORTANT: Avoid Fire Suppression System discharge!

Keep the ventilator fan running during any "hot surface" cleaning operation to avoid melting a fusible link and causing a discharge of the fire suppression media.

#### IMPORTANT:

This appliance is not jet stream approved. Do not direct water jet or steam jet at this appliance, or at any control panel or wiring. Do not splash or pour water on, in or over any controls, control panel or wiring.

#### IMPORTANT:

Always wipe or rub in the direction of the polish lines or grain of the metal.

## CLEANING INSTRUCTIONS (continued)



### CAUTION: ELECTRIC SHOCK HAZARD

Disconnect appliance from electric power before cleaning.



### CAUTION: HOT SURFACE

Exposed surfaces can be hot to the touch and may cause burns. Allow appliance to cool before cleaning.

### IMPORTANT:

Never allow PRE-FILTER or FILTER PACK to get wet. DO NOT wash either of these two filters. Washing these filters will ruin them and cause the appliance to shut-down.

### IMPORTANT:

DO NOT spill or pour water into controls, control panel, wiring or coil-type hotplate elements. Damage to internal components will occur. Damage to internal components from water damage is **not** covered by warranty.

### IMPORTANT:

DO NOT use steel wool or metal implements to clean drawers or cabinet surfaces.

## VENTILATOR SECTION CLEANING INSTRUCTIONS

### PREPARATION

Disconnect appliance from electric power  
Allow to cool before cleaning

**FREQUENCY** Weekly

### TOOLS

Warm water and a mild detergent  
Soft clean cloth or sponge  
Bristle brush  
Container for disposal of grease

### CLEANING

Disconnect appliance from electric power  
Allow to cool before cleaning

Remove the grease baffle, pre-filter assembly, grease trough and grease cup. Empty the grease trough and grease cup.

Remove the pre-filter from the filter frame. Wash and rinse the filter frame ONLY.

Wash and rinse the grease baffle, grease trough and grease cup in a sink or dishwasher using mild detergent and warm water. Allow to air dry.

Reinsert the pre-filter into the filter frame. Reinstall the pre-filter, grease baffle, grease trough and grease cup.

Procedure is complete

## TROUBLESHOOTING SUGGESTIONS

### A. NO PART OF THE APPLIANCE WILL HEAT

1. Verify that appropriate cooking controls are *ON*.
2. Check electrical supply. Make sure service breaker is *ON*.
3. Make sure all filters are properly installed, and that no filter warning lights are lit.
4. Possible improper service wiring: Have a licensed electrician verify that all three legs of the 3 $\phi$  service are properly connected (i.e. Leg 1 to L1, Leg 2 to L2, Leg 3 to L3), and that all three legs are of the proper voltage and phase.
5. Ansul® Fire Suppression System not charged.

### B. HOTPLATE WILL NOT HEAT

1. Verify that associated temperature control is set to the desired temperature.
2. Possible internal component damage: Have unit serviced by an Authorized Wells Service Agency.

### C. CONVECTION OVEN WILL NOT HEAT See Error Codes diagram at right

1. Verify that the oven switch is *ON* and that the temperature control is set to the desired temperature.
2. Verify that the door is closed.
3. Hi-Limit control may have tripped: Allow unit to cool; Hi-Limit will reset automatically.
4. Blown fuse(s) (item 40): Correct cause of over-current and replace fuses with fuses having the same configuration and ratings.
5. Possible internal component damage: Have unit serviced by an Authorized Wells Service Agency.

### D. CONVECTION OVEN FAN WILL NOT RUN

1. Verify that the oven switch is set to *ON* or *FAN*.
2. Verify that the fan switch is set to either *HIGH* or *LOW*.
3. Hi-Limit control may have tripped: Allow unit to cool; Hi-Limit will reset automatically.
4. Blown fuse(s): Correct cause of over-current and replace fuses with fuses having the same configuration and ratings.
5. Possible internal component damage: Have unit serviced by an Authorized Wells Service Agency.



### CAUTION: ELECTRIC SHOCK HAZARD

Removal of any cabinet panel will result in exposed electrical circuits. Any procedure requiring the removal of any cabinet panel must be performed by a qualified technician only.

### CONVECTION OVEN CONTROLLER ERROR CODES

- F1** Relay closed or relay ohms low when not cooking
- F2** Actual temperature 60°F ( $\pm 35^\circ\text{F}$ ) greater than T-SET MAX
- F3** Open temperature sensor
- F4** Shorted temperature sensor
- F5** Relay open or relay ohms high when cooking
- F6** No 60 Hz (Cycles per second other than 60 Hz detected)

Have unit serviced by an Authorized Wells Service Agency.

**NOTE:** Other than the ventilator filters, there are no user serviceable components in the appliance. In all cases of damage or component malfunction, contact your Authorized Wells Service Agency for repairs.

## MAINTENANCE INSTRUCTIONS



### CAUTION: RISK OF INJURY

Disconnect appliance from electrical power before performing any of these procedures.

## FAN CLEANING

**PRECAUTIONS:** Disconnect power at the circuit breaker.  
Allow the oven to cool.

**FREQUENCY:** Monthly, at a Minimum; or, As Needed

**TOOLS:** Moist Cloth or Sponges  
Bristle Brush



### CAUTION: CUT HAZARD

Use due care when cleaning fan. Blades are sharp.

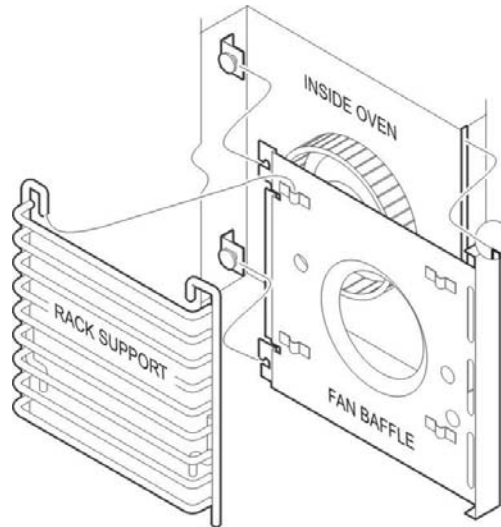

1. Disconnect power at the circuit breaker. Allow the oven to cool.
2. Remove RACKS by pulling toward the front. Lift to clear the stop pin. Remove left and right RACK SUPPORTS by lifting.
3. Remove BAFFLE by lifting the rear slightly and pulling straight out.
4. Brush fan wheel and wipe it with a moist cloth. Sponge out all loose particles.
5. Reassemble, paying particular attention that the lip on the right side of the fan baffle is fully seated in the slot in the edge of the oven cavity.



## MAINTENANCE INSTRUCTIONS (continued)

### HINGE ADJUSTMENT

**PRECAUTIONS:** None

**FREQUENCY:** Monthly, at a Minimum; or, As Needed

**TOOLS:** Phillips (+) Screwdriver  
7/16" Nut Driver  
7/8" and 1-1/8" Wrenches



**CAUTION:  
BURN HAZARD**

Allow appliance to cool completely before adjusting.

### THE FOLLOWING PROCEDURE IS TO BE PERFORMED BY QUALIFIED PERSONNEL ONLY

1. Remove bottom panel to access pivot.

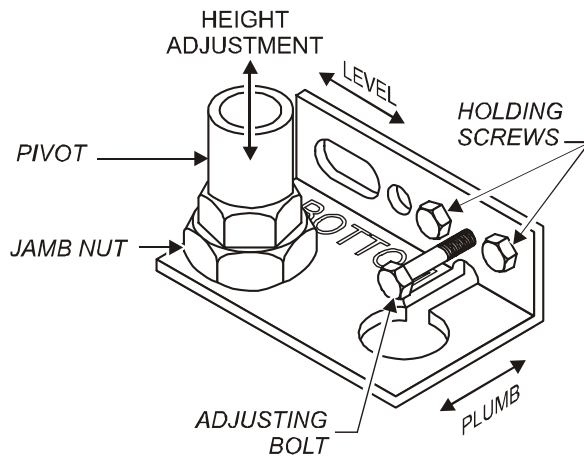

2. Gap between top of door and frame, and between bottom of door and frame must be approximately equal

Adjust height of door by loosening jamb nut, then turning pivot on its screw mounting. Clockwise lowers the door height. Re-tighten jamb nut.

3. Gap between left side of door and frame must be the same from top to bottom

Adjust door for plumb by loosening holding screws. Turn adjusting bolt to increase or decrease gap at bottom. Clockwise increases gap. Re-tighten holding screws.

4. Gap between top of door and frame must be the same from side to side

Adjust door for level by loosening holding screws, then raising or lowering latch-end of door until it is level. Re-tighten holding screws.

5. Reinstall bottom panel.

Procedure is complete

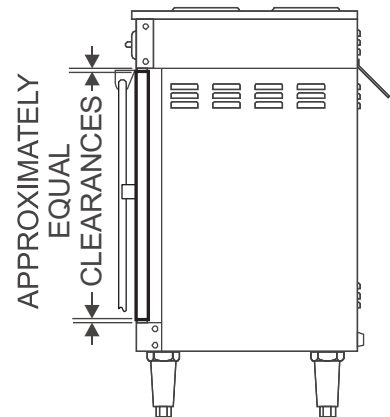
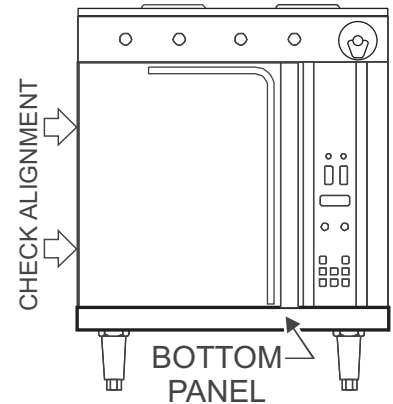

*Hinge Adjustment*

## MAINTENANCE INSTRUCTIONS (continued)



### CAUTION: Hot Surface

Exposed surfaces can be hot to the touch and may cause burns.

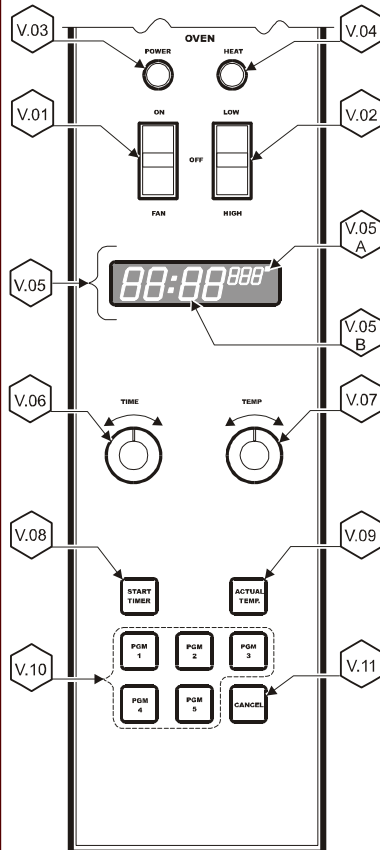

### D. TEMPERATURE CALIBRATION

TOOLS: Digital Pyrometer with Oven Probe, Protective Gloves

1. With the oven empty, clamp the thermocouple sensor in the center of the middle rack:
  - a. Pass the thermocouple sensor wires through the corner of the door gasket and close the door.
  - b. Plug the sensor into the Pyrometer.
2. Turn the OVEN POWER (V.01) switch to *ON*. Turn the FAN switch (V.02) to *HI*.
  - a. Rotate the TIME control (V.06) until the time digits (V.05B) on the display read "60:00".
  - b. Rotate the TEMP control (V.07) until the temp digits (V.05A) display 375°.
  - c. Press the START TIMER key (V.08).
3. Allow the oven to heat for 45 minutes. If, after 45 minutes, the temperature display reads between 370° and 380°, the calibration is satisfactory. Otherwise:
  - a. Rotate the TIME controller until the time digits (V.05B) on the display read "00:00".
  - b. Rotate the TEMP control until the temp digits (V.05A) display between 400° and 500°.
  - c. Press and hold the START TIMER (V.08) key for five seconds.
  - d. Turn either the TIME or TEMP control until the desired offset is displayed.
  - e. Press the ACTUAL TEMP (V.09) key to exit. Procedure is complete.

## MAINTENANCE SCHEDULES

### 1. 6-MONTH MAINTENANCE (MUST BE PERFORMED BY AN AUTHORIZED ANSUL® DISTRIBUTOR ONLY):

- a. Inspect and test total operation including FIRE DAMPER and all SAFETY INTERLOCKS.
- b. All FIRE SUPPRESSION SYSTEM actuation components including MANUAL PULL STATION and any REMOTE MANUAL PULL STATION must be inspected for proper operation in accordance with the maintenance schedule published in *ANSUL® R-102 SYSTEM DESIGN, INSTALLATION, RECHARGE AND MAINTENANCE MANUAL* (Ansul® #418087-05).
- c. The FIRE SUPPRESSION SYSTEM FUSIBLE LINKS must be inspected. NOZZLES and MANUAL PULL STATION must be cleaned in accordance with *ANSUL® R-102 SYSTEM DESIGN, INSTALLATION, RECHARGE AND MAINTENANCE MANUAL* (Ansul® #418087-05).
- d. The FIRE SUPPRESSION AGENT TANK, PIPING and FLEXIBLE TUBING must be INSPECTED.

### 2. 12-YEAR MAINTENANCE: (MUST BE PERFORMED BY AN AUTHORIZED ANSUL® DISTRIBUTOR ONLY):

- a. The FIRE SUPPRESSION AGENT TANK and ¼" FLEX HOSE must be HYDROSTATICALLY TESTED, and the FIRE EXTINGUISHING AGENT must be REPLACED in accordance with the maintenance schedule published in *ANSUL® R-102 SYSTEM (STANDARD UL 300 LISTED)*.
- b. The FUSIBLE LINKS in plenum and damper must be REPLACED. This maintenance to be performed by qualified **Ansul®** service personnel only.

USE AND MAINTENANCE SHALL BE IN ACCORDANCE WITH THE *STANDARD FOR VENTILATION CONTROL AND FIRE PROTECTION OF COMMERCIAL COOKING OPERATIONS*, N.F.P.A. 17A & N.F.P.A. 96 (current editions).



**DANGER  
FIRE  
HAZARD**

FAILURE TO PROPERLY CLEAN AND MAINTAIN THIS EQUIPMENT CAN CAUSE A FIRE. AN UNCONTROLLED FIRE CAN CAUSE SERIOUS INJURY, DEATH AND/OR PROPERTY LOSS.

NOTE: A signed and dated VENTILATOR HOOD MAINTENANCE LOG must be maintained on the premises, and shall be available for inspection by the authority having jurisdiction. See pages 26 & 27.

**IMPORTANT: Parts used for the Ansul® fire suppression system are not serviceable by the owner / operator.** Procedures for servicing fire suppression equipment are described in: *ANSUL® R-102 SYSTEM DESIGN, INSTALLATION, RECHARGE AND MAINTENANCE MANUAL* (Ansul® #418087-05).

Inspection shall be conducted on a monthly basis in accordance with the manufacturer's Operation Manual. At a minimum, this inspection shall include verification of the following:

**WELLS BLOOMFIELD, LLC**  
**VENTILATOR HOOD OWNERS MONTHLY INSPECTION LOG**

<b>OPERATION</b>	<b>AGENT / DATE</b>												
Extinguishing system components: In proper place and (visually) in good order													
Manual pull station actuators for fire suppression system are unobstructed													
The maintenance log is in place and up to date													
No obvious physical damage or condition exists that might prevent operation of the fire suppression system													
The nozzle blow-off caps are in place and in good condition													
The hood, duct and protected cooking appliance have not been replaced, modified or relocated													
Clean plenum GREASE BAFFLE and BLOWER (max. interval: 3 months)													
Change PRE-FILTER and FILTER PACK (as required)													

This MAINTENANCE LOG is to be performed and completed by a trained technician who has completed the instruction necessary to perform the maintenance and recharge service.

**WELLS BLOOMFIELD, LLC**  
**VENTILATOR HOOD MAINTENANCE LOG**

<b>OPERATION</b>		<b>AGENT / DATE</b>											
Clean and inspect discharge nozzle in plenum BEFORE filters Max. interval: 6 months													
Clean and inspect discharge nozzle in plenum AFTER filters Max. interval: 6 months													
Inspect fire suppression fuse links, all releasing devices for actuation, fire suppressant tank liquid level Max interval: 6 months (discharge of fire suppressant not a part of this test)													
Inspect fire suppression hoses, plumbing and tank for obstructions and any conditions such as, but not limited to, corrosion and pitting. Max. interval: 6 months													
Inspect and test all filter interlocks Max. interval: 6 months													
Replace two (2) fire suppression links in plenum: each link is rated @ 212°F	Log TEMP												
	Log Mfg DATE Stamp												
Max interval: 12 months	Log TEMP												
	Log Mfg DATE Stamp												
Replace fire damper fusible link: rated @ 280°F	Log TEMP												
	Log Mfg DATE Stamp												
Max interval: 12 months	Log TEMP												
	Log Mfg DATE Stamp												

**THIS MAINTENANCE LOG MUST BE KEPT IN A PROTECTIVE COVER PERMANENTLY ATTACHED TO THE APPLIANCE**  
 Log all repairs and recommendations on reverse side. Any repairs, other than replacement of factory authorized parts, to the fire suppression plumbing system must be subject to hydrostatic pressure testing.

ANSULEX Low pH  
QUICK IDENTIFIER (In Plant Common Name)

Manufacturer's Name:	<b>ANSUL INCORPORATED</b>	Emergency Telephone No.:	<b>CHEMTREC (800) 424-9300 or (703) 527-3887</b>
Address:	One Stanton Street, Marinette, WI 54143-2542	Other Information Calls:	(715) 735-7411
Prepared By:	Safety and Health Department	Date Prepared:	February 1, 1999

**SECTION 1 - IDENTITY**

Common Name (Used on Label): (Trade Name and Synonyms)	ANSULEX Low pH Liquid Fire Suppressant	CAS No.:	N/A
Chemical Name:	N/A This is a Mixture	Chemical Family:	Mixture
Formula:	N/A		

**SECTION 2 - INGREDIENTS**

PART A - HAZARDOUS INGREDIENTS				
Principal Hazardous Component(s) (chemical and common name(s)):	Wt. %	CAS No.	ACGIH TLV	Acute Toxicity Data
None	N/A	N/A	N/A	N/A
PART B - OTHER INGREDIENTS				
Other Component(s) (chemical and common name(s)):	Wt. %	CAS No.	ACGIH TLV	Acute Toxicity Data
Proprietary Mixture of Organic and Inorganic Salts	48.0 - 50.0	N/A	N/E	NDA
Phosphoric Acid	0.2	7664-38-2	N/E	NDA
EDTA	0.65	64-02-8	N/E	NDA
Yellow-Green Fluorescent Dye	0.011	518-47-8	N/E	Oral LD <sub>50</sub> (rat) 6800 mg/kg
Water	Approx. 50.0	7732-18-5	N/E	NDA

**SECTION 3 - PHYSICAL AND CHEMICAL CHARACTERISTICS (Fire and Explosion Data)**

Boiling Point:	113°C	Specific Gravity (H <sub>2</sub> O=1):	1.33	Vapor Pressure (mm Hg):	Not Determined
Percent Volatile by Volume (%):	Approx. 50.0	Vapor Density: (Air = 1):	1.03	Evaporation Rate: (Butyl Acetate=1):	Approx. 0.005
Solubility in Water:	100%	Reactivity in Water:	Mild exothermic reaction		
Appearance and Odor:	Fluorescent Yellow Colored Liquid, Mild Odor				
Flash Point:	None to boiling	Flammable Limits in Air % by Volume:	N/A	Extinguisher Media:	N/A
Auto-Ignition Temperature:	N/A				
Special Fire Fighting Procedures:	NONE - THIS IS AN EXTINGUISHING AGENT				
Unusual Fire and Explosion Hazards:	None				

**SECTION 4 - PHYSICAL HAZARDS**

Stability:	Unstable <input type="checkbox"/> Stable <input checked="" type="checkbox"/>	Conditions to Avoid:	N/A
Incompatibility (Materials to Avoid):	Reactive Metals, ClF <sub>3</sub> , electrically energized equipment, any material reactive with water.		
Hazardous Decomposition Products:	Not established, acrid fumes.		
Hazardous Polymerization:	May Occur <input type="checkbox"/> Will Not Occur <input checked="" type="checkbox"/>	Conditions to Avoid:	N/A

M506 p/n 304964 OpManual WVOC-4 Series Ventless Hotplate Cooktop Convection Oven

**SECTION 5 - HEALTH HAZARDS**

ANSULEX Low pH (continued)

Threshold Limit Value:	None Established		
Routes of Entry: Eye Contact:	Irritant		
Skin Contact:	Irritant		
Inhalation:	Not an expected route of entry. Can be irritating to mucous membranes.		
Ingestion:	Irritating to mucous membranes. Acute Oral LD <sub>50</sub> (Sprague-Dawley rats) 825.5mg/kg.		
Signs and Symptoms:	Acute Exposure: Material irritates skin, eyes, and mucous membranes. Chronic Exposure: None known.		
Medical Conditions Generally Aggravated by Exposure:	None known.		
Chemical Listed as Carcinogen or Potential:	National Toxicology Program: Yes <input type="checkbox"/> No <input checked="" type="checkbox"/>	I.A.R.C Monographs: Yes <input type="checkbox"/> No <input checked="" type="checkbox"/>	OSHA Yes <input type="checkbox"/> No <input checked="" type="checkbox"/>

**SECTION 6 - EMERGENCY AND FIRST AID PROCEDURES**

Eye Contact:	Flush and irrigate with water for 15 minutes while holding eyelids open. If irritation persists, seek medical attention.
Skin Contact:	Wash thoroughly with soap and water. If irritation persists, seek medical attention.
Inhalation:	Fresh air if symptoms occur. If irritation persists, seek medical attention.
Ingestion:	Dilute by drinking large quantities of water.

**SECTION 7 - SPECIAL PROTECTION INFORMATION**

Respiratory Protection (Specify Type):	N/A		
Ventilation:	Local Exhaust: N/A	Mechanical (General):	N/A
Protective Gloves:	Rubber gloves for spill/leak	Eye Protection:	Chemical goggles recommended during spill/leak procedures.
Other Protective Clothing or Equipment:	Eye wash and safety showers are good safety practice.		

**SECTION 8 - SPECIAL PRECAUTIONS AND SPILL/LEAK PROCEDURES**

Precautions to be taken in Handling and Storage:	Store in original container. Keep tightly closed. Keep separate from acid.
Other Precautions:	See incompatibility information in Section 4.
Steps to be taken in Case Material is Released or Spilled:	Stop leaks. Contain spills. Remove as much as possible. Place in closed container for proper disposal Wash spill area with large amounts of water to remove traces and neutralize.
Waste Disposal Methods:	Dispose of in compliance with local, state and federal regulations.

**HAZARDOUS MATERIAL IDENTIFICATION SYSTEM**

<i>HAZARD INDEX</i>	
4 SEVERE HAZARD	0 HEALTH
3 SERIOUS HAZARD	
2 MODERATE HAZARD	0 FLAMMABILITY
1 SLIGHT HAZARD	
0 MINIMAL HAZARD	0 REACTIVITY

N/A = Not Applicable      NDA = No Data Available      N/E = Not Established  
ANSUL and ANSULEX are registered trademarks.

Internet Address: <http://www.ansul.com>

ANSUL INCORPORATED, ONE STANTON STREET, MARINETTE, WI 54143-2542

Form No. F-90160-6

©1999 Ansul Incorporated

M/506 p/n 304964 OpManual WVOC-4 Series Ventless Hotplate Cooktop Convection Oven

**NOTES**



**DESCRIPTION**

**SERVICE PART NO.**

OVEN RACK Replacement	21376
PRE-FILTER	22618
PRE-FILTER CAGE	22683
FILTER PACK (HEPA + CHARCOAL)	22619
GREASE BAFFLE	22684
GREASE CUP	22626
LEG KIT	22829
CASTER KIT	22830
DRIP TRAY, 8" (Spiral Hotplate)	21705
SCRAPER, CLEANING (Ceramic Hotplate)	22445
ELEMENT SUPPORT (Spiral Hotplate)	500039
CLEANING CREME, CERAMIC HOTPLATE	501124

WELLS BULLETIN (ANSUL® PARTS LIST) 303331

**NOTE:** Ansul® Manual 418087-05 and Wells Bulletin 303331 are intended for use by authorized **Ansul®** service personnel only. Ansul® Manual 418087-05 must be obtained through your authorized Ansul® distributor.

**IMPORTANT: Use only factory authorized service parts and replacement filters.**

For factory authorized service, or to order factory authorized replacement parts, contact your Wells authorized service agency, or call:

**Wells Bloomfield, LLC**  
 2 Erik Circle  
 P. O. Box 280  
 Verdi, NV 89439

Service Parts Dept.  
 phone: (775) 689-5707  
 fax: (775) 689-5976

Service Parts Department can supply you with the name and telephone number of the **WELLS AUTHORIZED SERVICE AGENCY** nearest you.

**CUSTOMER SERVICE DATA**

please have this information available if calling for service

RESTAURANT \_\_\_\_\_ LOCATION \_\_\_\_\_  
 INSTALLATION DATE \_\_\_\_\_ TECHNICIAN \_\_\_\_\_  
 SERVICE COMPANY \_\_\_\_\_  
 ADDRESS \_\_\_\_\_ STATE \_\_\_\_\_ ZIP \_\_\_\_\_  
 TELEPHONE NUMBER (\_\_\_\_) \_\_\_\_\_ - \_\_\_\_\_

EQUIPMENT MODEL NO. \_\_\_\_\_  
 EQUIPMENT SERIAL NO. \_\_\_\_\_  
 VOLTAGE: (check one)  208  240



Wells Bloomfield proudly supports CFESA  
Commercial Food Equipment Service Association

**SERVICE TRAINING - QUALITY SERVICE**



**CUSTOMER SATISFACTION**



**WELLS BLOOMFIELD, LLC**  
2 ERIK CIRCLE, P. O. Box 280 Verdi, NV 89439  
telephone: 775-689-5703  
fax: 775-689-5976  
[www.wellsbloomfield.com](http://www.wellsbloomfield.com)

PRINTED IN UNITED STATES OF AMERICA