

PRO-FORM

CROSSWALK 395

Model No. 831.24833.0

Serial No. _____

Write the serial number in the space above for reference.

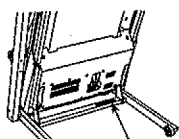

Serial Number
Decal

- Assembly
- Operation
- Maintenance
- Part List and Drawing

Sears, Roebuck and Co.
Hoffman Estates, IL 60179

CAUTION

Read all precautions and instructions in this manual before using this equipment. Keep this manual for future reference.

TREADMILL EXERCISER User's Manual

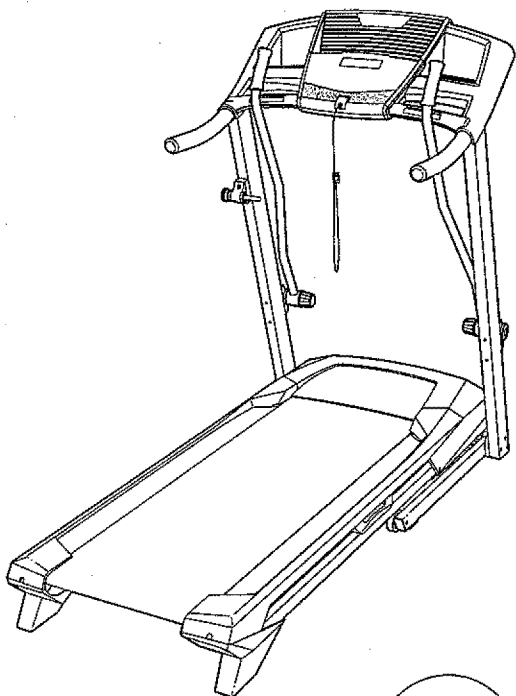
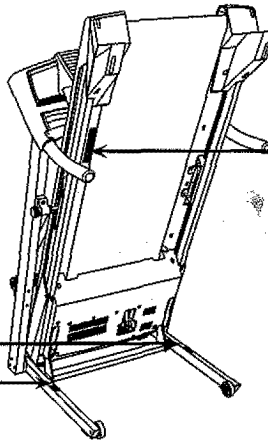
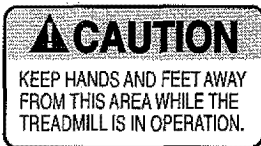

TABLE OF CONTENTS

WARNING DECAL PLACEMENT	2
IMPORTANT PRECAUTIONS	3
BEFORE YOU BEGIN	5
PART IDENTIFICATION CHART	6
ASSEMBLY	7
OPERATION AND ADJUSTMENT	13
HOW TO FOLD AND MOVE THE TREADMILL	19
TROUBLESHOOTING	20
EXERCISE GUIDELINES	23
PART LIST	24
EXPLODED DRAWING	25
ORDERING REPLACEMENT PARTS	Back Cover
90-DAY FULL WARRANTY	Back Cover

WARNING DECAL PLACEMENT

This drawing shows the location(s) of the warning decal(s). If a decal is missing or illegible, call 1-888-533-1333 and request a free replacement decal. Apply the decal in the location shown. Note: The decal(s) may not be shown at actual size.



WARNING

Protect yourself and others from risk of serious injury. Read the user's manual and:

-  Stand only on the side rails when starting or stopping treadmill.
- Change speed in small increments.
- Hold handrails to prevent falling, and always wear the safety clip while operating treadmill.
- Stop if you feel faint, dizzy, or short of breath.
- Fully engage storage lock before treadmill is moved or stored.
- Reduce incline to its lowest level before locking treadmill into storage position.

 Never allow children on or around treadmill.

• Remove key when not in use.

 Keep clothing, fingers, and hair away from moving belt.

• Never try to adjust or fix the belt while it is moving.

 Always wear athletic shoes while operating treadmill.

IMPORTANT PRECAUTIONS

▲ WARNING: To reduce the risk of serious injury, read all important precautions and instructions in this manual and all warnings on your treadmill before using your treadmill. Sears assumes no responsibility for personal injury or property damage sustained by or through the use of this product.

1. Before beginning any exercise program, consult your physician. This is especially important for persons over age 35 or persons with pre-existing health problems.
2. It is the responsibility of the owner to ensure that all users of this treadmill are adequately informed of all warnings and precautions.
3. Use the treadmill only as described.
4. Keep the treadmill indoors, away from moisture and dust. Do not put the treadmill in a garage or covered patio, or near water.
5. Place the treadmill on a level surface, with at least 8 ft. (2.4 m) of clearance behind it and 2 ft. (0.6 m) on each side. Do not place the treadmill on any surface that blocks air openings. To protect the floor or carpet from damage, place a mat under the treadmill.
6. Do not operate the treadmill where aerosol products are used or where oxygen is being administered.
7. Keep children under age 12 and pets away from the treadmill at all times.
8. The treadmill should be used only by persons weighing 300 lbs. (136 kg) or less.
9. Never allow more than one person on the treadmill at a time.
10. Wear appropriate exercise clothes while using the treadmill. Do not wear loose clothes that could become caught in the treadmill. Athletic support clothes are recommended for both men and women. *Always wear athletic shoes. Never use the treadmill with bare feet, wearing only stockings, or in sandals.*
11. When connecting the power cord (see page 13), plug the power cord into a surge suppressor (not included) and plug the surge suppressor into a grounded circuit capable of carrying 15 or more amps. No other appliance should be on the same circuit. Do not use an extension cord.
12. Use only a single-outlet surge suppressor that meets all of the specifications described on page 13. To purchase a surge suppressor, see your local Sears store or call the telephone number on the back cover of this manual and order part number 146148, or see your local electronics store.
13. Failure to use a properly-functioning surge suppressor could result in damage to the control system of the treadmill. If the control system is damaged, the walking belt may slow, accelerate, or stop unexpectedly, which may result in a fall and serious injury.
14. Keep the power cord and the surge suppressor away from heated surfaces.
15. Never move the walking belt while the power is turned off. Do not operate the treadmill if the power cord or plug is damaged, or if the treadmill is not working properly. (See TROUBLESHOOTING on page 20 if the treadmill is not working properly.)
16. Read, understand, and test the emergency stop procedure before using the treadmill (see HOW TO TURN ON THE POWER on page 15).
17. Never start the treadmill while you are standing on the walking belt. Always hold the handrails or upper body arms while using the treadmill.
18. The treadmill is capable of high speeds. Adjust the speed in small increments to avoid sudden jumps in speed.
19. The heart rate monitor is not a medical device. Various factors, including the user's movement, may affect the accuracy of heart rate readings. The heart rate monitor is intended only as an exercise aid in determining heart rate trends in general.

20. Never leave the treadmill unattended while it is running. Always remove the key, unplug the power cord, and press the power switch into the off position when the treadmill is not in use. (See the drawing on page 5 for the location of the power switch.)
21. Do not attempt to raise, lower, or move the treadmill until it is properly assembled. (See ASSEMBLY on page 7 and HOW TO FOLD AND MOVE THE TREADMILL on page 19.) You must be able to safely lift 45 lbs. (20 kg) to raise, lower, or move the treadmill.
22. When folding or moving the treadmill, make sure that the storage latch is holding the frame securely in the storage position.
23. Never insert any object into any opening on the treadmill.
24. Inspect and properly tighten all parts of the treadmill regularly.

25. **DANGER** Always unplug the power cord immediately after use, before cleaning the treadmill, and before performing the maintenance and adjustment procedures described in this manual. Never remove the motor hood unless instructed to do so by an authorized service representative. Servicing other than the procedures in this manual should be performed by an authorized service representative only.
26. This treadmill is intended for home use only. Do not use this treadmill in a commercial, rental, or institutional setting.
27. Over exercising may result in serious injury or death. If you feel faint or if you experience pain while exercising, stop immediately and cool down.

SAVE THESE INSTRUCTIONS

BEFORE YOU BEGIN

Thank you for selecting the new PROFORM® CROSSWALK 395 treadmill. The CROSSWALK 395 treadmill provides an impressive selection of features designed to make your workouts at home more effective and enjoyable.

For your benefit, read this manual carefully before you use the treadmill. If you have questions after reading

this manual, please see the back cover of this manual. To help us assist you, note the product model number and serial number before contacting us. The model number and the location of the serial number decal are shown on the front cover of this manual.

Before reading further, please familiarize yourself with the parts that are labeled in the drawing below.

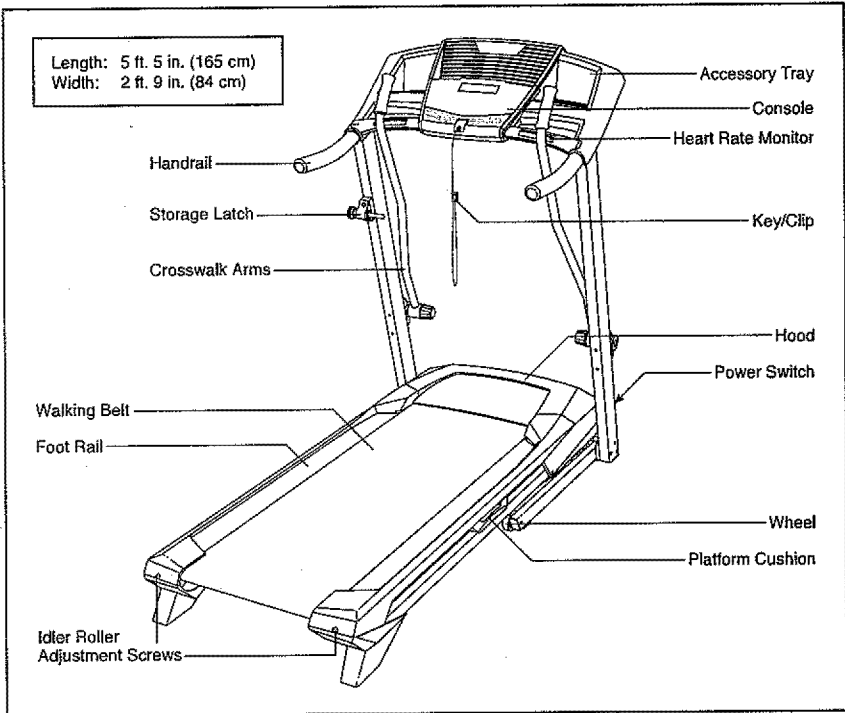

PART IDENTIFICATION CHART

Use the drawings below to identify small parts used for assembly. The number in parentheses below each drawing is the key number of the part, from the PART LIST near the end of this manual. The number following the key number is the quantity used for assembly. Note: If a part is not in the hardware kit, check to see if it is pre-attached. If it is not, call 1-888-533-1333. Extra hardware may be included.

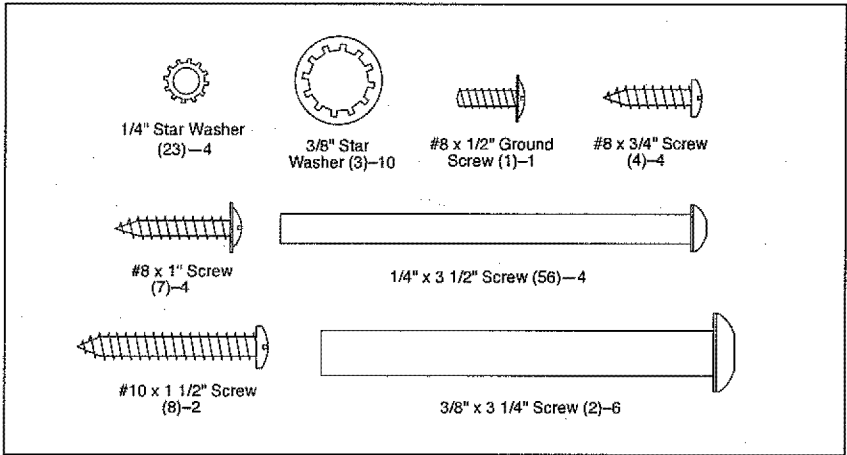

ASSEMBLY

- Assembly requires two persons.
- Place all parts in a cleared area and remove the packing materials. Do not dispose of the packing materials until you finish assembly.
- The underside of the walking belt is coated with high-performance lubricant. After shipping, there may be some lubricant on top of the walking belt or on the shipping carton. This is normal. If there is lubricant on top of the walking belt, wipe it off with a soft cloth and a mild, non-abrasive cleaner.

- To identify small parts, see page 6.

- Assembly requires the following tools:

the included hex keys



one Phillips screwdriver



scissors



- To avoid damaging parts, do not use power tools.

1. Make sure that the power cord is unplugged.

Remove and discard the two screws (A) and the shipping bracket (B) from the right side of the Base (74). Then, remove and discard the screws and shipping bracket (not shown) from the left side of the Base.

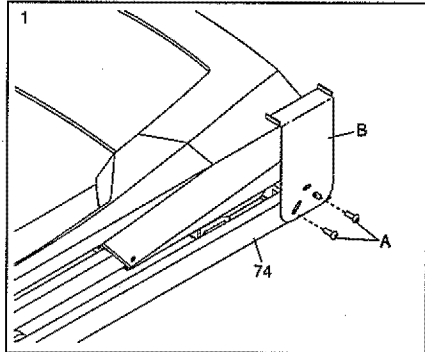

2. With the help of a second person, tip the treadmill onto its left side. Partially pivot the Base (74) to help stabilize the treadmill.

Pull the Upright Wire (63) and the ground wire through the indicated hole in the Base (74).

Attach the ground wire to the Base (74) with a #8 x 1/2" Ground Screw (1).

See the inset drawing. Cut the plastic tie near the Upright Wire (63). Be careful not to damage the Upright Wire.

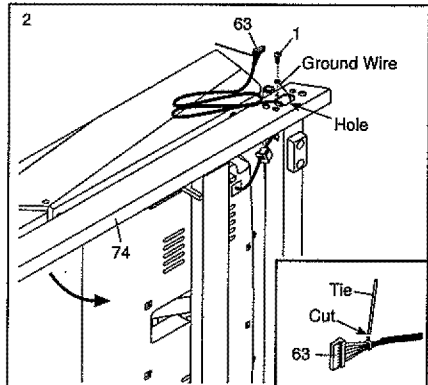

3. Press a Base Cap (70) into the Base (74).

Make sure that the Upright Grommet (73) is pressed into the square hole in the Base (74).

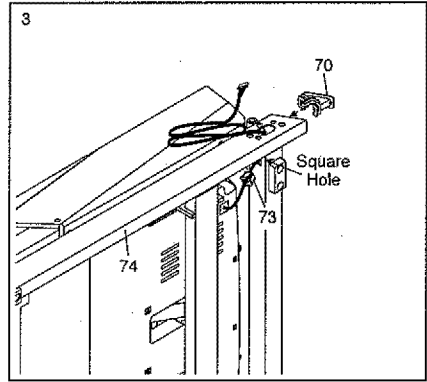

4. Identify the Right Upright (76), which is marked "Right." Have a second person hold the Right Upright near the Base (74).

See the inset drawing. Tie the wire tie in the Right Upright (76) securely around the end of the Upright Wire (63). Then, insert the Upright Wire into the lower end of the Right Upright as you pull the other end of the wire tie through the Right Upright.

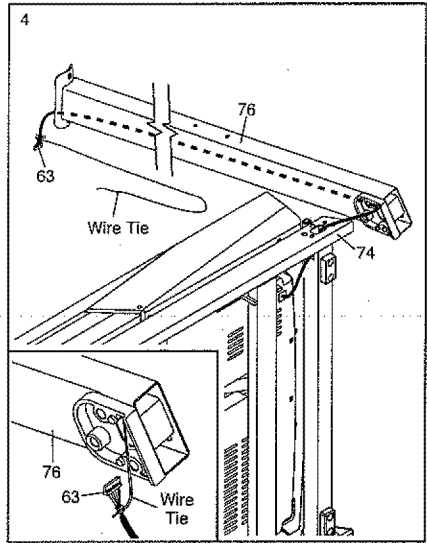

5. Hold the Right Upright (76) against the Base (74). Be careful not to pinch the wires. Partially tighten three 3/8" x 3 1/4" Screws (2) with three 3/8" Star Washers (3) into the Right Upright and the Base; do not fully tighten the Screws yet.

With the help of a second person, tip the treadmill onto its right side. Press in a Base Cap (not shown) and attach the Left Upright (not shown) as described in steps 3 and 5. Note: There are no wires on the left side.

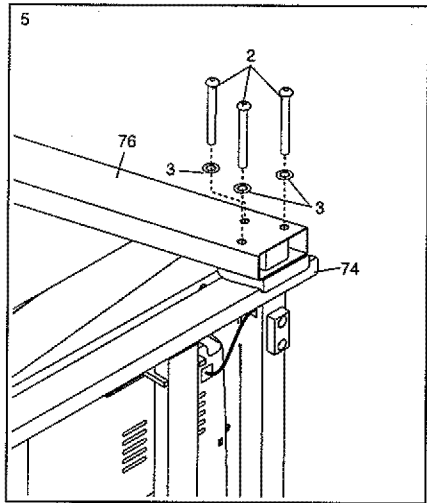

6. Identify the Left and Right Handrails (59, 64), which are marked "Left" and "Right." Remove the four 5/16" x 3/4" Screws (5) and four 5/16" Star Washers (6) from the bottoms and sides of each Handrail.

Hold the Right Handrail (64) near the Right Upright (76). Insert the wire tie on the Upright Wire (63) through the hole in the bottom and out of the hole in the side of the Left Handrail as shown. Then, pull the Upright Wire through the Right Handrail.

Attach the Right Handrail (64) to the Right Upright (76) with two of the 5/16" x 3/4" Screws (5) and two of the 3/8" Star Washers (6) that you just removed. Make sure not to pinch the Upright Wire (63). Start both Screws, and then tighten them.

Attach the Left Handrail (59) to the Left Upright (66) as described above. Note: There are no wires on the left side.

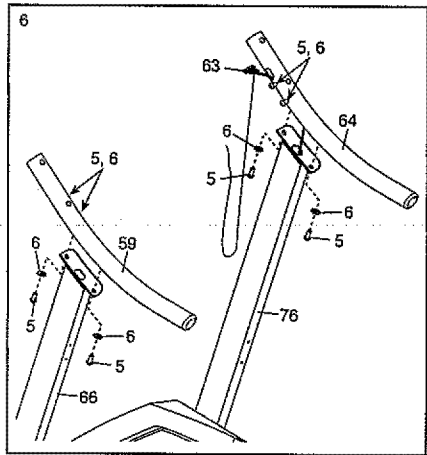

7. Position the Console Crossbar (61) between the Left and Right Handrails (59, 64) with the Console Ground Wire (47) positioned as shown.

Attach the Console Crossbar (61) to the Left and Right Handrails (59, 64) with the other four 5/16" x 3/4" Screws (5) and the other four 5/16" Star Washers (6) that you removed in step 6. Start all four Screws, and then tighten them.

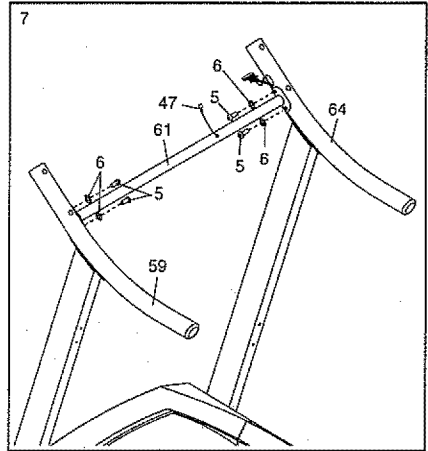

8. With the help of a second person, hold the console assembly near the Right Handrail (64).

Connect the Upright Wire (63) to the console wire. See the inset drawing. The connectors should slide together easily and snap into place. If they do not, turn one connector and try again. **IF YOU DO NOT CONNECT THE CONNECTORS PROPERLY, THE CONSOLE MAY BECOME DAMAGED WHEN YOU TURN ON THE POWER.** Then, remove the wire tie from the Upright Wire.

Connect the Console Ground Wire (47) on the Console Crossbar (61) to the ground wire on the console.

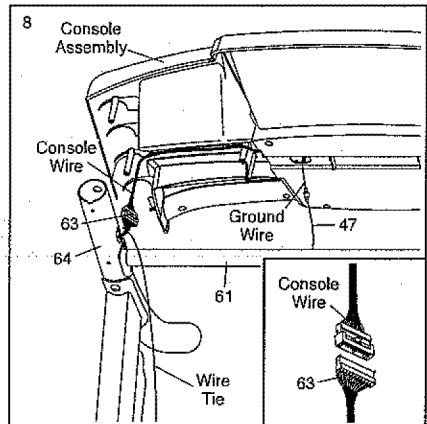

9. Insert the wires into the Right Handrail (64) through the indicated hole as you set the console assembly on the Left and Right Handrails (59, 64). Make sure that no wires are pinched.

Attach the console assembly with four #8 x 3/4" Screws (4). Start all four Screws, and then tighten them. Do not overtighten the Screws.

See assembly step 5. Firmly tighten the six 3/8" x 3 1/4" Screws (2) on the lower ends of the Left and Right Uprights (66, 76) (only one side is shown).

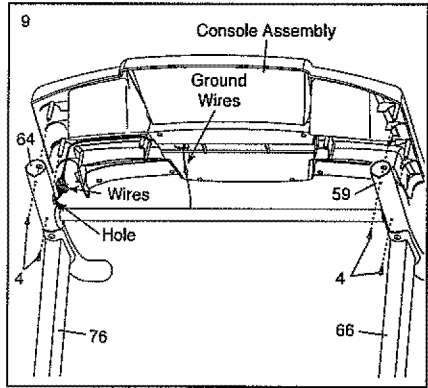

10. Attach the two Console Clamps (83) to the console assembly with four #8 x 1" Screws (7).

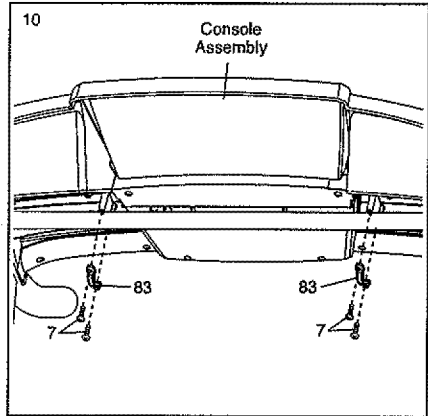

11. Identify the Left and Right Upper Body Arms (84, 85).

Make sure that the Left Upper Body Arm (84) is positioned as shown. Attach the Left Upper Body Arm to the Left Upright (66) with two 1/4" x 3 1/2" Screws (56), two 1/4" Star Washers (23), and two 3/8" Star Washers (3) as shown. Do not overtighten the Screws.

Attach the Right Upper Body Arm (85) as described above.

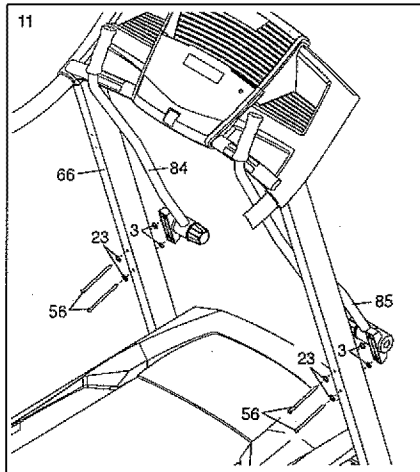

12. Attach the Latch Housing (67) with the Latch Spacer (82) to the Left Upright (66) with two #10 x 1 1/2" Screws (8); make sure that the large hole in the Latch Housing is on the indicated side. Start both Screws, and then tighten them. Be careful not to overtighten the Screws.

Locate the Latch Pin Assembly (68). Remove the knob from the pin. Make sure that the collar and the spring are on the pin. (Note: If there are two collars, place one on each side of the spring.) Insert the pin into the Latch Housing (67). Then, tighten the knob onto the pin.

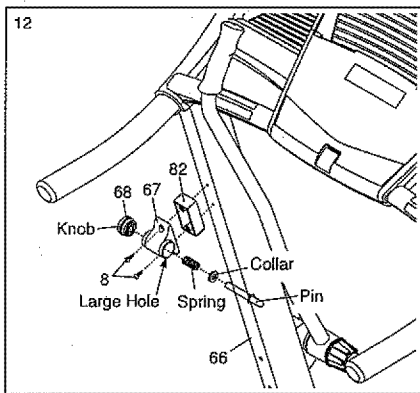

13. Make sure that all parts are properly tightened before you use the treadmill. If there are sheets of plastic on the treadmill decals, remove the plastic. To protect the floor or carpet, place a mat under the treadmill. Note: Extra hardware may be included. Keep the included hex keys in a secure place; one of the hex keys is used to adjust the walking belt (see pages 21 and 22).

OPERATION AND ADJUSTMENT

HOW TO PLUG IN THE POWER CORD

⚠ DANGER: Improper connection of the equipment-grounding conductor increases the risk of electric shock. Check with a qualified electrician or serviceman if you are unsure whether the product is properly grounded. Do not modify the plug—if it will not fit the outlet, have a proper outlet installed by a qualified electrician.

Your treadmill, like other electronic equipment, can be damaged by sudden voltage changes in your home's power. To decrease the risk of damaging your treadmill, always use a surge suppressor with your treadmill (see drawing 1 at the right). To purchase a surge suppressor, see precaution 12 on page 3.

Use only a single-outlet surge suppressor that is UL 1449 listed as a transient voltage surge suppressor (TVSS). The surge suppressor must have a UL suppressed voltage rating of 400 volts or less and a minimum surge dissipation of 450 joules. The surge suppressor must be electrically rated for 120 volts AC and 15 amps. There must be a monitoring light on the surge suppressor to indicate whether it is functioning properly. Failure to use a properly-functioning surge suppressor could damage the control system of the treadmill (see precaution 13 on page 3).

This product must be grounded. If it should malfunction or break down, grounding provides a path of least resistance for electric current to reduce the risk of electric shock. This product's power cord has an equipment-grounding conductor and a grounding plug. Plug the power cord into a surge suppressor, and plug the surge suppressor into an appropriate outlet that is properly installed and grounded in accordance with all local codes and ordinances. **IMPORTANT:** The treadmill is not compatible with GFCI-equipped outlets and may not be compatible with AFCI-equipped outlets.

This product is for use on a nominal 120-volt circuit (see drawing 1). A temporary adapter may be used to connect the surge suppressor to a 2-pole receptacle if a properly-grounded outlet is not available (see drawing 2).

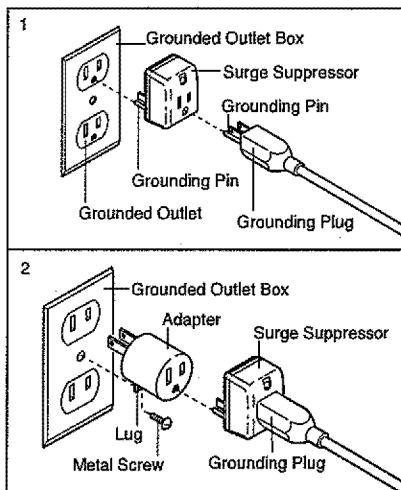

The temporary adapter should be used only until a properly-grounded outlet (see drawing 1) can be installed by a qualified electrician.

The green-colored rigid ear, lug, or the like extending from the adapter must be connected to a permanent ground such as a grounded outlet box cover. The adapter must be held in place by a metal screw. Some 2-pole receptacle outlet box covers are not grounded. Contact a qualified electrician to determine if the outlet box cover is grounded before using an adapter.

CONSOLE DIAGRAM

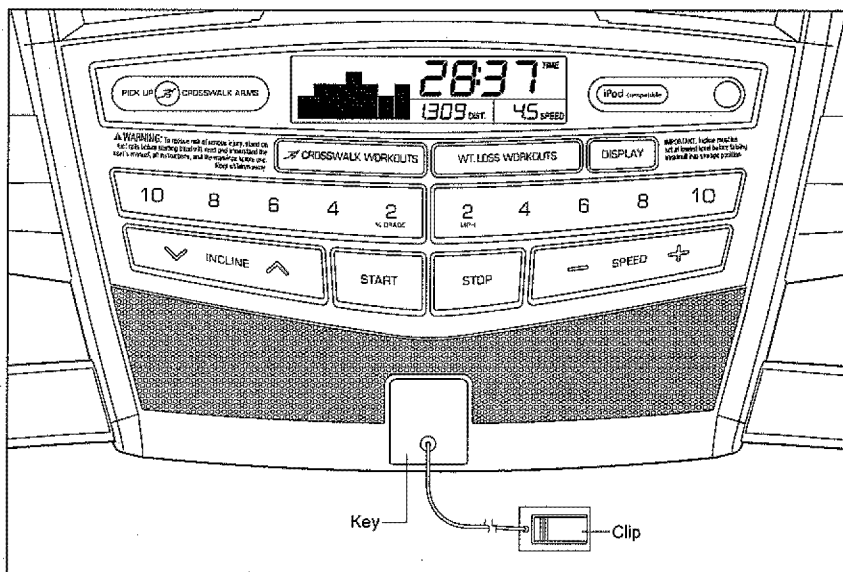

FEATURES OF THE CONSOLE

The treadmill console offers an impressive array of features designed to make your workouts more effective and enjoyable.

When you use the manual mode, you can change the speed and incline of the treadmill with the touch of a button. As you exercise, the console will display instant exercise feedback. You can even measure your heart rate using the handgrip heart rate monitor.

In addition, the console offers sixteen preset workouts. Eight of these use the crosswalk arms, and the other eight are designed to help you meet your weight-loss goals. Each workout automatically controls the speed and incline of the treadmill as it guides you through an effective exercise session.

To turn on the power, see page 15. To use the manual mode, see page 15. To use a preset workout, see page 17. To use the information mode, see page 18.

IMPORTANT: If there is a sheet of clear plastic on the console, remove the plastic. To prevent damage to the walking platform, wear clean athletic shoes while using the treadmill. The first time you use the treadmill, observe the alignment of the walking belt, and center the walking belt if necessary (see pages 21 and 22).

Note: The console can display speed and distance in either miles or kilometers. To find out which unit of measurement is selected or to change the unit of measurement, see THE INFORMATION MODE on page 18. Note: For simplicity, all instructions in this section refer to miles.

HOW TO TURN ON THE POWER

IMPORTANT: If the treadmill has been exposed to cold temperatures, allow it to warm to room temperature before turning on the power. If you do not do this, you may damage the console displays or other electrical components.

Plug in the power cord (see page 13). Next, locate the power switch on the treadmill frame near the power cord. Press the power switch into the reset position.

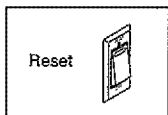

IMPORTANT: The console features a display demo mode, designed to be used if the treadmill is displayed in a store. If the displays light as soon as you plug in the power cord and press the power switch into the reset position, the demo mode is turned on. To turn off the demo mode, hold down the Stop button for a few seconds. If the displays remain lit, see THE INFORMATION MODE on page 18 to turn off the demo mode.

Next, stand on the foot rails of the treadmill. Find the clip attached to the key (see the drawing on page 14) and slide the clip onto the waistband of your clothes. Then, insert the key into the console. After a moment, the displays will light. **IMPORTANT:** In an emergency situation, the key can be pulled from the console, causing the walking belt to slow to a stop. Test the clip by carefully taking a few steps backward; if the key is not pulled from the console, adjust the position of the clip.

HOW TO USE THE MANUAL MODE

1. Insert the key into the console.

See HOW TO TURN ON THE POWER at the left.

2. Select the manual mode.

When the key is inserted, the manual mode will be selected. If a preset workout has been selected, remove the key and then reinsert it.

3. Start the walking belt.

To start the walking belt, press the Start button, the Speed increase button, or one of the speed buttons numbered 2 through 10.

If you press the Start button or the Speed increase button, the walking belt will begin to move at 1 mph. As you exercise, change the speed of the walking belt as desired by pressing the Speed increase and decrease buttons. Each time you press a button, the speed setting will change by 0.1 mph; if you hold down a button, the speed setting will change in increments of 0.5 mph. Note: After you press a button, it may take a moment for the walking belt to reach the selected speed setting.

If you press one of the numbered speed buttons, the walking belt will gradually change speed until it reaches the selected speed setting.

To stop the walking belt, press the Stop button. The time will begin to flash in the display. To restart the walking belt, press the Start button or the Speed increase button.

4. Change the incline of the treadmill as desired.

To change the incline of the treadmill, press the Incline increase or decrease buttons.

Each time you press the Incline increase or decrease button, the incline will change by 0.5%. Note: After you press a button, it may take a moment for the treadmill to reach the selected incline setting.



5. Follow your progress with the displays.

The far left display—

When you select the manual mode, the matrix will display a track that represents 1/4 mile (400 m). As you exercise, the indicators around the track will appear in succession until the entire track appears. The track will then disappear and the indicators will again begin to appear in succession.

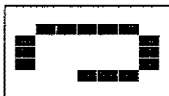

The lower left display—

As you exercise, the lower left display can show the elapsed time and the distance that you have walked or run. The lower left display will also show the incline of the treadmill each time the incline level changes.



The lower right display—

The lower right display can show the approximate number of calories that you have burned and the speed of the walking belt. The display also shows your heart rate when you use the handgrip heart rate monitor (see step 6).

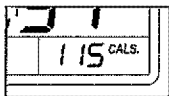

The upper display—

The upper display can show the elapsed time, the distance that you have walked or run, the approximate number of calories that you have burned, or the speed of the walking belt. Press the Display button repeatedly until the upper display shows the information that you are most interested in viewing. Note: While information is shown in the upper display, the same information will not be shown in the lower displays.

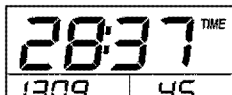

To reset the displays, press the Stop button, remove the key, and then reinsert the key.

6. Measure your heart rate if desired.

Before using the handgrip heart rate monitor, remove the sheets of clear plastic from the metal contacts on the pulse bar. In addition, make sure that your hands are clean.

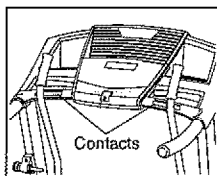

To measure your heart rate, stand on the foot rails and hold the metal contacts on the handrail. Avoid moving your hands. When your pulse is detected, a heart symbol in the lower right display will flash each time your heart beats, one or two dashes will appear, and then your heart rate will be shown. For the most accurate heart rate reading, continue to hold the contacts for about 15 seconds.

7. When you are finished exercising, remove the key from the console.

Step onto the foot rails, press the Stop button, and adjust the incline of the treadmill to the lowest setting. The incline must be at the lowest setting or you may damage the treadmill when you fold it to the storage position. Next, remove the key from the console and put it in a secure place.

When you are finished using the treadmill, press the power switch into the off position and unplug the power cord. **IMPORTANT:** If you do not do this, the treadmill's electrical components may wear prematurely.

HOW TO USE A PRESET WORKOUT

1. Insert the key into the console.

See HOW TO TURN ON THE POWER on page 15.

2. Select a preset workout.

To select a preset workout, press the Crosswalk Workouts button or the Wt. Loss Workouts button repeatedly until the number of the desired workout appears in the upper display.



When you select a preset workout, the incline level of the workout will flash in the lower left display, the speed setting will flash in the lower right display, and then the workout length will appear in the lower left display. In addition, a profile of the speed settings of the workout will appear in the far left display.

3. Press the Start button or the Speed increase button to start the workout.

A moment after you press the button, the treadmill will automatically adjust to the first speed and incline settings of the workout. Hold the handrails and begin walking.

Each workout is divided into 30 one-minute segments. One speed setting and one incline setting are programmed for each segment. Note: The same speed setting and/or incline setting may be programmed for consecutive segments.

During the workout, the profile will show your progress. The flashing segment of the profile represents the current segment of the workout. The height of the flashing segment indicates the speed setting for the current segment. At the end of each segment, a tone will sound and the next segment

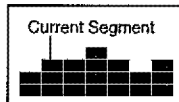

of the profile will begin to flash. If a new speed and/or incline setting is programmed for the next segment, the new speed and/or incline setting will appear in the displays. The treadmill will then automatically adjust to the new speed and/or incline setting.

If you have selected a crosswalk workout, you will be prompted to use the crosswalk arms. When the crosswalk indicator on the console lights up, move the crosswalk arms forward and backward as you walk on the treadmill. This action exercises your arms, shoulders, and back for a total body workout.

The workout will continue in this way until the last segment of the profile flashes in the display and the last segment ends. The walking belt will then slow to a stop.

If the speed or incline setting is too high or too low at any time during the workout, you can manually override the setting by pressing the speed or incline buttons; however, when the next segment of the workout begins, the treadmill will automatically adjust to the speed and incline settings for the next segment.

To stop the workout at any time, press the Stop button. To restart the workout, press the Start button. The walking belt will begin to move at 1 mph. When the next segment of the workout begins, the treadmill will automatically adjust to the speed and incline settings for the next segment.

4. Follow your progress with the displays.

See step 5 on page 16.

5. Measure your heart rate if desired.

See step 6 on page 16.

6. When you are finished exercising, remove the key from the console.

See step 7 on page 16.

THE INFORMATION MODE

The console features an information mode that keeps track of the total distance that the walking belt has moved and the total number of hours that the treadmill has been used. The information mode also allows you to select a measurement system of miles or kilometers, and to turn the display demo mode on and off.

To select the information mode, hold down the Stop button while inserting the key into the console and then release the Stop button. When the information mode is selected, the following information will be shown:

An "E" for English miles or an "M" for metric kilometers will appear in the lower right display. Press the Speed increase button to change the unit of measurement if desired.

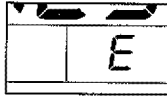

The lower left display will show the total number of miles (or kilometers) that the walking belt has moved.

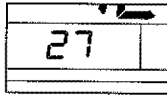

The upper display will show the total number of hours the treadmill has been used.

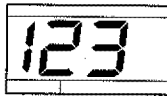

The console features a display demo mode, designed to be used if the treadmill is displayed in a store. While the demo mode is turned on, the console will function normally when you plug in the power cord, press the power switch into the reset position, and insert the key into the console. However, when you remove the key, the displays will remain lit, although the buttons will not function. If the demo mode is turned on, a "d" will appear in the lower right display while the information mode is selected. To turn on or off the demo mode, press the Speed decrease button.

To exit the information mode, remove the key from the console.

HOW TO USE THE CROSSWALK ARMS

As you walk on the treadmill, you can hold the handrails or use the crosswalk arms. To exercise your arms, shoulders, and back for a total body workout, move the crosswalk arms forward and backward as you walk on the treadmill.

To vary the intensity of your upper body exercise, the resistance of the crosswalk arms can be adjusted. To increase the resistance, turn the resistance knobs clockwise; to decrease the resistance, turn the knobs counterclockwise.

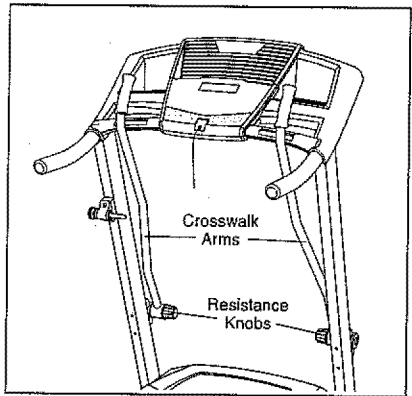

HOW TO FOLD AND MOVE THE TREADMILL

HOW TO FOLD THE TREADMILL

Before folding the treadmill, adjust the incline to the lowest position. If you do not do this, you may damage the treadmill when you fold it. Remove the key and unplug the power cord. **CAUTION:** You must be able to safely lift 45 lbs. (20 kg) to raise, lower, or move the treadmill.

1. Hold the metal frame firmly in the location shown by the arrow below. **CAUTION:** Do not hold the frame by the plastic foot rails. Bend your legs and keep your back straight.

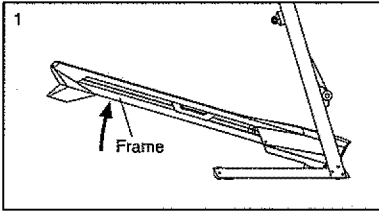

2. Hold the frame firmly with your right hand. Pull the latch knob to the left and hold it. Raise the frame until the hole in the platform cushion is aligned with the latch pin. Then, slowly release the latch knob; make sure that the latch pin is fully inserted into the platform cushion.

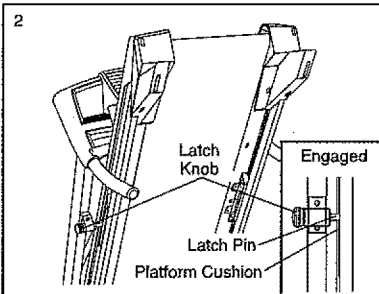

To protect the floor or carpet, place a mat under the treadmill. Keep the treadmill out of direct sunlight. Do not leave the treadmill in the storage position in temperatures above 85° F (30° C).

HOW TO MOVE THE TREADMILL

Before moving the treadmill, fold it as described at the left. **CAUTION:** Make sure that the latch pin is fully inserted into the platform cushion. Moving the treadmill may require two people.

1. Hold the frame and one of the handrails, and place one foot against a wheel.

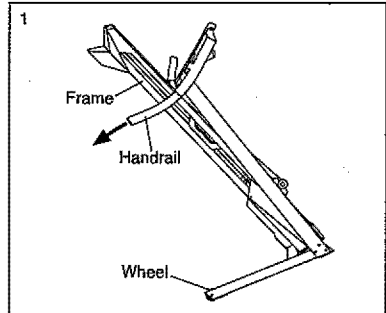

2. Pull back on the handrail until the treadmill will roll on the wheels, and carefully move it to the desired location. **CAUTION:** Do not move the treadmill without tipping it back, do not pull on the frame, and do not move the treadmill over an uneven surface.

3. Place one foot against a wheel, and carefully lower the treadmill.

HOW TO LOWER THE TREADMILL FOR USE

1. See drawing 2. Hold the upper end of the treadmill with your right hand. Pull the latch knob to the left and hold it. Next, lower the frame until it is past the latch pin. Make sure that the pin does not hit against the foot rail. Then, release the latch knob.
2. See drawing 1 at the left. Hold the metal frame firmly with both hands, and lower it to the floor. **CAUTION:** Do not hold the frame by the plastic foot rails, and do not drop the frame. Bend your legs and keep your back straight.

TROUBLESHOOTING

Most treadmill problems can be solved by following the simple steps below. Find the symptom that applies, and follow the steps listed. If further assistance is needed, see the front cover of this manual.

SYMPTOM: The power does not turn on

- Make sure that the power cord is plugged into a surge suppressor and that the surge suppressor is plugged into a properly-grounded outlet (see page 13). Use only a single-outlet surge suppressor that meets all of the specifications described on page 13. **IMPORTANT: The treadmill is not compatible with GFCI-equipped outlets and may not be compatible with AFCI-equipped outlets.**
- After the power cord has been plugged in, make sure that the key is inserted into the console.
- Check the power switch located on the treadmill frame near the power cord. If the switch protrudes as shown, the switch has tripped. To reset the power switch, wait for five minutes and then press the switch back in.

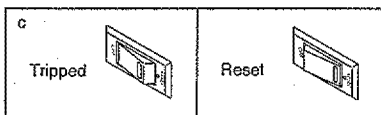

SYMPTOM: The power turns off during use

- Check the power switch (see the drawing above). If the switch has tripped, wait for five minutes and then press the switch back in.
- Make sure that the power cord is plugged in. If the power cord is plugged in, unplug it, wait for five minutes, and then plug it back in.

- Remove the key from the console, and then reinsert it.
- If the treadmill still will not run, please see the front cover of this manual.

SYMPTOM: The console displays remain lit when you remove the key from the console

- The console features a display demo mode, designed to be used if the treadmill is displayed in a store. If the displays remain lit when you remove the key, the demo mode is turned on. To turn off the demo mode, hold down the Stop button for a few seconds. If the displays are still lit, see THE INFORMATION MODE on page 18 to turn off the demo mode.

SYMPTOM: The displays of the console do not function properly

- Remove the key from the console and **UNPLUG THE POWER CORD**. Next, remove the five indicated #8 x 3/4" Screws (4).

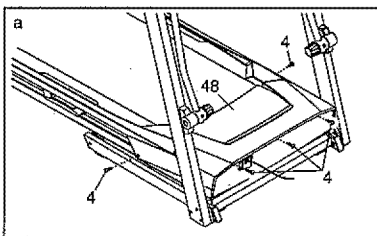

Carefully lift the Motor Hood (48) upward, and then slide it forward and off. Make sure that the Motor Hood does not get caught by the tabs on the sides of the Motor Hood.

Locate the Reed Switch (33) and the Magnet (32) on the right side of the Pulley (31). Turn the Pulley until the Magnet is aligned with the Reed Switch. Make sure that the gap between the Magnet and the Reed Switch is about 1/8 in. (3 mm). If necessary, loosen the #8 x 3/4" Truss Head Screw (14), move the Reed Switch slightly, and then retighten the Screw. Carefully slide the Motor Hood (not shown) back on by lining up the guides. Reattach the Motor Hood with the five #8 x 3/4" Screws (not shown). Then, plug in the power cord, insert the key, and run the treadmill for a few minutes to check for a correct speed reading.

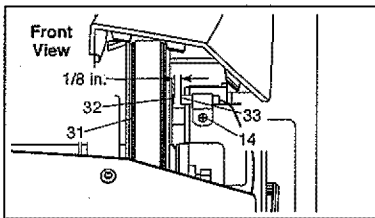

SYMPTOM: The incline of the treadmill does not change correctly

- a. Hold down the Stop button and the Speed increase button, insert the key into the console, and then release the Stop button and the Speed increase button. Press the Stop button and then press the Incline increase or decrease button. The treadmill will automatically rise to the maximum incline level and then return to the minimum level. This will recalibrate the incline system. If the incline does not begin calibrating, press the Stop button again, and then press the Incline increase or decrease button again. When the incline is calibrated, remove the key from the console.

SYMPTOM: The walking belt slows when walked on

- a. Use only a single-outlet surge suppressor that meets all of the specifications described on page 13.

- b. If the walking belt is overtightened, treadmill performance may decrease and the walking belt may become damaged. Remove the key and **UNPLUG THE POWER CORD**. Using the hex key, turn both idler roller screws counterclockwise, 1/4 of a turn. When the walking belt is properly tightened, you should be able to lift each edge of the walking belt 2 to 3 in. (5 to 7 cm) off the walking platform. Be careful to keep the walking belt centered. Then, plug in the power cord, insert the key, and run the treadmill for a few minutes. Repeat until the walking belt is properly tightened.

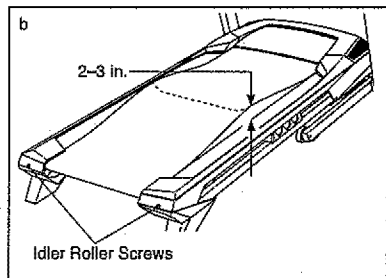

- c. Your treadmill features a walking belt coated with high-performance lubricant. **IMPORTANT:** Never apply silicone spray or other substances to the walking belt or the walking platform unless instructed to do so by an authorized service representative. Such substances may deteriorate the walking belt and cause excessive wear. If you suspect that the walking belt needs more lubricant, see the front cover of this manual.
- d. If the walking belt still slows when walked on, see the front cover of this manual.

SYMPTOM: The walking belt is off-center or slips when walked on

- a. If the walking belt is off-center, first remove the key and **UNPLUG THE POWER CORD**. If the walking belt has shifted to the left, use the hex key to turn the left idler roller screw clockwise 1/2 of a turn; if the walking belt has shifted to the right, turn the left idler roller screw counterclockwise 1/2 of a turn. Be careful not to overtighten the walking belt. Then, plug in the power cord, insert the key, and run the treadmill for a few minutes. Repeat until the walking belt is centered.

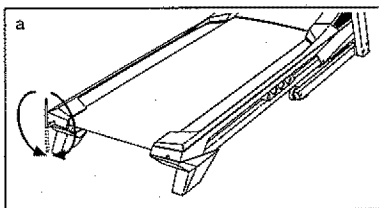

- b. If the walking belt slips when walked on, first remove the key and **UNPLUG THE POWER CORD**. Using the hex key, turn both idler roller screws clockwise, 1/4 of a turn. When the walking belt is correctly tightened, you should be able to lift each edge of the walking belt 2 to 3 in. (5 to 7 cm) off the walking platform. Be careful to keep the walking belt centered. Then, plug in the power cord, insert the key, and carefully walk on the treadmill for a few minutes. Repeat until the walking belt is properly tightened.

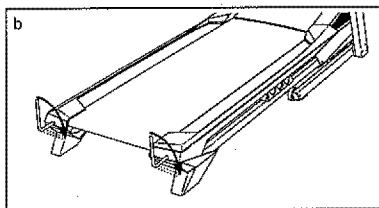

SYMPTOM: The upperbody arms squeak during use

- a. (Note: Correcting this problem requires a small amount of marine grease, available at hardware stores.) Turn the resistance knob (A) counterclockwise and remove it. Next, remove the resistance cone (B) and the upper body arm (C), along with the resistance plate (D), plastic spacer (E), spring washer (F), washers (G), and thrust bearing (H). (Note: If the resistance plate (D) comes out of the resistance cone (B), press it back in.) Apply a thin layer of white marine grease to the outer surface of the resistance cone (B). Then reattach all parts in the order shown below.

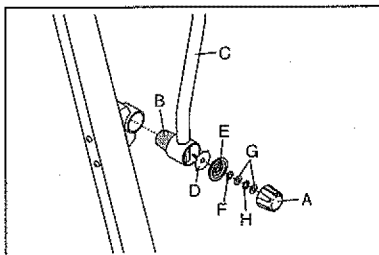

EXERCISE GUIDELINES

⚠ WARNING: Before beginning this or any exercise program, consult your physician. This is especially important for persons over age 35 or persons with pre-existing health problems.

The heart rate monitor is not a medical device. Various factors may affect the accuracy of heart rate readings. The heart rate monitor is intended only as an exercise aid in determining heart rate trends in general.

These guidelines will help you to plan your exercise program. For detailed exercise information, obtain a reputable book or consult your physician. Remember, proper nutrition and adequate rest are essential for successful results.

EXERCISE INTENSITY

Whether your goal is to burn fat or to strengthen your cardiovascular system, exercising at the proper intensity is the key to achieving results. You can use your heart rate as a guide to find the proper intensity level. The chart below shows recommended heart rates for fat burning and aerobic exercise.

165	155	145	140	130	125	115	♥
145	138	130	125	118	110	103	♥
125	120	115	110	105	95	90	♥
20	30	40	50	60	70	80	

To find the proper intensity level, find your age at the bottom of the chart (ages are rounded off to the nearest ten years). The three numbers listed above your age define your "training zone." The lowest number is the heart rate for fat burning, the middle number is the heart rate for maximum fat burning, and the highest number is the heart rate for aerobic exercise.

Burning Fat—To burn fat effectively, you must exercise at a low intensity level for a sustained period of time. During the first few minutes of exercise, your body uses carbohydrate calories for energy. Only after the first few minutes of exercise does your body begin to use stored fat calories for energy. If your goal is to burn fat, adjust the intensity of your exercise until your heart rate is near the lowest number in your training zone. For maximum fat burning, exercise with your heart rate near the middle number in your training zone.

Aerobic Exercise—If your goal is to strengthen your cardiovascular system, you must perform aerobic exercise, which is activity that requires large amounts of oxygen for prolonged periods of time. For aerobic exercise, adjust the intensity of your exercise until your heart rate is near the highest number in your training zone.

WORKOUT GUIDELINES

Warming Up—Start with 5 to 10 minutes of stretching and light exercise. A warm-up increases your body temperature, heart rate, and circulation in preparation for exercise.

Training Zone Exercise—Exercise for 20 to 30 minutes with your heart rate in your training zone. (During the first few weeks of your exercise program, do not keep your heart rate in your training zone for longer than 20 minutes.) Breathe regularly and deeply as you exercise—never hold your breath.

Cooling Down—Finish with 5 to 10 minutes of stretching. Stretching increases the flexibility of your muscles and helps to prevent post-exercise problems.

EXERCISE FREQUENCY

To maintain or improve your condition, complete three workouts each week, with at least one day of rest between workouts. After a few months of regular exercise, you may complete up to five workouts each week, if desired. Remember, the key to success is to make exercise a regular and enjoyable part of your everyday life.

PART LIST

Model No. 831.24833.0 R0811A

Key No.	Qty.	Description	Key No.	Qty.	Description
1	8	#8 x 1/2" Ground Screw	45	1	5/32" Hex Key
2	6	3/8" x 3 1/4" Screw	46	1	Right Rear Foot
3	10	3/8" Star Washer	47	1	Console Ground Wire
4	31	#8 x 3/4" Screw	48	1	Motor Hood
5	8	5/16" x 3/4" Screw	49	1	Incline Motor
6	8	5/16" Star Washer	50	2	Lift Frame Bushing
7	4	#8 x 1" Screw	51	1	Lift Frame
8	2	#10 x 1 1/2" Screw	52	1	Belly Pan
9	2	3/8" x 2 1/2" Bolt	53	1	Power Cord Grommet
10	1	Incline Motor Spacer	54	1	Power Cord
11	2	M6 x 50mm Screw	55	1	Power Switch
12	2	3/8" x 1" Bolt	56	4	1/4" x 3 1/2" Screw
13	3	Hood Clip	57	1	Console
14	19	#8 x 3/4" Truss Head Screw	58	1	Console Base
15	1	3/8" x 1 3/4" Bolt	59	1	Left Handrail
16	6	3/8" Jam Nut	60	2	Lower Handrail Cap
17	2	1/4" x 3/8" Screw	61	1	Console Crossbar
18	4	#8 x 1/2" Screw	62	1	Key/Clip
19	4	5/16" x 1 1/2" Bolt	63	1	Upright Wire
20	4	5/16" Nut	64	1	Right Handrail
21	2	Upper Handrail Cap	65	2	Upper Body Arm Insert
22	2	#8 Star Washer	66	1	Left Upright
23	4	1/4" Star Washer	67	1	Latch Housing
24	2	Drive Roller Washer	68	1	Latch Pin Assembly
25	2	1/4" x 1 1/4" Screw	69	2	Warning Decal
26	2	Incline Frame Washer	70	4	Base Cap
27	1	Left Foot Rail	71	2	Thick Base Pad
28	2	Platform Cushion	72	2	Thin Base Pad
29	1	Caution Decal	73	1	Upright Grommet
30	2	Belt Guide	74	1	Base
31	1	Drive Roller/Pulley	75	2	Wheel
32	1	Magnet	76	1	Right Upright
33	1	Reed Switch	77	2	Lift Frame Pin
34	1	Reed Switch Clamp	78	8	#8 x 3/4" Tek Screw
35	1	Drive Motor	79	2	1/4" Star Washer
36	1	Controller	80	1	3/8" x 1 1/2" Bolt
37	1	Controller Plate	81	2	Wire Tie
38	1	Frame	82	1	Latch Spacer
39	1	Walking Platform	83	2	Console Clamp
40	1	Walking Belt	84	1	Left Upper Body Arm
41	1	Right Foot Rail	85	1	Right Upper Body Arm
42	1	Idler Roller	86	2	#10 x 3/4" Screw
43	1	Left Rear Foot	87	8	#10 Flat Washer
44	1	Hex Key	*	-	User's Manual

Note: Specifications are subject to change without notice. For information about ordering replacement parts, see the back cover of this manual. *These parts are not illustrated.

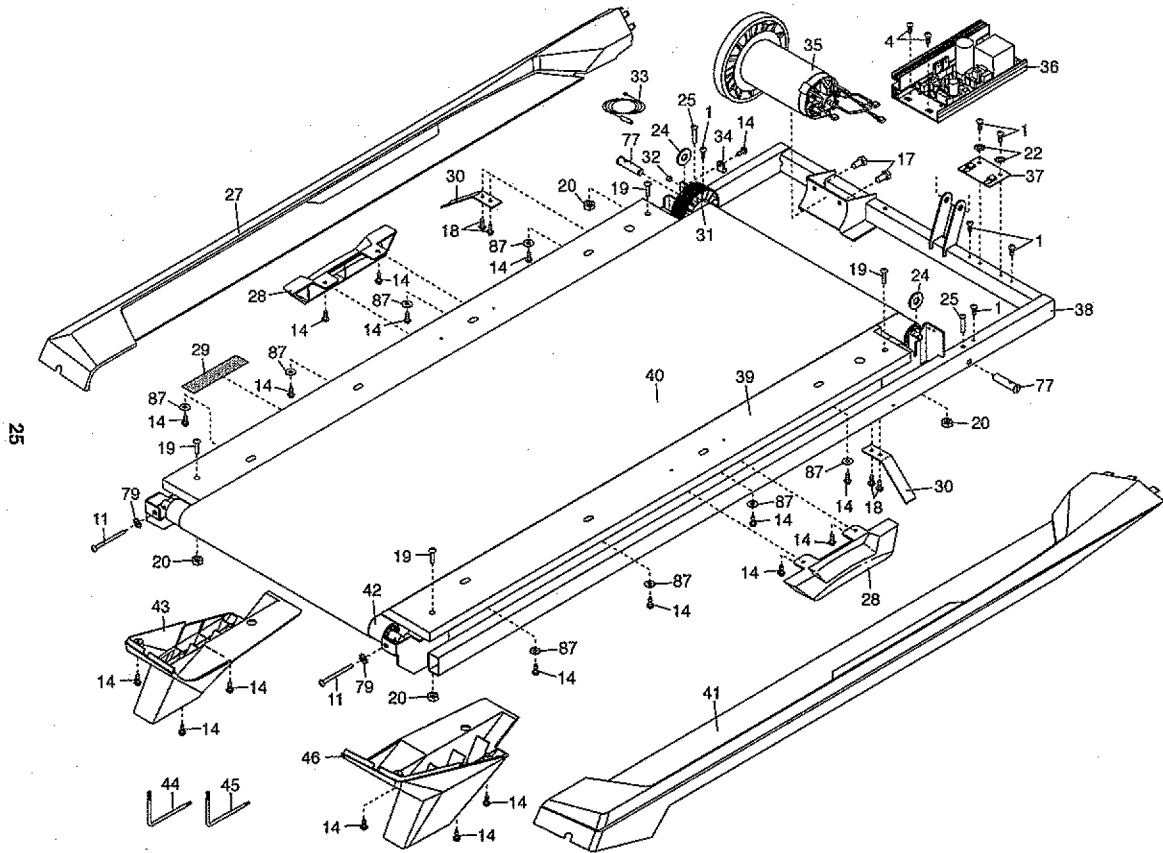

EXPLODED DRAWING A

Model / No. 831.24833.0 R0811A

EXPLODED DRAWING B

Model No. 831.24833.0 R0811A

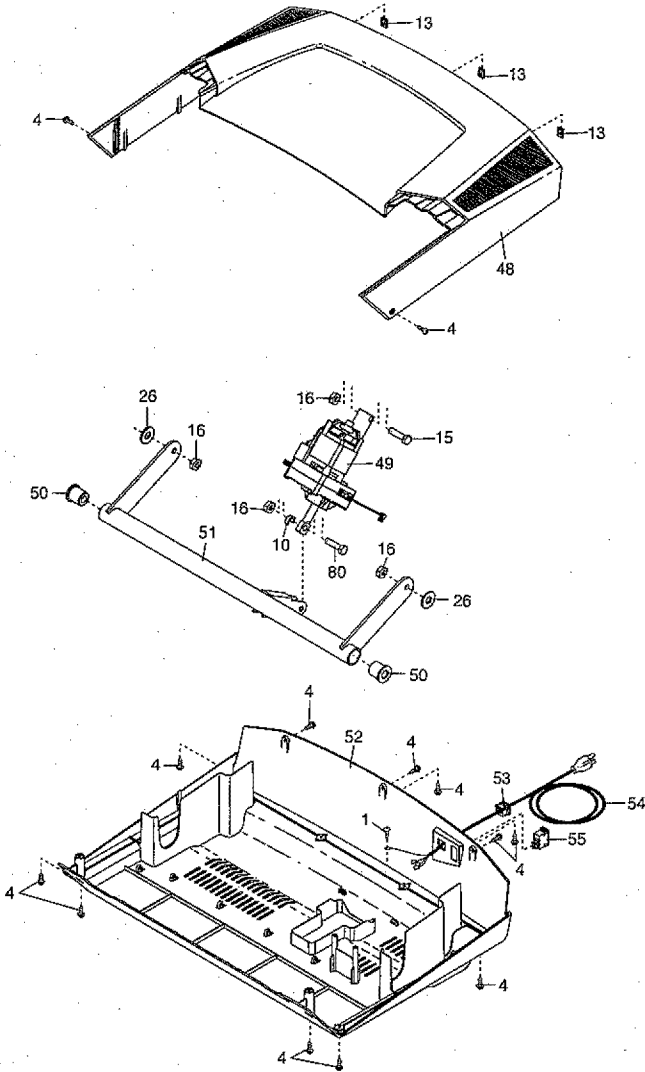

EXPLODED DRAWING C

Model No. 831.24833.0 R0811A

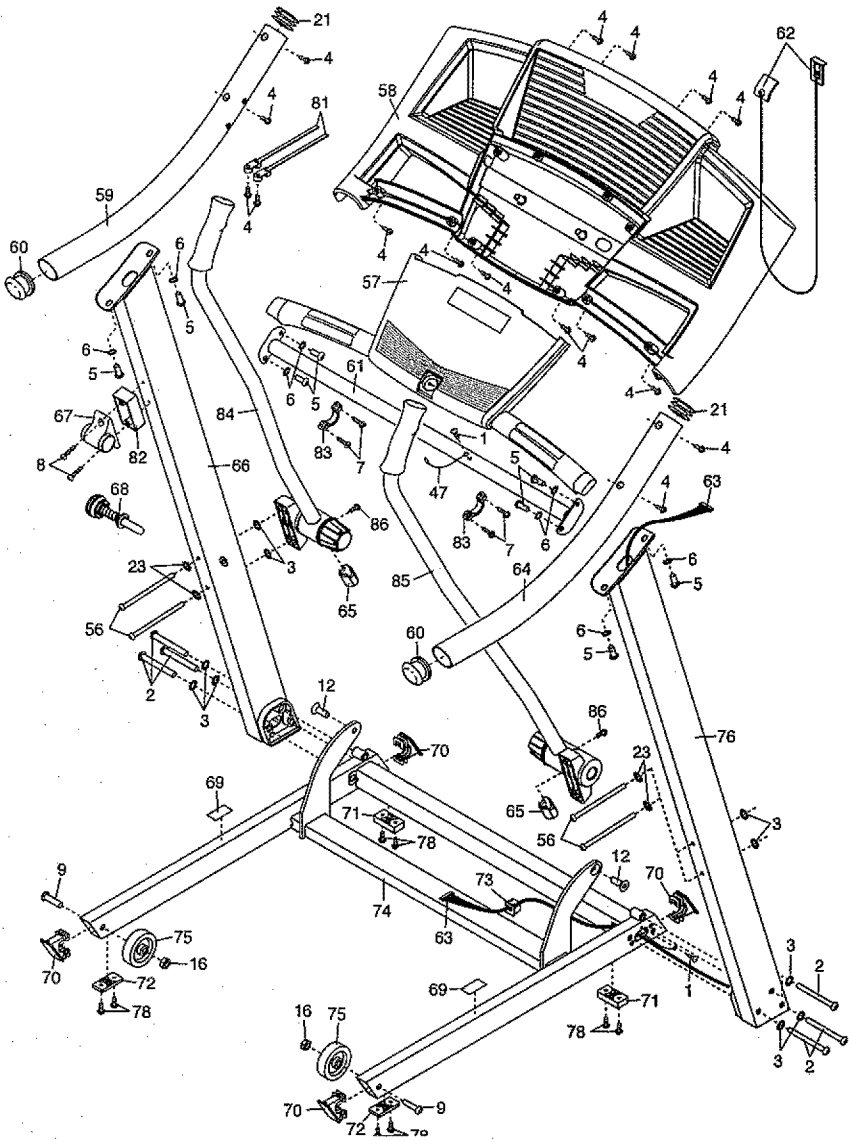

Get it fixed, at your home or ours!

Your Home

For repair—in your home—of all major brand appliances, lawn and garden equipment, or heating and cooling systems, **no matter who made it, no matter who sold it!**

For the replacement parts, accessories, and user's manuals that you need to do-it-yourself.

For Sears professional installation of home appliances and items like garage door openers and water heaters.

1-800-4-MY-HOME® (1-800-469-4663)

Call anytime, day or night (U.S.A. and Canada)

www.sears.com

www.sears.ca

Our Home

For repair of carry-in items like vacuums, lawn equipment, and electronics, call or go on-line for the location of your nearest **Sears Parts & Repair Center.**

1-800-488-1222 Call anytime, day or night (U.S.A. only)

www.sears.com

To purchase a protection agreement (U.S.A.) or maintenance agreement (Canada) on a product serviced by Sears:

1-800-827-6655 (U.S.A.)

1-800-361-6665 (Canada)

Para pedir servicio de reparación a domicilio, y para ordenar piezas:

1-888-SU-HOGAR® (1-888-784-6427)

Sears

® Registered Trademark / ™ Trademark / ™ Service Mark of Sears Brands, LLC
© Marca Registrada / ™ Marca de Fábrica / ™ Marca de Servicio de Sears Brands, LLC

90-DAY FULL WARRANTY

If this Sears Treadmill Exerciser fails due to a defect in material or workmanship within 90 days of the date of purchase, call 1-800-4-MY-HOME® (1-800-469-4663) to arrange for free repair (or replacement if repair proves impossible). The frame and drive motor are warranted for five (5) years from the date of purchase.

This warranty does not apply when the Treadmill Exerciser is used commercially or for rental purposes.

This warranty gives you specific legal rights, and you may also have other rights which vary from state to state.

Sears, Roebuck and Co., Hoffman Estates, IL 60179