

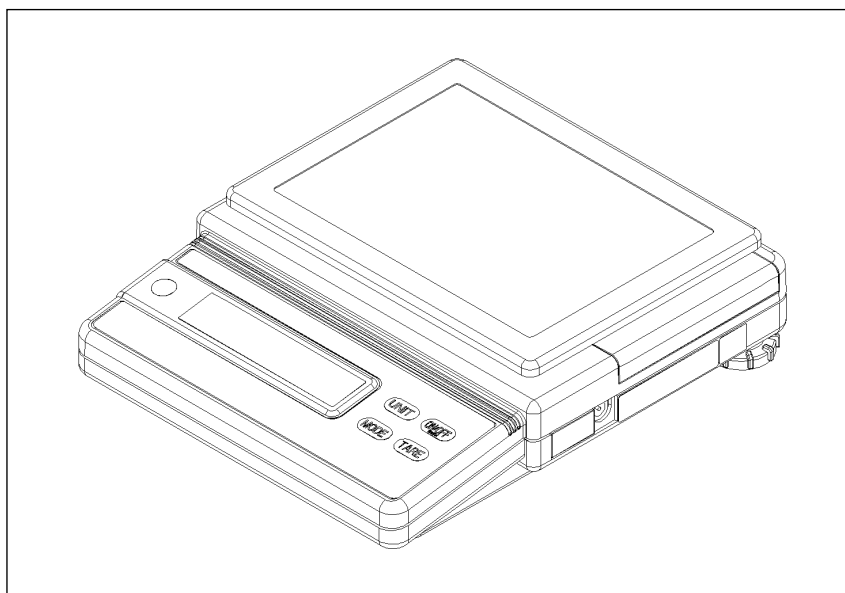

SHIMADZU ELECTRONIC BALANCE ELB SERIES

ELB120, ELB200, ELB300, ELB600,
ELB1200, ELB2000, ELB3000, ELB12K,
ELB600S, ELB600S

INSTRUCTION MANUAL



SHIMADZU CORPORATION
ANALYTICAL & MEASURING INSTRUMENTS DIVISION
KYOTO, JAPAN

**SHIMADZU ELECTRONIC BALANCE
ELB SERIES**

**ELB120, ELB200, ELB300, ELB600,
ELB1200, ELB2000, ELB3000, ELB12K,
ELB600S, ELB6000S**

INSTRUCTION MANUAL

Read this manual thoroughly to ensure correct use of the equipment. Save this for reference in use.

SHIMADZU CORPORATION
ANALYTICAL & MEASURING INSTRUMENTS DIVISION
KYOTO, JAPAN

Safety Precautions

NOTICE

Precautions in this instruction manual are defined as follows.

CAUTION! Failing to observe this may result in light to medium levels of injury or physical damage.

NOTICE Information for the correct use of the equipment.

Follow the cautions below for safe and proper use of the ELB balance.

CAUTION! Do not use the ELB balance in dangerous areas*.

Use only the AC adapter provided by the distributor authorized by Shimadzu if using an AC adapter.

Use options and peripherals provided by Shimadzu. Use of inadequate attachments and peripherals may cause malfunction of the balance.

The ELB balance is a precision instrument. Take enough care and precautions when handling it to ensure proper operation over a long period of time.

* Places exposed to flammable gases, liquids or dust.

Introduction

Thank you for purchasing the Shimadzu ELB Series Electronic Balance. Before using the balance, read this Instruction Manual carefully and store it for reference in use.

Contents

1. LIST OF COMPONENTS AND NAMES OF UNITS	1
2. FITTING & REPLACING THE DRY BATTERIES	4
3. INSTALLATION	5
4. CAUTIONS AND NOTICES	6
5. MEASUREMENT PROCEDURE	6
6. AUTO POWER OFF FUNCTION	8
6.1 SETTING THE AUTO POWER OFF FUNCTION	8
6.2 DISABLING THE AUTO POWER OFF FUNCTION	9
7. MENU SELECTION	10
8. REGISTRATION OF UNITS	12
8.1 CONDITIONS FOR REGISTRATION	12
8.2 REGISTRATION PROCEDURES	12
8.3 DELETING THE REGISTRATION	12
9. CALIBRATION	13
10. PIECE COUNTING	14
11. PERCENTAGE CONVERSION	16
12. SPECIFIC GRAVITY MEASUREMENT	17
13. SWITCHING UNITS	19
14. PERFORMANCE INSPECTION	20
15. MAINTENANCE	21
16. MALFUNCTION?	22
17. SPECIFICATIONS	23
18. PARTS LIST	25
19. SPECIAL ACCESSORIES (OPTIONS)	26
19.1 BELOW-BALANCE-WEIGHING HOOK	26
19.2 PERIPHERALS	27
19.2.1 PRINTER EP-60A	27
19.2.2 RS-232C INTERFACE IFB-102A	27
19.2.3 INPUT/OUTPUT FORMAT	28
19.2.4 COMMAND CODES	30

1. List of Components and Names of Units

List of components

The following components (one for each) are contained in the package.

Balance main unit (Dry battery holder and dry battery cover are fitted before shipment.)		
In-use keypad protective cover	Pan supporter	Pan
Instruction manual	Operating guide	

(Dry batteries are not packed.)

Names of units

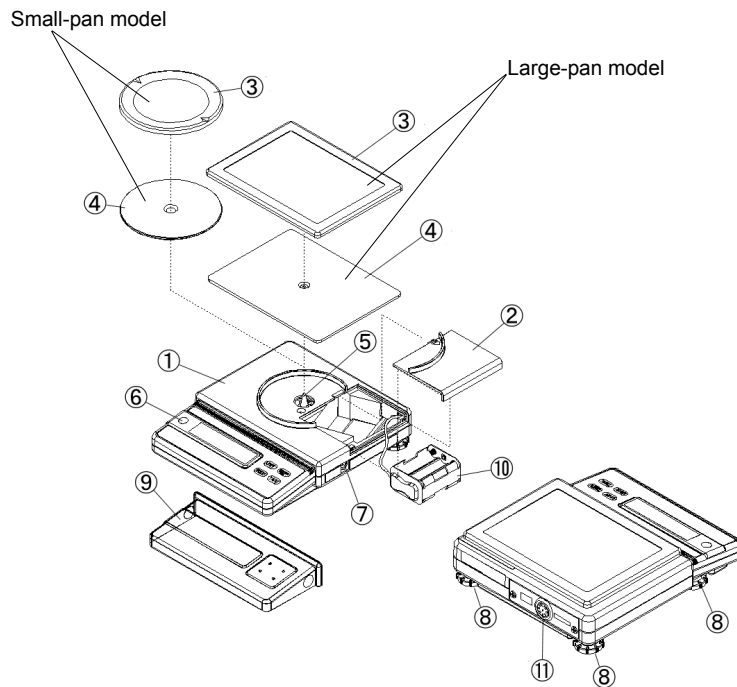

- | | | |
|---------------------------|----------------------------------|-------|
| ① Balance main unit | ② Dry battery cover | ③ Pan |
| ④ Pan supporter | ⑤ Pan supporter shaft | |
| ⑥ Level indicator | ⑦ Power jack | |
| ⑧ Level screws (3 places) | ⑨ In-use keypad protective cover | |
| ⑩ Dry battery holder | ⑪ DATA I/O connector | |

Key names and functions

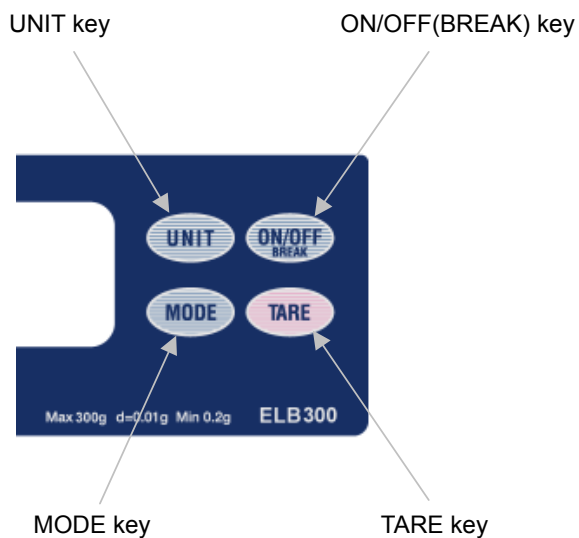

Name of Key	Function
ON/OFF(BREAK)	<ol style="list-style-type: none"> 1) Turns the power on/ off. 2) Discontinues menu selection. 3) Cancels the Auto Print function. 4) Stops continuous data output to external instruments.
TARE	<ol style="list-style-type: none"> 1) Subtracts the weight of the container. 2) Confirms menu selections. 3) Sets the reference values for piece counting and percentage conversion.
UNIT	<ol style="list-style-type: none"> 1) Switches the units. 2) Cancels the Auto Print function. 3) Stops continuous data output to external instruments.
MODE	<ol style="list-style-type: none"> 1) Selects different menu items. 2) Measures the weight in air during specific gravity measurement. 3) Cancels the Auto Print function. 4) Stops continuous data output to external instruments.

Display

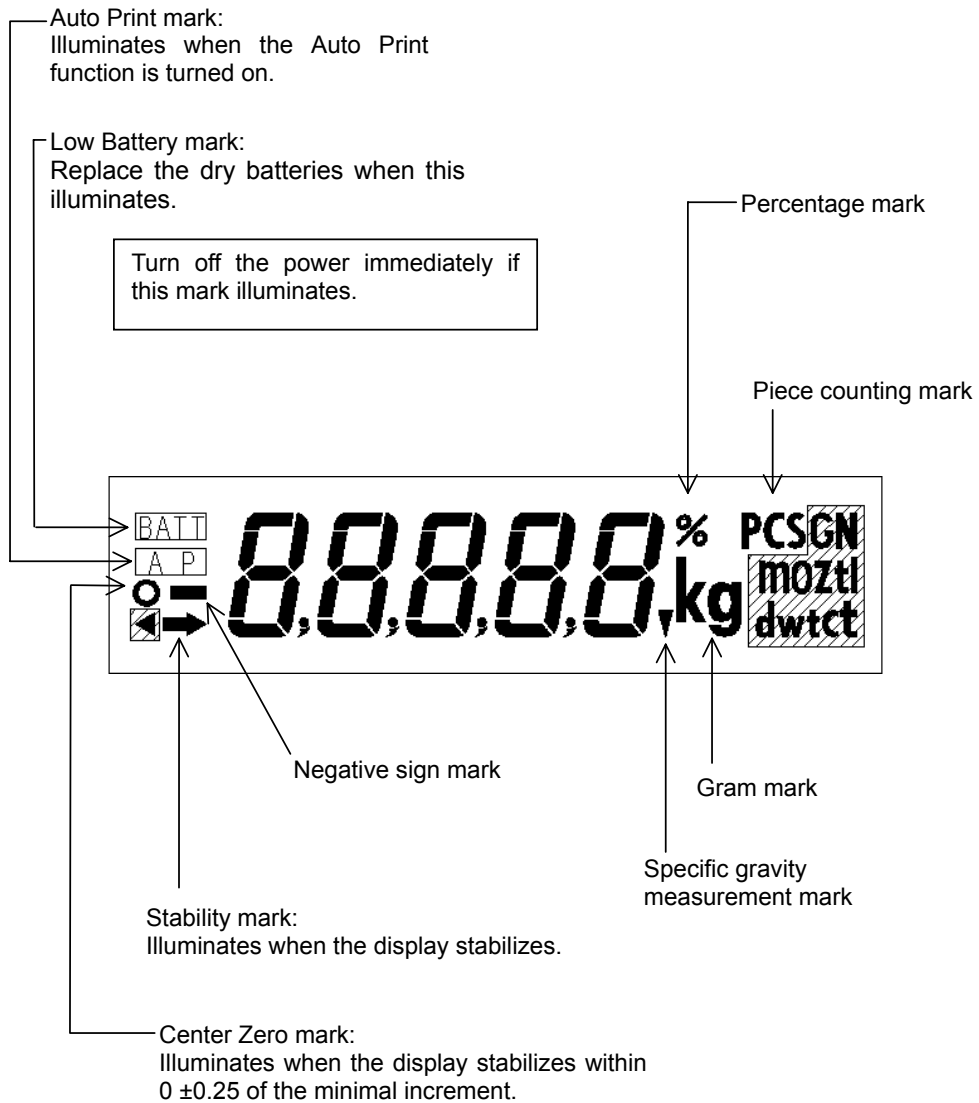

Not applicable depending on the local regulations for measuring instruments.

2. Fitting & Replacing the Dry Batteries

NOTICE

Always use six AA dry batteries.

The dry batteries are fitted or replaced according to the steps outlined below.

Fitting the dry batteries

- (1) Press down lightly on the  part of the dry battery cover and pull it in the indicated direction to remove it.

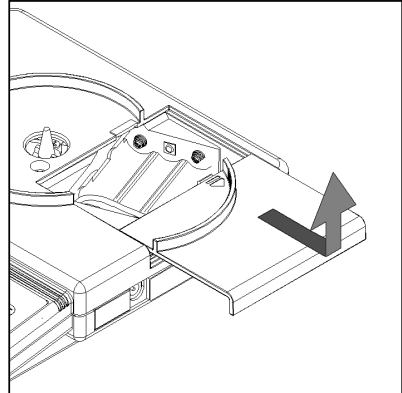

- (2) Take out the dry battery holder.

- (3) Fit six AA batteries in the dry battery holder.
When replacing the dry batteries, take the used dry batteries out of the holder.

CAUTION! Make sure that the polarities are correct when fitting the batteries.

CAUTION! Do not mix and use old dry batteries with new ones.

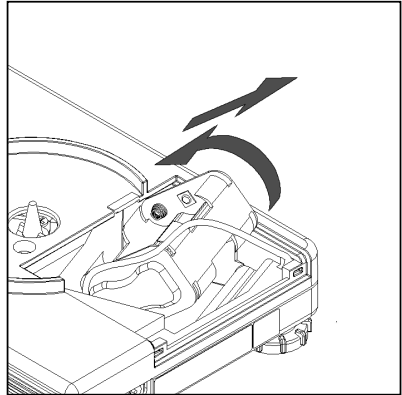

- (4) Put the dry battery holder back in place and fit the dry battery cover in the indicated direction.

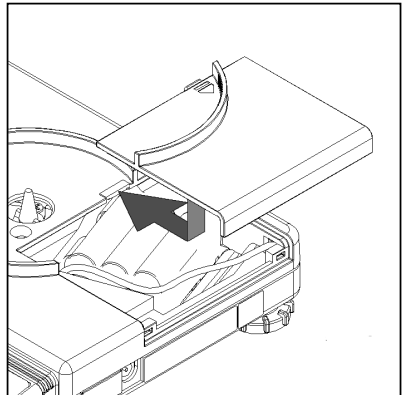

3. Installation

Power supply **NOTICE** The dry batteries are not included. In addition, the unit will operate off the dry batteries if the AC adaptor is connected.

Installation location Avoid the following conditions:
CAUTION! Exposure to corrosive or flammable gases.
NOTICE Exposure to dust, wind, vibrations, electromagnetic waves and magnetic fields.
NOTICE Exposure to direct sunlight, remarkable temperature fluctuations.
NOTICE Extremely high/low temperatures or high/low humidity.

- Installation
- (1) Remove the protection paper at 2 places on the in-use keypad protective cover and mount the cover over the keypad.
 - (2) Mount the pan supporter and the pan on the pan supporter shaft.

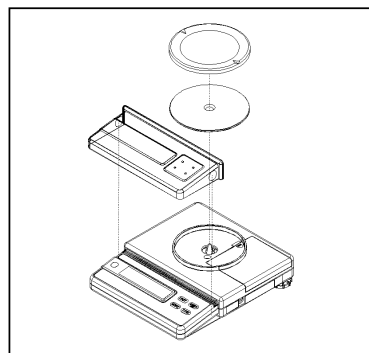

- (3) Assure the horizontal installation of the balance by rotating the level screw until the air bubble in the level comes to a rest in the center of the red circle. (Also check that the balance is placed steadily.)
For quick adjustment, screw in the back left level screw until it does not touch the table. Level the balance using the 2 screws at the rear. Finally, adjust the back left level screw so that it touches the table supporting the balance steadily.

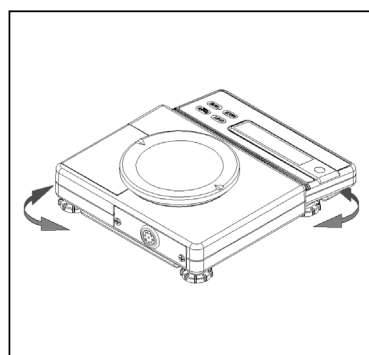

* Figures show small-pan model.

4. Cautions and Notices

Observe the following:

CAUTION! Use only the AC adaptor provided by the distributor authorized by Shimadzu if using an AC adaptor.

NOTICE Make sure that any foreign objects, including water and metal pieces, do not enter the interior of the balance.

NOTICE Do not leave the balance with objects on the pan.

NOTICE Do not cause a shock to the pan.

5. Measurement Procedure

The procedures are explained using the ELB300 as an example.

Turn on the power

- (1) Check that nothing is placed on the pan.
- (2) Press the [ON/OFF(BREAK)] key.
- (3) The Check display will illuminate, indicating that the temperature sensor inside the balance is being checked.

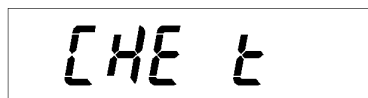

Depending on the ambient temperature, this may remain illuminating for about 30 seconds.

- (4) The all segments illuminate for approximately 6 seconds.

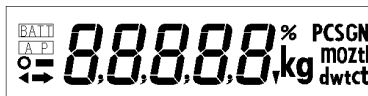

- (5) Zero is displayed.
The zero may be unstable immediately after the power is turned on. Allow the balance to warm up for more than 5 minutes. To conduct accurate measurements, a warm up time of over 30 minutes is recommended.

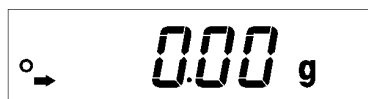

- (6) Calibrate sensitivity (refer to "9. Calibration").

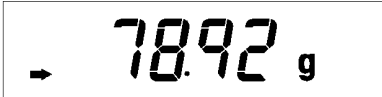
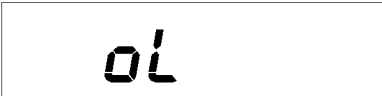
- Measurement (1) Place the container* on the center of the pan and press the [TARE] key.
Check that the Center Zero mark illuminates.
- 
- (2) Load the sample and read the displayed value when the display stabilizes.
To conduct accurate measurements, perform a preliminary loading* before conducting measurements.
“oL” will be displayed if the weight of the sample exceeds the capacity, or the combined weight of the sample and container exceeds the total available range of the balance.
- 
- 
- (3) Dry Batteries consumption can be reduced by activating the Auto Power Off function.
Refer to “6. Auto Power Off Function” for information on how to set and disable the Auto Power Off function.

*Container: Any container in which the sample is placed. Measurements without any container are also possible.

*Preliminary loading: “Preliminary loading” refers to loading and unloading the sample or the weight once before conducting the actual measurement. A preliminary loading improves the accuracy of the measurement.

Turn off the power Press the [ON/OFF(BREAK)] key during weight display.

⚠ CAUTION! Be sure to turn off the power when the balance is not to be used for a long period of time.

6. Auto Power Off Function

The power is automatically cut when the balance is left unused* for about 5 minutes or more. Effective usage of this function can reduce dry batteries consumption.

*The balance is considered to be unused when the following conditions (1) and (2) continue.

- (1) Keys are not operated.
- (2) No changes in the measured weight value amounting to “approx. 1g or more over a 0.5 second period” are detected.

NOTICE This function is activated at the time of factory shipment.

6.1 Setting the Auto Power Off Function

- (1) Press the [MODE] key 5 times from weight display.
- (2) The display shown on the right will appear.
- (3) Press the [TARE] key.
- (4) The balance will revert to weight display after the display on the right is shown.

A rectangular digital display showing the text "P.O.-on" in a black, monospaced font.

A rectangular digital display showing the text "SET" in a black, monospaced font.

CAUTION! The internal values of the balance are being revised while “SET” is displayed. Never turn off the power while “SET” is displayed.

- (5) When the Power Off function is activated, the display will begin to flash approx. 10 seconds before the power is about to be cut.

The display will stop flashing if either the keys are operated or an item of about 1g or more is weighed, in which case the balance will return to normal weighing mode.

A rectangular digital display showing "0.00 g" in a black, monospaced font. The display has a dashed border and tick marks on the top and bottom edges.

6.2 Disabling the Auto Power Off function

(1) Press the [MODE] key 6 times.

A rectangular box containing the text "P.L.-oF" in a stylized, digital font.

(2) The display shown on the right will appear.

(3) Press the [TARE] key.

(4) After the display shown on the right appears,
the balance will revert to weight display.

A rectangular box containing the text "SEt" in a stylized, digital font.

⚠ CAUTION! The internal values of the balance are being revised while "SEt" is displayed. Never turn off the power while "SEt" is displayed.

7. Menu Selection

Various functions, including selecting different measurement speeds and setting of the piece counting mode, are available on the ELB-series balance. Selection of these functions is referred to as “Menu Selection”.

- Procedure
- (1) Press the [MODE] key.
 - (2) The currently set conditions are displayed in symbols.
(Example)

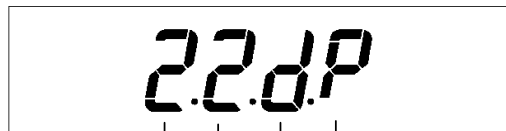

Auto Power Off function activated *
 Zero tracking activated *
 Stability detection width: Large
 Normal Response Mode
 (Items with “*” illuminates when set to on.)

- (3) The display changes in the order shown in the table on page 11 by pressing the [MODE] key.
- (4) To select a condition or a mode, press the [TARE] key while the condition or the mode is displayed.

When a condition or a mode is selected, “SEt” is displayed, and then it reverts to the weight display. (This does not occur when calibration, piece counting, or percentage conversion is selected.)

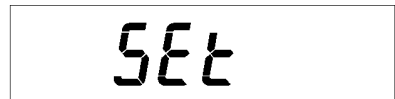

⚠ CAUTION! The internal values of the balance are being revised while “SEt” is displayed. Do not turn off the power while “SEt” is displayed.

- (5) After displaying “SG” (“Unit kg” for the ELB12K), the balance reverts to the weight display.
 - Press the [ON/OFF(BREAK)] key to stop menu selection.
 - Set the response mode to “Normal” (A-2) in ordinary cases.
 Set the response mode to “Fast” (A-1) when it is necessary to reduce the time required for measurements. (Be acknowledged that measurement accuracy may be sacrificed).

- Set the internal stability detection width to "Large" (**P-2**) when external causes such as vibration hinder smooth output for Auto Printing, or when intending to reduce the time required for output. (Be acknowledged that measurement accuracy may be sacrificed.)
- Activating Zero Tracking (**d-on**) will automatically cancel the minor fluctuation in the zero display. Select "**d-off**" when measuring slight differences of the weight.

Menu Items

	Display	Description	Symbol for conditions display
Mode	Conv PCS	Piece counting	
	Conv %	Percentage conversion	
	CAL	Calibration	
Conditions	P.C.-on	Auto Power Off function activated	P
	P.C.-oF	Auto Power Off function disabled	
	A-1	Fast Response Mode	1
	A-2	Normal Response Mode	2
	P-1	Internal stability detection width: Small	1
	P-2	Internal stability detection width: Large	2
	d-on	Zero tracking: ON	d
	d-off	Zero tracking: OFF	
IF	RS-232C communication specification settings		
Mode	SG	Specific gravity measurement	
Units	* ¹ Unit kg	Kilogram	
	Unit g	Gram	
	Unit ct	Carat	1ct=0.2g
	* ² Unit oz	Ounce	1oz=28.3495g
	* ² Unit ozt	Troy ounce	1ozt=31.1035g
	* ² Unit dwt	Penny weight	1dwt=1.55517g
	* ² Unit GN	Grain	1GN=0.0647989g
	* ² UnitH tl	Hong Kong tael	1tl=37.429g
	* ² UnitS tl	Singapore tael	1tl=37.7994g
	* ² Unitt tl	Taiwan tale	1tl=37.5g
	* ² Unit mo	Momme	1mo=3.75g
CLEAR	Canceling registered units		

*¹ELB12K only

*²Not applicable depending on the local regulations for measuring instruments.

8. Registration of Units

Three units can be registered in addition to “gram”. The registered units remain after the power has been turned off. Registered units can be selected by pressing the [UNIT] key.

8.1 Conditions for Registration

- Up to three units (including piece counting, % and specific gravity) can be registered in addition to “gram”.
- When a new unit is added after three units have been registered, the first-registered unit is deleted and the new unit is added.

8.2 Registration Procedures

- 1) Repeat pressing the [MODE] key while the balance displays the weight (except for the case of specific gravity measurement) until “Unit xx” is displayed.
- 2) Press the [TARE] key when the desired unit is displayed. “→” is displayed for already registered units.
- 3) “SEt” appears on the display and it changes to the weight display with the newly registered unit.

⚠ CAUTION! The internal values of the balance are being revised while “SEt” is displayed. Do not turn off the power while “SEt” is displayed.

8.3 Deleting the Registration

- Follow the procedure below to delete registered units one by one. (Piece counting and % cannot be deleted by this method.)

- 1) Repeat pressing the [MODE] key while the balance displays the weight (except for the case of specific gravity measurement) until “Unit xx” is displayed.
- 2) Repeat pressing the [MODE] key until the unit to delete is displayed. “→” is displayed for already registered units.
- 3) Press the [TARE] key when the unit to delete is displayed.
- 4) “SEt” appears on the display and it changes to the weight display.

⚠ CAUTION! The internal values of the balance are being revised while “SEt” is displayed. Do not turn off the power while “SEt” is displayed.

- Follow the procedure below to delete all the units registered.

- 1) Repeat pressing the [MODE] key while the balance displays the weight (except for the case of specific gravity measurement) until “CLEAR” is displayed.
- 2) Press the [TARE] key while “CLEAR” is displayed.
- 3) “SEt” appears on the display and it changes to the weight display.

⚠ CAUTION! The internal values of the balance are being revised while “SEt” is displayed. Do not turn off the power while “SEt” is displayed.

9. Calibrationz

The ELB-series electronic balance measures the weight using the gravity of the earth. Since the acceleration due to gravity varies slightly from region to region, the sensitivity must be calibrated when the balance is installed. Perform sensitivity calibration also in the following cases: (1) when there was a large fluctuation in room temperature, (2) before conducting measurements requiring a high degree of accuracy, (3) when moving the balance from one place to another, and (4) as periodical maintenance once a month.

- | | | | |
|-----------|-----|--|--|
| Procedure | (1) | With nothing on the pan, go through the menu selections to display “CAL” for calibration. (Refer to “7. Menu Selection”.)
Press the [TARE] key. | |
| | (2) | The value of the weight to be used for calibration flashes on the display. | |
| | (3) | Place the calibration weight on the pan. (Refer to “17. Specifications” for information on the calibration weight.) | |
| | (4) | Press the [TARE] key when the stability mark illuminates. | |
| | (5) | Zero flashes on the display. | |
| | (6) | Remove the weight from the pan and press the [TARE] key when the stability mark is displayed. | |
| | (7) | “End” appears on the display and it reverts to the weight display. | |

⚠ CAUTION! The internal values of the balance are being revised while “End” is displayed. Do not turn off the power while “End” is displayed.

- “C E4” is displayed if an improper weight is placed on the pan, disabling calibration.

- Press the [ON/OFF(BREAK)] key to abort calibration. "Abort" is displayed and then the balance reverts to the weight display.

Aborting is not possible while "End" is being displayed.



10. Piece Counting

The ELB-series balance is capable of counting the number of pieces of the sample by measuring the weight of a single piece of the sample.

The number of pieces to determine the weight of the single piece can be selected from 10, 20, 50 and 100 (the larger the number of pieces, the higher the measurement accuracy). The counted number of pieces is displayed with the unit "PCS".

Setting procedure

- (1) Place the container on the pan and press the [TARE] key.



- (2) Select piece counting mode (Conv PCS) in menu selection, and press the [TARE] key. (Refer to "5. Menu Selection".)



- (3) The number of reference pieces "10" is displayed. Select the intended number by pressing the [MODE] key. The displayed number changes in the following order: 10 -> 20-> 50 -> 100 -> 10...

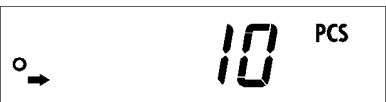

- (4) Place the displayed number of sample pieces in the container while the number of reference pieces is displayed.

- (5) Press the [TARE] key when the stability mark illuminates.

- (6) After "Set" is displayed, it changes to the piece counting display with the "PCS" mark illuminating.



At the same time, the reference weight and the “PCS” unit are registered on the [UNIT] key. (Refer to “13. Switching Units”).

⚠ CAUTION! The internal values of the balance are being revised while “SEt” is displayed. Do not turn off the power while “SEt” is displayed.

- If the sample weight exceeds the capacity of the balance, or the weight of a piece of the sample is smaller than the minimum increment, “r E4” is displayed and the display reverts to the unit before menu selection.

A rectangular box containing a digital display showing the characters "r E4" in a stylized, segmented font.

- Press the [ON/OFF(BREAK)] key to abort piece counting settings. “Abort” is displayed and then it reverts to the display before menu selection.

A rectangular box containing a digital display showing the word "Abort" in a stylized, segmented font.

Aborting is not possible while “SEt” is being displayed.

11. Percentage Conversion

The ELB-series balance is capable of calculating and displaying the sample percentage to the reference set as 100%.

Setting procedure

- (1) Place the container on the pan and press the [TARE] key.



- (2) Select percentage conversion mode (**Conv %**) in menu selection, and press the [TARE] key. (Refer to "7. Menu Selection".)



- (3) "100%" is displayed.



- (4) Place the sample to be used as reference in the container.



- (5) Press the [TARE] key when the stability mark illuminates.



- (6) After "SEt" is displayed, it changes to the percentage display with the "%" mark illuminating.

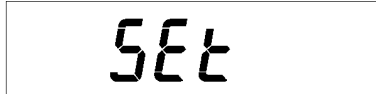

At the same time, the reference weight and the "%" unit are registered on the [UNIT] key. (Refer to "13. Switching Units")

⚠ CAUTION! The internal values of the balance are being revised while "SEt" is displayed. Do not turn off the power while "SEt" is displayed.

- If the sample weight exceeds the capacity of the balance, or it is smaller than 100 times the minimum increment, "r E4" is displayed and the display reverts to the unit before menu selection.



- Press the [ON/OFF(BREAK)] key to



abort piece counting settings. “**Abort**” is displayed and then it reverts to the display before menu selection.

Aborting is not possible while “**SEt**” is being displayed.

- % will be displayed with the following number of digits depending on the weight of the reference sample.

Less than 1000 times the minimum increment	No decimals
Less than 10000 times the minimum increment	To the 1 st decimal place
More than 10000 times the minimum increment	To the 2 nd decimal place

12. Specific Gravity Measurement

The ELB-series balance allows easy measurements of the specific gravity of a sample by measuring its weight in air and in water (with the specific gravity of water taken to be one).

The optional below-balance-weighing hook facilitates the measurement in water. Described below is the procedure when using the below-balance-weighing hook. (See “19.1 Below-Balance-Weighing Hook”.)

The optional “Specific Gravity Measurement Set” is also available.

The weight in air during specific gravity measurement is displayed as grams.

Procedure (1) Select specific gravity measurement mode (**SG**) in menu selection. (Refer to “7. Menu Selection”.)



(2) Press the [TARE] key. “**SEt**” is displayed and then “g” and the specific gravity measurement mark (▼) illuminate.



⚠ CAUTION! The internal values of the balance are being revised while “**SEt**” is displayed. Do not turn off the power while “**SEt**” is displayed.

(3) Press the [TARE] key when there is no sample on the pan to zero the display.



- (4) Place the sample on the pan to measure its weight in air.

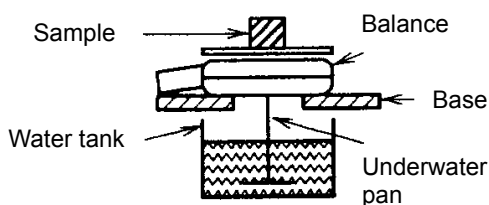

- (5) Press the [MODE] key when the display has stabilized.

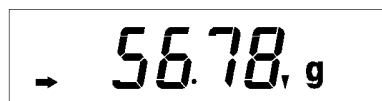

- (6) The gram mark disappears with the specific gravity measurement mark remaining illuminating and displaying the specific gravity value.
(The display fluctuates. However, this is not a problem.)

- (7) Unload the sample and place the sample on the underwater pan.

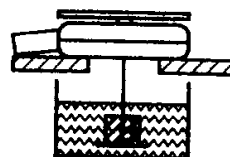

- (8) Read the displayed value when the stability mark illuminates.

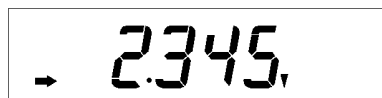

- The weight in air has to be more than 100 times the minimum increment to ensure accurate measurements.

- (9) Press the [UNIT] key to revert to the gram display.

- "-OL" is displayed if the calculation results are negative.
- The calculation results can be output by the print command while the results are being displayed. (Continuous output is not possible during specific gravity measurement.)
- Return to step (3) by pressing the [MODE] key to continue specific gravity measurements.
- The specific gravity is calculated using the following equation.

$$\frac{\text{(Weight in Air)}}{\text{(Weight in Air) - (Weight in Water)}}$$

- To stop specific gravity measurement and revert to weight measurement...

(a) while displaying specific gravity value: press the [MODE] key and then press the [UNIT] key.

(b) while displaying weight in specific gravity mode (while displaying “▼ g”): press the [UNIT] key.

- The specific gravity measurement is registered for the [UNIT] key. Specific gravity measurement can be started from step (3) by pressing the [UNIT] key during weight measurement.

(10) To cancel specific gravity measurement, follow the procedure below.

- Press the [UNIT] key to display another unit (g, PCS, or %).
- Press the [MODE] key to display “SG”.
- The stability mark illuminates if specific gravity measurement has been set.
- Press the [TARE] key.

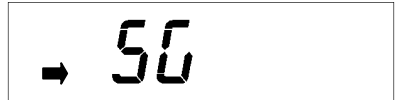

This cancels the specific gravity measurement, and the balance displays ordinary units such as g, PCS and %.

13. Switching Units

- Pressing the [UNIT] key switches the unit between “g” and other registered units. (The balance may be shipped from the factory with no units registered. In this case, the unit cannot be switched.)
- When piece counting or percentage conversion is registered for the [UNIT] key, the value will be calculated and displayed using the latest reference.
- The registered units remain after the power is turned off. The unit registered most recently appears on the display when the power is turned on.
- Three units can be registered in addition to grams.

14. Performance Inspection

Conduct performance inspection in a room at a temperature of approximately 25°C without large fluctuation. Perform this inspection as a guide to judge the proper operation of the balance.

Preparation	<ul style="list-style-type: none"> - Warm up the balance for more than 30 minutes after turning on the power. - The inspection should be conducted with the gram display. If another unit is displayed, press the [UNIT] key to switch to the gram display. - Select the following conditions in menu selection. <ul style="list-style-type: none"> Response mode A-2 (Normal) Internal stability detection width P-1 or P-2 Zero tracking d-oFF (off) - Perform preliminarily loading, and then press the [TARE] key to zero the display.
Repeatability	<p>(1) Repeat loading and unloading a weight close to the capacity 10 times and record the following values.</p> <p style="padding-left: 20px;">Xi: the value at which the display stabilizes after loading</p> <p style="padding-left: 20px;">Yi: the value at which the display stabilizes after unloading</p> <p>(2) Obtain the standard deviation σ_x and σ_y using the equation below.</p> $\sigma_x = \sqrt{\frac{\sum_{i=1}^{10} (Xi - \bar{Xi})^2}{9}}$ $\sigma_y = \sqrt{\frac{\sum_{i=1}^{10} (Yi - \bar{Yi})^2}{9}}$ <p>(3) Both σ_x and σ_y should be within 1.5 times the standard deviation indicated in “17. Specifications”.</p>
Cornerload error	<p>(1) Load a weight of approximately 1/4th the weighing capacity in the order of the numbers in the diagram below and record the values X1 to X5.</p> <p>(2) The differences between the value at the center of the pan (X1) and other values (X2 to X5) should be within 3 times the minimum increment.</p>

In the case of a square pan

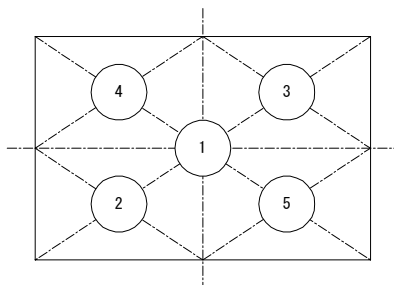

In the case of a round pan

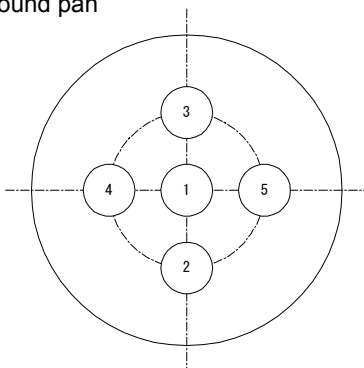

15. Maintenance

NOTICE Wipe any dirt away with a soft cloth moistened with a neutral detergent.

NOTICE Organic solvents and chemical dusters will damage the coating and membrane panel.

NOTICE Use the protective cover (supplied as a standard accessory or as an optional accessory) when using the balance in places where dirt may attach.

NOTICE The pan can be washed in water. Be sure that it is completely dry when using.

16. Malfunction?

Check the following items before contacting our service personnel.

When?	Phenomenon	Cause and Solution
Before measurement	- Nothing is displayed after the power is turned on.	-Dry batteries have not been fitted. -Dry batteries are drained. ➔ See “2. Fitting & Replacing the Dry Battery” and either fit the dry batteries or replace with new ones.
	- Stops at “CHE t”.	- Depending on the ambient temperature, “CHE t” may be displayed for about 1 minute. If “CHE t” remains displayed for more than 1 minute, contact our service personnel.
During measurement	- “OL” is displayed.	- An object heavier than the capacity has been placed on the pan. - Sensitivity (span) is not correct. ➔ See “9. Calibration”.
	- “-OL” is displayed.	- The pan and/or pan supporter is not mounted correctly.
	- The display fluctuates.	- Affection of vibration or wind. ➔ Install the balance at a place without vibration or wind. ➔ Set the response speed to normal. - Affection of electromagnetic waves or electrical noise. ➔ Place the balance away from the noise source.
	- The Low Battery mark remains illuminated.	-Dry batteries are empty. ➔ See “2. Fitting & Replacing the Dry Battery”.
	- The display goes off.	-Dry batteries have not been fitted. -Dry batteries are drained. ➔ See “2. Fitting & Replacing the Dry Battery” and either fit the dry batteries or replace with new ones. -The Auto Power Off function was activated. ➔ See “6. Auto Power Off Function”.
During piece counting	- Number of pieces cannot be counted correctly.	- There is a large variation in the weight between pieces of the sample. ➔ Increase the number of the reference sample pieces.
During specific gravity measurement	- The specific gravity value fluctuates.	- The weight of the sample is too small for the specific gravity.

If the following codes display during operation, solve the problem by applying the solution below.

Code	Description	Solution
C E4	This appears when an improper weight is placed on the pan during calibration.	Restart calibration with the correct weight.
C E2	This appears when trying to start calibration with an object on the pan.	Restart calibration after removing the object from the pan.
r E4	This appears when the reference value is smaller than the minimum increment in piece counting or percentage conversion mode.	Reset the reference with a larger amount of sample.
Err 1	Internal temperature sensor error.	Stop using the balance and contact our service personnel.
Err 4	Internal computation error.	

17. Specifications

Model	ELB120	ELB200	ELB300	ELB600	ELB1200
Weighing capacity	120g	200g	300g	600g	1200g
Minimum display	0.01g	0.01g	0.01g	0.05g	0.1g
Standard deviation	$\sigma \leq 0.01g$	$\sigma \leq 0.01g$	$\sigma \leq 0.01g$	$\sigma \leq 0.05g$	$\sigma \leq 0.1g$
Linearity errors	$\pm 0.01g$	$\pm 0.01g$	$\pm 0.02g$	$\pm 0.05g$	$\pm 0.1g$
Calibration weight	100g	200g	300g	500g	1000g
Pan size (mm)	$\phi 110$			170x130	
Stability of Sensitivity (5 to 35°C)	$\pm 20ppm/^{\circ}C$	$\pm 15ppm/^{\circ}C$	$\pm 10ppm/^{\circ}C$	$\pm 20ppm/^{\circ}C$	$\pm 20ppm/^{\circ}C$
Dimensions of main body (mm)	Approx. 185(W) x 215(D) x 55(H)				
Weight (kg)	Approx. 1.25				
Temperature range	5 to 40°C				
Power supply	6 x AA dry batteries 9DCV (1.5DCV x 6)				
Continuous operation time	Approx. 40 hours (using alkaline dry batteries)				
AC adapter (Option)	DC output voltage: 9 DCV DC output current: 80mA Shape of the plug:				
	<p style="text-align: center;"> 9.5mm or longer $2.1\text{mm}\phi$ $5.5\text{mm}\phi$ </p>				

Model	ELB2000	ELB3000	ELB12K	ELB600S	ELB6000S
Weighing capacity	2000g	3000g	12kg	600g	6000g
Minimum display	0.1g	0.1g	1g	0.1g	1g
Standard deviation	$\sigma \leq 0.1g$	$\sigma \leq 0.1g$	$\sigma \leq 1g$	$\sigma \leq 0.1g$	$\sigma \leq 1g$
Linearity errors	$\pm 0.1g$	$\pm 0.2g$	$\pm 1g$	$\pm 0.1g$	$\pm 1g$
Calibration weight	2000g	3000g	10kg	500g	5000g
Pan size (mm)	170 x 130				
Stability of Sensitivity (5 to 35°C)	$\pm 15ppm/^{\circ}C$	$\pm 10ppm/^{\circ}C$	$\pm 20ppm/^{\circ}C$	$\pm 20ppm/^{\circ}C$	$\pm 20ppm/^{\circ}C$
Dimensions of main body (mm)	Approx. 185(W) x 215(D) x 55(H)				
Weight (kg)	Approx. 1.25				
Temperature range	5 to 40°C				
Power	6 x AA dry batteries 9DCV (1.5DCV x 6)				
Continuous operation time	Approx. 40 hours (using alkaline dry batteries)				
AC adapter (Option)	DC output voltage: 9 DCV DC output current: 80mA Shape of the plug:				

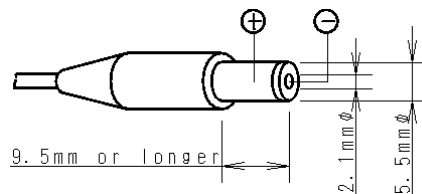

18. Parts List

Special Accessories (Options)

Product Name	P/N	Remarks
Below-weigh hook	321-34532-03	Cannot be used with the ELB12K.
Specific gravity measurement kit SMK-201	321-42253	Use with a balance whose capacity is 600g or more (the measurable weight is reduced by 200g). This set allows specific gravity measurement of samples with a volume of 5 to 500cm ³ (the size of the sample must be smaller than 115mm in diameter x 70mm in height).
Calibration weight	100g 321-53445-10 200g 321-53446-10 500g 321-53447-10 1kg 321-53448-10 2kg 321-53449-10 5kg 321-53450-10 10kg 321-53451-10	
Electronic Printer, EP-60A	321-42008-10	Thermal print
RS-232C interface, IFB-102A	321-41167-10	
Carrying case	321-50136	

Maintenance Parts

Item	P/N	Remarks
Square pan	321-41419	For large-pan model
Pan supporter, square	321-41394-90	For large-pan model
Round pan	321-41418-10	For small-pan model
Pan supporter, round	321-40910-90	For small-pan model
In-use protective cover	321-41617-01 321-41617-70	1 piece Contains 10 pieces
In-use keypad protective cover	321-62243	1 piece
Level adjusting feet	321-53530-30	
Rubber feet	321-33634-02	
Dry battery cover	321-62247-51	
Dry battery holder	321-61994-02	

19. Special Accessories (Options)

19.1 Below-Balance-Weighing Hook

With the below-balance-weighing hook, the sample can be suspended below the balance for weighing. This is particularly useful for specific gravity measurements.

Attaching the hook
to the balance

- (1) Turn off the power.
- (2) Remove the pan and pan supporter.
- (3) Remove the seal on the back of the balance.
- (4) **⚠ CAUTION!** While holding down the pan supporter shaft, screw the hook into the screw hole on the bottom of the balance by hand. (Do not use any tools such as a monkey wrench to tighten the hook, as it may damage the sensor inside the balance.)
- (5) Place the balance at a place where no excess force is applied to the hook.
- (6) Remount the pan supporter and pan onto the pan supporter shaft.

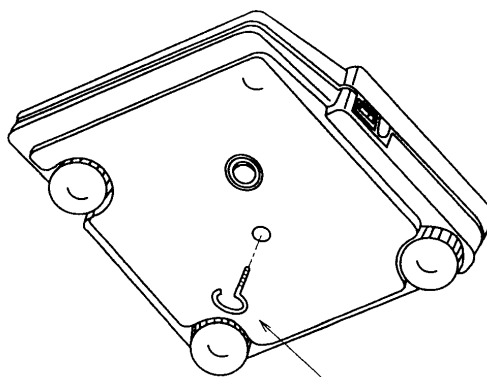

Below-balance-weighing hook

19.2 Peripherals

19.2.1 Printer EP-60A

The EP-60A is a thermal printer connected to the DATA I/O connector of the balance. The EP-60A prints the data displayed on the balance and performs statistical calculations.

See the instruction manual for the EP-60A for detailed information.

Before using the EP-60A, set the baud rate to 1200bps and stop bit to 1. (See “Selecting the Baud Rate” and “Selecting the Stop Bit” on page 27.)

19.2.2 RS-232C Interface IFB-102A

The IFB-102A is used to connect the balance to external devices such as a personal computer.

Connection | After confirming that the power of the balance has been turned off, insert the plug of the IFB-102A into the DATA I/O connector of the balance.

Signals

Pin No.	Signal Name	I/O	Description
1	FG		Ground
2	TXD	Out	Data output
3	RXD	In	Data input
4	RTS		Short circuit
5	CTS		
6	DSR	In	Communication possible with polarity (+)
7	SG		
20	DTR	Out	Communication impossible with polarity (-)

19.2.3 Input/Output Format

Key: "Δ" indicates a space and (CR) indicates a carriage return.

Input data | Command code + (CR) -> See "19.2.4 Command Codes".

Output data

- When displaying the weight

S - ΔΔ 300.00 gΔ (CR)

Unit + space

Space, number, decimal point

Polarity Positive space (Δ)
 Negative minus (-)

Internal stability
(when outputting with stability information)

 Stable S
 Unstable U

- When "oL" or "-oL" is displayed

S - ΔΔΔΔ oL ΔΔΔΔ (CR)

Unit + space

Polarity Positive space (Δ)
 Negative minus (-)

Internal stability
(when outputting with stability information)

 Stable S
 Unstable U

Data format

- ASCII (JIS) code

- Baud rate Select from 300, 600, 1200, 2400, 4800, and 9600.

- Parity Select from "EvEn" (even number), "odd" (odd number), and "non" (none).

- Data length Without parity 8 bit
 With parity 7 bit

- Stop bit Select from 1 and 2.

NOTICE Set the baud rate to 1200 and the stop bit to 1 when using the EP-60A.

Selecting the baud rate

(1) Press the [MODE] key to display "iF" (see "5. Menu Selection").



(2) Press the [TARE] key to display "bPS".



(3) Press the [TARE] key.

(4) "300" is displayed. The display changes in the following order by pressing the [MODE] key: 300 -> 600 -> 1200 -> 2400 -> 4800 -> 9600 -> 300... The currently selected baud rate is displayed with the stability mark.

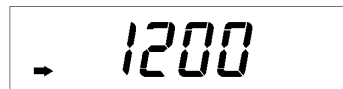

(5) Select the desired baud rate and press the [TARE] key.

Selecting the parity

(1) Press the [MODE] key to display "iF".

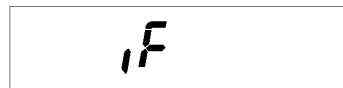

(2) Press the [TARE] key to display "bPS".

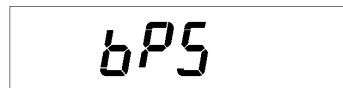

(3) Press the [MODE] key to display "Prty".

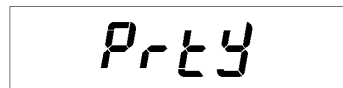

(4) Press the [TARE] key to display "EvEn".

(5) The display changes in the following order by pressing the [MODE] key: EvEn -> odd -> non -> EvEn...

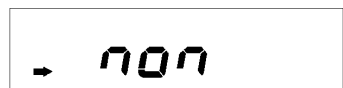

The currently selected parity is displayed with the stability mark.

(6) Select the desired parity and press the [TARE] key.

* The data length becomes 7 bits if "EvEn" or "odd" is selected for the parity.

Selecting the stop bit

(1) Press the [MODE] key to display "iF".

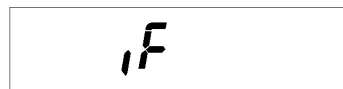

(2) Press the [TARE] key to display "bPS".

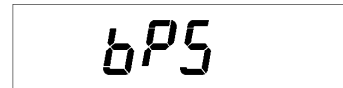

(3) Press the [MODE] key to display "StoP".

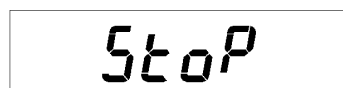

- (4) Press the [TARE] key to display "1".
- (5) The display changes in the following order by pressing the [MODE] key: 1 -> 2 -> 1...
The currently selected stop bit is displayed with the stability mark.
- (6) Select the desired stop bit and press the [TARE] key.



19.2.4 Command Codes

Shown below are commands available when the balance is connected to external devices such as a personal computer. See "19.2.3 Input/Output Format" for information on data formats.

Inputting characters or control codes that are not listed below may impede the proper operation of the balance or the performance of correct measurements.

When connecting the balance to external devices to conduct unattended operation, take appropriate precautionary measures against unexpected communication failure (setting a waiting time for input, for example).

Command code	Function	Description
T	Subtraction of the container weight	Zeros the display.
D05	Print (once)	Outputs the displayed data.
D06	Auto Print *	Outputs the displayed data automatically when the display stabilizes after an object is placed on the pan while zero is displayed.
D01	Continuous output *	Outputs the displayed data continuously at an interval of approx. 100ms.
D09	Output stop	Stops Auto Print and continuous output.
D07	Single output with stability information	Outputs the data once with the internal stability information.
D03	Continuous output with stability information *	Outputs the data continuously with the internal stability information.

Commands with "*" are cancelled by pressing the [ON/OFF(BREAK)], [UNIT], or [MODE] key.