

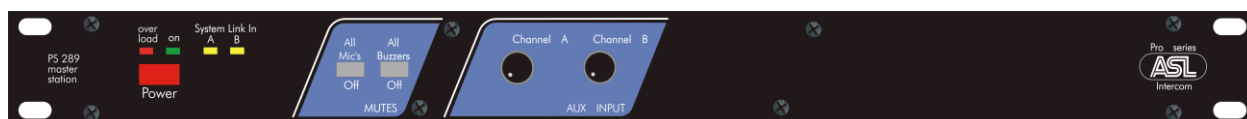

PS 289

DUAL CHANNEL POWER SUPPLY



USER MANUAL

Issue 2011 © ASL Intercom BV

DESIGNED AND MANUFACTURED BY:

ASL INTERCOM B.V.
ZONNEBAAN 42
3542 EG UTRECHT
THE NETHERLANDS
PHONE: +31 (0)30 2411901
FAX: + 31 (0)30 2667373
E-MAIL: info@asl-inter.com
WEB: www.asl-inter.com

CONTENT OF THIS USER MANUAL

| | | |
|------|--|---|
| 1.0 | SAFETY INSTRUCTIONS..... | 3 |
| 2.0 | UNPACKING..... | 3 |
| 3.0 | WARRANTY | 3 |
| 4.0 | MECHANICAL INSTALLATION | 4 |
| 5.0 | MAINS POWER..... | 4 |
| 6.0 | GENERAL DESCRIPTION PS 289..... | 4 |
| 7.0 | FRONT PANEL CONTROLS AND CONNECTOR | 5 |
| 8.0 | TECHNICAL SPECIFICATIONS PS 289 | 5 |
| 9.0 | REAR PANEL CONTROLS AND CONNECTORS | 6 |
| 10.0 | PS 289 BLOCK DIAGRAM..... | 6 |
| 11.0 | PARTY LINE, TECHNICAL CONCEPT | 7 |
| 12.0 | CABLING | 7 |
| 13.0 | EARTHING CONCEPT..... | 8 |
| 14.0 | POSSIBLE SYSTEM CONFIGURATION | 8 |

1.0 SAFETY INSTRUCTIONS

- 1) Read all safety and operating instructions before you operate the apparatus.
- 2) Retain all safety and operating instructions for future reference.
- 3) Read all warnings on the apparatus and in the safety and operating instructions.
- 4) Follow all instructions for installation, operating and use.
- 5) Unplug the apparatus from the AC power outlet before cleaning. Use only a damp cloth for cleaning the exterior of the apparatus.
- 6) Do not use accessories or attachments not recommended by the manufacturer, as they may cause hazards and void the warranty.
- 7) Do not operate this apparatus in high humidity areas or expose it to water or moisture.
- 8) Do not place the apparatus on an unstable cart, stand, tripod, bracket or table. The apparatus may fall, causing serious personal injury and damage to the apparatus.
- 9) Do not block or cover any openings in the apparatus. These are provided for ventilation and protection from overheating. Never place the apparatus near any heat sources such as radiators, heat registers, stoves, or other apparatus (including amplifiers) that produce heat. Do not place the apparatus in an enclosure such as a cabinet without proper ventilation.
- 10) Operate the apparatus using only the type of power source indicated on the marking label. Unplug the apparatus' power cord by gripping the power plug, not the cord.
- 11) Insert the plug properly. Do not defeat the safety purpose of the polarized or grounding type plug. A polarized AC line plug has two blades with one wider than the other. This plug will fit into the power outlet only one way. This is a safety feature. If you are unable to insert the plug fully into the outlet, try reversing the plug. If the plug still fails to fit, contact an electrician to replace the obsolete outlet. A grounding type plug has two blades and a third grounding prong. The wide blade or the third prong are provided for your safety. If the provided plug does not fit into your outlet, consult an electrician to replace the obsolete outlet.
- 12) Route power supply cords so that they are not likely to be walked on or pinched by items placed upon or against them. Pay particular attention to cords at plugs, convenience receptacles, and the point where they exit from the apparatus.
- 13) Do not overload wall outlets or extension cords, as this can result in a risk of fire or electrical shock.
- 14) Unplug this apparatus during lightning storms or when unused for long periods of time.
- 15) Never insert objects of any kind into the apparatus through openings, as the objects may touch dangerous voltage points or short out parts. This could cause fire or electrical shock.
- 16) Refer all servicing to qualified service personnel. Servicing is required when the apparatus has been damaged in any way, such as when the power-supply cord or plug is damaged, liquid has been spilled or objects have fallen into the apparatus, the apparatus has been exposed to rain or moisture, does not operate normally, or has been dropped.

2.0 UNPACKING

The shipping carton contains:

- The PS 289
- Mains power cable
- Spare fuses (T 1250)
- This user manual

If any are missing, contact your dealer.

After unpacking the unit, please inspect for any physical damage to the unit, and retain the shipping carton and relevant packing materials for use should the unit need returning. If any damage has occurred, please notify your dealer immediately so that a written claim can be initiated. Please also refer to the warranty section of this manual.

3.0 WARRANTY

ASL Intercom warrants this unit against defects in workmanship and materials in its manufacture for a period of one year from the date of shipment to the end-user.

Faults arising from misuse, unauthorized modifications or accidents are not covered by this warranty. If the unit is faulty, send it in its original packing to the supplier or your local ASL dealer, with shipping prepaid. A note must be included stating the faults found and a copy of the original suppliers invoice.

4.0 MECHANICAL INSTALLATION

A vertical rack space of 1U (1.75" / 44,5 mm) is required for the PS 289. It is not necessary to provide rear support by extra bracing or shelving.

Adequate ventilation must be provided by allowing sufficient space around the sides and rear of the

unit to ensure free circulation of air. Forced cooling is not required.

The power supply module is mounted on the bottom of the PS 289. After a period of time it will feel hot to the touch on top and bottom. This is normal and should be no cause for alarm.

5.0 MAINS POWER

WARNING

This appliance must be earthed

The PS 289 may be connected to a mains power outlet of 100 - 240 V AC (50 - 60 Hz), 100 watts. The outlet should have a clean earth. Avoid using mains power outlets which also power dimmer controlled lighting equipment.
Fuse type for all voltages: T 1250

The wires in the mains lead are color coded:

Green/yellow: safety ground
Blue: neutral
Brown: live

In case the colors of the wires in the mains lead do not correspond with the colored markings of the terminals in your plug, proceed as follows:

- The wire that is colored green-and-yellow must be connected to the terminal in the plug, which is marked with the letter "E", or by the ground symbol, or is colored green.
- The wire that is colored blue must be connected to the terminal that is marked with the letter "N" or colored black.
- The wire that is colored brown must be connected to the terminal marked with the letter "L" or colored red.

The green-and-yellow wire of the mains cord must always be connected to the electrical installation safety earth or ground. It is essential for personal safety as well as for proper operation of the PS 289 and the other connected stations. This wire is internally connected to all exposed metal surfaces. Any rack framework into which this unit might be mounted shall be connected to the same grounding circuit.

The PS 289 employs professionally designed audio input and output circuits which do not require the disconnection of any safety earth to avoid hum loops.

Powering up procedure:

- Make sure that the red power switch on the left side of the front panel is OFF.
- Connect the power cord to the rear of the station.
- Plug the other end of the power cord into a PROPERLY GROUNDED outlet.
- Turn on the power with the red button. The red overload LED will light up for about 3 seconds, then extinguishes and the green power LED will switch on, indicating the station is active.

6.0 GENERAL DESCRIPTION PS 289

The PS 289 is designed to be a dual channel power supply in an ASL intercom system. This 19"/1RU unit is ideal for use where standard microphone cable is available and ease of setup is of paramount importance.

The intercom line power supply is fully protected and can drive at least 20 belt packs or 10 speaker stations operating at full power.

Since the power supply provides the line impedance, one uses only one PS 289 in a 2-channel Intercom system. In case the number of user stations in such an intercom system exceed the capacity of the PS 289, the PS 285 booster power supply can be used.

Should the PS 289 be connected to another Intercom system, the 'System link' connector at the rear of the unit has to be used to avoid impedance problems.

Fully electronic switching increases reliability and allows for remote Buzzer Mute and Mic Mute facility: All microphones of stations connected to the PS 289 can be muted by pushing a single button on the front panel.

An Aux input at the rear panel allows inserting external audio signals, which can be volume controlled routed to intercom line A and/or B.

In case a 100/240 V AC power is not available, the PS 289 can be powered by an external DC power supply, to be connected to the unit via a DC Input connector at the rear panel.

7.0 FRONT PANEL CONTROLS AND CONNECTOR

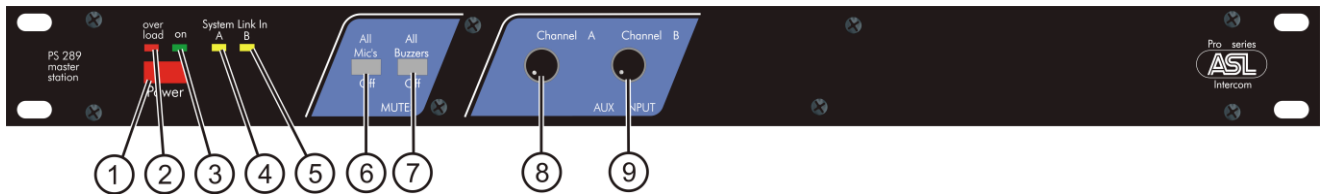

1 POWER ON/OFF switch

Mains power push button for switching the PS 289 on and off

2 OVERLOAD LED

This red LED illuminates when the circuit breaker shuts off line power due to overload. A cause for overload can be too many user stations connected or a short circuit in the interconnecting cables. The circuit breaker resets automatically 3 seconds after the cause of the overload has been removed and restores the line power. During short circuit, the LED flashes every 3 seconds. Every time mains power is switched on, the LED is lit for a few seconds.

3 POWER LED

This green LED illuminates when the unit is switched on.

4 SYSTEM LINK LED / CHANNEL A

This LED illuminates if a channel of another ASL Intercom System has been connected to channel A of the PS 289, through its "System Link" connector. The Line Impedance is now provided by the other Intercom system and the internal line impedance for Channel A is switched off.

A Mic Mute signal sent from the other intercom system is also received by the user stations on channel A. But a Mic Mute signal sent from the PS

289 is only received by the user stations on its own channels (it does not mute the microphones of the user stations of the other intercom system).

Buzzer Mute signals are not going from the other intercom system to the PS 289, nor in the opposite direction.

See #8 for "Mic Mute" and #9 for "Buzzer Mute".

5 SYSTEM LINK LED / CHANNEL B

Same as #4, but for channel B.

6 ALL MIC'S ON/OFF button

With this push button the microphones of all connected stations can be switched off. On each user station the microphone can be activated again by pushing a TALK button.

7 ALL BUZZERS ON/OFF button

With this push button all buzzers of the connected user stations can be muted. The buzzers remain muted until the Mute button is switched off again.

8 AUX VOLUME knob (channel A)

This knob controls the level of the Aux input signal to intercom line channel A.

9 AUX VOLUME knob (channel B)

This knob controls the level of the Aux input signal to intercom line channel B

8.0 TECHNICAL SPECIFICATIONS PS 289

Intercom System

Dynamic range: 80 dB
Call send signal: +2.8 mA
Call receive signal threshold: +2.4V DC
Supply voltage: +30 V DC (12 - 32 V DC)
Power interrupt time (mic mute): 0.1 sec.

Intercom Line

Impedance: 350 Ω (1kHz)/ 2.2 k Ω (DC)
Audio level: nom. -18 dBu, max. +4 dBu

Switch Mode Power Supply

Mains voltage: 100 - 240V AC, 50/60Hz
Output voltage: +30V DC (+/- 5%)
Max. output power: 75 Watts
Circuit breaker delay time: 0.2 sec.
Automatic reset time: 3.0 sec.

DC Input

Supply voltage: 12 – 28 V DC

Aux input (Line level)

Input impedance: 11 k Ω
Nominal input level: -20 to +10 dBu
Max. input level: +21 dBu

Dimensions & Weight

Width: 19" (483 mm)
Height: 1U (44,5 mm)
Depth: 150 mm
Weight: 1.85 kg

0 dBu defined as 775 mV into open circuit

ASL reserves the right to alter specifications without prior notice

9.0 REAR PANEL CONTROLS AND CONNECTORS

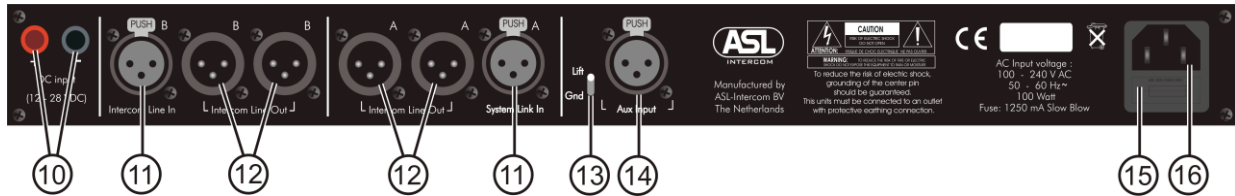

10 DC INPUT connectors

In case 100/240 V AC power is not available, the PS 289 can be powered by a DC supply (12 – 28 V), to be connected to the unit via these connectors

11 SYSTEM LINK IN connectors

Inputs for the cable of an external party-line Intercom system. If one or both channels of the PS 289 are to be connected to another intercom system then these connectors accept the communication signals from the other system. See also #4 and #5.

12 A & B LINE connectors

These XLR-3 connectors are for connecting the user stations, via standard microphone cable. There are 2 connectors for channel A and two connectors for channel B.

Pin assignment:

- pin 1: 0V / ground shield
- pin 2: +30V power wire
- pin 3: audio wire

13 GROUND LIFT switch

With this switch the pin 1 of the AUX input XLR is lifted from ground when in "Lift" position.

14 AUX INPUT connector

This XLR-3 aux input is for electronically balanced audio and accepts levels between –20 dBu to +21 dBu on line level.

Pin assignment:

- Pin 1: 0V / ground,
- Pin 2: signal +,
- Pin 3: signal

15 FUSE holder

A fuse protects the PS 279 against severe internal damage in case of malfunction in the power section. Spare fuses are supplied with the unit.

Before replacing the fuse the mains cord must be removed. Make sure that the correct fuse (T 1250) is placed in the holder

16 MAINS INLET

IEC Mains connector.

10.0 PS 289 BLOCK DIAGRAM

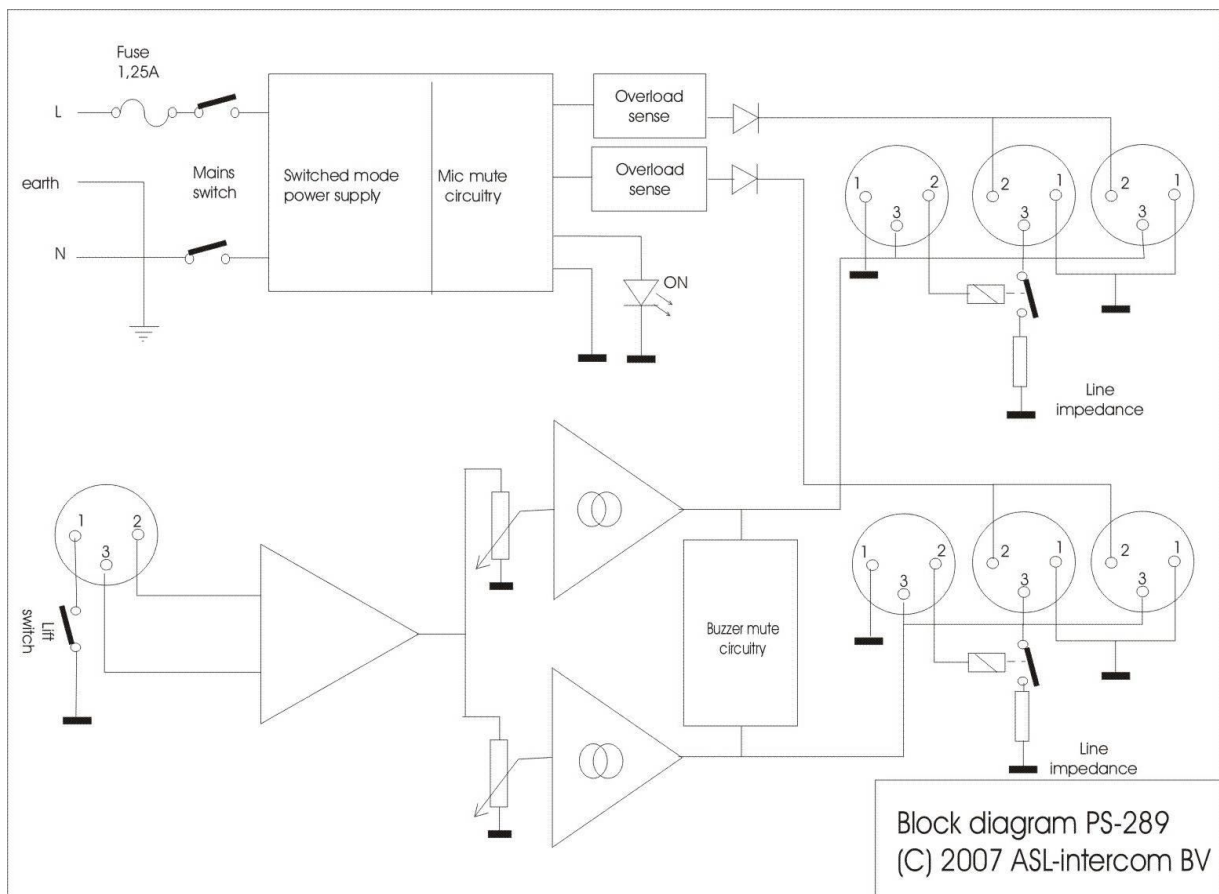

11.0 PARTY LINE, TECHNICAL CONCEPT

User stations in an ASL intercom system are connected via one or several 'party lines'. A party line offers two way ('full duplex') communication and consists of standard microphone (multi-pair) cable. One wire is used as an audio line, one as a power line and the screen of the cable functions as earth/return.

Current drive is used for signal transfer. Each station utilizes a current amplifier to amplify the microphone signal and place it on the common audio line where, due to the constant line impedance (situated in the power supply between XLR pin 3 and 1), a signal voltage is developed which can be further amplified and sent to the headphones or loudspeakers.

This principle has three advantages:

- the use of a single audio line allows several stations to talk and listen simultaneously
- due to the high bridging impedance offered by each station, the number of stations on the party line has no influence on the level of the communications signal
- power and audio to the intercom stations use the same cable

The Call signal is also sent as a current on the audio line. It develops a DC potential over the line impedance which will be sensed by each station and interpreted as a Call signal.

12.0 CABLING

The intercom lines (the 'party lines') are of the shielded two-conductor microphone cable type. The intercom line connectors are of the XLR-3 type. Audio and Call signals are on XLR pin 3, DC power is on XLR pin 2. XLR pin 1 is connected to the shield of the cable which functions as the common return for audio and power. The audio signal is transferred in an unbalanced way (see 'Party Line, Technical Concept'). To avoid earth loops (hum), the possible effect of electromagnetic fields and to minimize power loss, certain rules have to be obeyed when installing the cabling of an intercom system :

Use high quality cable

Use high quality microphone cable (shielded two conductor cable, minimum 2x 0.30 mm²). In case multi-pair microphone cable is used, it should be of high quality and each pair should consist of two conductors (minimum 2x 0.15 mm²) with separate shield and an overall shield.

Use flexible cable

Use flexible single and multi-pair microphone cable instead of cable with solid cores, especially when the cable is subjected to bending during operation or installation.

Cable screens to XLR pin 1

The screen of each separate microphone cable and/or the screen of each single pair in a multi-pair cable, should be connected to pin 1 of each XLR-3 connector. Do not connect these screens to the metal housing of ASL units or XLR-3 wall boxes. See section 'Earthing Concept'.

Connect metal cable trunks, wall boxes and overall multi-pair cable screens to clean earth

Metal cable trunks, metal wall boxes and overall multi-pair cable screens should be interconnected and, at the 'central earth point' in the intercom network only, be connected to a clean earth or a safety earth. (see section 'Earthing Concept').

Keep metal connection boxes and cable trunks or pipes isolated from other metal parts

Metal trunks or pipes for intercom cables and metal connection boxes should be mounted in such a way that they are isolated from any other metal housing or construction part.

Keep cables parallel as much as possible

When two (multi channel) units in a network are connected by more than one cable, make sure that these cables are parallel to each other over the whole distance between those units. When using multi-pair cable, parallelism is ensured in the best possible way.

Avoid closed loops

Always avoid that intercom cables are making a closed loop. So-called 'ring intercom' should not physically be cabled as a ring..

Keep cables away from electromagnetic sources

Keep intercom cables away from high energy cables, e.g. 115/230/400V mains power or dimmer controlled feeds for spotlights. Intercom cables should cross high energy cables at an angle of 90° only. Intercom cables should never be in the same trunks as energy cables.

Place power supply in a central position

In case of a system powered by a separate power supply: In order to diminish power losses, place the power supply as close as possible to where most power consumption occurs, in other words most user stations are placed.

ASL powered units to a 'clean' mains outlet

Master stations or power supplies should be connected to a mains outlet with a clean earth. Other audio equipment may be connected to this mains outlet, but avoid using an outlet which also powers dimmer controlled lighting systems.

13.0 EARTHING CONCEPT

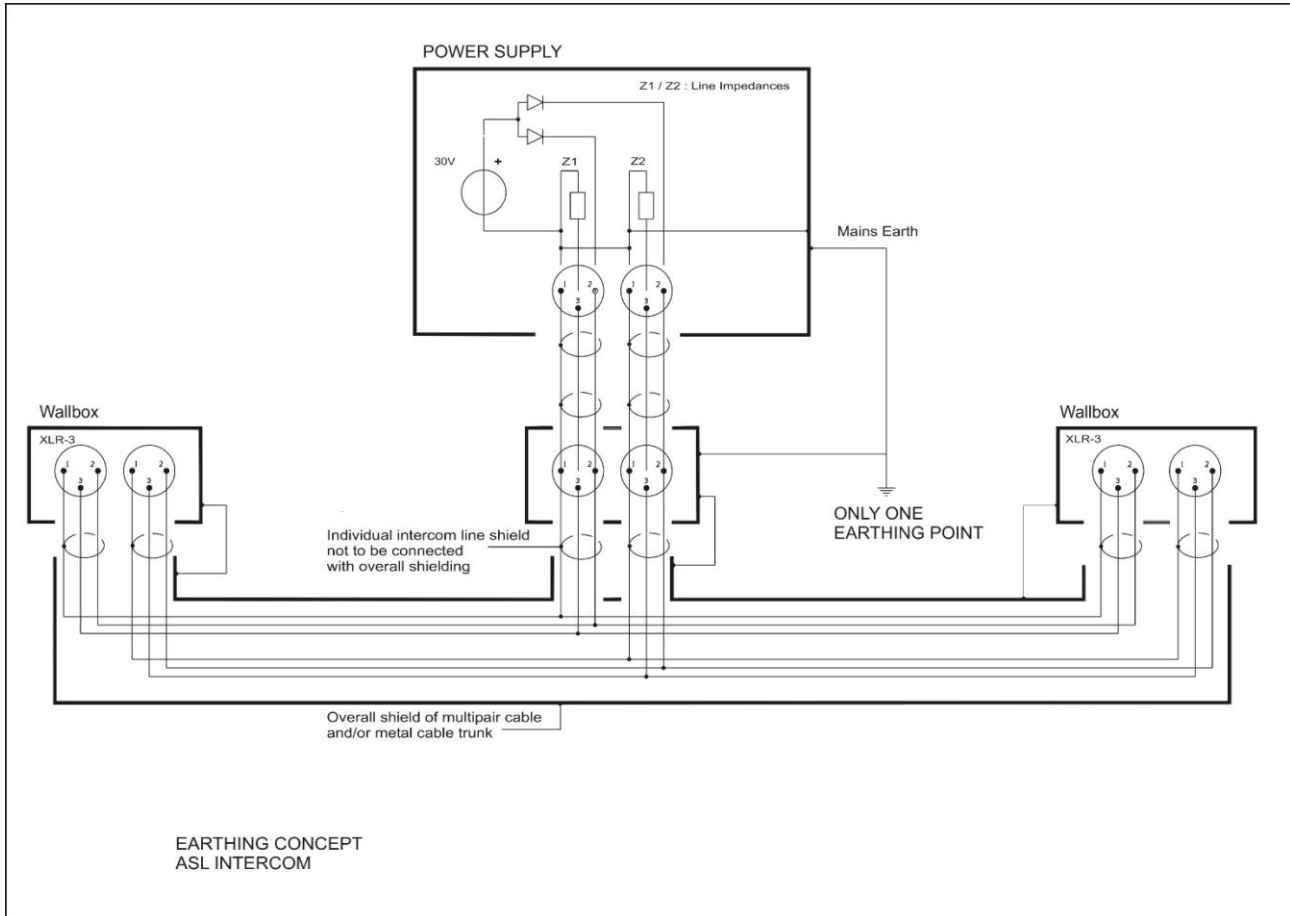

14.0 POSSIBLE SYSTEM CONFIGURATION

