

User Manual



ULTRA-DI PRO DI4000

Professional 4-Channel Active DI-Box

Table of Contents

- Important Safety Instructions 3**
- Legal Disclaimer 3**
- Limited Warranty 3**
- 1. Introduction 5**
 - 1.1 Before you begin..... 5
 - 1.2 Online registration 5
 - 1.3 Control elements 6
- 2. Applications 6**
 - 2.1 Tapping signal from a (bass) guitar 6
 - 2.2 Converting the output of a keyboard /
DJ-mixer / headphone plug..... 7
 - 2.3 Converting a microphone signal 7
 - 2.4 Tapping a signal from a power amplifier output 7
- 3. Installation 7**
 - 3.1 Rack mounting..... 7
 - 3.2 Mains connection 7
 - 3.3 Audio connections..... 8
- 4. Specifications..... 9**

EN Important Safety Instructions



Terminals marked with this symbol carry electrical current of sufficient magnitude to constitute risk of electric shock. Use only high-quality commercially-available speaker cables with ¼" TS plugs pre-installed. All other installation or modification should be performed only by qualified personnel.



This symbol, wherever it appears, alerts you to the presence of uninsulated dangerous voltage inside the enclosure - voltage that may be sufficient to constitute a risk of shock.



This symbol, wherever it appears, alerts you to important operating and maintenance instructions in the accompanying literature. Please read the manual.



Caution

To reduce the risk of electric shock, do not remove the top cover (or the rear section). No user serviceable parts inside. Refer servicing to qualified personnel.



Caution

To reduce the risk of fire or electric shock, do not expose this appliance to rain and moisture. The apparatus shall not be exposed to dripping or splashing liquids and no objects filled with liquids, such as vases, shall be placed on the apparatus.



Caution

These service instructions are for use by qualified service personnel only. To reduce the risk of electric shock do not perform any servicing other than that contained in the operation instructions. Repairs have to be performed by qualified service personnel.

1. Read these instructions.
2. Keep these instructions.
3. Heed all warnings.
4. Follow all instructions.
5. Do not use this apparatus near water.
6. Clean only with dry cloth.
7. Do not block any ventilation openings. Install in accordance with the manufacturer's instructions.
8. Do not install near any heat sources such as radiators, heat registers, stoves, or other apparatus (including amplifiers) that produce heat.

9. Do not defeat the safety purpose of the polarized or grounding-type plug. A polarized plug has two blades with one wider than the other. A grounding-type plug has two blades and a third grounding prong. The wide blade or the third prong are provided for your safety. If the provided plug does not fit into your outlet, consult an electrician for replacement of the obsolete outlet.

10. Protect the power cord from being walked on or pinched particularly at plugs, convenience receptacles, and the point where they exit from the apparatus.

11. Use only attachments/accessories specified by the manufacturer.



12. Use only with the cart, stand, tripod, bracket, or table specified by the manufacturer, or sold with the apparatus. When a cart is used, use caution when moving the cart/apparatus combination to avoid

injury from tip-over.

13. Unplug this apparatus during lightning storms or when unused for long periods of time.

14. Refer all servicing to qualified service personnel. Servicing is required when the apparatus has been damaged in any way, such as power supply cord or plug is damaged, liquid has been spilled or objects have fallen into the apparatus, the apparatus has been exposed to rain or moisture, does not operate normally, or has been dropped.

15. The apparatus shall be connected to a MAINS socket outlet with a protective earthing connection.

16. Where the MAINS plug or an appliance coupler is used as the disconnect device, the disconnect device shall remain readily operable.



LEGAL DISCLAIMER

TECHNICAL SPECIFICATIONS AND APPEARANCE ARE SUBJECT TO CHANGE WITHOUT NOTICE. THE INFORMATION CONTAINED HEREIN IS CORRECT AT THE TIME OF PRINTING. ALL TRADEMARKS ARE THE PROPERTY OF THEIR RESPECTIVE OWNERS. MUSIC GROUP ACCEPTS NO LIABILITY FOR ANY LOSS WHICH MAY BE SUFFERED BY ANY PERSON WHO RELIES EITHER WHOLLY OR IN PART UPON ANY DESCRIPTION, PHOTOGRAPH OR STATEMENT CONTAINED HEREIN. COLORS AND SPECIFICATIONS MAY VARY FROM ACTUAL PRODUCT. MUSIC GROUP PRODUCTS ARE SOLD THROUGH AUTHORIZED FULLFILLERS AND RESELLERS ONLY. FULLFILLERS AND RESELLERS ARE NOT AGENTS OF MUSIC GROUP AND HAVE ABSOLUTELY NO AUTHORITY TO BIND MUSIC GROUP BY ANY EXPRESS OR IMPLIED

UNDERTAKING OR REPRESENTATION. THIS MANUAL IS COPYRIGHTED. NO PART OF THIS MANUAL MAY BE REPRODUCED OR TRANSMITTED IN ANY FORM OR BY ANY MEANS, ELECTRONIC OR MECHANICAL, INCLUDING PHOTOCOPYING AND RECORDING OF ANY KIND, FOR ANY PURPOSE, WITHOUT THE EXPRESS WRITTEN PERMISSION OF MUSIC GROUP IP LTD.

ALL RIGHTS RESERVED.

© 2011 MUSIC Group IP Ltd.

Trident Chambers, Wickhams Cay, P.O. Box 146, Road Town, Tortola, British Virgin Islands

LIMITED WARRANTY

§ 1 Warranty

① This limited warranty is valid only if you purchased the product from a MUSIC Group Authorized Reseller in the country of purchase. A list of authorized resellers can be found on BEHRINGER's website behringer.com under "Where to Buy", or you can contact the MUSIC Group office closest to you.

② MUSIC Group* warrants the mechanical and electronic components of this product to be free of defects in material and workmanship if used under normal operating conditions for a period of one (1) year from the original date of purchase (see the Limited Warranty terms in § 4 below), unless a longer minimum warranty period is mandated by applicable local laws. If the product shows any defects within the specified warranty period and that defect is not excluded under § 4, MUSIC Group shall, at its discretion, either replace or repair the product using suitable new or reconditioned product or parts. In case MUSIC Group decides to replace the entire product, this limited warranty shall apply to the replacement product for the remaining initial warranty period, i.e., one (1) year (or otherwise applicable minimum warranty period) from the date of purchase of the original product.

③ Upon validation of the warranty claim, the repaired or replacement product will be returned to the user freight prepaid by MUSIC Group.

④ Warranty claims other than those indicated above are expressly excluded.

PLEASE RETAIN YOUR SALES RECEIPT. IT IS YOUR PROOF OF PURCHASE COVERING YOUR LIMITED WARRANTY. THIS LIMITED WARRANTY IS VOID WITHOUT SUCH PROOF OF PURCHASE.

§ 2 Online registration

Please do remember to register your new BEHRINGER equipment right after your purchase at behringer.com under "Support" and kindly read the terms and conditions of our limited warranty carefully. Registering your purchase and equipment with us helps us process your repair claims quicker and more efficiently. Thank you for your cooperation!

§ 3 Return materials authorization

① To obtain warranty service, please contact the retailer from whom the equipment was purchased. Should your MUSIC Group Authorized Reseller not be located in your vicinity, you may contact the MUSIC Group Authorized Fulfiller for your country listed under

“Support” at behringer.com. If your country is not listed, please check if your problem can be dealt with by our “Online Support” which may also be found under “Support” at behringer.com. Alternatively, please submit an online warranty claim at behringer.com BEFORE returning the product. All inquiries must be accompanied by a description of the problem and the serial number of the product. After verifying the product’s warranty eligibility with the original sales receipt, MUSIC Group will then issue a Return Materials Authorization (“RMA”) number.

② Subsequently, the product must be returned in its original shipping carton, together with the return authorization number to the address indicated by MUSIC Group.

③ Shipments without freight prepaid will not be accepted.

§ 4 Warranty Exclusions

① This limited warranty does not cover consumable parts including, but not limited to, fuses and batteries. Where applicable, MUSIC Group warrants the valves or meters contained in the product to be free from defects in material and workmanship for a period of ninety (90) days from date of purchase.

② This limited warranty does not cover the product if it has been electronically or mechanically modified in any way. If the product needs to be modified or adapted in order to comply with applicable technical or safety standards on a national or local level, in any country which is not the country for which the product was originally developed and manufactured, this modification/adaptation shall not be considered a defect in materials or workmanship. This limited warranty does not cover any such modification/adaptation, regardless of whether it was carried out properly or not. Under the terms of this limited warranty, MUSIC Group shall not be held responsible for any cost resulting from such a modification/adaptation.

③ This limited warranty covers only the product hardware. It does not cover technical assistance for hardware or software usage and it does not cover any software products whether or not contained in the product. Any such software is provided “AS IS” unless expressly provided for in any enclosed software limited warranty.

④ This limited warranty is invalid if the factory-applied serial number has been altered or removed from the product.

⑤ Free inspections and maintenance/repair work are expressly excluded from this limited warranty, in particular, if caused by improper handling of the product by the user. This also applies to defects caused by normal wear and tear, in particular, of faders, crossfaders, potentiometers, keys/buttons, guitar strings, illuminants and similar parts.

⑥ Damage/defects caused by the following conditions are not covered by this limited warranty:

- improper handling, neglect or failure to operate the unit in compliance with the instructions given in BEHRINGER user or service manuals;

- connection or operation of the unit in any way that does not comply with the technical or safety regulations applicable in the country where the product is used;
- damage/defects caused by acts of God/Nature (accident, fire, flood, etc) or any other condition that is beyond the control of MUSIC Group.

⑦ Any repair or opening of the unit carried out by unauthorized personnel (user included) will void the limited warranty.

⑧ If an inspection of the product by MUSIC Group shows that the defect in question is not covered by the limited warranty, the inspection costs are payable by the customer.

⑨ Products which do not meet the terms of this limited warranty will be repaired exclusively at the buyer’s expense. MUSIC Group or its authorized service center will inform the buyer of any such circumstance. If the buyer fails to submit a written repair order within 6 weeks after notification, MUSIC Group will return the unit C.O.D. with a separate invoice for freight and packing. Such costs will also be invoiced separately when the buyer has sent in a written repair order.

⑩ MUSIC Group Authorized Resellers do not sell new products directly in online auctions. Purchases made through an online auction are on a “buyer beware” basis. Online auction confirmations or sales receipts are not accepted for warranty verification and MUSIC Group will not repair or replace any product purchased through an online auction.

§ 5 Warranty transferability

This limited warranty is extended exclusively to the original buyer (customer of authorized reseller) and is not transferable to anyone who may subsequently purchase this product. No other person (reseller, etc.) shall be entitled to give any warranty promise on behalf of MUSIC Group.

§ 6 Claim for damage

Subject only to the operation of mandatory applicable local laws, MUSIC Group shall have no liability to the buyer under this warranty for any consequential or indirect loss or damage of any kind. In no event shall the liability of MUSIC Group under this limited warranty exceed the invoiced value of the product.

§ 7 Limitation of liability

This limited warranty is the complete and exclusive warranty between you and MUSIC Group. It supersedes all other written or oral communications related to this product. MUSIC Group provides no other warranties for this product.

§ 8 Other warranty rights and national law

① This limited warranty does not exclude or limit the buyer’s statutory rights as a consumer in any way.

② The limited warranty regulations mentioned herein are applicable unless they constitute an infringement of applicable mandatory local laws.

③ This warranty does not detract from the seller’s obligations in regard to any lack of conformity of the product and any hidden defect.

§ 9 Amendment

Warranty service conditions are subject to change without notice. For the latest warranty terms and conditions and additional information regarding MUSIC Group’s limited warranty, please see complete details online at behringer.com.

* MUSIC Group Macao Commercial Offshore Limited of Rue de Pequim No. 202-A, Macau Finance Centre 9/J, Macau, including all MUSIC Group companies

1. Introduction

Whether you are on the stage or in the studio, you often find that you need to connect an audio source to your mixing console, but you don't have the appropriate connectors. For example, only few keyboards feature balanced outputs; guitars should not be connected directly to the console; and placing a microphone in front of an amp is not always an ideal solution, because the mic will pick up unwanted signals from other instruments, too. Low frequency signals (e.g. produced by a bass guitar) are particularly difficult to handle using these techniques.

"DI" is short for "Direct Injection". A Direct Inject box allows you to use a high-impedance, unbalanced source, e.g. the signal between guitar and guitar amp, and feed it directly into an input channel on your console, without having to use a microphone. And that's far from being all. There are plenty of situations in which you'd like to input unbalanced source signals into your console, and possibly convert them to balanced signals before. As you can expect, the DI4000 offers you a reliable solution.

The following explanations will give you an introduction to the complex performance-impedance issue: impedance is defined as the dependence of a device's electrical resistance and phase response on the frequency processed. Thus, impedance is one of the criteria that distinguish good DI boxes from poor ones. Much like in a power amp and its connected speakers, impedance determines the performance of the device. With a good power amp, the load impedance will have little influence on the maximum output power, but it can considerably affect other properties. With a passive DI box, the connected load impedances (ins and outs) alter the bandwidth, frequency response, distortion, etc. of the DI box.

By the way: there are two basic types of DI boxes, passive and active. Both can be connected to one of the console's mic inputs. Passive DI boxes offer the advantage that they are less expensive than active models (less electronics, no power supply), however, their performance depends on the connected impedance. With a passive DI box connected, any impedance change on the console side will also modify the input impedance. The frequency response will always depend on the impedances connected. Any passive DI box will only perform properly with accurately specified impedances (high on the input side, low at the output), i.e. it will only work in standard situations.

Active DI boxes such as our ULTRA-DI PRO, however, do not suffer from such restrictions, because they use an amplifier circuit to buffer the input signal. Since the ULTRA-DI PRO's input impedance is ultra-high, the signal remains unaffected as it passes through the DI box. Additionally, the ULTRA-DI PRO features balanced impedances on the output side, making the signal less susceptible to hum and noise interference. In this way, the signal as source impedance is completely independent of the console used (and vice versa), which means that the sound remains totally unaffected. The ULTRA-DI PRO uses our proven OT-1 transformer which ensures a clear and distortion-free sound and linear frequency response. Additionally, the ULTRA-DI PRO comes with a built-in power supply.

Future-oriented BEHRINGER technology

The ULTRA-DI PRO is based on SMD technology (Surface Mounted Devices). These subminiature components known from aerospace applications ensure both extreme packing density and greater reliability.

High-quality components and design

The philosophy behind BEHRINGER products guarantees a no-compromise circuit design and employs the best choice of components. The op-amps, type 4580, used in the ULTRA-DI PRO are chosen for their superior signal-to-noise ratio, low distortion and linear performance. Additionally, the ULTRA-DI PRO uses high quality resistors and capacitors with very tight tolerances, high-grade switches as well as other selected components.

◆ **This manual first describes the terminology used, so that you can fully understand the ULTRA-DI PRO and its functions. Please read the manual carefully and keep it for future reference.**

1.1 Before you begin

Your BEHRINGER ULTRA-DI PRO was carefully packed in the factory and the packaging was designed to protect the unit from rough handling. Nevertheless, we recommend that you carefully examine the packaging and its contents for any signs of physical damage, which may have occurred in transit.

◆ **If the unit is damaged, please do not return it to us, but notify your dealer and the shipping company immediately, otherwise claims for damage or replacement may not be granted. Shipping claims must be made by the consignee.**

The BEHRINGER ULTRA-DI PRO fits into one standard 19" rack unit of space. Please allow at least an additional 4" (10 cm) depth for the connectors on the back panel.

◆ **Be sure that there is enough space around the unit for cooling and please do not place the ULTRA-DI PRO on high temperature devices such as power amplifiers etc. to avoid overheating.**

The mains connection of the ULTRA-DI PRO is made by using the supplied cable. It meets all of the international safety certification requirements. Please make sure that all units have a proper ground connection.

◆ **Before you connect your ULTRA-DI PRO to the mains, please make sure that your local voltage matches the voltage required by the unit!**

1.2 Online registration

Please register your new BEHRINGER equipment right after your purchase by visiting <http://behringer.com> and read the terms and conditions of our warranty carefully.

Should your BEHRINGER product malfunction, it is our intention to have it repaired as quickly as possible. To arrange for warranty service, please contact the BEHRINGER retailer from whom the equipment was purchased. Should your BEHRINGER dealer not be located in your vicinity, you may directly contact one of our subsidiaries. Corresponding contact information is included in the original equipment packaging (Global Contact Information/European Contact Information). Should your country not be listed, please contact the distributor nearest you. A list of distributors can be found in the support area of our website (<http://behringer.com>).

Registering your purchase and equipment with us helps us process your repair claims more quickly and efficiently.

Thank you for your cooperation!

1.3 Control elements

The BEHRINGER ULTRA-DI PRO has four identical channels. The control elements are identical on all channels.

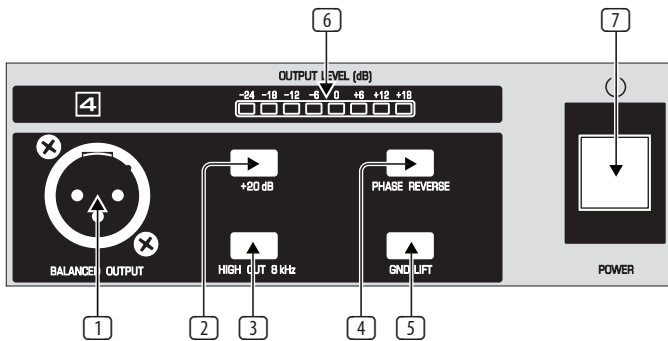

Fig. 1.1: Control and display elements on the front panel

- 1 **OUTPUT.** This is the balanced output of the ULTRA-DI PRO. The connection to the mixing desk should be made with a standard high-quality balanced cable.
- 2 **+20 dB** gain switch for pre-amplification of low level signals.
- 3 Switchable **HIGH CUT** filters (8 kHz) for guitar applications (6 dB/Oct).
- 4 With the **PHASE REVERSE** switch the input signal is reversed in phase by 180°.
- 5 Use the **GND LIFT** switch to either connect the ground of input and output or keep them completely separate. Depending on the grounding of the connected devices linking or disconnecting will reduce hum or prevent ground loops. **GROUND LIFT** on means no interconnection.
- 6 The **OUTPUT LEVEL** meter displays the output level of the Ultra-DI PRO in a range from -24 dB to +18 dB.
- 7 Use the **POWER** switch to turn on the BEHRINGER ULTRA-DI PRO.

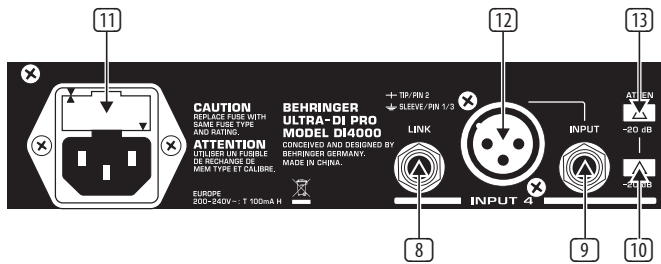

Fig. 1.2: Rear panel elements of the BEHRINGER Ultra-DI PRO

- 8 **LINK.** This is the unbalanced parallel output of the ULTRA-DI PRO. Connect this to the input of the backline or monitor amplifier.
- 9 **INPUT.** Connect the source to this 1/4" jack to input the signal.
- 10 and 13 The **-20 dB ATTENUATION** switches greatly increase the operating range of the ULTRA-DI PRO. From the low level signals of a high impedance guitar to the hot speaker terminals of a PA amplifier. Depressing both will give 40 dB attenuation.

- ◆ Only use the -20 dB switches if you are sure the Ultra-DI PRO is clipping (overloading) and not your mic pre-amp. Always use as little attenuation as possible to get the best possible signal-to-noise ratio.
- 11 **FUSE HOLDER/VOLTAGE SELECTOR.** Please make sure that the voltage indicated on the unit matches your local voltage, before you attempt to connect and operate the VINTAGER AC112. Blown fuses may only be replaced by fuses of the same type and rating. Some models allow for inserting the fuse holder in two different positions, in order to switch over from 230 V to 115 V operation, and vice versa. Please note that for 115 V operation outside Europe, you need to use a fuse of a higher rating (see chapter 3 "Installation"). Use the enclosed power cord to connect the unit to the mains.
- 12 To provide maximum flexibility the ULTRA-DI PRO is also fitted with an unbalanced **XLR INPUT** to connect the source.

2. Applications

2.1 Tapping signal from a (bass) guitar

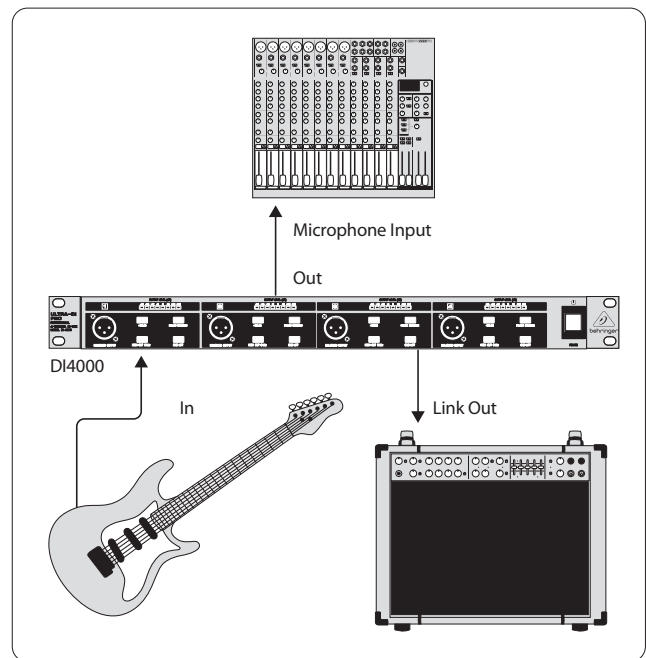

Fig. 2.1: Guitar → DI box → Guitar Amp/Mixer

This figure shows the standard application of any Direct Inject box. The signal to the amplifier is unaffected, it is just tapped off to be routed to the microphone input of the mixer. Especially bass guitars benefit from this application. It is difficult to find a microphone which handles high level low frequencies well and with a linear frequency response. Using the ULTRA-DI PRO will give you clean and crisp sound. Connect the ULTRA-DI PRO after any effects devices, so that their effect will be heard over the PA system or on the recording.

2.2 Converting the output of a keyboard / DJ-mixer / headphone plug

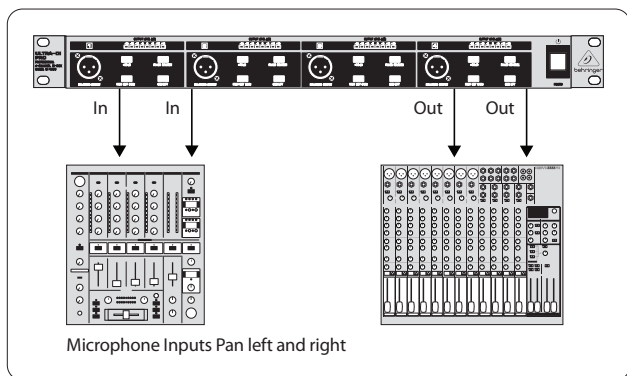

Fig. 2.2: DJ-mixer → 2 x DI box → mixer

This configuration can be used with a keyboard, DJ-mixer, headphone output, drum kit or any (stereo or mono) line source. In all cases where you want to run long lines, for instance to the FOH (Front Of House) desk. The signal can be linked through to another amplifier, if the keyboard player/ DJ/etc. wants to have a monitor connected independent of the foldback mix. The ULTRA-DI PRO acts as both a ground isolator and an unbalanced to balanced converter.

2.3 Converting a microphone signal

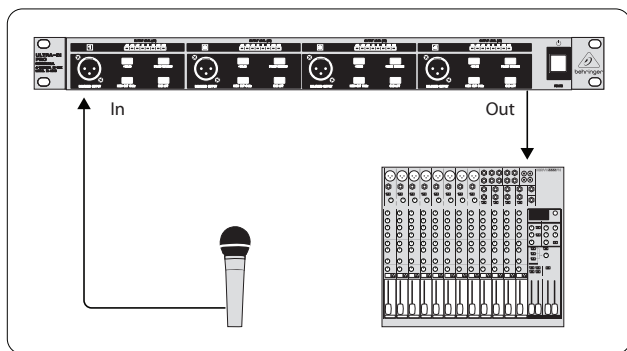

Fig. 2.3: Connecting a microphone

Sometimes all that's available (especially when all other mics are in use) is an unbalanced high impedance microphone with an unbalanced jack. With the ULTRA-DI PRO long cable runs to the console can be established without fear of picking up noise and hum. Just plug the jack into the input and connect the output to the console's mic input.

2.4 Tapping a signal from a power amplifier output

When no line out is available it is possible to connect an amplifier output directly to the DI4000 (for example, recording direct from a guitar amplifier, TV-speaker, etc). It is possible to connect the output, i.e. an extra speaker output, of up to 3000 Watts to the ULTRA-DI PRO without fear of overloading. Pay attention to the two -20 dB buttons on the ULTRA-DI PRO! Both must be depressed if an amplifier output is connected to the DI4000 input.

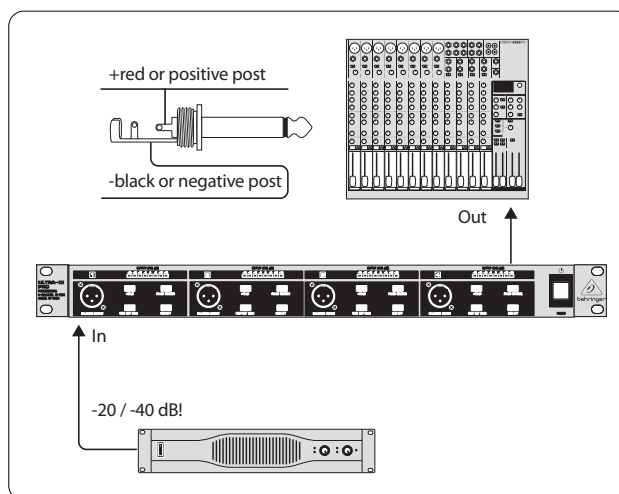

Fig. 2.4: Connection to an amplifier output

- ◆ Always make sure the **GROUND LIFT** is on (no ground link) when connecting to speaker terminals. This prevents accidental short-circuiting of the amplifier output. Also make sure the tip of the input jack is connected to the red terminal and that the metal housing of the DI4000 has no contact with other equipment.

3. Installation

Your BEHRINGER ULTRA-DI PRO was carefully packed in the factory and the packaging was designed to protect the unit from rough handling. Nevertheless, we recommend that you carefully examine the packaging and its contents for any signs of physical damage, which may have occurred in transit.

- ◆ If the unit is damaged, please do not return it to us, but notify your dealer and the shipping company immediately, otherwise claims for damage or replacement may not be granted. Shipping claims must be made by the consignee.

3.1 Rack mounting

The BEHRINGER ULTRA-DI PRO fits into one standard 19" rack unit of space. Please allow at least an additional 4" depth for the connectors on the back panel.

- ◆ Be sure that there is enough air space around the unit for cooling and please do not place the ULTRA-DI PRO on high temperature devices such as power amplifiers etc. to avoid overheating.

3.2 Mains connection

The mains connection of the ULTRA-DI PRO is made by using a mains cable and a standard IEC receptacle. It meets all of the international safety certification requirements.

- ◆ Please make sure that all units have a proper ground connection. For your own safety, it is advisable not to remove the ground connection within the units or at the supply, or fail to make this connection at all.

EN

Before you switch on the unit, check that it is configured to match your AC mains voltage requirements. If it does not comply, then it is necessary to switch the operating voltage to the correct supply requirements BEFORE turning on the unit, otherwise the unit could be severely damaged. You will find this combined fuse holder/voltage selector at the back, adjacent to the IEC receptacle. **IMPORTANT: This does not apply for general export models which are built for one operating voltage only.**

The AC voltage selection is defined by the position of the fuse holder. If you intend to change the operating voltage, remove the fuse holder and twist it by 180 degrees before you reinsert it. Matching the two markers shows the selected voltage.

♦ If the unit is switched to another operating voltage, the fuse rating must be changed. See the technical specifications in the appendix.

A safety fuse protects the unit from serious defects. If the fuse blows, this is a warning sign and always indicates that the circuit is overloaded. The fault must always be repaired before the fuse is replaced. If the safety fuse is faulty and

needs replacing after the unit is repaired, please make sure that you replace it only with the identical type and rating. NEVER use fuses of different ratings or cover faulty fuses with aluminium foil. This can cause fire and electric shocks and will endanger your life and the lives of others.

3.3 Audio connections

As standard, the BEHRINGER ULTRA-DI PRO is installed with transformer-balanced outputs. This transformer features automatic hum and noise reduction for balanced signals and thus allows for trouble-free operation, even at high operating levels. Externally induced mains hum etc. will be effectively suppressed.

♦ Please ensure that only qualified persons install and operate the ULTRA-DI PRO. During installation and operation the user must have sufficient electrical contact to earth. Electrostatic charges might affect the operation of the ULTRA-DI PRO!

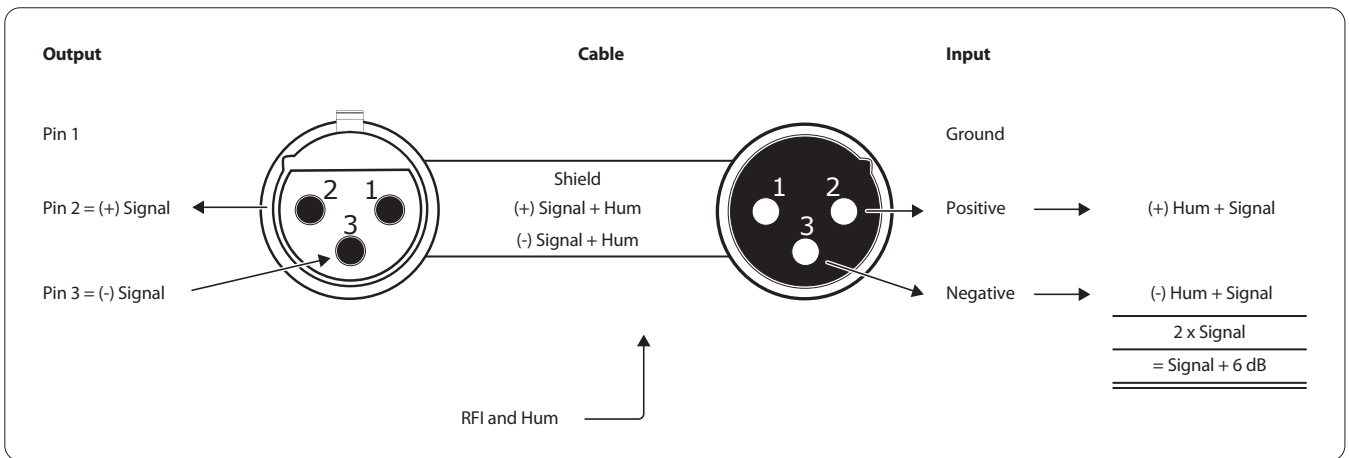
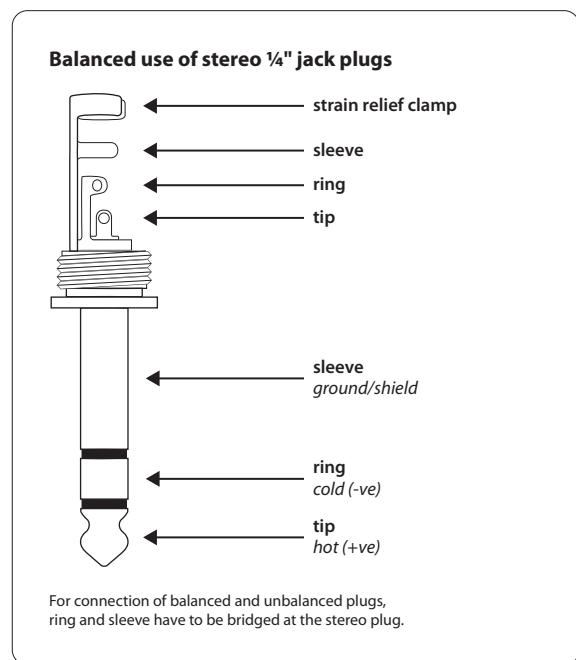
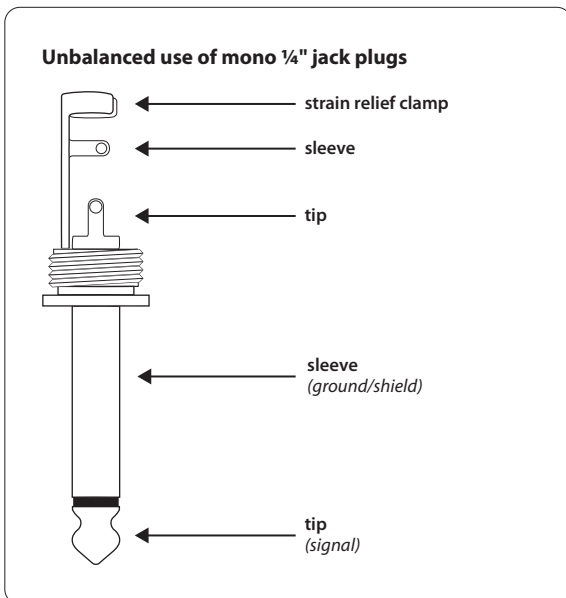

Fig. 3.1: Compensation of interference with balanced connections



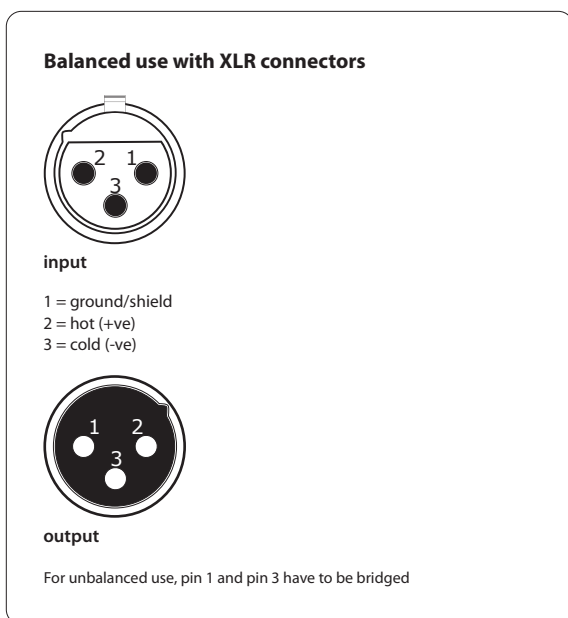

Fig. 3.2: Different plug types

4. Specifications

Audio Input

Connectors	XLR and ¼" jack
Type	DC-decoupled, unbalanced input
Impedance	max. 220 kOhm
Max. input level	+20/+40/+60 dBu

Audio Output

Connectors	XLR
Type	transformer-balanced output stage
Impedance	600 Ohms balanced
Max. output level	+20 dBu

System Specifications

Bandwidth (100 kOhm)	23 Hz to 120 kHz (± 3 dB)
Bandwidth (600 Ohm)	23 Hz to 27 kHz (± 3 dB)
Bandwidth (High Cut)	10 Hz to 8 kHz (± 3 dB)
Noise	-95 dBu

Power Supply

Mains Voltages

USA/Canada	120 V~, 60 Hz
U.K./Australia	240 V~, 50 Hz
Europe	230 V~, 50 Hz
General export model	100 - 120 V~, 200 - 240 V~, 50 - 60 Hz
Power consumption	max. 10 Watts
Fuse	100 - 120 V~: T 200 mA H 200 - 240 V~: T 100 mA H
Mains connection	standard IEC receptacle

Physical

Dimension	1 ¾ x 19 x 8 ½" 44.5 x 482.6 x 215 mm
Net weight	5.9 lbs / 2.7 kg
Shipping weight	7.7 lbs / 3.5 kg

BEHRINGER is constantly striving to maintain the highest professional standards. As a result of these efforts, modifications may be made from time to time to existing products without prior notice. Specifications and appearance may differ from those listed or illustrated.



We Hear You