

SCAG[®]

POWER EQUIPMENT

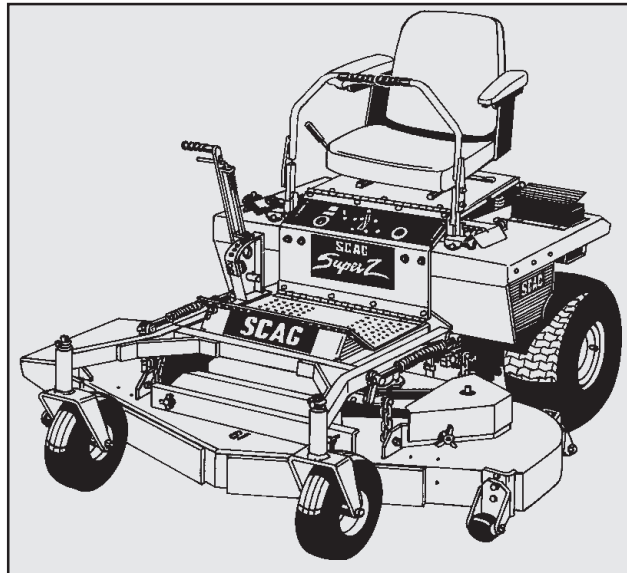

MODEL SSZ



THIS MANUAL CONTAINS THE OPERATING INSTRUCTIONS AND SAFETY INFORMATION FOR YOUR SCAG MOWER. READING THIS MANUAL CAN PROVIDE YOU WITH ASSISTANCE IN MAINTENANCE AND ADJUSTMENT PROCEDURES TO KEEP YOUR MOWER PERFORMING TO MAXIMUM EFFICIENCY. THE SPECIFIC MODELS THAT THIS BOOK COVERS ARE CONTAINED ON THE INSIDE COVER. BEFORE OPERATING YOUR MACHINE, PLEASE READ ALL THE INFORMATION ENCLOSED.

OPERATOR'S MANUAL



WARNING:

FAILURE TO FOLLOW SAFE OPERATING PRACTICES MAY RESULT IN SERIOUS INJURY.

- * Keep all shields in place, especially the grass discharge chute.
- * Before performing any maintenance or service, stop the machine and remove the spark plug wire and ignition key.
- * If a mechanism becomes clogged, stop the engine before cleaning.
- * Keep hands, feet and clothing away from power-driven parts.
- * Read this manual completely as well as other manuals that came with your mower.

REMEMBER - YOUR MOWER IS ONLY AS SAFE AS THE OPERATOR!

Hazard control and accident prevention are dependent upon the awareness, concern, prudence, and proper training of the personnel involved in the operation, transport, maintenance, and storage of the equipment.

This manual covers the operating instructions
and illustrated parts list for:

SSZ-18CV-48	with a serial number of 4200001-4209999
SSZ-22CV	with a serial number of 4230001-4239999
SMZ-48	with a serial number of 4210001-4219999
SMZ-52	with a serial number of 4240001-4249999
SMZ-61	with a serial number of 4250001-4259999

Always use the entire serial number listed on the serial number tag when referring to this product.

SCAG[®]

POWER EQUIPMENT

TABLE OF CONTENTS

SUBJECT	PAGE
General Safety Instructions	1-3
Safety Instructions	1-2
Hydraulic Safety	3
Adjustments	3-6
Neutral Adjustment	3-4
Straight Line Running Adjustment	4-5
Cutter Deck Drive Belts	5
Drive Belt Replacement	6
.....	
Initial Run, Inspection, And Operating Instructions	6-8
Maintenance	8-9
Free Wheeling	8
Cutter Blades	8
Curb Climbing	9
Cutter Deck Adjustment	9
Lubrication & Maintenance Chart	10
Troubleshooting Cutting Conditions	11-13
Specifications For Scag SSZ Zero-Turn Rider	14-15



TABLE OF CONTENTS

(CONTINUED)

SUBJECT	PAGE
Illustrated Parts List	16-35
SMZ-48", 52", 61", Cutter Decks	16-17
Cutter Deck Controls 48", 52", & 61" Decks	18-19
Sheet Metal Components	20-21
Hydraulic Components	22-23
BDU-10L Hydraulic Pump	24
Hydro-Gear Axle Assembly	25
Traction Drive Components	26-27
Brake And Steering Controls	28-29
Instrument Panel And Electrical Components	30-31
Wiring Diagram-Kohler Adapter	32
Wire Harness With Relay	32
Wire Harness, Main	33
Replacement Decals	34-36
Warranty Statement.....	Inside Back Cover

Your mower was built to the highest standards in the industry. However, your mower is only as safe as you, the operator, make it. Carelessness or error on the part of the operator may result in serious bodily injury. Hazard control and accident prevention depend upon the awareness, concern, prudence, and proper training of the personnel involved in the operation, transport, and storage of this equipment. Make sure every operator is properly trained and thoroughly familiar with all of the controls and safety instructions before operating the equipment.

SAFETY INSTRUCTIONS

WARNING:

Do not operate the mower on steep slopes. Riding lawn mowers can tip over when used on an excessive slope. To check a slope, attempt to back up with the cutter deck down. If the wheels slip when backing up a slope, stay off the slope. If you are in doubt about hillside operation, stay off the slope.

Always back up when loading a machine on ramps or tilt bed trailers.

1. Know the controls and how to stop quickly. READ THIS OPERATOR'S MANUAL and instructions furnished with any attachments. A replacement Operator's Manual is available from your Scag Servicing Dealer. To order, contact your dealer with the complete model number and serial number of your Scag product.
2. Do not allow children to operate this machine. Do not allow adults to operate this machine without proper instruction.
3. Do not carry passengers. Never mow toward or near anyone.
4. Clear the area of objects such as wires, sticks, and rocks that can be picked up and thrown by the mower blades.
5. Disengage all attachment clutches and engage the parking brake before attempting to start the engine.
6. Disengage all attachment clutches and engage the parking brake before leaving the operator's position.
7. Disengage the power to attachments, stop the engine, and remove the key before making any repairs or adjustments.
8. Disengage the power to attachments when transporting the machine or when attachments are not being used.
9. Take all possible precautions when leaving the machine unattended including disengaging the power to attachments, lowering the attachments, setting the parking brake, and removing the key.
10. Do not stop or start suddenly when going up or down a hill. Mow up and down the face of slopes; never mow across slopes.
11. Reduce speed and be very careful when operating on slopes or making sharp turns to prevent tipping or loss of control. Be especially cautious when changing direction on slopes. If necessary to turn on a hill, always turn downhill.
12. Watch for holes, rocks, roots in the terrain, and other hidden hazards. Keep away from dropoffs.
13. Watch for traffic when crossing roadways or operating near roadways.
14. When using any attachments, never directly discharge materials towards bystanders or allow anyone near the mower while it is operating.
15. Handle gasoline with care - it is highly flammable.
 - a. Use an approved gasoline container only.
 - b. Never remove the fuel cap while the engine is running or hot. Allow the engine to cool for several minutes before removing the cap and adding gasoline. Never fill the fuel tank indoors. Always clean up spilled gasoline.
 - c. Do not run the engine indoors.

SAFETY INSTRUCTIONS - CONT'D

16. Keep the machine and attachments in good operating condition. Make sure all safety devices and shields are in place and operate the equipment as intended.
17. Keep all nuts, bolts, and screws tight to be sure equipment is in safe operating condition.
18. Never store the equipment with gasoline in the tank in a building where fumes may reach an open flame or spark. Allow the engine to cool before storing the machine in any enclosure.
19. To reduce fire hazard, keep the engine free of grass, leaves, or excess lubricants.
20. If the machine or attachments strike a foreign object, disengage the power to the attachments and stop the engine immediately. Wait for all moving parts to stop, then inspect for damage. Repair the damage before restarting or operating the equipment.
21. Do not change the engine governor settings or overspeed the engine.
22. When using the machine with a mower:
 - a. Mow only in daylight or good artificial light.
 - b. Never dismount the machine to adjust the cutting height while the engine is running.
 - c. Shut the engine off and remove the key before removing the grass catcher or unclogging the chute.
 - d. Check the blade mounting bolts frequently for proper tightness.
23. Disengage the power to the blades before backing up. Do not mow in reverse unless absolutely necessary and then only after careful observation of the entire area behind the mower.
24. The discharge chute must be installed and be in the down position on a side discharge mower except when the optional grass catcher or the mulching plate is completely installed. If the discharge chute clogs, shut the engine off, remove the key, and wait for all movement to stop before removing any obstruction.
25. Perform only the maintenance described in this manual. If additional maintenance or major repairs are needed, contact an authorized Scag Servicing Dealer. To ensure optimum performance and safety, always purchase genuine Scag replacement parts and accessories. Never use "WILL FIT" replacement parts and accessories made by another manufacturer. Using such parts may void the warranty.

WARNING:

Do not operate the machine while wearing sandals, tennis shoes, sneakers, or shorts. Also, do not wear loose fitting clothing which could get caught in moving parts. Always wear long pants and substantial shoes. Wearing safety glasses and safety shoes is advisable.

CAUTION:

Stop the engine and remove the key from the ignition before making any adjustments. Wait for all moving parts to come to a complete stop before beginning work.

Engine and drive unit can get hot during operation. Allow the engine and drive components to cool before making any adjustments.

WARNING:

To prevent personal injury or equipment damage, do not operate the machine without the cutter deck properly mounted.

HYDRAULIC SAFETY

1. Hydraulic fluid is under high pressure. If you need service on your hydraulic system, please see your dealer.

WARNING:

Keep your body and hands away from pin holes or nozzles that eject fluid under high pressure. Use paper or cardboard, not hands, to search for leaks.

Hydraulic fluid escaping under high pressure may have sufficient force to penetrate your skin and cause serious injury. If fluid is injected into your skin, a physician familiar with this form of injury must remove it surgically within a few hours or gangrene may result.

2. Make sure all hydraulic fluid connections are tight and all hoses and lines are in good condition before applying pressure to the system.

ADJUSTMENTS

Neutral Adjustment

1. Set the machine up on jack stands so the drive wheels are free to rotate. Block the caster wheels to prevent an accident if the machine should accidentally fall off the jack stands.
2. **Run Position:** Move the dump valve lever (on the Left Hand side of mower) behind the hook on the frame to close the hydraulic dump valves on the pump. (See Figure 1)

Free Wheel Position: Pull lever back and to the left, then push forward to relieve pressure. (See Figure 1)

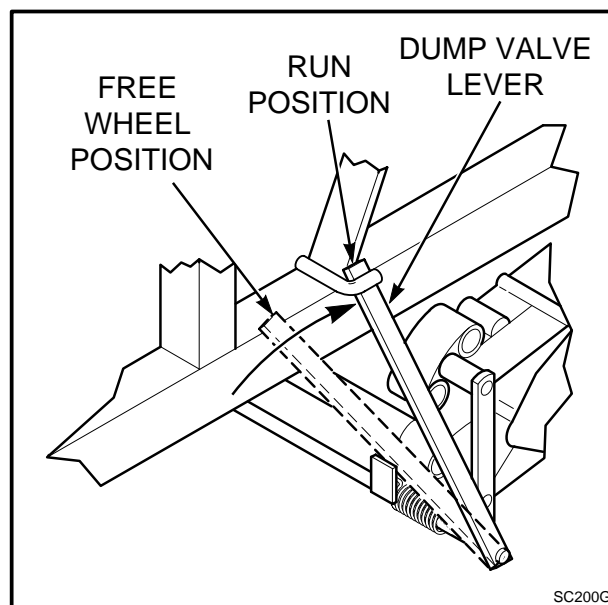

Figure 1

3. Start the engine and check if one or both of the drive wheels are turning.
4. Adjust each drive wheel separately by using the turnbuckles located under the seat. Loosen the jam nut on the turnbuckle. (See Figure 2)
5. If the drive wheel is rotating forward, adjust the turnbuckle clockwise. If the drive wheel is rotating rearward, adjust the turnbuckle counterclockwise. Adjust until the drive wheel stops turning. (See Figure 2)

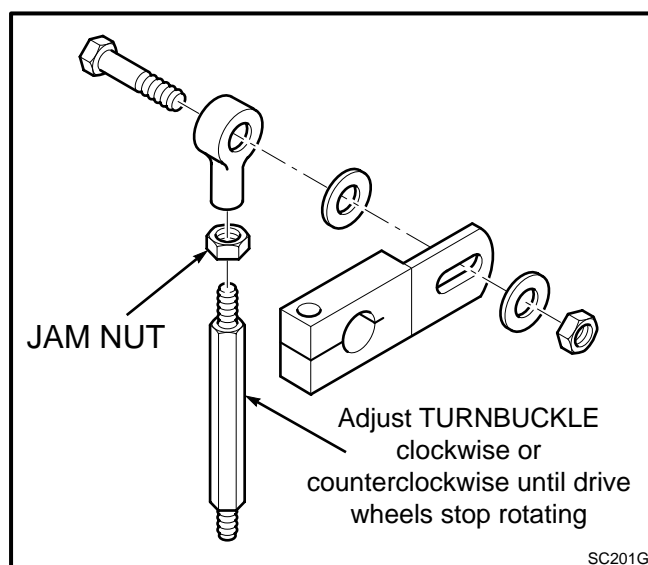

Figure 2

ADJUSTMENTS - CONT'D

Neutral Adjustment Cont'd

6. Tighten both the jam nuts to secure the **neutral** position.
7. Adjust the other drive wheel if necessary.
8. Actuate the hand control levers forward and reverse. Allow the levers to self-center and check that the drive wheels remain in neutral.

NOTE: The neutral return mechanisms on the fenders are adjusted at the factory. Readjustment should not be necessary.

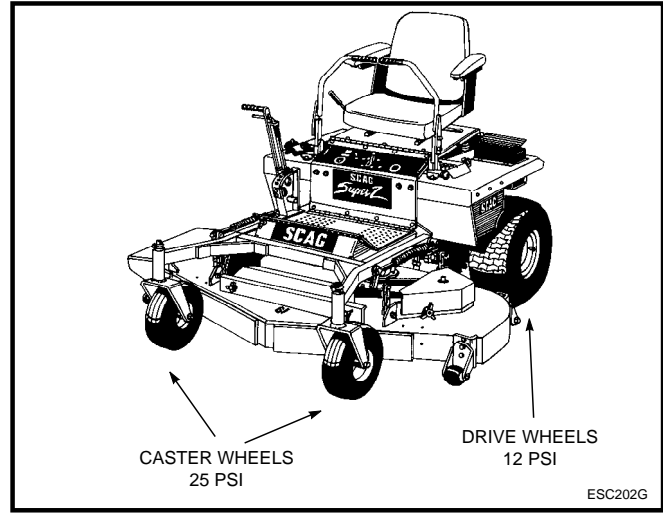

Figure 3

Straight Line Running Adjustment



CAUTION:

Stop the engine and remove the key from the ignition before making any adjustments. Wait for all moving parts to come to a complete stop before beginning work.

The engine and drive unit can get hot during operation. Allow engine and drive components to cool before making any adjustments.

1. Before making this adjustment, check the tire pressure of the drive wheels. Tire pressure for each wheel must be equal. (See Figure 3) If the tire pressures are not equal, the machine will pull to the side with the lower tire pressure.

NOTE: Make this adjustment only on the LH pump. The RH pump has a fixed speed and cannot be adjusted.

2. Locate the turnbuckle for LH pump under the operator seat in front of the hydraulic oil tank. (See Figure 4)
3. Loosen nut securing the turnbuckle to bellcrank. (See Figure 4)

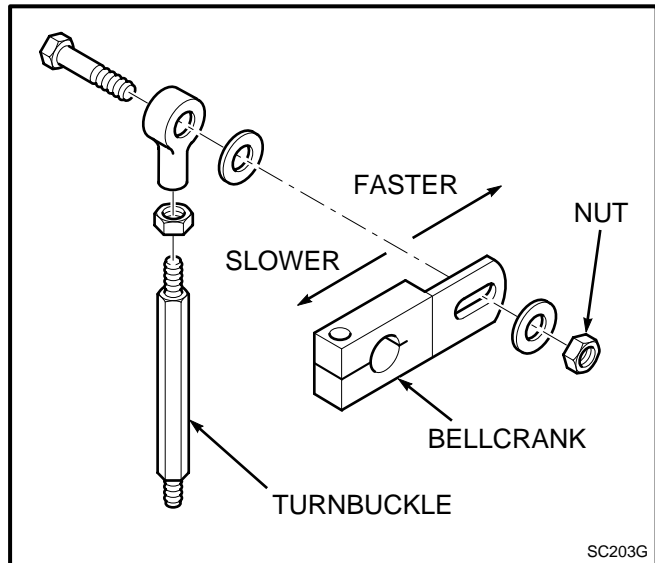

Figure 4

ADJUSTMENTS - CONT'D

Straight Line Running Adj. - Cont'd

4. Adjust the position of the turnbuckle by moving it in the mounting slot either forward to slow the left wheel or backward to speed up the left wheel. If the unit pulls to the right, the left wheel is too fast. If the unit pulls to the left, the left wheel is too slow.
5. Tighten the jam nut to secure the turnbuckle.
6. Readjust neutral if necessary. (See Figure 2)

Cutter Deck Drive Belts

⚠ CAUTION:

Stop the engine and remove the key from the ignition before making any adjustments. Wait for all moving parts to come to a complete stop before beginning work.

1. Lift the foot plate and secure with the foot plate support rod.
2. To adjust the cutter deck drive belt: Adjust until the end of the spring aligns with the end of L-shaped bracket. (See Figure 5)

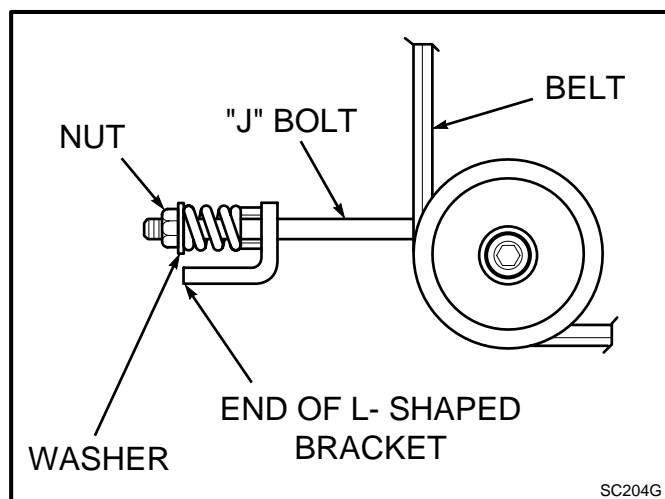

Figure 5

NOTE: Due to initial belt stretching, check this adjustment after the first 2 , 4 , and 8 hour intervals.

3. To adjust the RH blade drive belt: Adjust the RH belt tension so the belt moves 1/2" with 10 pounds pressure. Adjust the tension by tightening or loosening the J-bolt. (See Figure 6 for SMZ-52; See Figure 7 for SMZ-61 & SMZ-48)
4. Carefully unlatch foot plate support rod and lower foot plate.

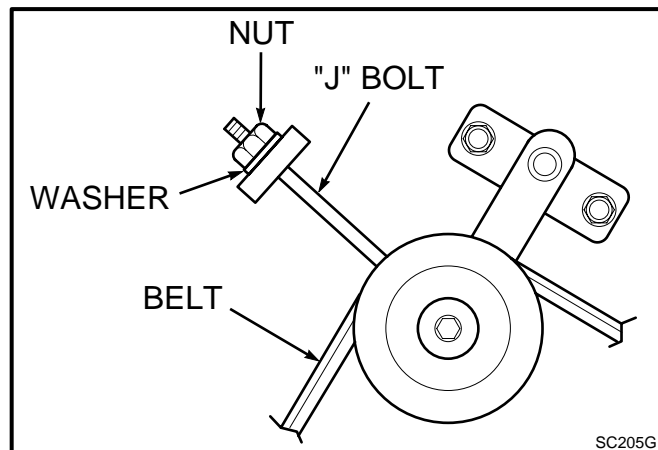

Figure 6 - SMZ-52

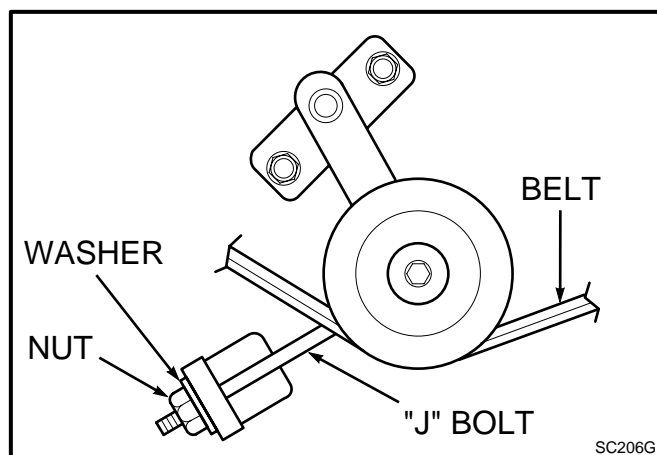

Figure 7 - SMZ-61 & SMZ-48

ADJUSTMENTS - CONT'D

Drive Belt Replacement



CAUTION:

When replacing the drive system belt use extreme caution. The idler arm is under spring tension.

Remove the two 1/4" nuts on the belt guard and remove the guard. To remove the old belt, use a 1/2" drive breaker bar and insert it into the square hole on the idler arm. Pull the idler arm down until the belt becomes slack and can be removed easily from the idler pulley. Slowly move the idler arm up until the stop bolt rests against the hydraulic tank support. Remove the old belt and mount the new belt around the engine drive pulley and the two pump pulleys. Feed the belt up toward the idler pulley.

Pull the idler arm down so that the new belt can easily be mounted on the idler pulley. Slowly move the idler arm up until the belt is firmly engaged. Remove the breaker bar and remount the belt guard. Check to ensure that the belt is riding properly in all pulleys.

Hand Control Handle Position

The position of the hand control handles can be adjusted for operator comfort. Loosen the bolts holding the handle to the lever bar just enough to allow movement of the handle. Adjust to position most comfortable for operator. Retighten the bolts.

INITIAL RUN, INSPECTION, AND OPERATING INSTRUCTIONS

1. Check that all belts are routed correctly and aligned properly.
2. Check the cutter blade drive belts for correct tension.

3. Make sure the engine oil level (10W30) is at FULL on the dipstick. When performing oil changes, fill the engine to the full mark on the engine dipstick. (Approximately 2 quarts will be needed for Kohler engines) DO NOT OVERFILL.
4. Check the oil level (SAE 20W50) in the hydraulic reservoir. The reservoir is under the seat. The oil level should be 2" below the top of the tank. When performing oil changes, fill the reservoir until it is 2" below top of tank. (Approximately 4 quarts will be needed) DO NOT OVERFILL.
5. Check that all fasteners are tightened properly. Make sure all safety devices are in place and working correctly.



WARNING:

Gasoline is highly flammable. Be careful when filling the tank. Do not fill the tank while the engine is running or hot from operation. Extinguish open flames, matches, and smoking materials before filling the tank. Do not overfill the tank. Wipe up all gasoline spills.

6. Fill the fuel tank with clean, fresh, lead-free gasoline with a minimum octane rating of 87.
7. Check the safety interlock system. With the operator on the seat, the engine must not start unless the control handles are in the neutral lock position and the cutter drive is disengaged.

IMPORTANT: If the engine is running, the engine must stop if the operator leaves the seat when one or both handles are in the drive position or the cutter drive is engaged.

INITIAL RUN, INSPECTION, AND OPERATING INSTRUCTIONS - CONT'D

8. To start the engine:
 - a. Place the control handles in the neutral lock position.
 - b. Push the mower engagement switch to the off position.
 - c. Put the parking brake in the engaged position.
 - d. Adjust the throttle and choke as required.
 - e. Turn the ignition key to start. Release the ignition key when the engine starts. The key will return to the RUN position.

9. Pull the yellow engagement switch out to engage the cutter drive belts. (See Figure 8) Allow the belts to run for five minutes.

NOTE: For best belt life, engage the clutch at 3/4 speed and not under load.

NOTE: When the PTO is engaged (or possibly disengaged), a squealing sound from the under side of the machine is normal. It is caused by the electric clutch plates meshing as the mower comes up to speed.

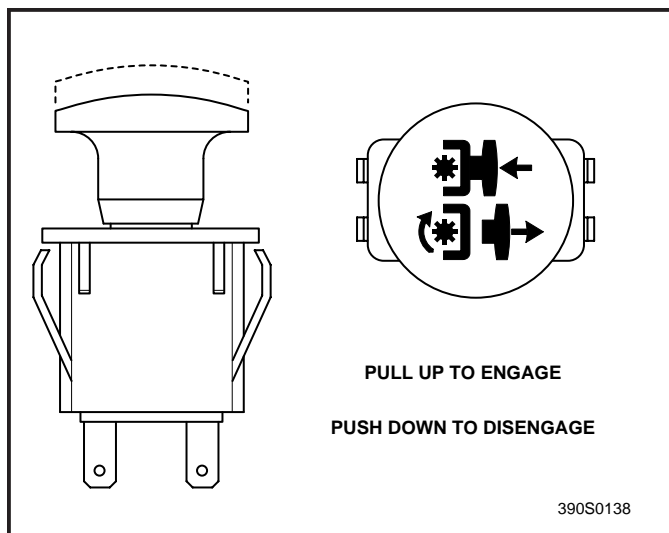

Figure 8

10. Release the parking brake. Check that the machine does not creep forward or backward. If the machine does creep, adjust the neutral control. See “Neutral Adjustment” instructions.

CAUTION:

CAUTION: Stop the engine and remove the key from the ignition before making any adjustments. Wait for all moving parts to come to a complete stop before beginning work.

The engine and drive unit can get hot during operation. Allow the engine and drive components to cool before making any adjustments.

11. Operate the machine forward and backward. Check that all the systems function correctly. If the machine does not move, make sure the hydraulic dump valve lever near the left wheel is engaged. (See Figure 1 page3)

To engage the parking brake, move the lever up and out into the bracket. To disengage the parking brake, pull the lever up and in, away from the bracket. (See Figure 9)

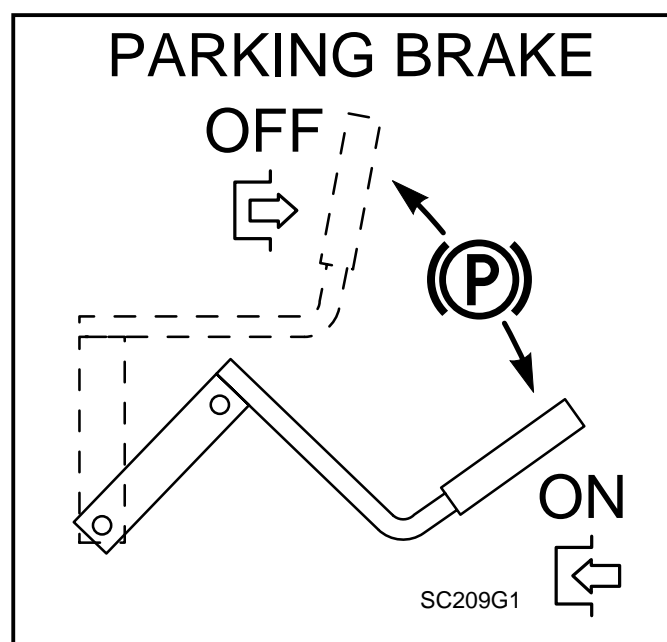

Figure 9

INITIAL RUN, INSPECTION, AND OPERATING INSTRUCTIONS - CONT'D

12. Shut off the engine, remove the key from the ignition, and wait for all moving parts to stop. Recheck the cutter deck drive belts for proper tension. Correct and adjust as necessary.
13. Park the machine on a level area, set the parking brake, and remove the key from the ignition to prevent engine starting.
14. Before transporting the machine, latch the seat stop cable to avoid damage to the seat.

MAINTENANCE

Free Wheeling

To release the drive wheels, so the machine will roll without the engine running, pull the dump valve lever back from the hook on the frame, move it to the left, and push it forward to relieve the pump pressure. The lever is on the LH side of the machine. (See Figure 1 on page 3)

Cutter Blades

WARNING:

The blade is sharp! A blade at rest can cause severe cuts. Rotating the blade can cut fingers off. Always lift deck using handles provided.

Sharpen the blades as shown on Figures 10 and 11.

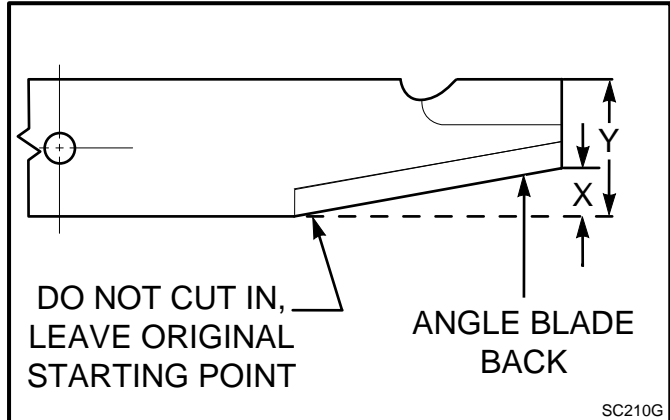

Figure 10

Do not sharpen (X) beyond 1/3 of blade width (Y).

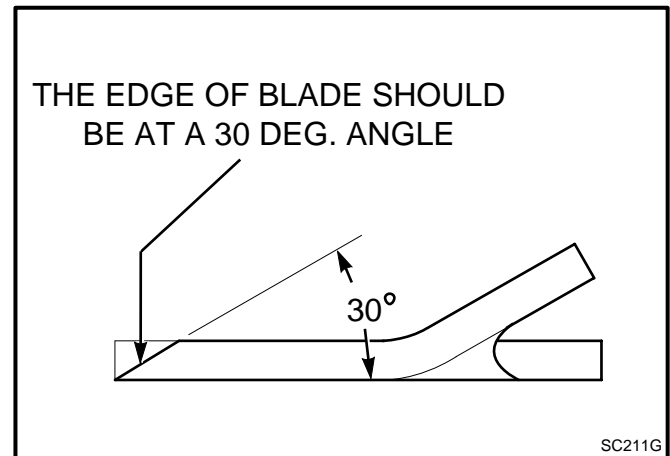

Figure 11

Suggestion: Dress the blade with a file. Wheel grinders may burn the blade.

MAINTENANCE - CONT'D

Curb Climbing

When driving a riding mower up and over a curb, first raise the cutter deck to the highest position. Then, drive it in reverse and at an angle so that the back drive wheels go over the curb one at a time. When both drive wheels are over the curb, turn the machine so that both front caster wheels contact the curb at the same time. (See Figure 12)

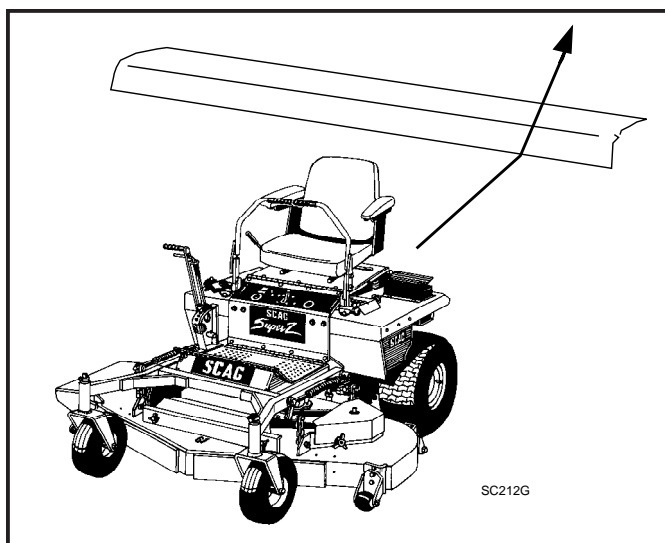

Figure 12

Cutter Deck Adjustment

Poor cutting performance of your Scag SSZ can be an indication that your cutter deck may need to be adjusted. If you have checked that your blades are properly sharpened and not bent please take your machine to an authorised Scag servicing dealer for proper repairs.

For assistance in troubleshooting cutting performance conditions please see pages 11-13.

LUBRICATION & MAINTENANCE

Break-In			
	8 hours (Daily)		
	40 hours (Weekly)		
	100 hours (Biweekly)		
	200 hours (Monthly)		
X		Procedure	Comments
X		Check all hardware for proper tightness Change engine oil and filter at 5 hours Check belt tension	See engine manufacturer information 2 hour, 4 hour, and 8 hour intervals.
X		Check engine oil level Remove debris from oil cooler Clean hydraulic pump cooling fins Remove debris from under belt cover Sharpen cutter blades Grease spindle bearings (2 pumps of hand gun) Clean air filter Check tire pressure	Do not overfill See engine manufacturer information MORE OFTEN IF NEEDED MORE OFTEN IF NEEDED MORE OFTEN IF NEEDED + US Lithium MP White Grease 2125 MORE OFTEN IF NEEDED Add air if necessary
	X	Check battery acid level Check belt tension	Use distilled water only Adjust as needed.
	X	Replace air filter Change engine oil Grease caster wheel bearings Grease caster wheel pivots Grease idler arm pivots Grease push arms Grease control levers Grease bell crank Grease height adjustment	MORE OFTEN IF NEEDED See engine manufacturer information Chassis grease - Qty 2 Chassis grease - Qty 2 Chassis grease - Qty 3 Chassis grease - Qty 2 Chassis grease - Qty 2 Chassis grease - Qty 4 Chassis grease - Qty 1
	X	Check all hardware for proper tightness Change engine oil filter Check hydraulic fluid reservoir level Clean and adjust spark plugs	See engine manufacturer information Add oil if needed (SAE 20W50) See engine manufacturer information
		Every 500 hours (Bimonthly) Drain hydraulic system and replace fluid Change hydrostatic oil filter * Adjust air gap on electric clutch	Use SAE 20W50 motor oil Clean area before removing filter Contact your Scag dealer for information about making this adjustment

*** IMPORTANT: Use only Scag Authorized part for proper filtration.**

+ Compatible Greases:

Lidok EP #2 (found at industrial shops)

Ronex MP (Exxon service stations)

Shell Alvania (Shell service stations)

Mobilux #2 (Mobil service stations)

Super Lube-M EP #2 and Super Lube-M #2 (Conoco service stations)

TROUBLESHOOTING CUTTING CONDITIONS

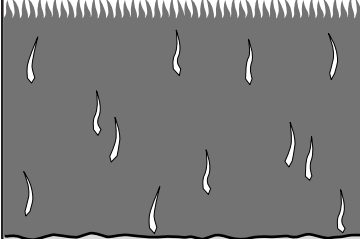
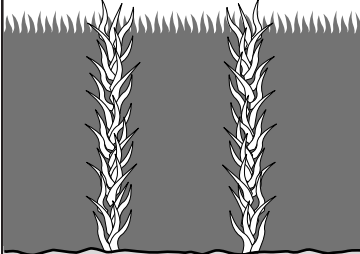
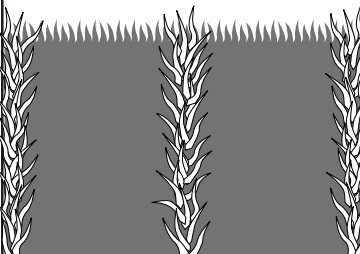
CONDITION	CAUSE	CURE
<p>Stringers - Occasional Blades of Uncut Grass</p>  <p style="text-align: center;">Width of Deck</p> <p style="text-align: right; font-size: small;">SGB020</p>	Low engine RPM	Run engine at full 3600 RPM
	Ground speed too fast	Slow speed to adjust for conditions
	Wet grass	Cut grass after it has dried out
	Dull blades, incorrect sharpening	Sharpen blades
	Deck plugged, grass accumulation	Clean underside of deck
	Belts slipping	Adjust belt tensions
<p>Streaking - Strips of Uncut Grass in Cutting Path</p>  <p style="text-align: center;">Width of Deck</p> <p style="text-align: right; font-size: small;">SGB018</p>	Dull, worn blades	Sharpen blades
	Incorrect blade sharpening	Sharpen blades
	Low engine RPM	Run engine at full 3600 RPM
	Belt slipping	Adjust belt tension
	Deck plugged, grass accumulation	Clean underside of deck
	Ground speed too fast	Slow speed to adjust for conditions
	Wet grass	Cut grass after it has dried out
	Bent blades	Replace blades
<p>Streaking - Strips of Uncut Grass Between Cutting Paths</p>  <p style="text-align: center;">Width of Deck Width of Deck</p> <p style="text-align: center; font-size: small;">SGB019</p>	Not enough overlapping between rows	Increase the overlap of each pass

TROUBLESHOOTING

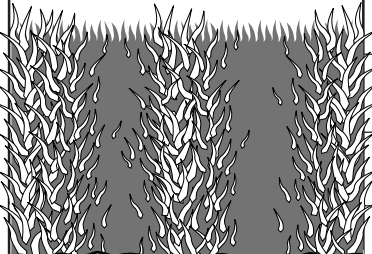
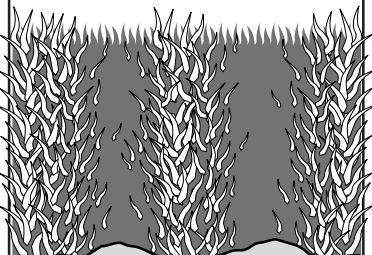
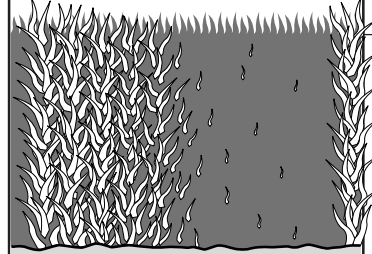
CONDITION	CAUSE	CURE
<p data-bbox="99 373 373 583">Uneven Cut on Flat Ground - Wavy High-Low Appearance, Scalloped Cut, or Rough Contour</p>  <p data-bbox="180 877 347 905">Width of Deck</p> <p data-bbox="375 930 435 947">SGB020</p>	Lift worn off of blade	Replace blade
	Blade upside down	Mount with cutting edge toward ground
	Deck plugged, grass accumulation	Clean underside of deck
	Too much blade angle (deck pitch)	Adjust pitch and level
	Deck mounted improperly	See your authorized SCAG dealer
	Bent spindle area	See your authorized SCAG dealer
	Dull blade	Sharpen blade
<p data-bbox="99 976 418 1150">Uneven Cut on Uneven Ground - Wavy Appearance, High-Low Scalloped Cut, or Rough Contour</p>  <p data-bbox="180 1459 347 1486">Width of Deck</p> <p data-bbox="375 1512 435 1528">SGB021</p>	Uneven ground	May need to reduce ground speed, raise cutting height, and/or change direction of cut
<p data-bbox="99 1556 407 1625">Sloping Ridge Across Width of Cutting Path</p>  <p data-bbox="180 1913 347 1940">Width of Deck</p> <p data-bbox="375 1965 435 1982">SGB023</p>	Tire pressures not equal	Check and adjust tire pressure
	Wheels uneven	Check and adjust tire pressure
	Deck mounted incorrectly	See your authorized SCAG dealer

TROUBLESHOOTING

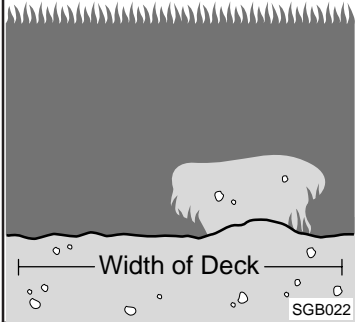
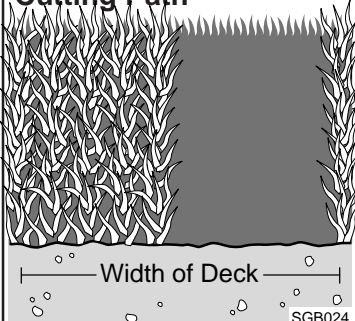
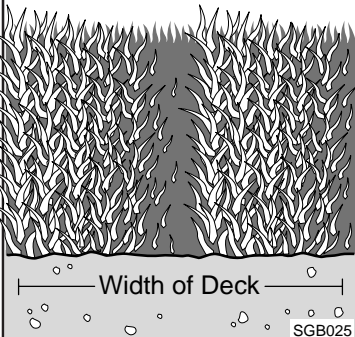
CONDITION	CAUSE	CURE
<p>Scalping - Blades Hitting Dirt or Cutting Very Close to the Ground</p>  <p style="text-align: right; font-size: small;">SGB022</p>	Low tire pressures	Check and adjust pressures
	Ground speed too fast	Slow speed to adjust for conditions
	Cutting too low	May need to reduce ground speed, raise cutting height, change direction of cut, and/or change pitch and level
	Rough terrain	May need to reduce ground speed, raise cutting height, and/or change direction of cut
	Ground speed too fast	Slow speed to adjust for conditions
	Wet grass	Cut grass after it has dried out
<p>Step Cut Ridge in Center of Cutting Path</p>  <p style="text-align: right; font-size: small;">SGB024</p>	Blades not mounted evenly	Adjust pitch and level
	Bent blade	Replace blade
	Internal spindle failure	See your authorized SCAG dealer
	Mounting of spindle incorrect	See your authorized SCAG dealer
<p>Slope Cut - Sloping Ridges Across Width of Cutting Path</p>  <p style="text-align: right; font-size: small;">SGB025</p>	Bent spindle mounting area	See your authorized SCAG dealer
	Internal spindle failure	See your authorized SCAG dealer
	Bent deck housing	See your authorized SCAG dealer



SPECIFICATIONS FOR SCAG SSZ ZERO-TURN RIDER

MODELS:SSZ-18CV, SSZ-22CV

ENGINE

General Type:	Heavy duty industrial/commercial
Brand:	Kohler
Model:	Kohler 18CV, 22CV Command Vertical Engine
Horsepower:	18HP, 22HP @ 3600 RPM
Type:	4 cycle gas, twin cylinder, vertical shaft engine
Displacement:	18HP=624 cc,22HP=674cc
Cylinders:	2 cast-iron sleeves
Governor:	Mechanical type governor with variable speed control set at 3600 rpm (\pm 100rpm), idle set at 1400 rpm
Air Cleaner:	Large capacity dual element, chopper-type grass screen
Exhaust:	Single exhaust canister muffler
Fuel Pump Group:	Mechanical fuel pump with inline fuel filter, fixed jet carburator with Smart- Choke™ and fuel shutdown solenoid
Valve Group:	Kohler-hydraulic valve lifters standard
Starter/Electrical:	12 volt battery with alternator, solid state ignition with key start
Charging System:	15 amp

ENGINE DECK

Fuel Tank:	5 gallon (19.0 litres) seamless polyethylene tank with fuel gauge gas cap
Drive Wheels/Tires:	20x10.0-8 four-ply pneumatic tubeless, radius edge, offset rims to improve operator's view
Parking Brake:	Lever operated integral disc brake
Frame:	Compact tractor frame with structural steel tubing construction

DRIVE SYSTEM

Type:	Hydro drive with two hydrostatic transmissions for independent control of each drive wheel
Hydrostatic Transmissions:	Two Hydro-Gear Model #BDU 10L with integral pump/motor and axle
Transmission Belt Idler:	Self-adjusting, self-tightening
Dump Valve:	Single lever, allows for movement without engine running
Hydro Fluid Cooling Group:	6 qt. capacity nylon fluid reservoir, uses SAE 20W50 fluid and 10 micron filter, fan driven off pump drive belt cools fins on pump/motor transmission
Steering/Travel Control:	Twin lever fingertip steering control with individual control to each wheel
Axles:	1" heavy-duty, heat-treated flanged axle
Wire Harness:	14 gauge wire
Safety Group:	Seat actuated engine kill interlock, mower engagement (BBC) switch
Instrument Panel:	Ammeter, hour meter, key switch, throttle, fuses, manual choke, BBC switch
Forward Speed Range:	0 to 6.8 mph
Reverse Speed Range:	0 to 3.5 mph

Date of Issue: June, 1998
Specifications Subject to Change Without Notice

SPECIFICATIONS FOR SCAG SSZ ZERO-TURN RIDER

MODELS:SSZ-18CV, SSZ-22CV

CUTTER DECK

Type:	SMZ 48, SMZ 52, SMZ 61 Floating, adjustable, anti-scalping, hybrid design combines out-front and belly-mount designs
Construction:	10-gauge steel with 7-gauge (3/16") steel skirt
True Cutting Width:	48.0" (122.0 cm), 52" (132.0 cm), 61: (155.0 cm)
Cutting Height Adjustment:	Hand operated lever adjustment from operator's seat, 1-3/4" to 4-1/2" in 1/2" increments
Cutter Blades:	.204 thick, milled edge, 5150 alloy steel SMZ 48: Three (3) 16.5" blades SMZ 52: Three (3) 18 blades SMZ 61: Three (3) 21" blades
Blade Engagement:	Electric blade engagement clutch with control panel switch
Discharge Opening:	Extra wide 11.5" discharge opening with spring loaded discharge chute
Caster Wheels:	12x 3.5" with quick pin removal
Spindles:	Heavy duty 1-1/8" top dimension spindle shaft, cast housing, taper roller bearing, low maintenance with top access grease fitting and grease overfill relief poppet
Spindle Pulleys:	Cast-iron with easily removed taper hubs
Cutter Deck Belts:	B-section with Kevlar cord

ADDITIONAL SPECIFICATIONS

Seat:	Padded with arm rests
-------	-----------------------

OPTIONAL ITEMS/ATTACHMENTS

Grass Catcher:	Spindle driven GC-SSZ-48 has 48 gallon capacity molded plastic hopper. GC-SSZ-6KH has 6 HP Kohler auxillary engine, 48 gallon capacity molded plastic hopper.
Mulching Plate:	Steel plate fits over discharge opening. No blade change or removal required. Installs and removes in the field.

APPROXIMATE DIMENSIONS

	SMZ 48	SMZ 52	SMZ 61
Length:	72.0"	77.0"	77.0"
Tracking Width:	46.0"	49.0"	49.0"
Width:	59.0"	64.5"	73.5"
Width (with discharge chute up):	49.0"	53.0"	62.0"
Height:	48.0"	51.0"	51.0"
Turning Radius:	zero	zero	zero
Weight:	790 lbs.	835 lbs.	865 lbs.
Weight with GC-SSZ-48:	1060 lbs.		
Width with GC-SSZ-48:	59.0"		
Length with GC-SSZ-48:	78.0"		
Weight with GC-SSZ-6KH:		1055 lbs.	1085 lbs.
Width with GC-SSZ-6KH:		73.5"	82.5"
Length with GC-SSZ-6KH:		83.0"	83.0"

48", 52", & 61" CUTTER DECKS

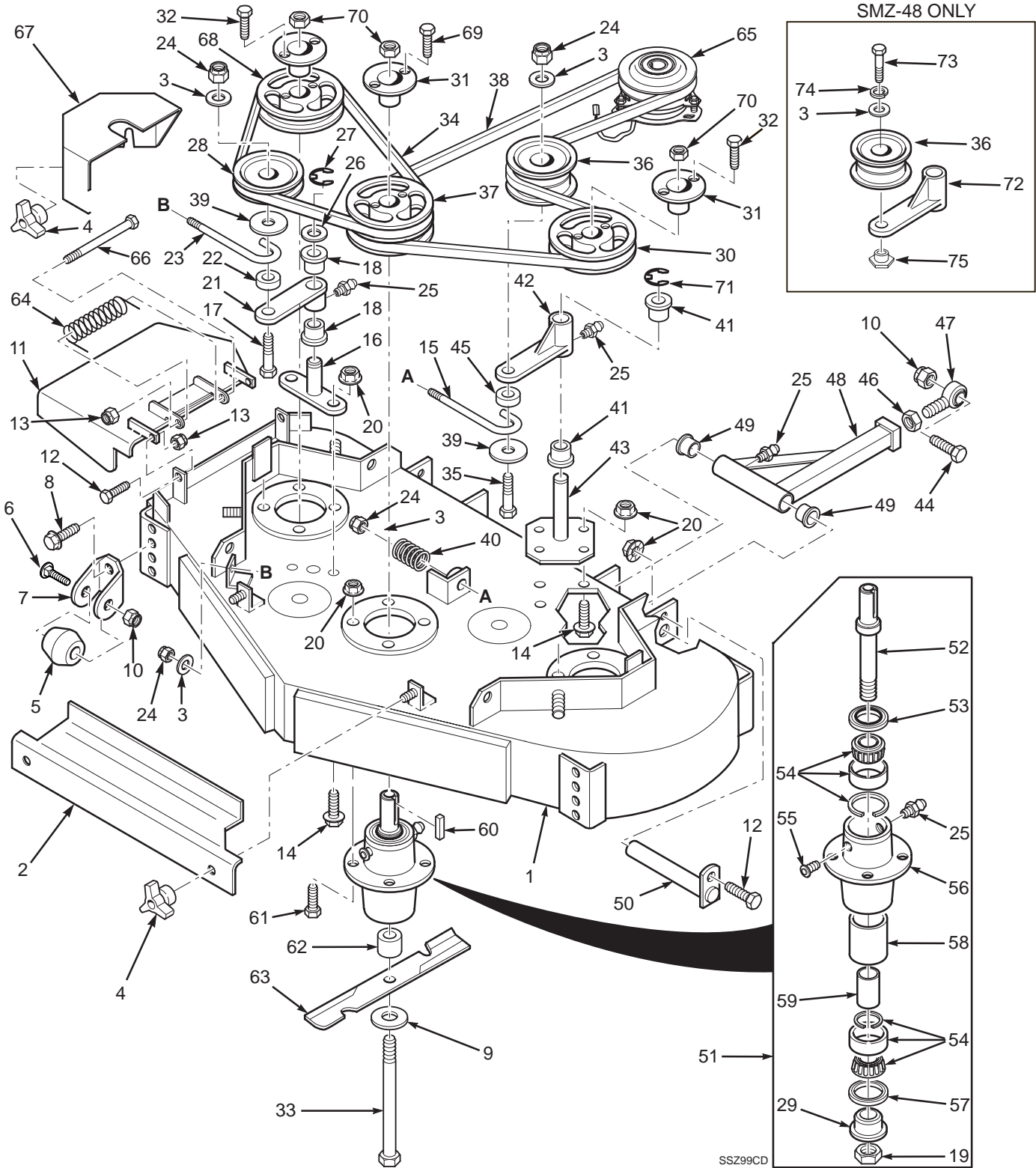

48", 52", & 61" CUTTER DECKS

Ref. Part				Ref. Part				
No.	Number	Description	48 52 61	No.	Number	Description	48 52 61	
1	461133	Cutter Deck (Includes decals)	X		48996	Belt, Blade Drive	X	
	461136	Cutter Deck (Includes decals)	X	39	04041-12	Flatwasher, 3/8" (.375 x 1.5 x .06)	X X X	
	461140	Cutter Deck (Includes decals)	X	40	48807	Spring, Idler Tension	X X X	
2	421058	Belt Cover, Front	X	41	48100-02	Bushing	X X X	
	421451	Belt Cover, Front	X	42	46750	Idler Arm (Includes bushings & grease fittings)	X X	
	421299	Belt Cover, Front	X	43	45329	Idler Pivot Base	X X X	
3	04041-07	Flatwasher, 3/8" Spcl. (.391 x .938 x .105)	X X X	44	04001-97	Bolt, Hex Head 5/8-11 x 3"	X X X	
4	04029-03	Wing Nut, 3/8-16	X X X	45	43282	Spacer	X X	
5	481689	Anti-Scalp Wheel	X	46	04020-16	Nut, Hex 5/8-18 UNF	X X X	
	481632	Anti-Scalp Wheel	X X	47	48763	Rod End	X X X	
6	04003-26	Bolt, carriage 3/8-16 x 4"	X X X	48	461036	Push Arm (Includes 25, 46, 47, and 49)	X X X	
7	422525	Anti-Scalp Wheel Bracket	X	49	48100-06	Bushing	X X X	
8	04017-27	Bolt, Hex Serrated Flange 3/8-16 x 1"	X X X	50	45332	Push Arm Shaft	X X X	
9	04040-10	Flatwasher, 5/8" (.688 x 1.75 x .134)	X X X	51	46631	Spindle Assembly	X X X	
10	04021-05	Nut, Lock 3/8-16 Center Lock	X X X	52	43298	Spindle Shaft	X X X	
11	461056	Discharge Chute	X X	53	481024	Seal, Top	X X X	
	461057	Discharge Chute	X	54	481022	Bearing Assembly (1 required per spindle)	X X X	
12	04001-09	Bolt, Hex Head 5/16-18 x 1"	X X X	55	48667	Relief Fitting, Tapered Spindle	X X X	
13	04021-10	Nut, Hex Elastic Stop 5/16-18	X X X	56	43294	Spindle Housing	X X X	
14	04017-16	Bolt, Hex Serrated Flange 5/16-18 x 3/4"	X X X	57	481025	Seal, Bottom	X X X	
15	44078	"J" Rod	X	58	43312	Spacer, Outside	X X X	
	44101	"J" Rod	X X	59	43296	Spacer, Inside	X X X	
16	45037	Idler Pivot Base	X X X	60	04063-08	Key, 1/4 x 1/4 x 2"	X X X	
17	04001-46	Bolt, Hex Head 3/8-16 x 2-1/4"	X X X	61	04001-10	Bolt, Hex Head 5/16-18 x 1-1/4"	X X X	
18	48100-05	Bushing	X X X	62	43279	Spacer, Tapered Spindle	X X X	
19	481035	Nut, Special 1-1/16-18	X X X	63	48110	Cutter Blade, 16-1/2" Standard	X	
20	04019-03	Nut, Hex Serrated Flange 5/16-18	X X X		48184	Cutter Blade, 16-1/2" High Lift	X	
21	46081	Idler Arm (Includes bushings & grease fittings)	X X X		48108	Cutter Blade, 18" Standard	X	
22	43077	Spacer	X X X		48185	Cutter Blade, 18" High Lift	X	
23	43028	"J" Rod	X X		48111	Cutter Blade, 21" Standard	X	
	44078	"J" Rod	X		48304	Cutter Blade, 21" High Lift	X	
24	04021-09	Nut, Hex Elastic Stop 3/8-16	X X X	64	481050	Spring, Discharge Chute	X X X	
25	48114-04	Grease Fitting	X X X	65	461073	Electric Clutch	X X X	
26	04041-08	Flatwasher, 3/4"	X X X	66	04001-108	Bolt, Hex Head 5/16-18 x 4.25"	X X X	
	04041-08S	Flatwasher, 3/4" Special	X X X	67	421616	Belt Cover, LH	X	
27	04050-02	Ring, Retaining 3/4" External "E"	X X X		421615	Belt Cover, RH	X	
28	48181	Pulley, Idler	X X X		42889	Belt Cover, LH	X	
29	43297	Spindle Bushing, Bottom	X X X		42890	Belt Cover, RH	X	
30	48924	Pulley, LH Spindle	X X		421292	Belt Cover, LH	X	
	48753	Pulley, LH Spindle	X		421293	Belt Cover, RH	X	
31	48926	Tapered Hub, 1-1/8 Bore	X X X	68	48924	Pulley, RH Spindle	X X X	
32	04001-01	Bolt, Hex Head 1/4-20 x 3/4"	X X X	69	04001-109	Bolt, Hex Head 1/4-20 x 1.375 Full Thread	X X X	
33	04001-41	Bolt, Hex Head 5/8-11 x 9-1/2"	X X X	70	*	Nut, Hex 5/8-11 UNC	X X X	
34	48087	Belt, RH Blade Drive	X	71	04050-05	Ring, Retaining 1-1/8" External "E"	X X X	
	48285	Belt, RH Blade Drive	X	72	46963	Idler Arm (Includes bushings & grease fittings)	X	
	48265	Belt, RH Blade Drive	X		73	04001-51	Bolt, Hex Head 3/8-16 X 3 3/4"	X
35	04001-23	Bolt, Hex Head 3/8-16 x 4-1/2"	X X X	74	04030-04	Lockwasher 3/8	X	
36	48550	Pulley, Idler Cutter Engagement	X X X	75	43369	Nut, 3/8-16 Special W/Washer	X	
37	48923	Pulley, Double Groove	X X					
	48940	Pulley, Double Groove	X					
38	48799	Belt, Blade Drive	X					
	481001	Belt, Blade Drive	X					

CUTTER DECK CONTROLS 48", 52" & 61" DECKS

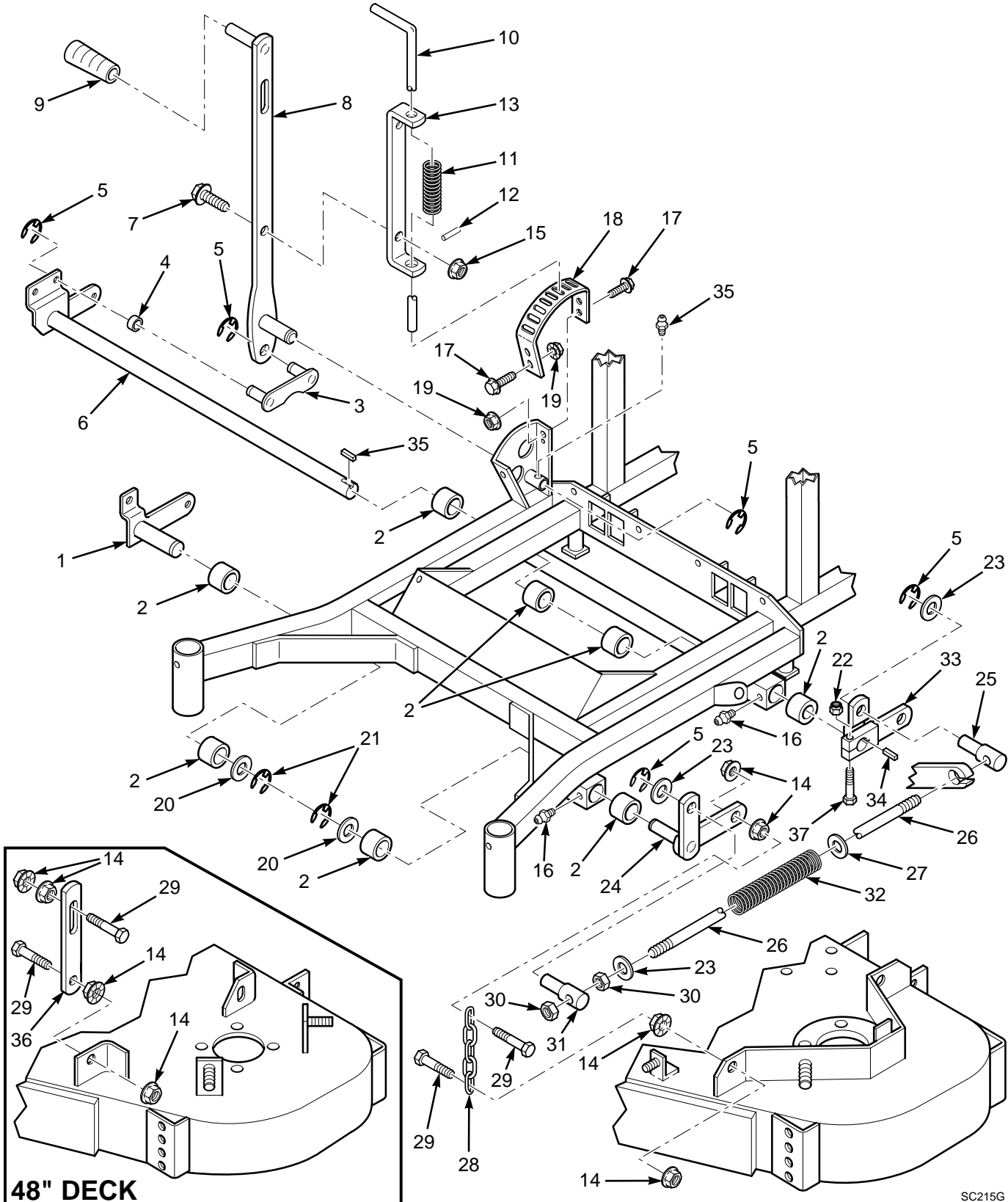

SC215G

CUTTER DECK CONTROLS 48", 52", & 61" DECKS

Ref. Part No. Number Description	48	52	61
1 45524 Bellcrank, Lift - Right Front	X	X	X
2 48100-05 Bushing	X	X	X
3 45527 Lift Link	X	X	X
4 43180 Bushing		X	X
5 04050-01 Retaining Ring, 5/8" External "E"		X	X
6 45610 Lift Arm Weldment	X		
45523 Lift Arm Weldment		X	X
7 04017-17 Bolt, Serrated Flange Hex Head 5/16-18 x 1"	X	X	X
8 46384 Height Adjustment Lever (Includes grip)	X	X	X
9 48093 Grip, Lever Lift	X	X	X
10 44065 Rod, Cutter Deck Lock	X	X	X
11 48053 Spring, Deck Lift Index	X	X	X
12 04060-01 Roll Pin, 5/32 x 3/4"		X	X
13 42887 Lock, Rod Guide	X	X	X
14 04019-04 Nut, Serrated Flange Hex 3/8-16	X	X	X
15 04019-03 Nut, Serrated Flange Hex 5/16-18		X	X
16 48114-04 Grease Fitting	X	X	X
17 04017-05 Bolt, Serrated Flange Hex Head 1/4-20 x 3/4"		X	X
18 42828 Strip, Height Adjustment	X	X	X
19 04019-02 Nut, Serrated Flange Hex 1/4-20		X	X
20 04041-08S Flatwasher, 3/4" (.766 x 1.250 x .075)		X	X
21 04050-02 Ring, Retaining 3/4" External "E"		X	X
22 04021-09 Nut, Elastic Stop 3/8-16	X	X	X
23 04040-09 Flatwasher, 5/8" (.656 x 1.312 x .075)	X	X	X
24 45313 Bellcrank, Lift - Left Front	X	X	X
25 43271 Swivel Joint - LH THD	X	X	X
26 04004-18 Adjustment Stud	X		
04004-15 Adjustment Stud		X	X
27 04040-10 Flatwasher, 5/8" (.688 x 1.75 x .134)	X	X	X
28 48540 Chain		X	X
29 04001-20 Bolt, Hex Head 3/8-16 x 1-1/2"	X	X	X
30 04020-09 Nut, Hex 5/8-11	X	X	X
31 43270 Swivel Joint - RH	X	X	X
32 481045 Spring, Deck Lift	X		
32 48953 Spring, Deck Lift		X	X
33 45427 Bellcrank	X	X	X
34 04063-15 Key, 3/16 x 3/16 x .75"	X	X	X
35 48114-05 Grease Fitting		X	X
36 421585 Link, Deck Support	X		
37 04001-45 Bolt, Hex Head 3/8-16 x 2"	X	X	X

* Common hardware which should be purchased locally. All bolts Grade 5 plated, all other fasteners zinc plated.

SHEET METAL COMPONENTS

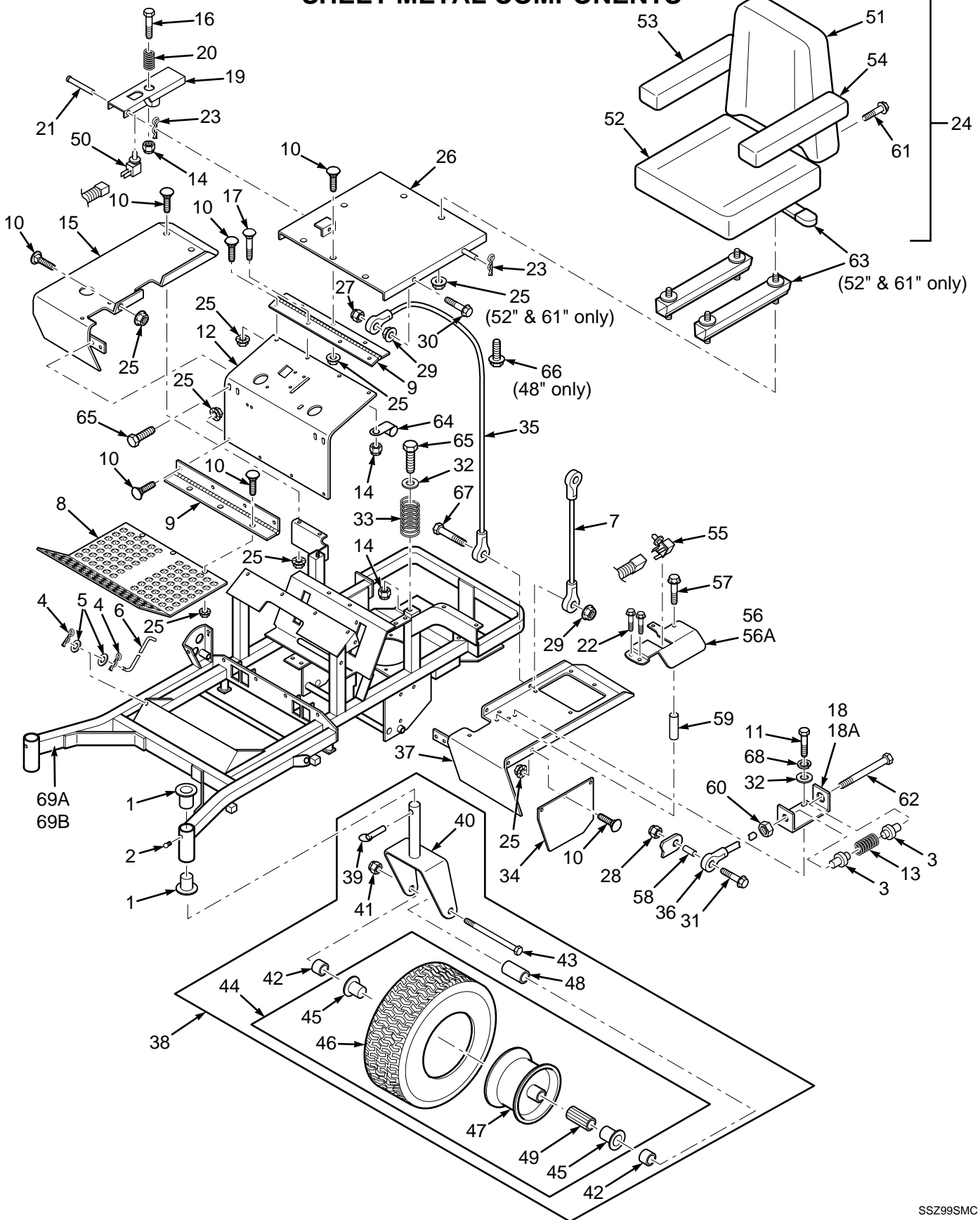

SHEET METAL COMPONENTS

Ref. Part				Ref. Part			
No.	Number	Description	48 52 61	No.	Number	Description	48 52 61
1	48100-08	Bushing	X X X	35	48566	Cable, Seat Stop	X X X
2	48114-04	Grease Fitting	X X X	36	48464	Ball Joint, Neutral	X X X
3	43257	Bushing, Spring Keeper	X X X	37	45971	Fender, LH	X X X
4	04062-02	Hair Pin, .08 Diameter x 1-3/16"	X X X	38	46392	Caster Wheel Yoke Assembly	X X X
5	04041-07	Flatwasher, 3/8" (.391 x .738 x .105)	X X X	39	04066-01	Quick Pin	X X X
6	44062	Rod, Foot Plate Latch	X X X	40	45325	Caster Wheel Yoke	X X X
7	481086	Cable, Seat Stop	X X X	41	04021-07	Nut, Elastic Stop 1/2-13	X X X
8	421589	Foot Plate	X	42	43041	Spacer	X X X
	42764	Foot Plate	X X	43	04001-80	Bolt, Hex Head 1/2-13 x 6-1/2"	X X X
9	481049	Hinge	X X X	44	48537	Wheel Assembly, Complete	X X X
10	04003-12	Bolt, Carriage 5/16-18 x 3/4"	X X X	45	48006-07	Retainer	X X X
11	04001-08	Bolt, Serrated Flange Hex Head 5/16-18 x 3/4"	X X X	46	48537-02	Tire Only	X X X
12	422528	Kick Plate	X X X	47	48537-03	Rim Only	X X X
13	48746	Neutral Return Spring	X X X	48	43022	Sleeve	X X X
14	04021-10	Nut, Elastic Stop 5/16-18	X X X	49	48006-06	Roller Bearing	X X X
15	461085	Fender Assembly, RH (with decal)	X X X	50	48717	Seat Switch	X X X
16	04001-73	Bolt, Hex Head 5/16-18 x 3-3/4"	X X X	51	481532-01	Seat, Back Cushion	X X X
17	04003-04	Bolt, Carriage 5/16-18 x 1"	X X X	52	481532-02	Seat, Bottom Cushion	X X X
18	421411	Retainer, Neutral Spring, LH	X X X	53	481532-03	Arm Pad, RH	X X X
18A	421412	Retainer, Neutral Spring, RH	X X X	54	481532-04	Arm Pad, LH	X X X
19	45405	Seat Switch Bracket	X X X	55	481474	Neutral Interlock Switch	X X X
20	48463	Spring	X X X	56	422535	Neutral Lock Bracket, RH	X X X
21	04064-04	Clevis Pin	X X X	56A	422536	Neutral Lock Bracket, LH	X X X
22	04017-15	Bolt, Serrated Flange Hex Head 5/16-18 x 1/2"	X X X	57	04017-24	Bolt, Serrated Flange Hex Head 5/16-18 x 2-3/4"	X X X
23	04062-02	Hair Pin, Cotter	X X X	58	43240	Spacer, Neutral Spring	X X X
24	481532	Seat Assembly	X	59	43258	Spacer, Neutral Lock Bracket	X X X
	481606	Seat Assembly w/Adjuster Rails	X X	60	04020-14	Nut, Hex 3/8-24 UNF	X X X
25	04019-03	Nut, Serrated Flange Hex 5/16-18	X X X	61	48704-06	Bolt, Hex Head w/Washer, 1/4-20 x 3/4"	X X X
26	46754	Seat Base	X X X	62	04001-99	Bolt, Hex Head 3/8-24 x 6-1/2", UNF	X X X
27	04021-08	Nut, Elastic Stop 1/4-20	X X X	63	46570	Seat Adjustment, Track Set	X X X
28	04021-09	Nut, Elastic Stop 3/8-16	X X X	64	48030-09	Cable Clamp, .50 ID	X X X
29	04019-02	Nut, Serrated Flange Hex 1/4-20	X X X	65	04001-09	Bolt, Hex Head 5/16-18 x 1"	X X X
30	04017-06	Bolt, Serrated Flange Hex Head 1/4-20 x 1"	X X X	66	04017-16	Bolt, Serrated Flange Hex Head 5/16-18 x 1"	X
31	04001-31	Bolt, Hex Head 3/8-16 x 2-1/2"	X X X	67	*	Bolt, Hex Head 1/4-20 x 1.25"	X X X
32	04001-15	Flatwasher, 5/16" (.313 x .875 x .083)	X X X	68	*	Lockwasher, 5/16"	X X X
33	481704	Seat Spring	X X X	69A	461083	Main Frame Assy.	X
34	421198	Fender Panel, LH	X X X	69B	461084	Main Frame Assy.	X X

* Common hardware which should be purchased locally. All bolts Grade 5 plated, all other fasteners zinc plated.

HYDRAULIC COMPONENTS

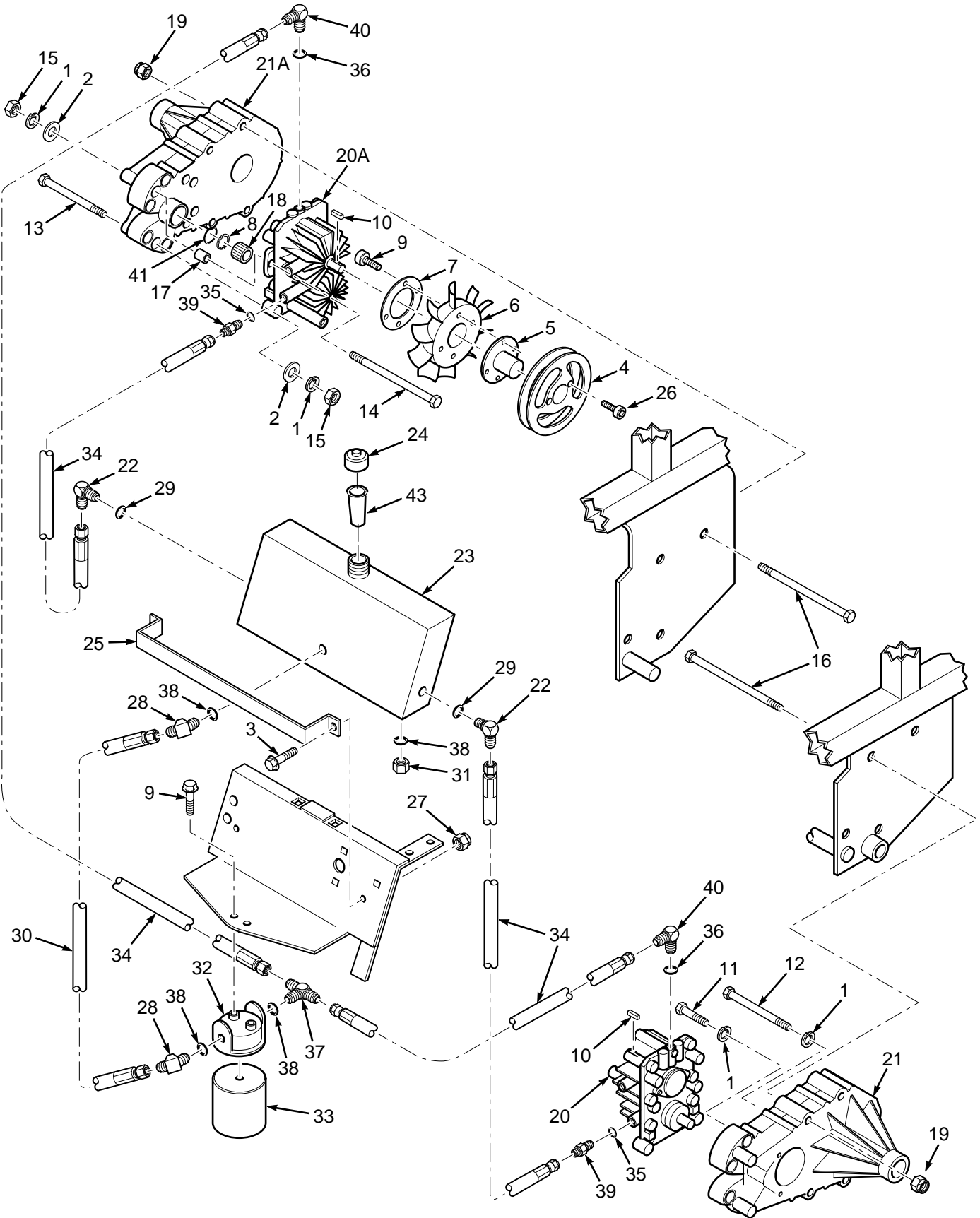

HYDRAULIC COMPONENTS

Ref. Part No. Number Description	48	52	61
1 04030-03 Lockwasher, 5/16"	X	X	X
2 04040-04 Flatwasher, 5/16" (.344 x .688 x .065)	X	X	X
3 04017-05 Bolt, Serrated Flange Hex Head 1/4x20x3/4"	X	X	X
4 48790 Pump, Pulley	X	X	X
5 48791 Tapered Hub, 15 mm Bore	X	X	X
6 481696 Fan	X	X	X
7 421209 Washer, Back-up	X	X	X
8 04050-13 Snap Ring	X	X	X
9 04010-19 Capscrew 1/4-20x1/2"	X	X	X
10 04063-14 Key, 5 mm x 5 mm x 25 mm	X	X	X
11 04001-12 Bolt, Hex Head 5/16-18 x 1-3/4"	X	X	X
12 04001-96 Bolt, Hex Head 5/16-18 x 4-1/2"	X	X	X
13 04001-95 Bolt, Hex Head 5/16-18 x 5"	X	X	X
14 04001-94 Bolt, Hex Head 5/16-18 x 7-1/2"	X	X	X
15 04020-03 Nut, Hex 5/16-18	X	X	X
16 04001-132 Bolt, Hex Head 3/8-16x4", grade 8 black	X	X	X
17 48878 Spacer	X	X	X
18 48875 Gear	X	X	X
19 04021-18 Nut, Elastic Stop 3/8-16, grade 8 black	X	X	X
20 48784 Pump, LH (Includes spacers)	X	X	X
20A 48785 Pump, RH (Includes spacers)	X	X	X
21 481578 Axle, LH (Includes brake lever)	X	X	X
21A 481577 Axle, RH (Includes brake lever)	X	X	X
22 48350-09 Elbow, 90 Degree 9/16-18 JIC to 9/16-18 "O" Ring	X	X	X
23 48860 Oil Tank Reservoir	X	X	X
24 481164 Cap, Oil Reservoir	X	X	X
25 421208 Strap, Oil Reservoir	X	X	X
26 04015-14 Screw, Socket Hex Cap 1/4-20 x 1-3/8"	X	X	X
27 04021-08 Nut, Elastic Stop 1/4-20	X	X	X
28 48485-01 Elbow, 45 Degree 3/4-16 JIC to 3/4-16 "O" Ring	X	X	X
29 48603-06 "O" Ring, 5/64 x 15/32 ID	X	X	X
30 48872 Hose Assembly, Filter Inlet	X	X	X
31 48604-02 Plug, 3/4-16 "O" Ring	X	X	X
32 48462-02 Head, Oil Filter	X	X	X
33 48462-01 Oil Filter, Special	X	X	X
34 48871 Hose Assembly	X	X	X
35 48603-04 "O" Ring, 3/32 x 3/4 ID	X	X	X
36 48603-03 "O" Ring, 1/16 x 3/8 ID	X	X	X
37 48810-01 1/2" T-fitting, 3/4-16 JIC to 3/4-16 "O" Ring	X	X	X
38 48603-02 "O" Ring, 3/32 x 5/8 ID	X	X	X
39 48572-02 Tube Union 3/4-16 JIC to 7/8-14 "O" Ring	X	X	X
40 48350-10 Elbow, 90 Degree 9/16-18 JIC to 7/16-20 "O" Ring	X	X	X
41 HG50267 "O" Ring	X	X	X
42 481090 Gasket, Hydraulic Tank Cap	X	X	X
43 481507 Filler Neck Insert	X	X	X

* Common hardware which should be purchased locally. All bolts Grade 5 plated, all other fasteners zinc plated.

BDU-10L HYDRAULIC PUMP

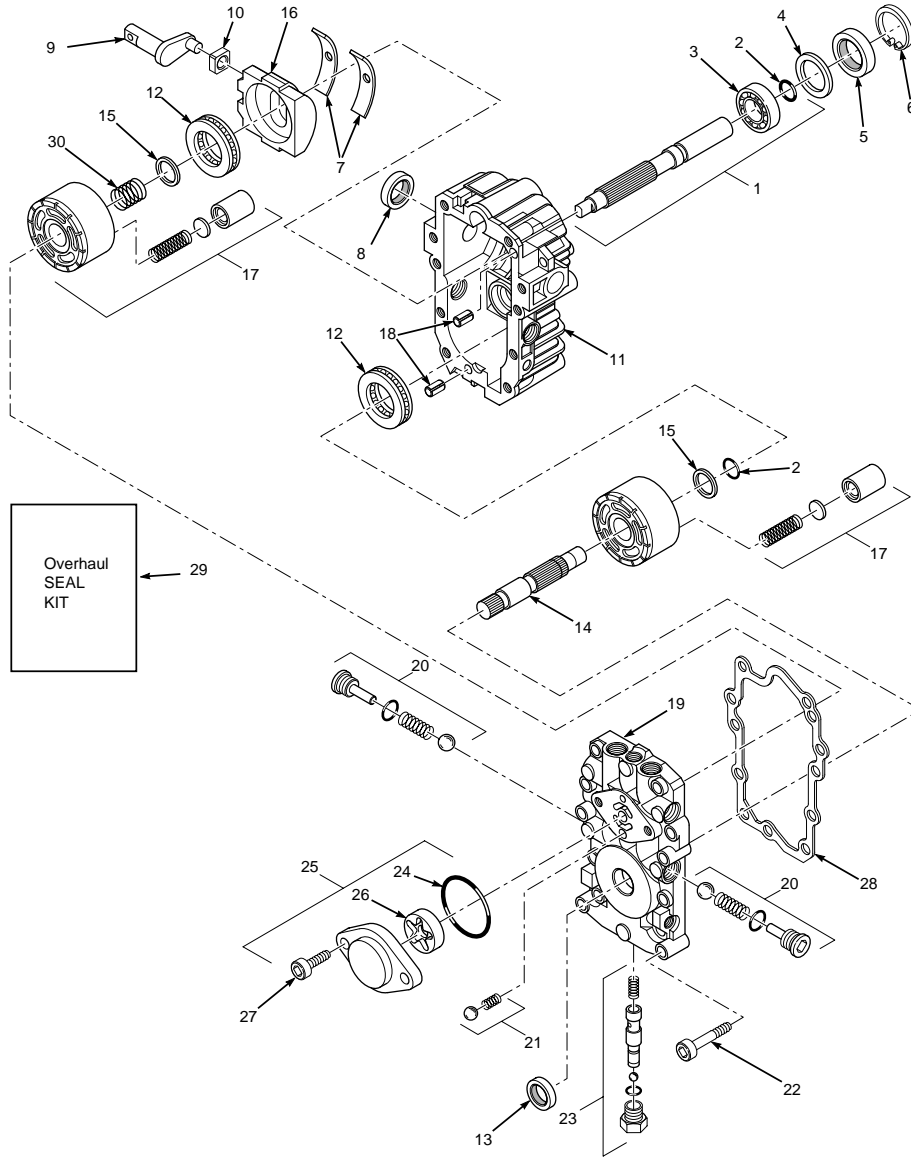

SC226G

Ref. Part No.	Part Number	Description	Ref. Part No.	Part Number	Description
1	HG2513038	Pump Shaft Kit	16	HG2003087	Variable Swash Plate
2	HG2003016	Wire Retaining Ring	17	HG70079	BDP-10L Block Assembly
3	HG2003043	Ball Bearing	18	HG9004800-2506	Pin ST Holder
4	HG2003018	Spacer	19	HG2513006	Center Section Kit
5	HG9008000-0128	Lip Seal (16 x 35 x 7)	20	HG2510027	Check Valve Kit
6	HG2003052	Retaining Ring	21	HG2510011	Charge Relief Kit
7	HG2003023	Cradle Bearing	22	HG9007314-0808	Socket Head Cap Screw
8	HG9008000-126	Lip Seal (12 x 35 x 7)	23	HG2513011	Bypass Valve Kit
9	HG2003005	Trunnion Arm	24	HG9004101-1340	O-Ring
10	HG2000015	Slot Guide	25	HG2513027	Charge Pump Cover
11	HG2513020	Transmission Housing Kit RH	26	HG50273	Gerotor Assembly
	HG2513003	Transmission Housing Kit LH	27	HG50095	Capscrew (6mm x 20")
12	HG2003044	Thrust Ball Bearing Assembly	28	HG2003060	Center Section Gasket
13	HG9008000-0127	Lip Seal (15 x 24 x 7)	29	HG2513013	Overhaul Seal Kit
14	HG2003032	Motor Shaft	30	HG2000025	Spring Block
15	HG2003017	Block Thrust Washer			

AXLE ASSEMBLY

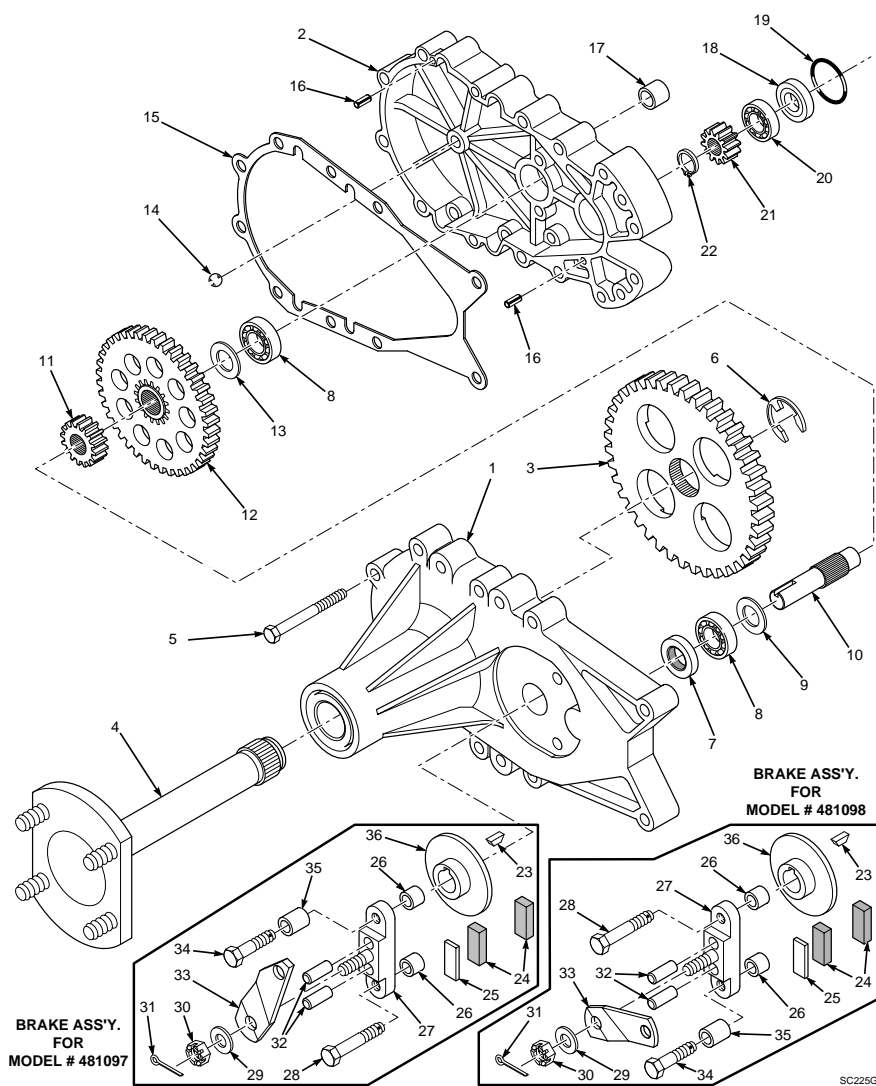

Ref. Part No. Number	Description	Ref. Part No. Number	Description
1	HG62768 Axle Housing Assembly	20	HG44232 Ball Bearing, 15mm x 35mm x 11mm
2	HG44533 Hydro Mount Housing	21	HG44353 Input Gear, 11 Tooth
3	HG44358 Splined 72 Tooth Final Drive Gear	22	HG44354 Retaining Ring
4	HG62681 Axle Shaft Assembly	23	HG44143 Key, Hi Pro 3/16 x 5/8
5	HG44366 Bolt, 1/4-20 x 2-1/2" Hex Head	24	HG44132 Puck, Brake
6	HG44359 E-Ring .875	25	HG44134 Plate, Puck
7	HG50263 Oil Seal, 1.25 x .625	26	HG23770 Brake Spacer
8	HG44147 Ball Bearing, .62 ID x 1.38 x .44	27	HG62589 Brake Yoke Assembly
9	HG44371 Washer, HT .62 ID x 1.0 OD x .05 Thick	28	HG44276 Bolt, 1/4-20 x 1-1/2" W/Patch
10	HG44351 Brake Shaft (Splined)	29	HG44130 Washer, 7/16 x 7/8 OD x .06 HT
11	HG50419 Splined Reduction Gear, 17 Tooth	30	HG44142 Nut, Castle 5/16-24 PL
12	HG50420 Splined 60 Tooth Gear	31	HG44101 Pin, Cotter
13	HG44371 Washer, HT .62 ID x 1.0 OD x .05 Thick	32	HG44127 Pin, Brake Actuating
14	HG9001214-3700 Ball, 3/8" Diameter	33	HG44094 Arm, Brake Actuator (LH Assy.)
15	HG50223 Gasket, Housing	33	HG44613 Arm, Brake Actuator (RH Assy.)
16	HG44269 Pin, Spring 3/16" x 1/2" x 12" Long	34	HG44612 Bolt, 1/4-20 x 2-1/2"
17	HG23747 Mounting Spacer	35	HG23711 Spacer, Torsion Spring
18	HG44355 Bearing, Spacer	36	HG44090 Disc, Brake
19	HG50267 O-Ring		

TRACTION DRIVE COMPONENTS

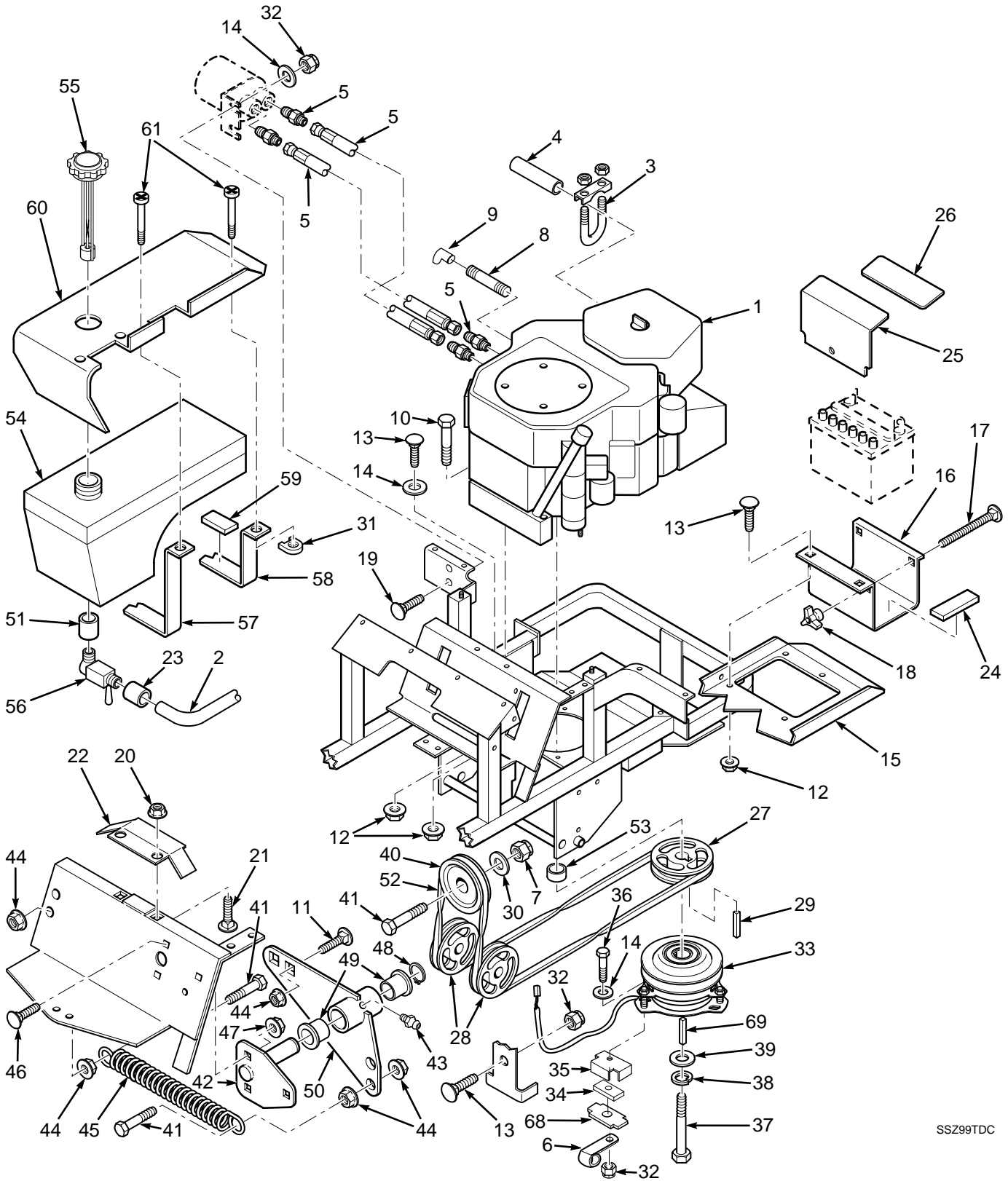

SSZ99TDC

TRACTION DRIVE COMPONENTS

Ref. Part				Ref. Part			
No.	Number	Description	48 52 61	No.	Number	Description	48 52 61
1	481116	Engine 18 hp Kohler CV For SSZ-18CV	X	35	422533	Backing Plate	X X X
	481117	Engine 20 hp Kohler CV For SSZ-20CV	X X X	36	04001-12	Bolt, Hex Head 5/16-18 x 1-3/4"	X X X
	481118	Engine 22 hp Kohler CV For SSZ-22CV	X X X	37	04001-93	Bolt, Hex Head 7/16-20 x 3.00"	X X X
2	48058-03	Fuel Hose	X X X	38	04030-05	Lockwasher, 7/16"	X X X
3	48633	Muffler Clamp	X X X	39	04041-28	Flatwasher, Retainer	X X X
4	48964	Tube, Exhaust	X X X	40	48181	Idler, Pulley	X X X
5	*	Kohler Fittings, Purchase From Kohler	X X X	41	04001-21	Bolt, Hex Head 3/8-16 x 1.75"	X X X
6	48030-09	Clamp, 50 ID	X X X	42	45650	Pivot Weldment, Idler Arm	X X X
7	04021-09	Nut, 3/8-16 Elastic Stop	X X X	43	48114-04	Grease Fitting	X X X
8	48402-06	Extention, 2.50"	X X X	44	04019-04	Nut, Serrated Flange Hex 3/8-16	X X X
9	48600-01	Elbow, Street	X X X	45	48961	Spring, Pump Drive Idler	X X X
10	04017-19	Bolt, 5/16-18 x 1-1/2" Serr. Flng. Hex Head	X X X	46	04003-12	Bolt, Carriage 5/16-18 x 3/4	X X X
11	04003-05	Bolt, 7/8-16 x 1.50" Carriage	X X X	47	04019-03	Nut, Serrated Flange Hex 5/16-18	X X X
12	04019-03	Nut, Serrated Flange Hex Head 5/16-18	X X X	48	04050-05	Ring, Retaining 1.125 Diameter External "E"	X X X
13	04003-12	Bolt, Carriage 5/16-18 x 3/4"	X X X	49	48100-02	Bushing, 1.125 Sintered	X X X
14	04040-15	Flatwasher, 5/16" (.313 x .875 x .083)	X X X	50	46755	Idler Arm Weldment, Pump Drive	X X X
15	45479	Fender, LH	X X X	51	48309	Bushing, Fuel Tank Valve	X X X
16	421197	Battery Box	X X X	52	48760	Belt, Pump Drive	X X X
17	04003-01	Bolt, Carriage 1/4-20 x 6"	X X X	53	43248	Spacer, Crankshaft	X X X
18	04029-01	Wing Nut, 1/4-20	X X X	54	48651	Fuel Tank (Includes shut-off valve)	X X X
19	04003-04	Bolt, Carriage 5/16-18 x 1"	X X X	55	481556	Fuel Tank Cap	X X X
20	04019-02	Nut, Serrated Flange Hex 1/4-20	X X X	56	48308	Fuel Shut-off Valve	X X X
21	04003-02	Bolt, Carriage 1/4-20 x 3/4"	X X X	57	42944	Fuel Tank Strap, Long	X X X
22	421624	Belt Guard	X X X	58	42945	Fuel Tank Strap, Short	X X X
23	48059-01	Fuel Hose Clamp	X X X	59	48657	Rubber Pad	X X X
24	48661	Rubber Pad	X X X	60	461085	Fender Assembly, RH (with decal)	X X X
25	42392	Battery Cover	X X X	61	04010-10	Screw, Machine 1/4-20 x 2" Phillips Head	X X X
26	48099	Pad, Battery Cover	X X X	62	04017-19	Bolt, 5/16-18 x 1-1/2" Serr. Flng. Hex Head	X X X
27	48792	Pulley	X X X	63	04003-05	Bolt, Carriage 7/8-16 x 1.50"	X X X
28	48790	Pulley, Pump	X X X	64	04021-09	Nut, Elastic Stop 3/8-16	X X X
29	04063-06	Key, 1/4 x 1/4 x 1-1/2"	X	65	48030-09	Clamp, .50 ID	X X X
30	04041-07	Flatwasher, 3/8" (.391 x .938 x .105)	X X X	66	*	Kohler Fittings, Purchase From Kohler	X X X
31	04110-01	U-Nut, 1/4-20	X X X	68	422534	Backing Plate	X X X
32	04021-10	Nut, Elastic Stop 5/16-18	X X X	69	04063-24	Key, 1/4 x 1/4 x 2.75	X X X
33	461073	Electric Clutch	X X X				
34	481716	Rubber Pad, Clutch Stop	X X X				

* Kohler hardware which should be purchased from an authorised Kohler Dealer.

BRAKE AND STEERING CONTROLS

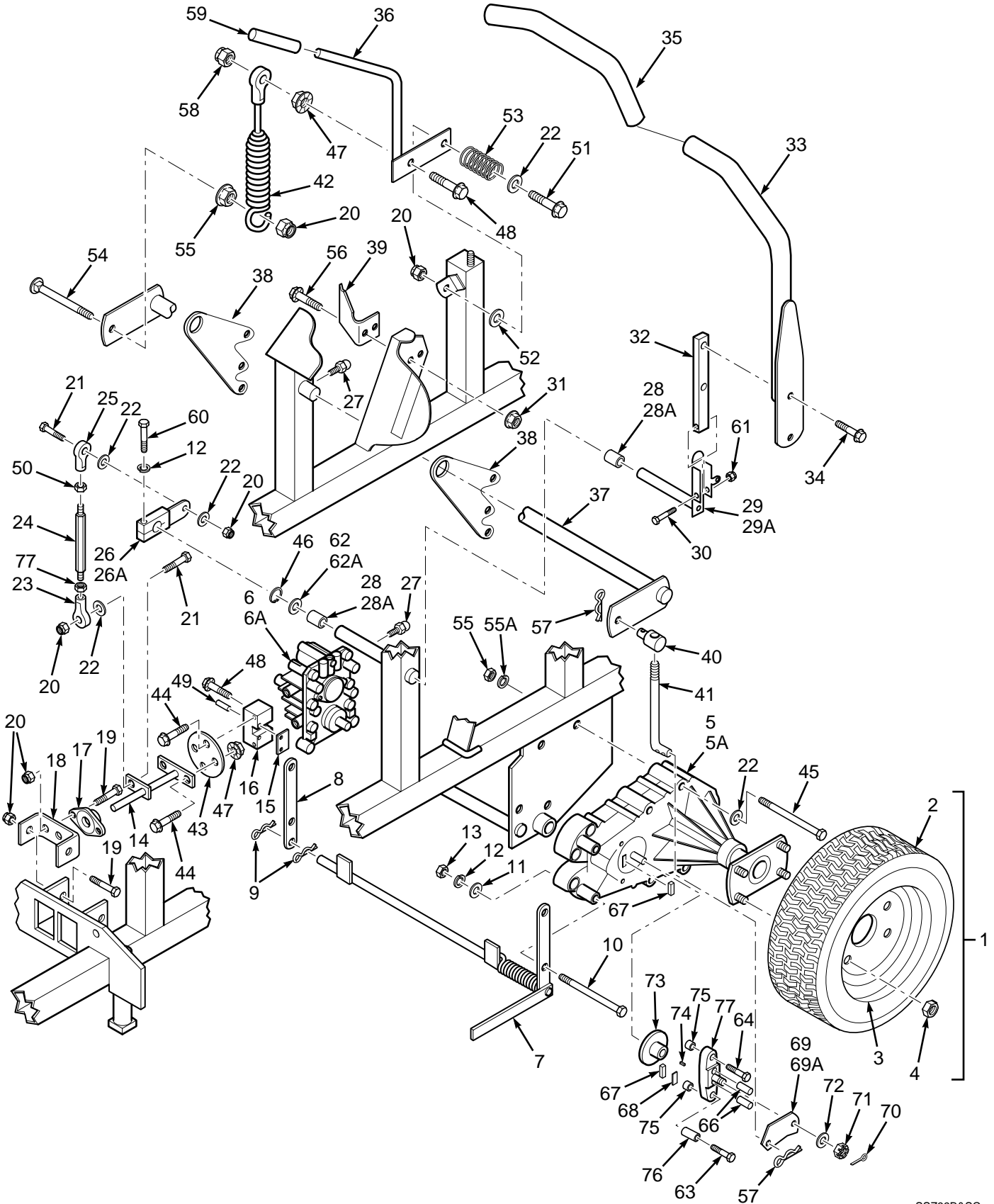

BRAKE AND STEERING CONTROLS

Ref. Part				Ref. Part			
No.	Number	Description	48 52 61	No.	Number	Description	48 52 61
1	481503	Drive Wheel Assembly	X	39	421266	Latch, Brake	X X X
1	481504	Drive Wheel Assembly	X X X	40	43256	Swivel Joint	X X X
2	481619	Tire Only	X X X	41	44080	Rod, Brake	X X X
3	48321-04	Rim Only	X	42	48840	Cable Assembly, Parking Brake	X X X
3	48958-03	Rim Only	X X X	43	422273	Plate, Coupler	X X X
4	04028-01	Lug Nut, 1/2-20	X X X	44	04017-05	Bolt, Serrated Flange Hex Hd 1/4-20 x 3/4"	X X X
5	481578	Axle, LH (Includes brake lever)	X X X	45	04001-132	Bolt, Hex Head 3/8-16 x 4", grade 8	X X X
5A	481577	Axle, RH (Includes brake lever)	X X X	46	04050-02	Ring, Retaining 3/4" External "E"	X X X
6	48784	Pump, LH	X X X	47	04019-02	Nut, Serrated Flange Hex 1/4-20	X X X
6A	48785	Pump, RH	X X X	48	*	Bolt, Serr.Flng.Hex Head 1/4-20 x 1-1/4"	X X X
7	45464	Dump Valve, Lever Weldment	X X X	49	04060-06	Roll Pin, 3/16 x 3/4"	X X X
8	421212	Bracket, Mounting	X X X	50	*	Nut, Hex 3/8-24	X X X
9	04062-01	Hair Pin	X X X	51	*	Bolt, Hex Head 3/8-16 x 2"	X X X
10	04001-95	Bolt, Hex Head 5/16-18 x 5"	X X X	52	04041-12	Flatwasher, 3/8 (.375 x 1-1/2" x 16 ga.)	X X X
11	*	Flatwasher, 5/16"	X X X	53	48050	Spring, Brake Lever	X X X
12	*	Lockwasher, 5/16"	X X X	54	*	Bolt, Carriage 3/8-16 x 1-1/2"	X X X
13	*	Nut, Hex 5/16-18	X X X	55	04021-18	Nut, Elastic Stop 3/8-16 grade 8, black	X X X
14	45462	Pump Weldment Shaft	X X X	55A	04030-09	Lockwasher, 3/8" spring grade 8	X X X
15	421203	Clamp Plate	X X X	56	04017-16	Bolt, Serr. Flng. HexHead 5/16-18 x 3/4"	X X X
16	48829	Block, Pump Control	X X X	57	04062-02	Hair Pin, 1/16"	X X X
17	48796	Bushing, Self Align	X X X	58	*	Nut, Elastic Stop 1/4-20	X X X
18	421204	Bracket, Bearing	X X X	59	48342	Grip, Parking Brake	X X X
19	*	Bolt, Hex Head 3/8-16 x 1"	X X X	60	*	Bolt, Hex Head 5/16-18 x 1-1/2"	X X X
20	*	Nut, Elastic Stop 3/8-16	X X X	61	04021-10	Nut, Elastic Stop 5/16-18	X X X
21	*	Bolt, Hex Head 3/8-16 x 1-1/2"	X X X	62	04041-08	Flatwasher, 3/4"	X X X
22	04041-07	Flatwasher, 3/8" Grade 8	X X X	62A	04041-08S	Flatwasher, 3/4" Special	X X X
23	48544	Ball Joint, LH Thread	X X X	63	HG44612	Bolt, 1/4-20 x 2-1/2 GR. 5 w/patch	X X X
24	43246	Link, Turnbuckle	X X X	64	HG44276	Bolt, 1/4-20 x 1-1/2 GR. 5 w/patch	X X X
25	48464	Ball Joint, RH Thread	X X X	65	04008-02	Bolt, Wheel Mounting	X X X
26	45895	Lever, Pump Transfer LH	X X X	66	HG44127	Pins, Actuating	X X X
26A	45896	Lever, Pump Transfer RH	X X X	67	HG44132	Brake Puck	X X X
27	48114-04	Grease Fitting	X X X	68	HG44134	Backing Plate	X X X
28	48100-06	Bushing, LH	X X X	69	HG44094	Actuating Lever, RH	X X X
28A	48100-05	Bushing, RH	X X X	69A	HG44613	Actuating Lever, LH	X X X
29	45897	Control Lever, LH	X X X	70	*	Pin, Cotter	X X X
29A	45898	Control Lever, RH	X X X	71	HG44142	Nut, Castle	X X X
30	*	Bolt, Hex Head 5/16-18 x 1-1/2"	X X X	72	HG44130	Washer, 7/16 x 7/8 OD x .06 HT	X X X
31	04019-03	Nut, Serrated Flange Hex 5/16-18	X X X	73	HG44090	Disc, Brake	X X X
32	421145	Bar Control Lever	X X X	74	HG44143	Key, Hi Pro 3/16 x 5/8	X X X
33	461037	Control Handle (with item # 35)	X X X	75	HG23770	Brake Spacer	X X X
34	04017-27	Bolt, Serrated Flange Hex Head 3/8-16 x 1"	X X X	76	HG23711	Spacer, Torsion Spring	X X X
35	481599	Grip, Control Handle	X X X	77	HG62589	Brake Yoke Assembly	X X X
36	45482	Lever Weldment, Parking Brake	X X X	78	04008-02	Wheel Stud	X X X
37	45551	Cam Weldment, Parking Brake	X X X				
38	422459	Plate, Parking Brake	X X X				

INSTRUMENT PANEL AND ELECTRICAL COMPONENTS

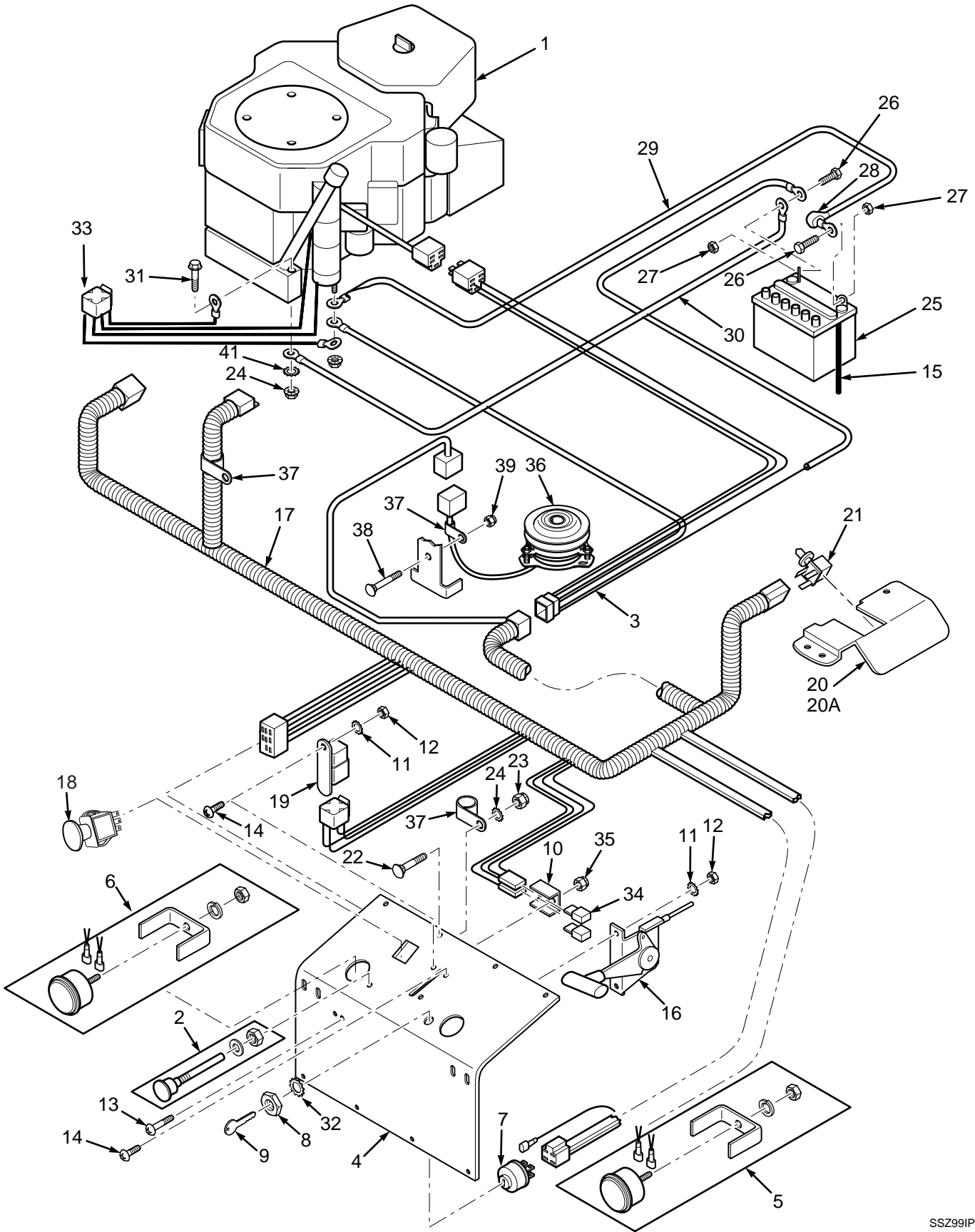

INSTRUMENT PANEL AND ELECTRICAL COMPONENTS

Ref. Part No. Number Description	48	52	61
1 481116 Engine 18 hp Kohler CV (**)	X		
481118 Engine 22 hp Kohler CV (**)		X	X
2 481278 Choke Control	X	X	X
3 481070 Adapter	X	X	X

Ref. Part No. Number Description	48	52	61
4 422528 Kick Plate	X	X	X
5 48023 Hour Meter	X	X	X
6 481755 Ammeter			
7 48798 Key Switch (Includes mounting hardware)	X	X	X
8 48017-04 Nut, Hex 5/8-32	X	X	X
9 48017-02 Key & Ring Assembly	X	X	X
10 42413 Bracket, Fuse Holder	X	X	X
11 04031-01 Lockwasher, #10 External Tooth	X	X	X
12 04020-07 Nut, Hex #10-32	X	X	X
13 04010-11 Screw, Phillips Washer Head #10-32 x 1-1/2"	X	X	X
14 04010-01 Screw, Phillips Washer Head #10-32 x 1/2"	X	X	X
15 48015-01 Overflow Tube	X	X	X
16 48879 Throttle Control	X	X	X
17 481682 Wire Harness	X	X	X
18 481687 Switch, Mower Engagement Electric Clutch	X	X	X
19 48788 Relay	X	X	X
20 421253 Neutral Lock Bracket, RH	X	X	X
20A 421252 Neutral Lock Bracket, LH	X	X	X
21 48522 Switch Neutral Lock	X	X	X
22 04003-12 Bolt, Carriage 5/16-18 x .75"	X	X	X
23 04021-10 Nut, Elastic Stop 5/16-18	X	X	X
24 04019-03 Washer, Star 5/16-18	X	X	X
25 48015 Battery	X	X	X
26 04001-44 Bolt, Hex Head 1/4-20 x 1/2"	X	X	X
27 04020-02 Nut, Hex 1/4-20	X	X	X
28 48126 Rubber Boot	X	X	X
29 48029-13 Battery Cable, 25" Red	X	X	X
30 48029-11 Battery Cable, 27" Black	X	X	X
31 04017-19 Bolt, Serrated Flange Hex Head 5/16-18 x 1.50"	X	X	X
32 48017-03 Washer, Star 5/8"	X	X	X
33 481275 Wire Harness W/Relay	X	X	X
34 48298 Fuse, Blade Type 20 amp	X	X	X
35 04021-01 Nut, Elastic Stop #10-32	X	X	X
36 461073 Electric Clutch	X	X	X
37 48030-09 Clamp	X	X	X
38 04003-12 Bolt, Carriage 5/16-18 x 3/4"	X	X	X
39 04021-10 Nut, Elastic Stop 5/16-18	X	X	X
40 04031-09 Lockwasher, 5/16" Internal Tooth	X	X	X

* Common hardware which should be purchased locally. All bolts Grade 5 plated, all other fasteners zinc plated.

** Contact engine manufacturer for replacement engine.

WIRE HARNESS ADAPTER. KOHLER V - TWIN PART NO. 481070

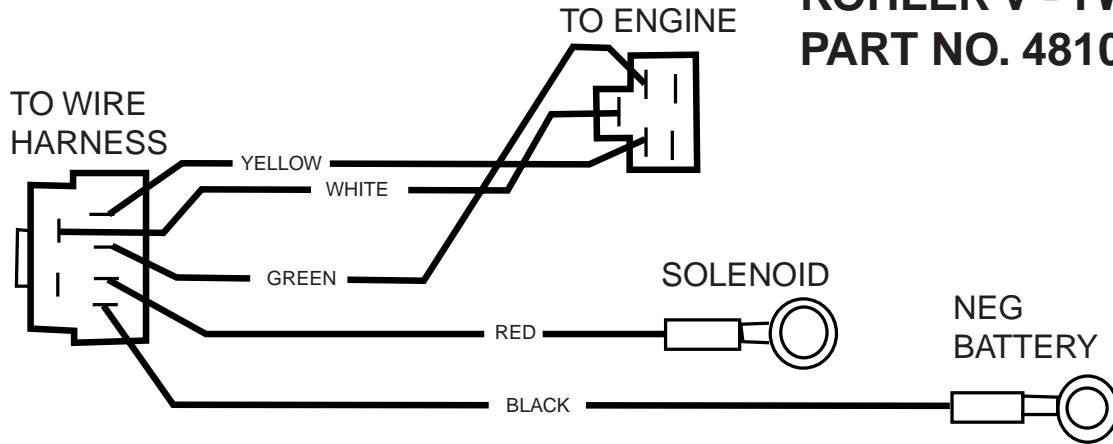

WIRE HARNESS WITH RELAY PART NO. 481275

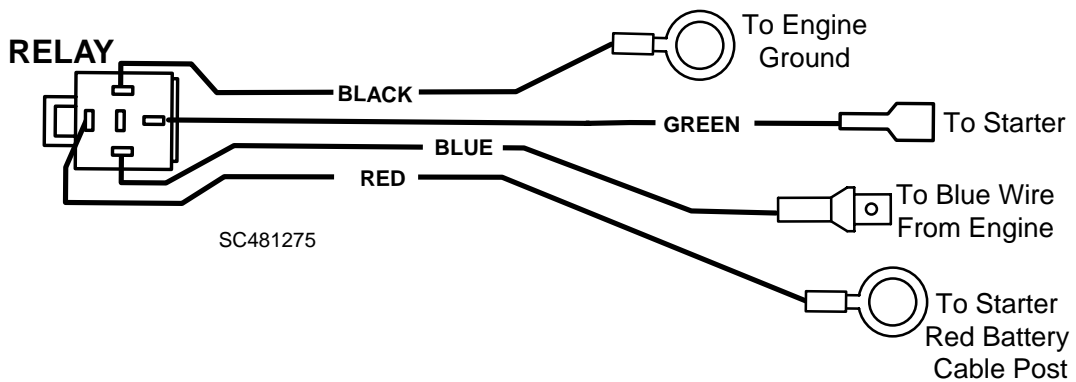

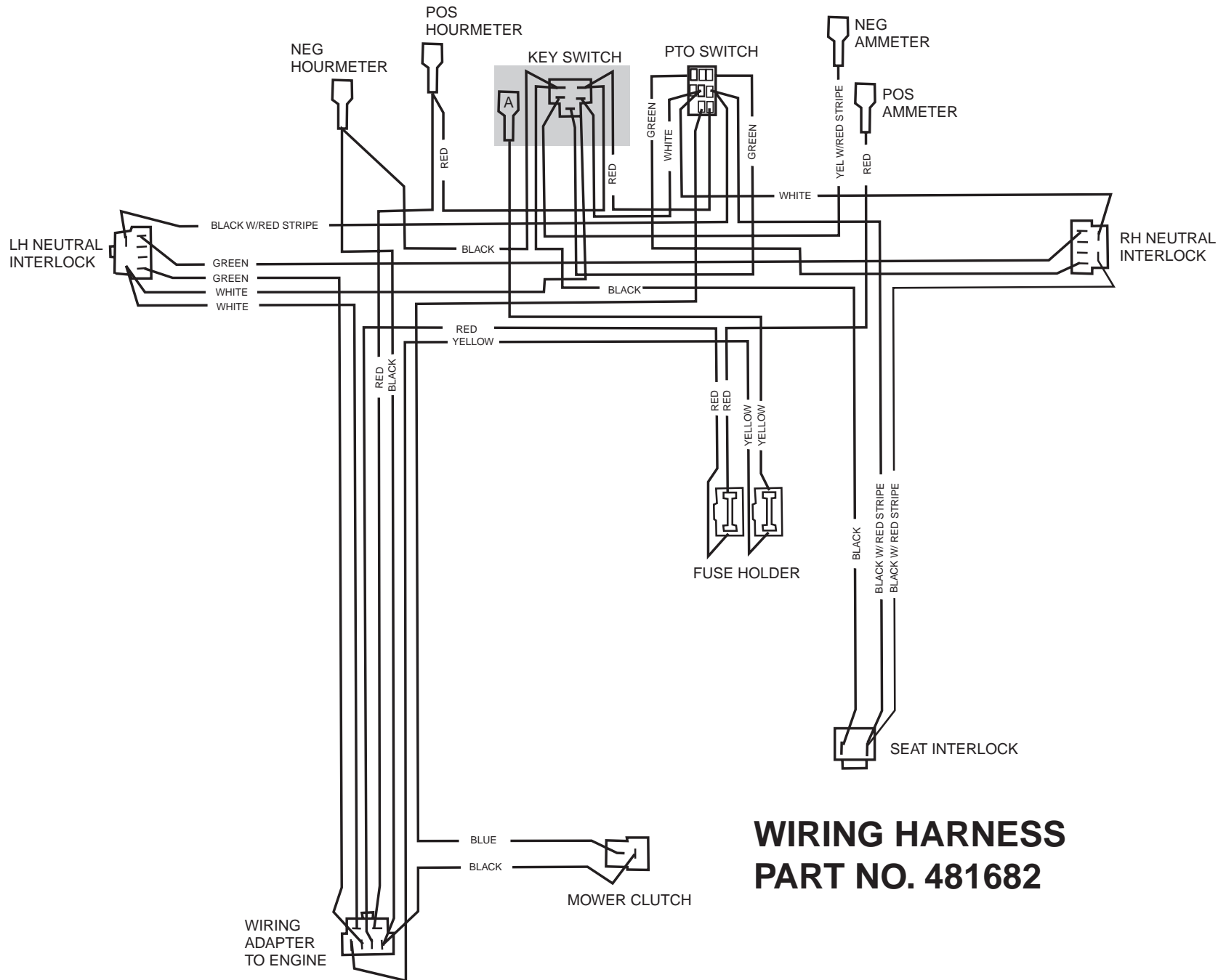

WIRING HARNESS PART NO. 481682

REPLACEMENT DECALS



48556 - Size 12" x 3.25"



48859 - Size 11.5" x 5.5"



48623 - Size 12" x 3.25"



48072



48404

48318-48"
48319-52"
48320-61"

IMPORTANT ADJUSTMENT PROCEDURES

READ OPERATOR'S MANUAL FOR MORE DETAILS



FREE WHEEL OPERATION

To move machine without running the engine, locate dump valve lever under fender in front of left drive wheel. Unhook and push forward to free wheel. Pull lever back and rehook for normal operation.

WARNING

INSTALL BELT COVER BEFORE OPERATING MACHINE

READ OPERATOR'S MANUAL

STRAIGHT-LINE RUNNING OR TRACKING ADJUSTMENT

Before making adjustment, be sure both drive tires are inflated equally. Loosen nut (D) on LH pump linkage. If machine pulls to right, move forward in slot to slow left wheel. If machine pulls to left, move rearward in slot to speed up left wheel. Readjust neutral if necessary.

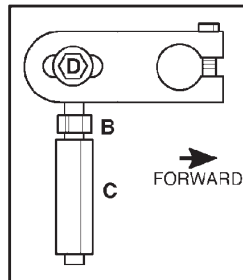

NEUTRAL ADJUSTMENT

Adjust neutral only with drive wheels elevated and machine blocked securely. Loosen jam nut (B) on the turnbuckle. If wheel rotates forward, adjust turnbuckle (C) clockwise. If wheel rotates rearward, adjust turnbuckle counterclockwise. Adjust until drive wheel stops turning. Tighten jam nut.

HYDRAULIC FLUID LEVEL

Check hydraulic fluid level daily while fluid is cool. Fluid level should be 2" below top of tank. Fill with SAE 20W50 motor oil only.

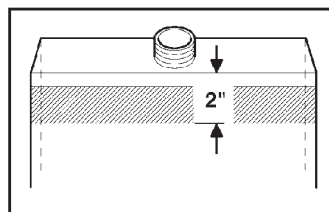

IMPORTANT!:

Do not overfill. Room for hot fluid expansion must be allowed or resulting expansion may cause leaks in the system.

481041

REPLACEMENT DECALS

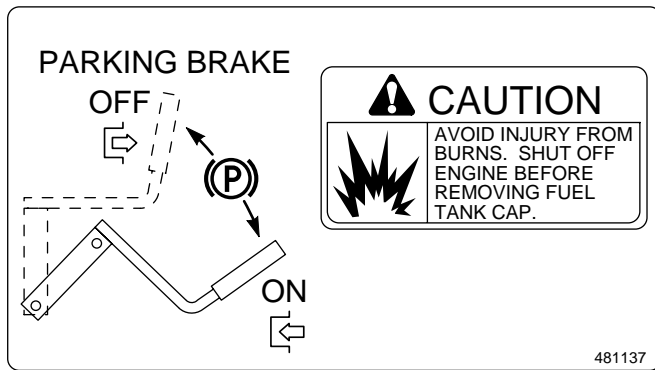

481137



481039



481040

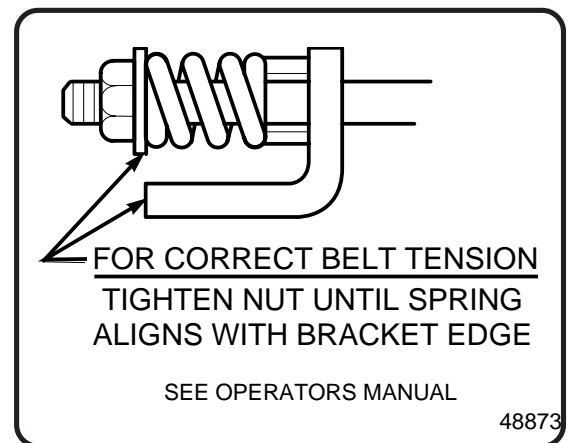

48873

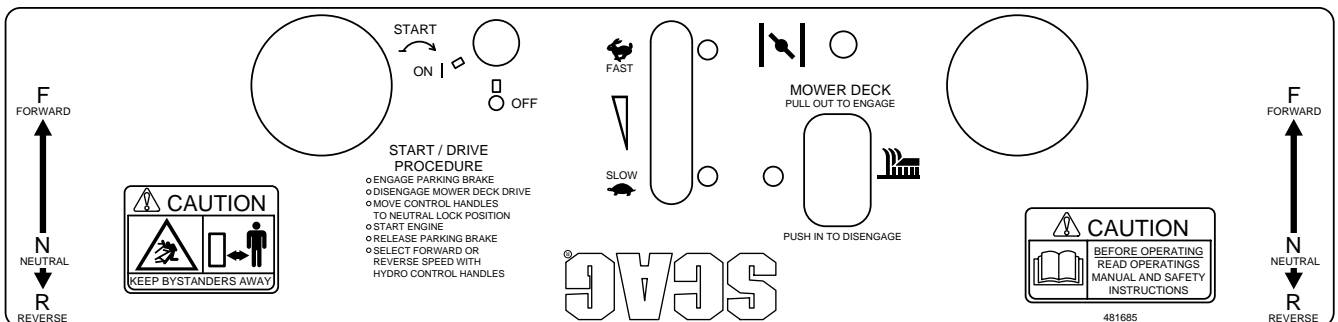

481685

REPLACEMENT DECALS



481099



481042



48071



48825 - Size 8.5" x 2"

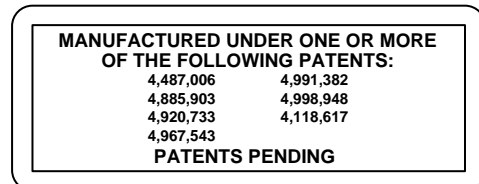

48656

48656

LIMITED WARRANTY-COMMERCIAL EQUIPMENT

Any part of the Scag commercial mower manufactured by Scag Power Equipment and found, in the reasonable judgment of Scag, to be defective in materials or workmanship, will be repaired or replaced by an Authorized Scag Service Dealer without charge for parts and labor. This warranty is limited to the original purchaser and is not transferable. Proof of purchase will be required by the dealer to substantiate any warranty claims. All warranty work must be performed by an Authorized Scag Service Dealer.

This warranty is limited to the following specified periods from the date of the original retail purchase for defects in materials or workmanship:

- * Wear items including drive belts, blades, hoses and tires are warranted for 90 days.
- * Batteries are covered for 90 days.
- * Frame, deck, and structural components including oil reservoir, fittings, and oil cooler are warranted for 1 year.
- * Engines and electric starters are covered by the manufacturer's warranty period.
- * Drive system components are warranted for 1 year by the component manufacturer, in conjunction with Scag Power Equipment. (Excluding fittings, hoses, cooling system, oil reservoir, drive belts).
- * Electric clutch components are warranted for 1 year.
- * Cutter Spindle Assemblies 46631 have a Limited Warranty for three years (Parts and labor 1st year; Parts only 2nd and 3rd year).

Any Scag product used for rental purposes is covered by a 90 day warranty.

The Scag mower, including any defective part must be returned to an Authorized Scag Service Dealer within the warranty period. The expense of delivering the mower to the dealer for warranty work and the expense of returning it to the owner after repair will be paid for by the owner. Scag's responsibility is limited to making the required repairs and no claim of breach of warranty shall be cause for cancellation or rescission of the contract of sale of any Scag mower.

This warranty does not cover any mower that has been subject to misuse, neglect, negligence, or accident, or that has been operated in any way contrary to the operating instructions as specified in the Operator's Manual. The warranty does not apply to any damage to the mower that is the result of improper maintenance, or to any mower or parts that have not been assembled or installed as specified in the Operator's Manual and Assembly Manual. The warranty does not cover any mower that has been altered or modified, changing performance or durability. In addition, the warranty does not extend to repairs made necessary by normal wear, or by the use of parts or accessories which, in the reasonable judgment of Scag, are either incompatible with the Scag mower or adversely affect its operation, performance or durability.

Scag Power Equipment reserves the right to change or improve the design of any mower without assuming any obligation to modify any mower previously manufactured.

All other implied warranties are limited in duration to the one (1) year warranty period or ninety (90) days for mowers used for rental purpose. Accordingly, any such implied warranties including merchantability, fitness for a particular purpose, or otherwise, are disclaimed in their entirety after the expiration of the appropriate one year or ninety day warranty period. Scag's obligation under this warranty is strictly and exclusively limited to the repair or replacement of defective parts and Scag does not assume or authorize anyone to assume for them any other obligation. Some states do not allow limitations on how long an implied warranty lasts, so the above limitation may not apply to you.

Scag assumes no responsibility for incidental, consequential or other damages including, but not limited to, expense for gasoline, expense of delivering the mower to an Authorized Scag Service Dealer and expense of returning it to the owner, mechanic's travel time, telephone or telegram charges, rental of a like product during the time warranty repairs are being performed, travel, loss or damage to personal property, loss of revenue, loss of use of the mower, loss of time or inconvenience. Some states do not allow the exclusion or limitation of incidental or consequential damages, so the above limitation or exclusion may not apply to you.

This warranty gives you specific legal rights, and you may also have other rights which vary from state to state.

© 1998
SCAG POWER EQUIPMENT
DIVISION OF METALCRAFT OF MAYVILLE, INC.

PART NO. 03057
PRINTED 6/98
PRINTED IN USA