

**HOME OWNER / INSTALLER
FOR YOUR SAFETY
THIS MANUAL MUST BE READ IN ITS
ENTIRETY BEFORE OPERATING HEATER**



**RHFE-556FA III / FTRA III
ENERGYSAVER
GAS DIRECT VENT WALL FURNACE**



Owner's Operation and Installation Manual

WARNING: If the information in these instructions are not followed exactly, a fire or explosion may result causing property damage, personal injury or loss of life.

- Do not store or use gasoline or other flammable vapors and liquids in the vicinity of this or any other appliance.
- **WHAT TO DO IF YOU SMELL GAS**
 - Do not try to light any appliance.
 - Do not touch any electrical switch; do not use any phone in your building.
 - Immediately call your gas supplier from a neighbor's phone. Follow the gas supplier's instructions.
 - If you cannot reach your gas supplier, call the fire department.
- Installation and service must be performed by a qualified installer, service agency or the gas supplier.

This appliance may be installed in an aftermarket, permanently located, manufactured home (USA) or mobile home, where not prohibited by local codes.

This appliance is only for use with the type of gas indicated on the rating plate. This appliance is not convertible for use with other gases, unless a certified kit is used.

INSTALLER: Leave this manual with the appliance.
CONSUMER: Retain this manual for future reference.

Register your product at www.rinnairregistration.com or call 1-866-RINNAI1 (746-6241)

Rinnai[®]

WARNING

IMPROPER INSTALLATION, ADJUSTMENT, ALTERATION, SERVICE OR MAINTENANCE CAN CAUSE PROPERTY DAMAGE, PERSONAL INJURY OR LOSS OF LIFE. REFER TO THE OWNER'S INFORMATION MANUAL PROVIDED WITH THIS APPLIANCE. INSTALLATION AND SERVICE MUST BE PERFORMED BY A QUALIFIED INSTALLER, SERVICE AGENCY OR THE GAS SUPPLIER.

ENERGYSAVER RHFE-556FA III/FTRA III

Table of Contents

| | Page |
|---|------|
| FEATURES OF THE RHFE-556 UNITS/SAFETY DEVICES | 1 |
| TECHNICAL DATA/GAS PRESSURE SETTING | 2 |
| IMPORTANT POINTS/USAGE AND INSTALLATION MUST | 3 |
| DIMENSIONS | 5 |
| SPECIFICATIONS | 6 |
| SAFETY POINTS | 8 |
| GETTING TO KNOW YOUR NEW RHFE-556FA III/FTRA III | 10 |
| CONTROL PANEL LAYOUT..... | 11 |
| REMOTE CONTROL..... | 12 |
| CUT-AWAY DIAGRAM..... | 13 |
| NOTICE BEFORE INSTALLATION | 14 |
| INSTALLATION INSTRUCTIONS..... | 15 |
| GAS CONNECTION | 16 |
| VENT LOCATION | 17 |
| FITTING TOP SPACE+WALL CLIP | 17 |
| VENT TERMINATION CLEARANCES | 18 |
| LOCATION/CLEARANCES | 19 |
| SLEEVE AND MANIFOLD INSTALLATION..... | 21 |
| OPERATING INSTRUCTION LABEL | 25 |
| ADDITIONAL CUSTOMER OPERATING INFORMATION..... | 26 |
| PROGRAMMING ON/OFF TIMERS/CLOCK(556FTRA III ONLY) | 32 |
| OVERRIDE FUNCTION/USING THE REMOTE CONTROL(556FTRA III ONLY) .. | 36 |
| TESTING/CHECK..... | 37 |
| PRE-SERVICE CHECK..... | 38 |
| TROUBLE SHOOTING..... | 39 |
| ERROR MESSAGES..... | 40 |
| MAINTENANCE/SERVICE | 41 |
| WIRING DIAGRAM..... | 42 |
| WARRANTY INFORMATION..... | 43 |
| SCHEMATIC DIAGRAM/PARTS LIST | 45 |
| RHFE-556 FLOW DIAGRAM..... | 55 |
| EXTENDED FLUE PIPE KIT | 57 |

FEATURES OF THE RHFE-556FA III/FTRA III UNITS

- ◆ Clean Heating Forced Flue Type
- ◆ Easy Operation One-Touch Ignition
- ◆ Sensible Temperature Control Feature
- ◆ Comfortable Room Temperature Control and Display
- ◆ Warm Air Outlet at Floor Level (Keeps Your Feet Warm)
- ◆ Child Safety Lock
- ◆ Room Temperature Setting Memory
- ◆ Dirty Air Filter Indicator Lamp
- ◆ Energy-Saving Economy Setting
- ◆ Humidifier Tray
- ◆ Air Flow Directional Louvers
- ◆ Direct Vent Easily Installed
- ◆ Proportional Heating Variable Capacity
- ◆ Hush! Quiet Operation
- ◆ Modern Design Minimizes Floor Space Requirements
- ◆ Failure Message Display
- ◆ Dual Timers-556FTRA III only
- ◆ Timer Override Mode-556FTRA III only
- ◆ Pre-Heat Mode-556FTRA III only
- ◆ Remote Control-556FTRA III only

SAFETY DEVICES

Spark Safety Device: Automatically shuts unit down when there is an abnormal spark at time of ignition.

Flame Failure Device: Activated when burner flame fails. This prevents raw gas from being released.

Overheat Switch: This device automatically cuts the gas off if the heater exceeds a predetermined temperature. This is normally caused by an obstruction in front of the louvers, or a blocked fan filter.

Two Fusible Links: Backs up the overheat switch. If the fusible link cuts the unit off, a service call by an authorized person is required to replace the link.

Overcurrent Prevention Device: This is a 3 amp. glass fuse found on P.C. board. Design to shut unit down in case of overcurrent. If fuse blows all indicator lamps will be "OFF".

Power Outage Safety Device: This safety device cuts off gas passage and stops operation.

TECHNICAL DATA









| WEIGHT | DIMENSIONS | GAS RATE (BTU/h) | | | | | |
|---------|--|------------------|--------|--------|--------|--------|--------|
| | | INPUT | | | OUTPUT | | |
| 51 Lbs. | Width: 29 1/2" Height: 21 13/16" Depth: 9 13/16" | | NG | LP | | NG | LP |
| | | LOW | 8,200 | 8,200 | LOW | 6,640 | 6,640 |
| | | HIGH | 21,500 | 20,700 | HIGH | 17,420 | 16,770 |
| | | | | | | | |

Burner Orifices:

RHFE-556FA III/FTRA III-P use: Orifice part #AU129-210×02-0.85(0.033")



RHFE-556FA III/FTRA III-N use: Orifice part #AU129-210×02-1.13(0.044")

GAS CONVERSION SPECIFICATIONS

| MODEL | GAS TYPE | DIAMETER OF ORIFICE(mm) | PRIMARY DAMPER | SECONDARY DAMPER | MANIFOLD DIFFERENTIAL PRESSURE (W.C.) | | DIP SWITCH POSITION |
|------------------|----------|-------------------------|----------------|---------------------------|---------------------------------------|----------|---|
| | | | | | HI | LO | |
| RHFE-556FA III | LPG | φ0.85 | 556F-209-15 | 556F-208-5 (φ2.5×15) | 4.5"W.C. | 0.8"W.C. | ON  OFF  |
| RHFE-556FA III | NG | φ1.13 | 556F-209-7 | 556F-208-7 (33×47hole) | 3.8"W.C. | 0.7"W.C. | ON  OFF  |
| RHFE-556FTRA III | LPG | φ0.85 | 556F-209-15 | 556F-208-5 | 4.5"W.C. | 0.8"W.C. | ON  OFF  |
| RHFE-556FTRA III | NG | φ1.13 | 556F-209-7 | 556F-208-7 | 3.8"W.C. | 0.7"W.C. | ON  OFF  |

GAS PRESSURE SETTING PROCEDURE

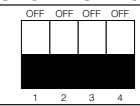
1. Check and ensure SW6 Dip Switches are correct for the gas type for which the appliance is to be used. (Refer to diagram below.)

| | | SW6 DIP SWITCH |
|------------------------|-----|---|
| 556FA III/ FTRA III | NG |  |
| | LPG |  |

2. There are two test points, one on the manifold, one on the gas control assembly. Connect pressure gauge to both test points. Using an electronic manometer, connect the ⊖ side to the manifold test point. (Refer to data plate for pressure.)

GAS SUPPLY PRESSURE

| | NATURAL | PROPANE |
|---------|-----------|---------|
| MINIMUM | 5"W.C. | 8"W.C. |
| MAXIMUM | 10.5"W.C. | 13"W.C. |

3. Press the ON/OFF button to operate the appliance.
4. With appliance operating, press SW5 once.
5. Press SW4 to operate appliance on forced low. Adjust the setting to the correct pressure using the "▲" and "▼" buttons on the control panel.
6. Press SW4 again to lock in the selected setting.
7. Press SW3 to operate appliance on forced high. Adjust the setting to the correct pressure using the "▲" and "▼" buttons on the control panel.
8. Press SW3 again to lock in the selected setting.
9. Press SW5 once to return heater to normal operation.
10. Press the ON/OFF button to turn the appliance off.
11. Remove the gauge from the test points and replace the test point screws.
12. Test for gas escapes.

- The minimum and maximum inlet gas supply pressures are for the purpose of input adjustment.
- Heaters may be converted from one gas to another using Rinnai conversion kits. (See page 62)

IMPORTANT POINTS / USAGE AND INSTALLATION MUSTS

Unpack heater and check for damage. (DO NOT INSTALL DAMAGED HEATER.) If heater is damaged, contact your supplier for advise. Before installing a heater, check the label for the correct gas type (see label on side of heater). Refer to local gas authority for confirmation of gas type if you are in doubt.

Included in Carton:

- Customers Operating Information
- Conversion kits

IMPORTANT

Before using this product, please read this manual carefully to insure proper use of product.

1. The installation must conform with local codes or, in absence of local codes, the National Fuel Gas Code, ANSI Z223.1 or the Canadian Installation Code, CAN/CGA-B149.
2. For information on gas type, see data plate on the appliance.
3. This heater must not be installed where curtains or other combustible materials could come into contact with it. In some cases curtains may need restraining.
4. This appliance is not designed to be built in.
5. If you move, check the gas type in the area where you are moving to. The local gas authority will be able to advise on local regulations.
6. This heater discharges a large volume of warm air at low level to provide even heat distribution. If the air in the room contains cooking vapor or cigarette smoke, and the heater is used on a carpet, the surface of the carpet may become discolored. In addition, some nylon carpets contain dyes which may be affected by the warm air flow. Some soft vinyl surfaces are also subject to distortion, or discoloration by warm air. To prevent discoloration of carpets, etc., a mat should be placed under the appliance, extending about 30" (750mm) in front of it.

Diagram shows minimum clearances from combustible materials.

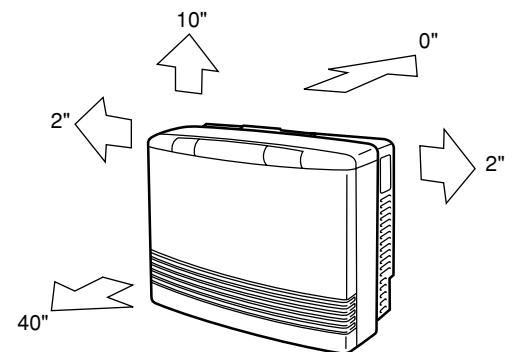

7. Read these rules and the instructions carefully. Check all local codes. Failure to follow these could cause a malfunction of the heater resulting in death, serious bodily injury and/or property damage.
8. This appliance is only for use with the type of gas indicated on the rating plate. This appliance is not convertible for use with other gases, unless a certified kit is used.
If a conversion of the unit is needed, conversions must be performed at Rinnai America or authorized agent at owner's expense.
9. **WARNING:** Any change to this heater or its controls can be dangerous.
10. If a gas leak is suspected, turn heater off, turn gas supply valve off at appliance connector valve. Open windows to ventilate area immediately and contact your dealer or gas company.

11. DO NOT PLACE CLOTHING OR FLAMMABLE MATERIALS, GASOLINE AND OTHER FLAMMABLE VAPORS AND LIQUIDS, ON OR NEAR THE HEATER.
12. YOUNG CHILDREN SHOULD BE CAREFULLY SUPERVISED WHEN THEY ARE IN THE SAME ROOM WITH THE HEATER.
13. LPG containers must not be installed indoors.
14. Do not use this room heater if any part has been under water. Immediately call a qualified service technician to inspect the room heater and to replace any part of the control system and any gas control which has been under water.
15. Adequate clearances for accessibility for purposes of servicing and proper operation should be provided.
16. Adequate clearances around air openings should be provided.
17. Do not install in areas where curtains, drapes, clothing, or other moving flammables are within 12 inches of this unit.
18. Periodic examination of the venting system is required.
19. The flow of combustion and ventilation air should not be obstructed.
20. A manufactured home (USA only) or mobile home OEM installation must conform with the Manufactured Home Construction and Safety Standard, Title 24CFR, Part 3280, or, when such a standard is not applicable, the Standard for Manufactured Home Installations, ANSI Z225.1 or Standard for Gas Equipped Recreational Vehicles and Mobile Housing, CSA Z240.4.
21. "This appliance must be installed in accordance with the current standard CSA Z240.4 GAS EQUIPPED RECREATIONAL VEHICLES AND MOBILE HOUSING. Cet appareil doit être installé conformément aux exigences de la norme Z240.4 en vigueur de l'ACNOR, Installations de gaz dans les constructions mobiles et véhicules récréatifs."
22. If a blockage occurs at vent terminal due to snow, leaves or other type of obstruction the unit will stop working. The unit will not function until blockage has been removed then if unit fails to operate, contact a qualified service agency.
23. For a manufactured home (USA only) or mobile home OEM or residential or light commercial installation, this unit has been designed and certified to be converted from natural gas to propane or vice-versa. When provisions are being made to convert this unit, a certified conversion kit must be used. You must also readjust manifold gas pressure to specifications indicated in the conversion manual. If in doubt, contact Rinnai America for assistance.



GENERAL INFORMATION

THIS SERIES HEATER IS DESIGN CERTIFIED BY CSA INTERNATIONAL AS A DIRECT VENT WALL FURNACE AND MUST BE INSTALLED ACCORDING TO THESE INSTRUCTIONS. ALTERATION OF THE ORIGINAL DESIGN INSTALLED OTHER THAN AS SHOWN IN THESE INSTRUCTIONS OR USED WITH A TYPE OF GAS NOT SHOWN ON THE RATING PLATE, IS THE RESPONSIBILITY OF THE PERSON AND COMPANY MAKING THE CHANGE.

- Rinnai is continually updating and improving products. Therefore, specifications are subject to change without notice.
- Thank you for purchasing Rinnai forced flue gas heater.
- Please read the warranty thoroughly and keep it in a safe place.

DIMENSIONS

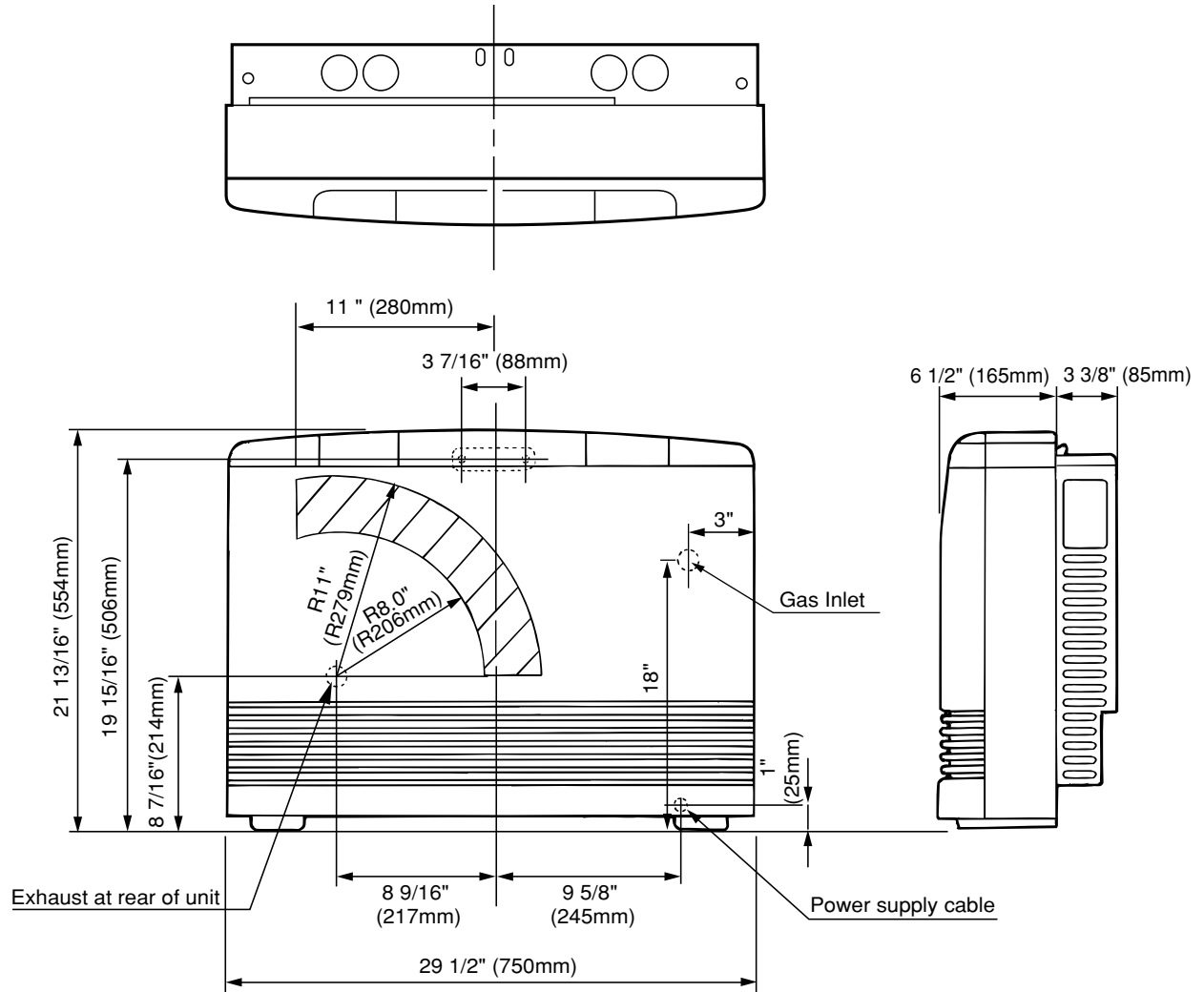

SPECIFICATIONS

| MODEL # | BTU/h | | MIN. CLEARANCES | | | FAN CFM OUTPUT |
|-----------------------------|----------------|----------------|-----------------|----------------|-------------|----------------|
| | INPUT | OUTPUT | SIDE | TOP | FRONT | |
| RHFE-556FA III /FTRA III | Low 8,200 | Low 6,640 | 2" (50mm) | 10" (250mm) | 40" (1m) | LO:110.5 |
| NATURAL | High 21,500 | High 17,420 | | | | HI:162.7 |
| RHFE-556FA III /FTRA III | Low 8,200 | Low 6,640 | 2" (50mm) | 10" (250mm) | 40" (1m) | LO:110.5 |
| PROPANE | High 20,700 | High 16,770 | | | | HI:162.7 |

SPECIFICATIONS

| | |
|---------------------|---|
| Type of Appliance | Fan forced flued gas furnace |
| Model | RHFE-556FA III/FTRA III ENERGY SAVER |
| Dimensions | Width— (750mm) 29 1/2" Depth—(250mm with back spacer)9 13/16" (with back spacer) Height—(554mm) 21 13/16" |
| Weight | Approx. 51 lbs. |
| Connections | Electrical—AC 120V 60Hz 52 watts Gas—1/2" female NPT |
| Combustion System | Stainless steel bunsen burner |
| Ignition System | Continuous spark |
| Operation | Finger touch control buttons (non-lock) |
| Temperature Control | Electronic thermostat HI-LOW/OFF Up/down switch |
| Temperature Range | Modulates Continuous LOW=55°F 60°F~80°F HI=High Combustion |
| Warm Air Outlet | Bottom front louver |
| Indicators/Lamps | Burner ON, child lock, filter, economy, temperature display, Timers(FTRA III Only) |
| Operating Buttons | On, Up/down, child-lock, economy/Timers, Override (FTRA III Only) |
| Economy Mode | Energy saving feature |
| Humidifier Tray | Capacity—3 pints (1300cc) |

| | | |
|-----------------------------|---|------------------------------|
| Safety Devices | Flame failure – Flame rod Over heat – Bi-metal switch, thermal fuse, thermistor Power failure – PCB Power surge – 3 Amp. fuse Fan delay – Micro computer timer Pre-purge – Combustion fan, pre-purge timer, spark sensor Room over heat – Automatic cut off at 104°F after 10 minutes | |
| Noise Level Range | HI~LOW=41~32dB(A) | |
| TYPE | Combustion Method | Forced combustion |
| | Air Supply Exhaust | Closed Type |
| | Radiation Method | Forced convection |
| AIR SUPPLY/ EXHAUST PIPE | Wall Penetration Hole | (80mm) 3 1/8" |
| | Max. Extended Length | (4m, 2 bends)=13ft., 2 bends |

| SPECIFICATIONS FOR VENT SIZES | | |
|-------------------------------|---------------------------------|------------------------|
| S | 3"—4 1/2" (75—115)mm | Thin Walls Mobile Home |
| A | 4 1/2"—9 1/2" (115—240)mm | Wood Walls |
| B | 9 1/2"—15 3/4" (240—400)mm | Wood/Brick |
| C | 15 3/4"—23 5/8" (400—600)mm | Brick/Block |
| D | 23 5/8"—31 1/2" (600—800)mm | Special |

** BTU - Efficiency increases with vent Extension. Clearances from combustibles see pages 6 and 28.

** Thermal efficiency rating determined under continuous operating conditions, and was determined independently of any installed system.

SAFETY POINTS

Do not restrict the warm air discharge by placing articles in front of the heater.

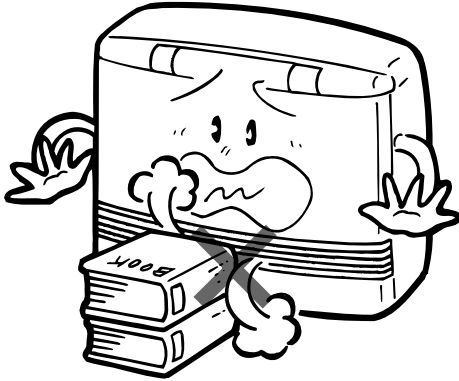

This appliance must not be used for any purpose other than heating.

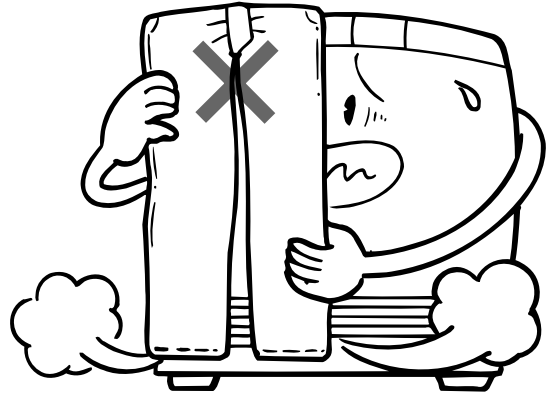

Do not spray aerosols while the heater is operating. Most aerosols contain butane gas, and can be a fire hazard if used near this heater when it is in use.

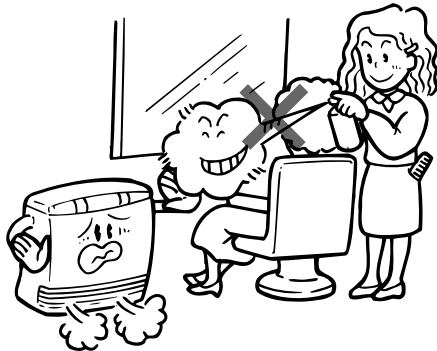

Do not install the heater in an unusually dusty area.

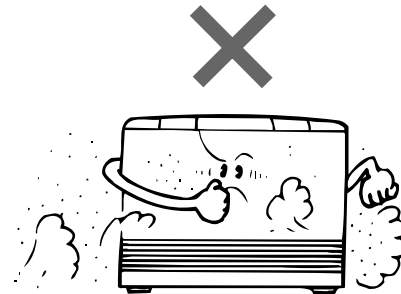

Do not allow curtains or other flammable or combustible materials to come into contact with the heater.

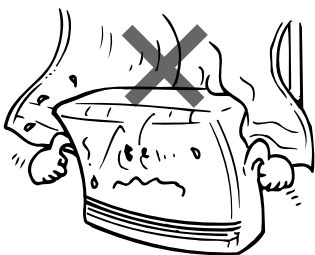

Combustible materials must not be placed where the heater could ignite them.

Do not allow anyone to sit on or lean against the appliance.



SAFETY POINTS

Keep flammable materials, trees, shrubs, etc., away from the flue terminal.

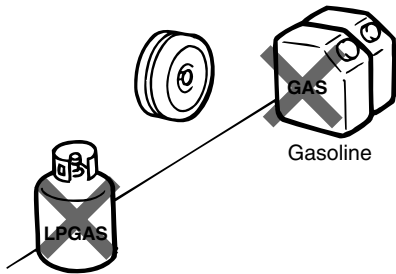

Do not allow anyone to poke articles through the louvers.

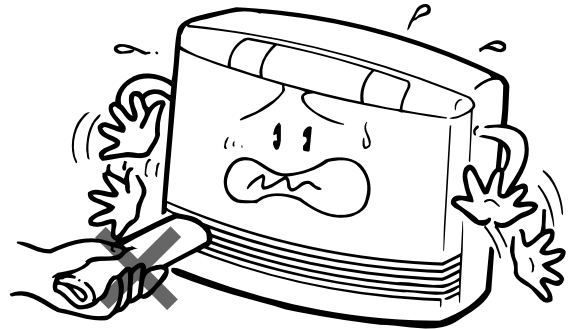

Filter should be cleaned at regular intervals. See page 31.

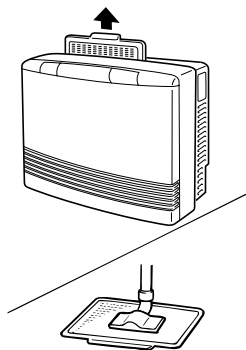

Clean as needed.

Young children should be supervised at all times. Hand or body contact with the louvers should be avoided.

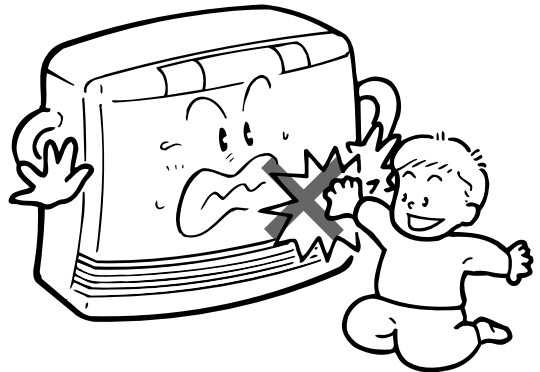

Do not place articles containing liquids on top of the heater. Liquids spilled on the controls may cause extensive damage.

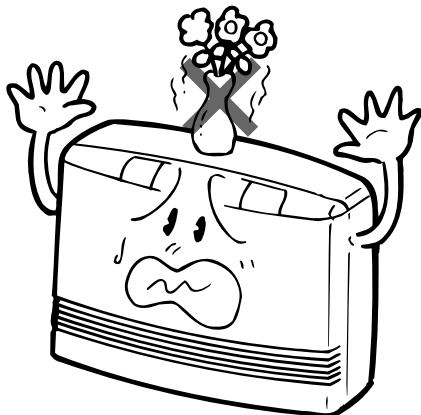

Do not allow young children or an infant to sleep directly in front of the heater.

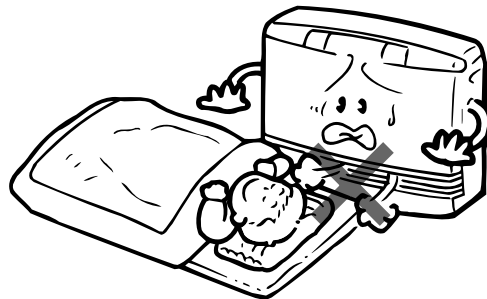

GETTING TO KNOW YOUR NEW RHFE-556

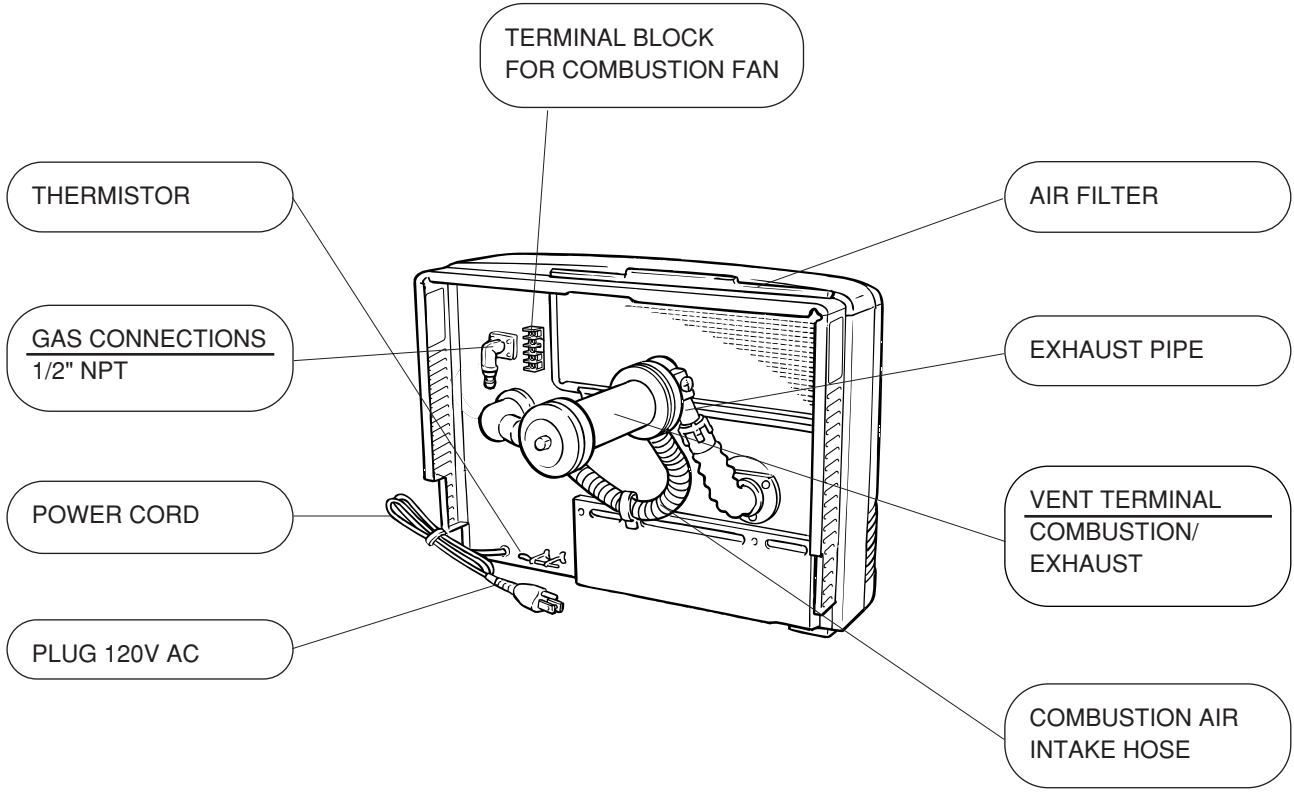
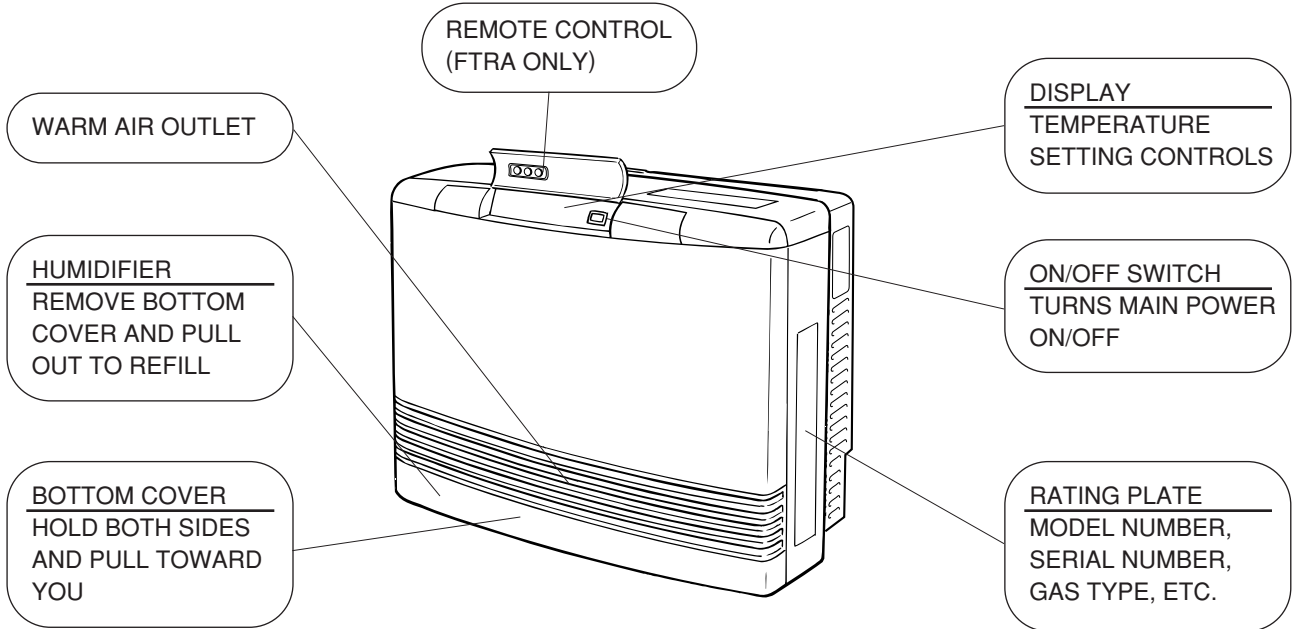

CONTROL PANEL LAYOUT

■ ALL BUTTONS BEEP WHEN OPERATED.

<RHFE-556F III>

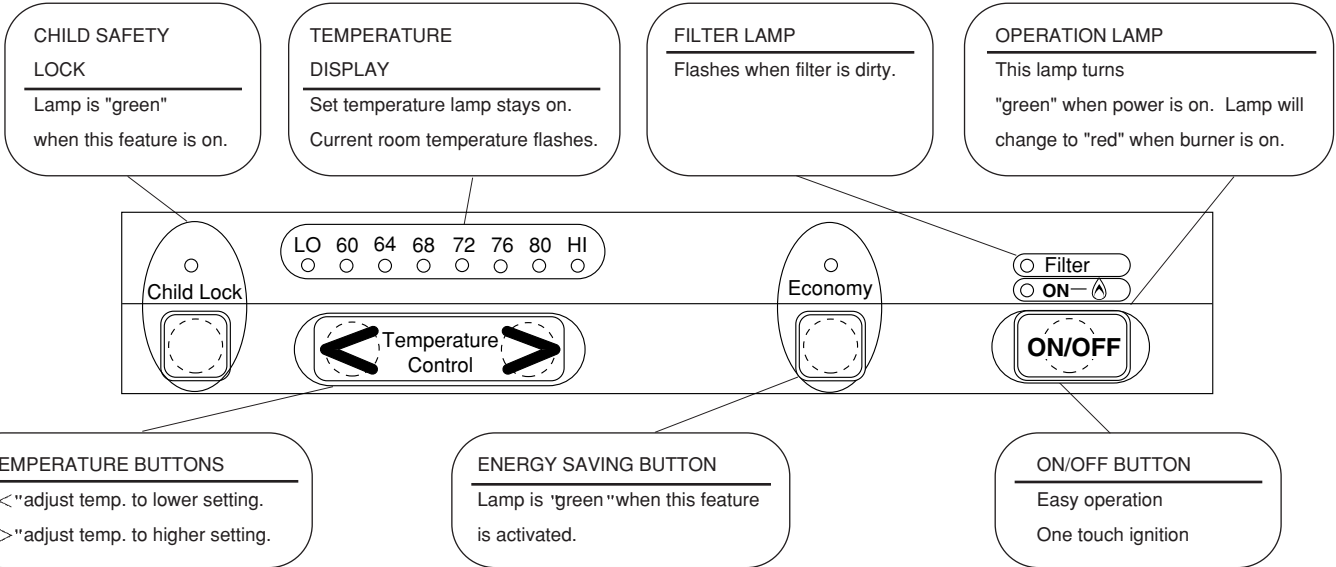

<RHFE-556FTRA III>

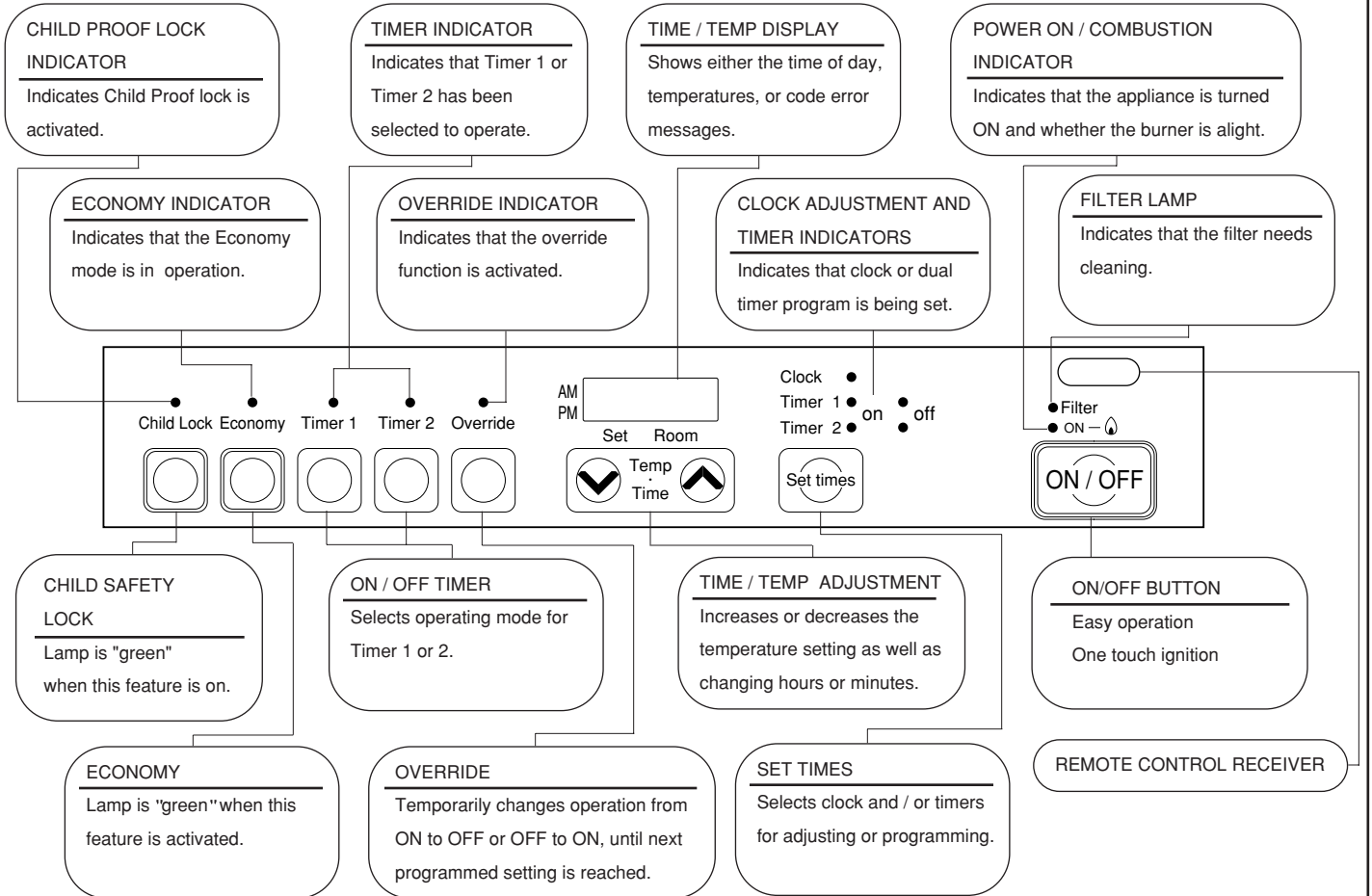

REMOTE CONTROL

TO REPLACE BATTERY

Simply open the back of the remote control and replace Lithium battery.
TYPE: CR2032

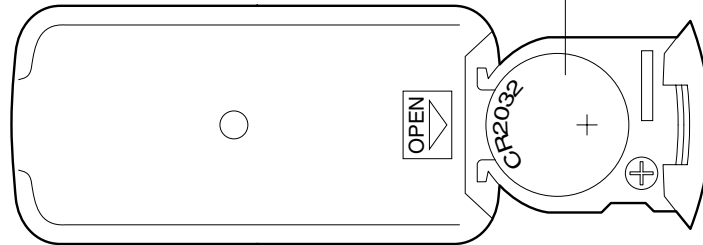

REVERSE

ON BUTTON

Operates the heater manually.

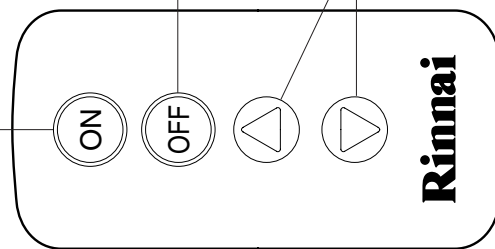

OFF BUTTON

Stops heater manually.

TEMPERATURE ADJUSTMENT

Increases or decreases the temperature setting.

FRONT

NOTE

- Some fluorescent lights may interfere with the transmission of remote control signals, in this case changing the position from which you are operating the remote control may help.
- Avoid leaving the remote control in direct sunlight and do not place the remote close to the louvers of the heater.
- Avoid getting the remote control wet, or dropping it.
- The remote control works within 16 feet and an angle of 20° to the receiver on the heater.
- Only use the battery type specified. (CR2032).
- Remove battery if control is not going to be used for a long period. This will help to avoid damage from leaking batteries.

CUT-AWAY DIAGRAM

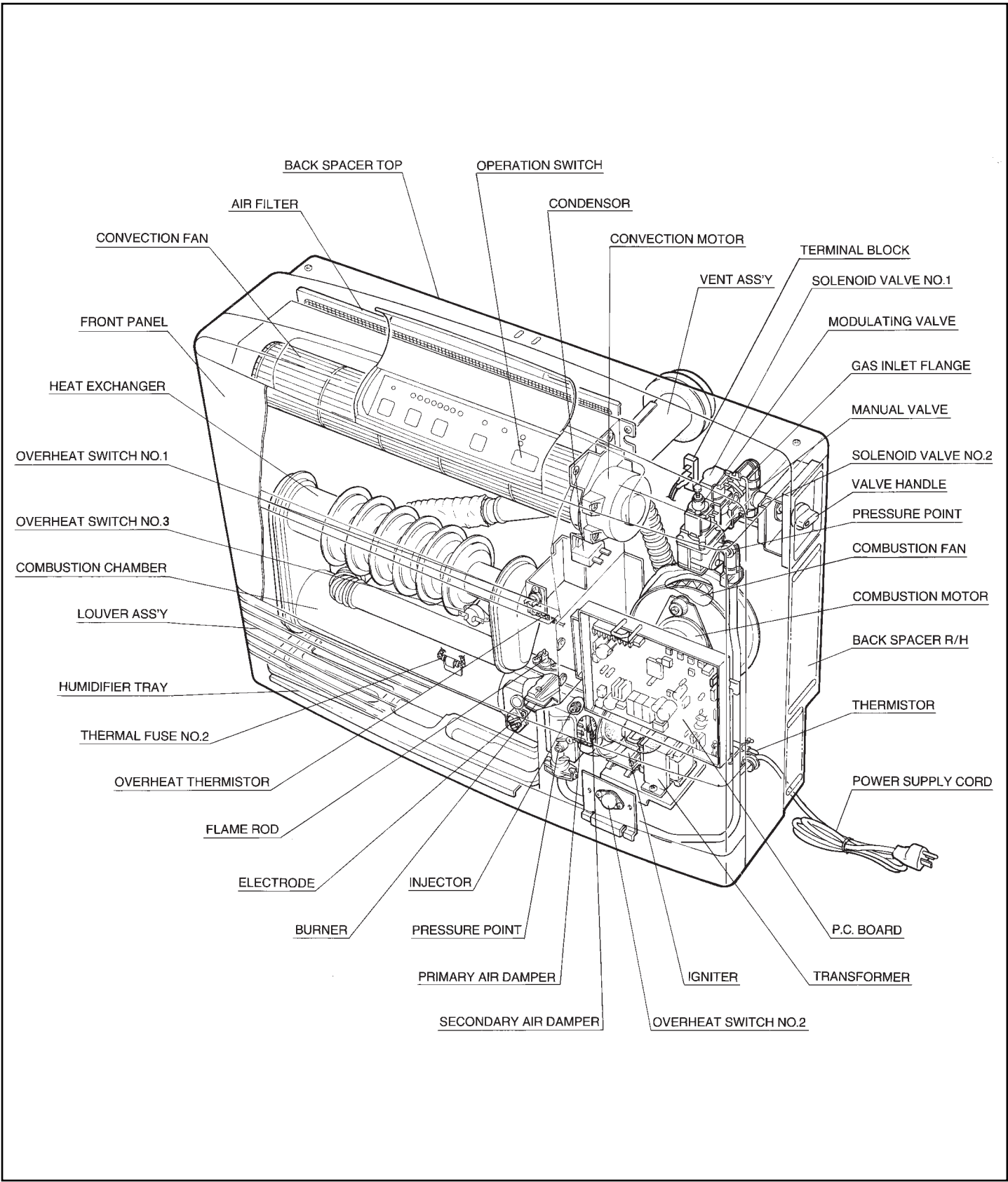

NOTICE BEFORE INSTALLATION

The heater must be installed by a qualified service person according to this installation instruction.

Check your local building codes for the proper method of installation. In the case of absence of local codes, this heater should be installed in accordance with the National Fuel Gas Code ANSI Z223—1.

Check local codes or, in the absence of local codes, the current CAN/CGA—B149 INSTALLATION CODE.

DUE TO HIGH TEMPERATURES, THE APPLIANCE SHOULD BE LOCATED OUT OF TRAFFIC AND AWAY FROM FURNITURE AND DRAPERIES.

CHILDREN AND ADULTS SHOULD BE ALERTED TO THE HAZARDS OF HIGH SURFACE TEMPERATURES AND SHOULD STAY AWAY TO AVOID BURNS OR CLOTHING IGNITION.

“WARNING” Do not operate appliance with the panel(s) removed, cracked or broken. Replacement of the panel(s) should be done by a licensed or qualified service person.

INSTALLATION AND REPAIR SHOULD BE DONE BY A QUALIFIED SERVICE PERSON. THE APPLIANCE SHOULD BE INSPECTED BEFORE USE AND AT LEAST ANNUALLY BY A QUALIFIED SERVICE PERSON. MORE FREQUENT CLEANING MAY BE REQUIRED DUE TO EXCESSIVE LINT FROM CARPETING, BEDDING MATERIAL, ETC. IT IS IMPERATIVE THAT CONTROL COMPARTMENTS, BURNERS AND CIRCULATING AIR PASSAGEWAYS OF THE UNIT BE KEPT CLEAN.

The appliance, when installed, must be electrically grounded in accordance with local codes or, in the absence of local codes, with the National Electrical Code, ANSI/NFPA 70 or Canadian Electrical Code, CSA C22.1, if an external electrical source is utilized.











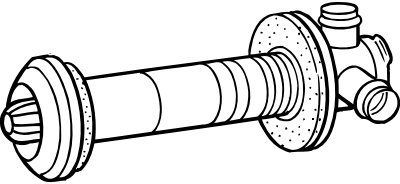

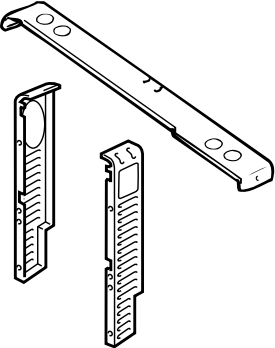

WARNING: THIS APPLIANCE IS EQUIPPED WITH A THREE-PRONG (GROUNDING) PLUG FOR YOUR PROTECTION AGAINST SHOCK HAZARD AND SHOULD BE PLUGGED DIRECTLY INTO A PROPERLY GROUNDED THREE-PRONG RECEPTACLE. Do not cut or remove the grounding prong from the plug.

This gas appliance must not be connected to a chimney flue serving a separate solid-fuel burning appliance. When the appliance is installed directly on carpeting, tile or other combustible material other than wood flooring, the appliance shall be installed on a metal or wood panel extending the full width and depth of the appliance.

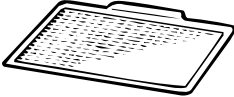
Rinnai recommends a dedicated electrical circuit.

Appliance input ratings are based on sea level operation and need not be changed for operation up to 2,000 feet elevation. For operation at elevations above 2,000 feet, manufactured to specified deration conditions for Canada and the United States.

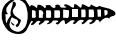
INSTALLATION INSTRUCTIONS

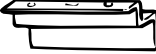
| | | | | | |
|---|--|---|---------------------------|---|---|
| Flue Manifold1 | | Spare rubber seal1 (‘A’ Flue units only) | | | |
|  | |  | | | |
| (For weatherboard installations) | | | | | |
| Back Spacer Set |  | 1 | Flue Locking Clamp |  | 1 |
| | | | Flue Lock Stopper |  | 1 |
| | | | Insulation Clip |  | 1 |
| | | | Hose Clip |  | 2 |
| Customers operating information and Installation Instructions | | 1 | Plastic tie for air inlet |  | 1 |
| Air Filter |  | 1 | (M4 X20) |  | 1 |
| (M4) |  For Back Spacer Set | 6 | (M4) |  | 3 |
| (M4) |  For Air Intake Clip | 2 | (M4.8 X32) Wood Screws |  | 5 |
| Wall Bracket |  | 1 | Spacer Bracket |  | 1 |

Check to ensure gas supply matches that of the appliance.
Refer to local gas authority for confirmation of gas type if in doubt.
Refer to data plate located inside of the front panel.
Check for damage, if the unit is damaged contact your supplier or Rinnai.
Do not install a damaged unit before checking with your supplier.
Refer to an approved pipe sizing chart if in doubt about size of gas line.

GAS CONNECTION

1. The gas supply line shall be gas-tight, sized and so installed as to provide a supply of gas sufficient to meet the maximum demand of the heater without loss of pressure.
2. A shut off valve (and appliance connector valve) should be installed in the upstream of the gas line to permit servicing.
3. Flexible pipe and any appliance connector valve used for gas piping shall be types approved by nationally recognized agencies.
4. Any compound used on the threaded joint of the gas piping shall be a type which resists the action of liquefied petroleum gas.
5. Supplied gas pressure must be within the limits shown in the specifications.
6. After completion of gas pipe connections, all joints including the heater must be checked for gas tightness by means of leak detector solution, soap and water, or an equivalent nonflammable solution, as applicable.

CAUTION: Since some leak test solutions, including soap and water, may cause corrosion or stress cracking, the piping shall be rinsed with water after testing, unless it has been determined that the leak test solution is noncorrosive.

7. The appliance and its appliance main gas valve must be disconnected from the gas supply piping system during any pressure testing of that system at test pressures in excess of 1/2 P.S.I (3.5kPa).

The appliance must be isolated from the gas supply piping system by closing its individual manual shut off valve during any pressure testing of the gas supply system at test pressures equal to or less than 1/2 psig.

8. Two 1/8" test plugs are provided for testing of manifold pressure see schematic for location.

At time of installation installer must supply a 1/8" N.P.T. plugged tapping, accessible for test manometer connection, immediately up stream of the gas supply connection to the appliance.

VENT LOCATION

FLUE MANIFOLD POSITION

Center of hole for flue manifold can be drilled anywhere within the shaded area. (To avoid studs, etc.)

FOR WEATHERBOARD WALLS DRILL THROUGH CENTER OF WEATHER BOARD FROM OUTSIDE, THEN DRILL FROM INSIDE THROUGH PLASTER-BOARD.

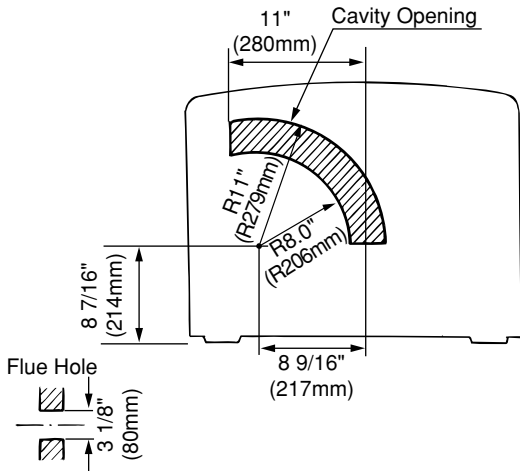

Before drilling the flue hole, check for water and gas pipes as well as electric cables. Use a 3 1/8" (80mm) drill for hole through wall.

WALL MOUNTING BRACKETS

Place top back spacer in position. Mark the position of the top edge of the top space on the wall. Move the heater away from the wall. Mark center lines 1 1/8" (30mm) down from the top edge mark, and 1 9/16" (40mm) in front the left and right hand sides of the top spacer. Attach wall brackets at the marked position.

FITTING TOP SPACER + WALL CLIP

Tighten all screws.

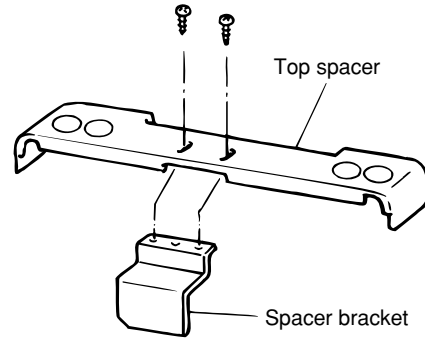

SECURE HEATER TO WALL

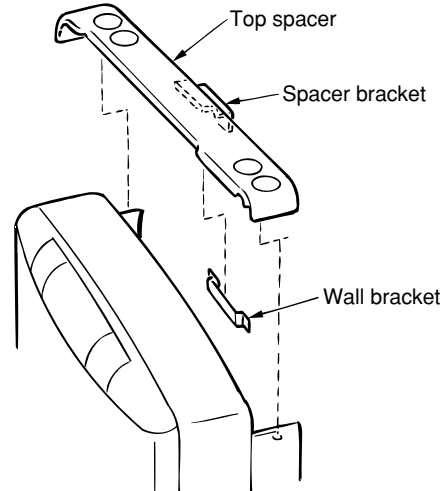

Replace top spacer, clipping the spacer into the wall brackets at the same time as attaching it to the heater. Secure top spacer with the screws provided. THE HEATER IS NOW SECURED TO THE WALL.

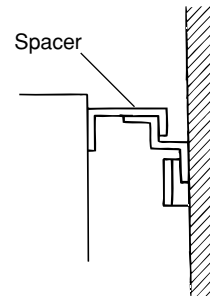

Replace fan filter.

VENT TERMINATION CLEARANCES

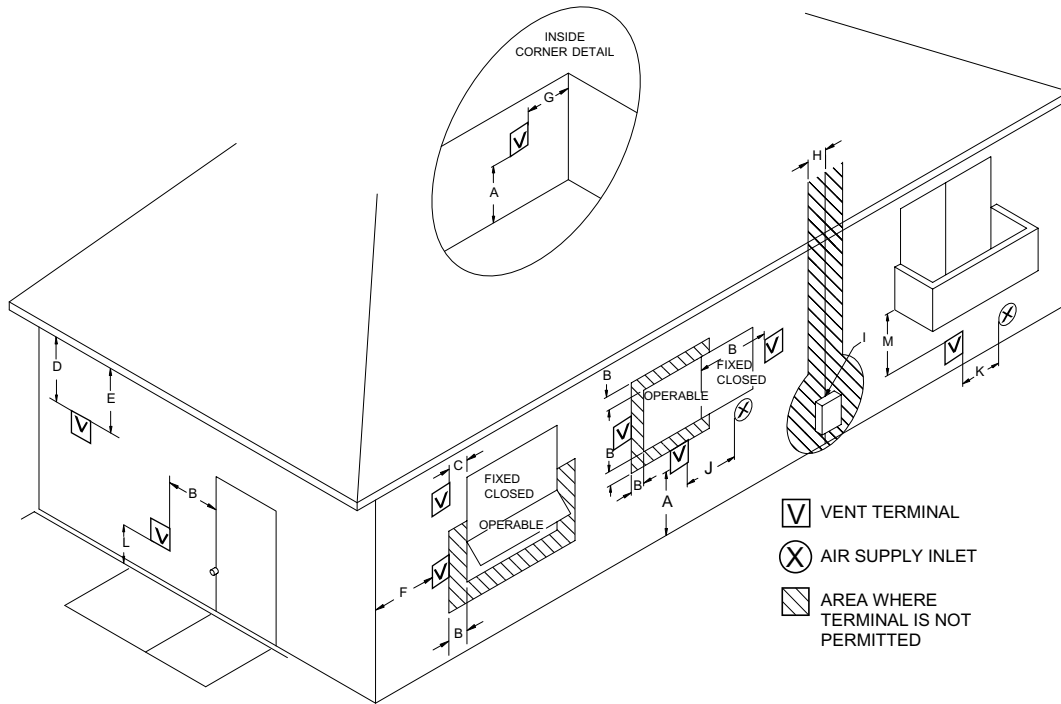

| REF | DESCRIPTION | U.S. Installations | Canadian Installations |
|-----|--|---|---|
| A | Clearance above grade, veranda, porch, deck, or balcony | 1 foot | 1 foot |
| B | Clearance to window or door that may be opened | ** 6 inches for appliances $\leq 10,000$ Btuh, 9 inches for appliances $> 10,000$ Btuh and $\leq 50,000$ Btuh, 12 inches for appliances $> 50,000$ Btuh | 6 inches for appliances $\leq 10,000$ Btuh, 12 inches for appliances $> 10,000$ Btuh and $\leq 100,000$ Btuh, 36 inches for appliances $> 100,000$ Btuh |
| C | Clearance to permanently closed window | * | * |
| D | Vertical clearance to ventilated soffit, eaves, or overhang | * | * |
| E | Clearance to unventilated soffit, eaves, or overhang | * | * |
| F | Clearance to outside corner | * | * |
| G | Clearance to inside corner | * | * |
| H | Clearance to each side of center line extended above meter/regulator assembly | * | 3 feet within a height 15 feet above the meter/regulator assembly |
| I | Clearance to service regulator vent outlet | * | 3 feet |
| J | Clearance to nonmechanical air supply inlet to building or the combustion air inlet to any other appliance | ** 6 inches for appliances $\leq 10,000$ Btuh, 9 inches for appliances $> 10,000$ Btuh and $\leq 50,000$ Btuh, 12 inches for appliances $> 50,000$ Btuh | 6 inches for appliances $\leq 10,000$ Btuh, 12 inches for appliances $> 10,000$ Btuh and $\leq 100,000$ Btuh, 36 inches for appliances $> 100,000$ Btuh |
| K | Clearance to a forced air inlet into a building | 3 feet above if within 10 feet horizontally | 6 feet |
| L | Clearance above paved sidewalk or paved driveway located on public property | * | † 7 feet |
| M | Clearance under deck, veranda, porch, or balcony (open on 3 sides) | * | ‡ 1 foot |

* For clearances not specified in ANSI Z223.1 / NFPA 54 or CAN/CGA-B149, use clearances in accordance with local installation codes and the requirement of the gas supplier.

† A vent shall not terminate directly above a sidewalk or paved driveway that is located between two single family dwellings and serves both dwellings.

‡ Permanent only if veranda, porch, deck, or balcony is fully open on a minimum of two sides beneath the floor.

** 4 feet for units other than Direct-Vent Appliance.

LOCATION / CLEARANCES

When positioning the heater the main points governing the location are:

1. Flueing
2. Warm air distribution

This heater is not designed to be build in.

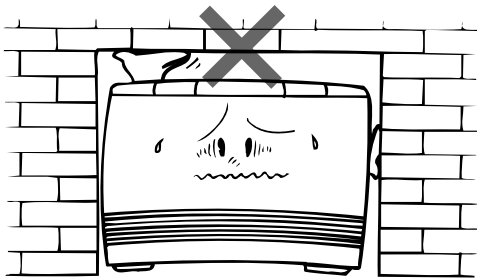

The flue terminal should be positioned away from flammable materials.

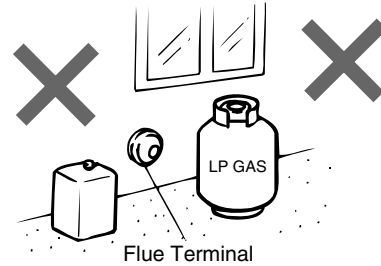

Do not flue into natural draught flues or fireplaces, this unit can only be used with one of the five types of Rinnai flue kits. Do not flue unit into other rooms. Flue terminal must be outside.

The flue is not designed to be positioned under floors, or below the level of the heater.

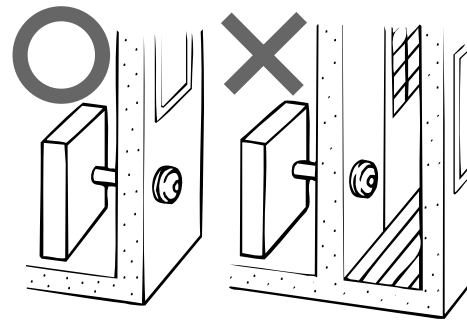
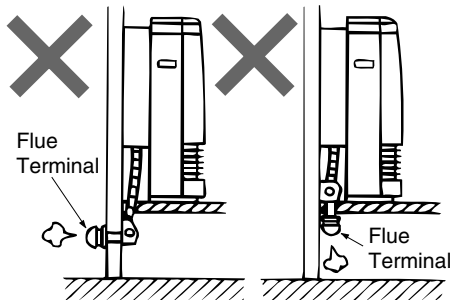

Flue may be positioned directly under opening windows, with a minimum clearance of 9" (230mm).

FLUE SIZES:

5 Flue lengths are available.

- S flue walls 3"~4 1/2" (75~115mm)
- A flue walls 4 1/2"~9 1/2" (115~240mm)
- B flue walls 9 1/2"~15 3/4" (240~400mm)
- C flue walls 15 3/4"~23 5/8" (400~600mm)
- D flue walls 23 5/8"~31 1/2" (600~800mm)

SNOW AREAS

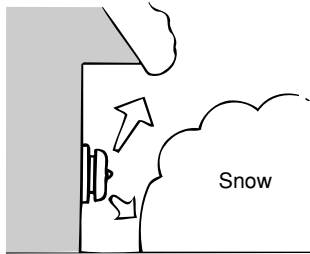

In areas subject to heavy snowfall, keep snow clear of flue terminal at all times.

STANDARD INSTALLATION OF FLUE MANIFOLD.

Diagram below shows minimum clearances and distances from obstructions. Also check local regulations.

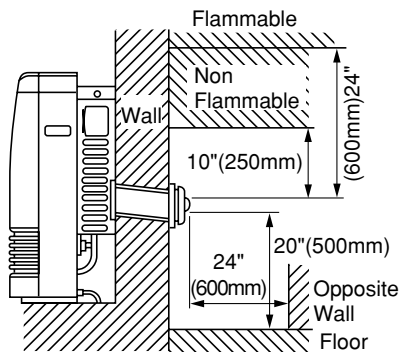

Side Clearances

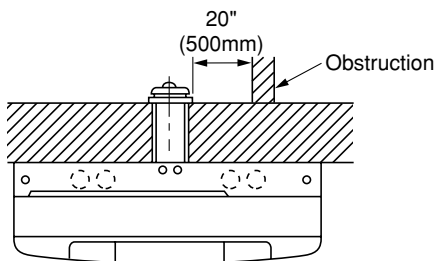

FIT BACK COVERS (SIDES ONLY)

Fit back covers (sides only) as shown below.

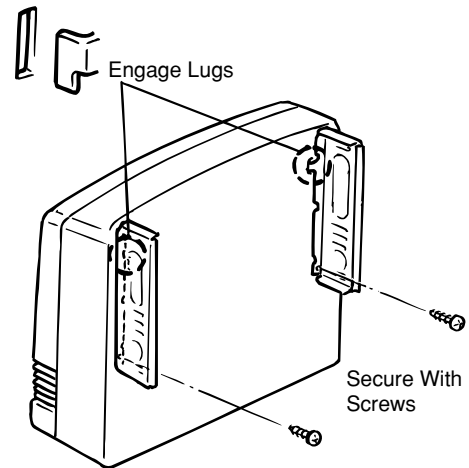

Clearance in accordance with local installation codes and the requirements of the gas supplier.

SLEEVE AND MANIFOLD INSTALLATION

METHOD FOR STANDARD WALLS

1. Disassemble Manifold from Sleeve.

The flue consists of 3 parts, sleeve, inside connectors and tube, outside terminal; (dis-assembly by pulling hard on outside terminal and inner connections, then pull sleeve off outer terminal.)

NOTE: Clearance to combustibles for terminal assembly sleeve and flanges is 0".

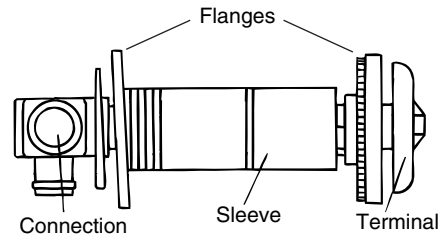

2. Adjustment of Sleeve Length.

Measure wall thickness through previously drilled 3 1/8" (80mm) hole. End of sleeve should protrude 3/16"~3/8" (5~10mm) from outside wall. Adjust sleeve length to wall thickness plus 3/16"~3/8" (5~10mm). (Sleeve is threaded for adjustment.) Do not extend beyond red line.

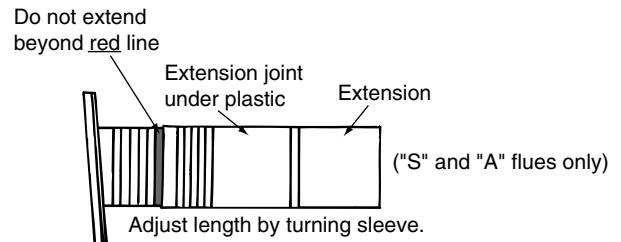

3. For S and A flue only.

Depending on flue set and wall thickness extension piece "C" may need to be removed. Cut plastic, remove extension, then follow instruction 2. This applies to "S" and "A" flues only. There is no extension on other flues, they can be fully adjusted by turning the threaded section.

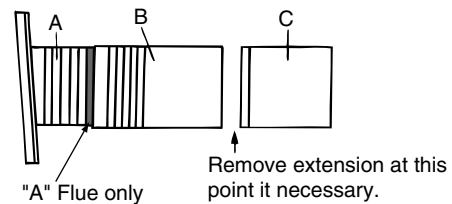

4. Fixing Sleeve.

Fix to the wall, using the 3 screws provided.

NOTE: The flange is marked "TOP", sleeve must be fitted with this mark **Up**. Check sleeve protrudes 3/16"~3/8" (5~10mm) on the outside.

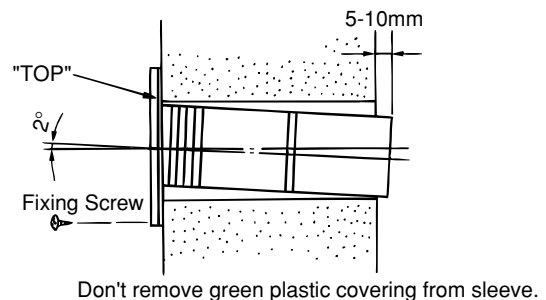

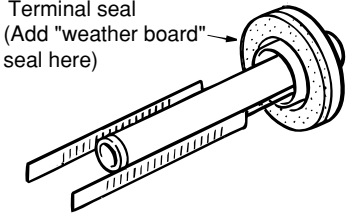
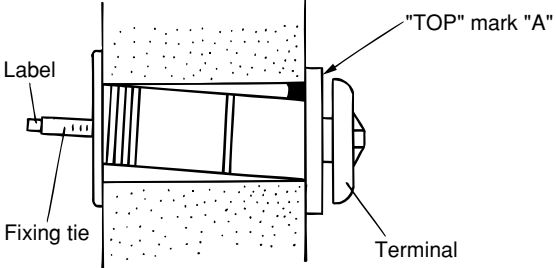
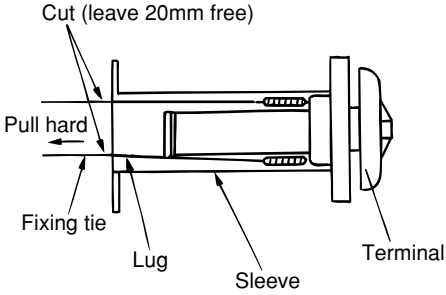
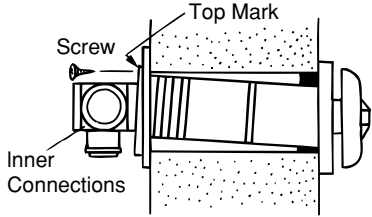
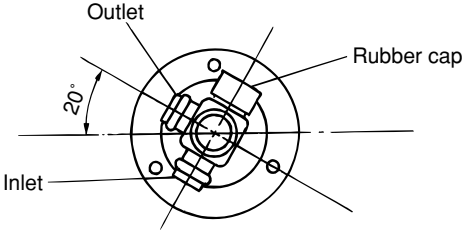
| | |
|--|--|
| <p>5. Check rubber seal is in place on terminal.</p> <p>*For weather board walls, add spare rubber seal provided to compensate for weather board angle.</p> |  |
| <p>6. Installation of Terminal</p> <p>From outside, insert terminal into sleeve with the “A” mark at the top. Left hand side fixing tie is marked “LEFT” (from inside).</p> |  |
| <p>7. Attached Ties</p> <p>Pull hard on left and right hand side ties, clip ties over lugs inside sleeve. You should be able to pull ties 2 or 3 slots past the starting point. Cut the ties, leaving about 3/4" (20mm) past the lugs. Bend ties so they are parallel with the wall.</p> |  |
| <p>8. Insert Inner Connection Assembly.</p> <p>Push assembly into the terminal tube, make sure “TOP” mark is uppermost. Fix with 3 screws provided.</p> |  |
| <p>9. Manifold can still be turned after attaching.</p> |  |

FITTING UNIT

AIR INLET HOSE

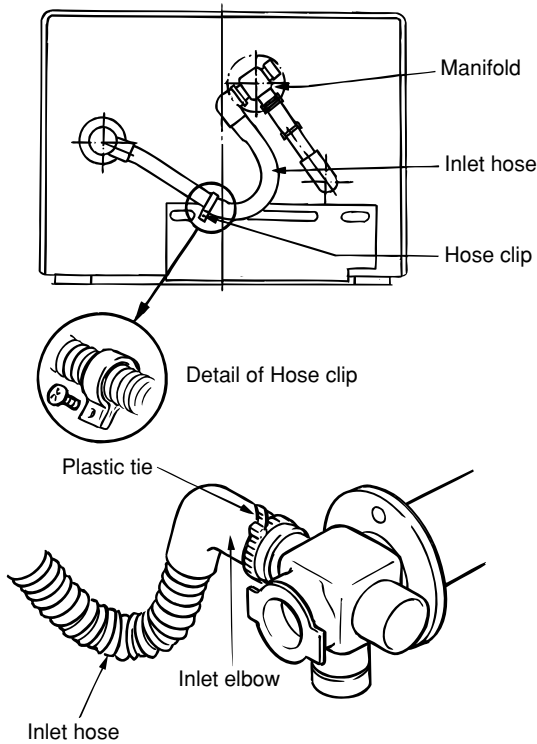

When servicing unit replace plastic tie with new one. (Available at local hardware store or contact local distributor.)

LOCKING CLAMP SCREW CLAMP AND INSULATION.

The following components can be fitted by reaching down the rear of the appliance as it is positioned against the wall.

1. Connect the flue outlet to the manifold by extending the stainless steel sliding tube until it is fully inserted into the manifold.

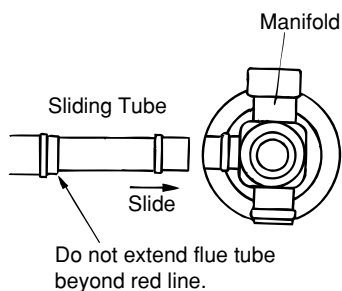

2. Fit the locking clamp over connection between sliding tube and manifold. Engage the hook and rotate it until it snaps against the body of the clamp.

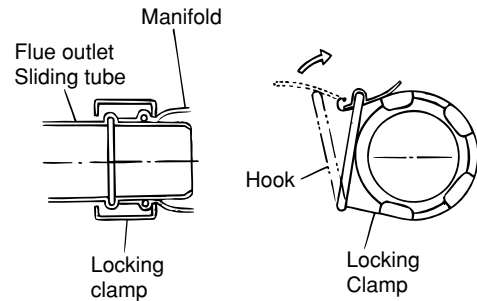

3. Fit the screw clamp between the sliding tube and the flue elbow. Secure with the 4mm screws supplied. The flue outlet is now locked into position.

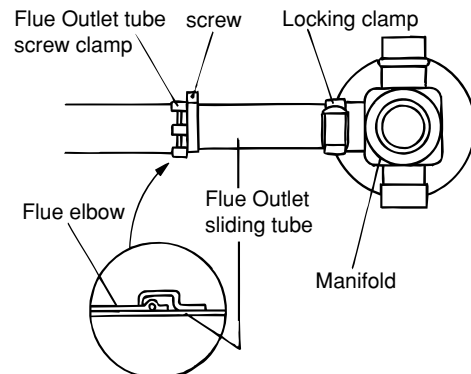

4. Slide the insulation sleeve up to the flue manifold, slip the securing clip over the sleeve as shown.

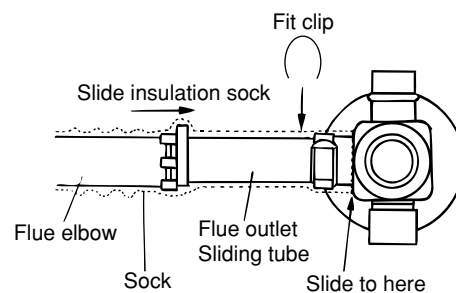

Levelling screws(Adjustable legs)

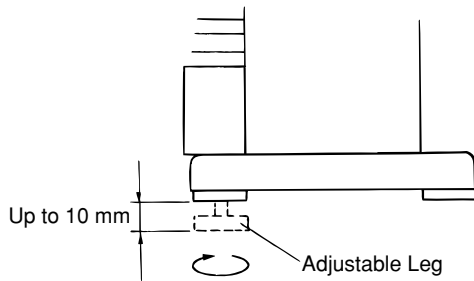

If necessary, the unit can be levelled using the adjustable legs under the front right and left hand side legs.

■ INSTRUCT CUSTOMER ON USE OF HEATER

When you are satisfied that the appliance is operating correctly, explain operation of heater to the customer.

Fault-Failure Procedure

If unable to get the heater to operating correctly, contact Rinnai directly or your Agent or Gas Utility.

Do not use electrical extension cords to connect unit to power supply. Keep the power cord away from the flue.

Some items are not covered under the unit's warranty. Example: annual maintenance, carbon on flame rods/ignitor, dust, spider webs, etc.

OPERATING INSTRUCTION LABEL ENERGYSAVER RHFE-556FA III/FTRA III

FOR YOUR SAFETY READ BEFORE OPERATING

WARNING: If you do not follow these instructions exactly, a fire or explosion may result causing property damage, personal injury or loss of life.

- A. This appliance does not have a pilot. It is equipped with an ignition device which automatically lights the burner. Do not try to light the burner by hand.
- B. BEFORE OPERATING smell all around the appliance area for gas. Be sure to smell next to the floor because some gas is heavier than air and will settle on the floor.
- WHAT TO DO IF YOU SMELL GAS
- Do not try to light any appliance.
 - Do not touch any electric switch; do not use any phone in your building.
 - Immediately call your gas supplier from a neighbor's phone. Follow the gas supplier's instructions.
- If you cannot reach your gas supplier, call the fire department.
- C. Use only your hand push in or turn the gas control knob. Never use tools. If the knob will not push in or turn by hand, don't try to repair it, call a qualified service technician. Force or attempted repair may result in a fire or explosion.
- D. Do not use this appliance if any part has been under water. Immediately call a qualified service technician to inspect the appliance and to replace any part of the control system and any gas control which has been under water.

OPERATING INSTRUCTIONS

- STOP! Read the safety information above on this label.
1. Set the thermostat to lowest setting.
 2. Turn off all electric power to the appliance via the ON/OFF button on the control panel. Locate manual gas valve to be found on back side of heater.
 3. Turn Manual valve clockwise  to the full OFF position.
 4. Wait five (5) minutes to clear out any gas. Then smell for gas, including near the floor. If you then smell gas, STOP! Follow "B" in the safety information above on this label. If you don't smell gas go to next step.
 5. Turn Manual gas valve to the full on position.
 6. Turn on all electric power to the appliance via ON/OFF button.
 7. Set the thermostat to desired setting.
 8. Burner is lit when indicator lamp "ON" turns red.
 9. "ON" indicator flashes when burner fails to ignite.
 10. If the appliance will not operate, follow the instruction "TO turn off gas to appliance" and call your service technician or gas supplier. See manual for additional information.

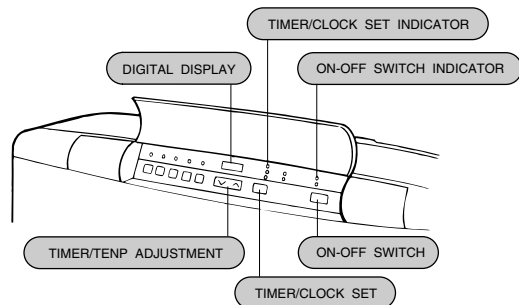
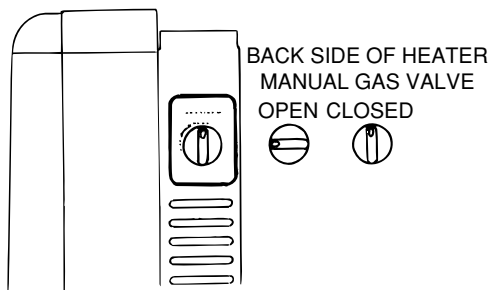

(556FTRA III)

TO TURN OFF GAS TO APPLIANCE

1. Turn off electric power to the appliance using the ON/OFF button located on the control panel.
2. Locate manual valve on back side of unit.
3. Turn manual valve clockwise to the full OFF position.

NOTE: The fan will continue to operate until the appliance is cool, do not turn the appliance off by unplugging it from the wall.

Keep burner and control compartment clean. See installation and operating instructions accompanying heater.

ADDITIONAL CUSTOMER OPERATING INFORMATION

IGNITION

Make certain the heater is connected into both the gas and the electric power.

Depress the ignition ON/OFF button slowly and firmly.

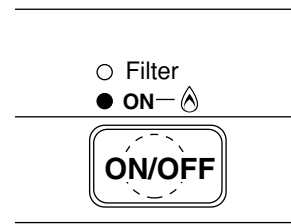

When you release the ignition ON/OFF button the 'Temperature Level' lamps will illuminate, the spark will ignite the main burner and the convection fan will begin to run. If the heater does not ignite within 15 seconds the spark will stop and the 'Temperature Level' lamps will flash. Turn off unit and repeat ignition operation.

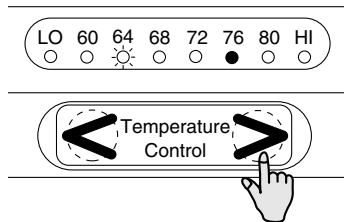

< 556FA III >

TEMPERATURE LEVEL

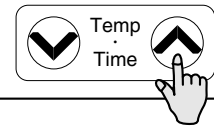
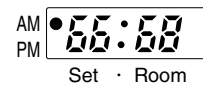

< 556FTRA III >

This heater has an automatic ignition system, when the main burner has lit, the ignition on lamp will glow red, and the spark will stop. There may be a smell of burning dust or oil the first time the heater is lit or when the heater has been out of operation for a long time, this is normal. You may need to repeat the ignition operation the first time the heater is plugged in, due to air in the gas line.

COMBUSTION INDICATOR

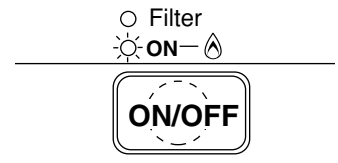

TEMPERATURE CONTROL

The thermostat automatically modulates the burner and the fan to maintain the room temperature which you have selected.

To change the room temperature, simply adjust the temperature control buttons until the desired setting is indicated.

The temperature range from LO to HI is about 54°F (12°C) to 97°F (36°C). Temperature control may be affected by the location of the heater.

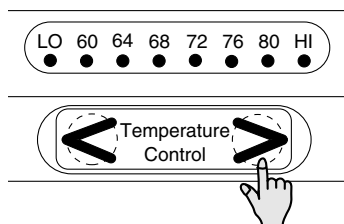

< 556FA III >

TEMPERATURE CONTROL

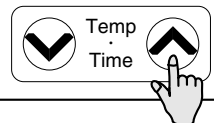
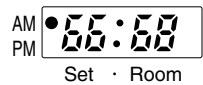

< 556FTRA III >

ROOM TEMPERATURE DISPLAY

Temperature is indicated by the digital read out above the temperature/time adjustment buttons. The room temperature is indicated by the digital display above room. The set temperature is indicated by the digital display above set. You will notice the fan speed changing as the heater modulates to match the room temperature.

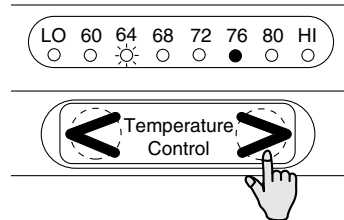

< 556FA III >

TEMPERATURE LEVEL

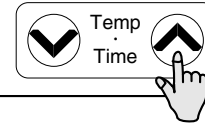
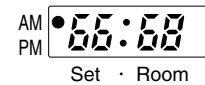

< 556FTRA III >

IGNITION BUTTON

- Filter
- ON — 🔥



TO TURN UNIT OFF

Depress ignition ON/OFF button again. The switch will return to the off position. Do not turn off unplugging at the power outlet. Convection fan continues to run until heater is cool. The convection fan may start again after a few minutes to remove any residual heat.

ECONOMY BUTTON

To select 'Economy Mode', push the 'Economy' button, the green lamp will glow. 30 minutes after the room temperature reaches the preset temperature (set by the thermostat), the 'Economy Mode', if set, reduces the temperature by 2°F, after another 30 minutes it reduces the temperature by a further 2°F, this is an energy saving feature. When the heater is running in lowest position on the thermostat, the 'Economy Mode' does not operate. It does not operate if the heater is under capacity for the room size.

ECONOMY

- Economy



FILTER LAMP

If the filter lamp glows during operation, check air filter for dust. If there is dust present, clean filter. See section on care of heater. Turn heater off before cleaning filters.

- ☀ Filter
- ON — 🔥



OPERATING PRECAUTIONS

Please read this section carefully, before using your Forced flue heater.

Gas Type, Power Source, and Manufactured Date

- Type of gas, power source and manufactured date are displayed on the nameplate placed on the right side of the unit.
 - Do not use gas other than the type of gas (gas group) indicated on the nameplate.
 - This equipment is for 120 V AC (60Hz) only. Do not use power source other than what is listed.

Caution

- Should the type of gas or power source be different, please contact your dealer. Using a different type of gas or power source may affect the performance or may be dangerous.
- If you are moving to another area, please check the types of gas and power source provided in the area. If the types of gas and power source are different, adjustment or modification is necessary. Please consult the gas provider in the new area.

Usage

- Do not use for drying clothes!
 - Do not use for any other purposes other than heating (e.g., drying the laundry).
 - Draping clothes over the unit blocks the warm air outlet or the filter area and is very dangerous, as it causes heat to build up inside the unit.

Usage Location

- Do not use near flammable material !!!

Place the unit sufficiently away from flammable objects such as furniture, wall and curtains. Check carefully when installing the unit.

REQUIRED DISTANCE FROM FLAMMABLES:

Top: At least 250mm or (10") Right: At least 50mm or (2")
Left: At least 50mm or (2")
Front: At least 1m or (40")

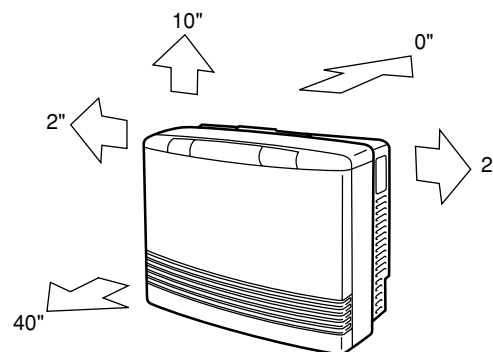

- Watch for falling objects !!!
Do not place under a shelf or in other locations where there is a danger of an object falling on the unit.

- Avoid using in special purpose rooms !!!
This equipment is made for use as a heater for a residential building. Do not use in beauty salons, factories and other places where spray or chemicals are used or where a large amount of dust is present.

Do not use hair treatment products containing silicon in a room heated by the Forced Flue heater, as they may cause ignition error, flame extinction or other malfunctions.

- Insert a board under the unit when placing on carpeted floor !!!
This heater may be installed on combustible flooring. When the heater is installed directly on carpeting, tile or other combustible material other than wood flooring, the heater shall be installed on a metal or wood panel extending the full width and depth of the heater.

Emergency Procedures:

Stay calm and turn the unit off !!!

In case of an emergency (e.g., abnormal overheating of the unit, loud noise), always stay calm, turn the unit off by pushing the ON/OFF button, close the gas valve and contact your dealer or gas supplier.

During a Thunderstorm

When a thunderstorm is approaching, turn the unit off and unplug the power cord. Heavy thunderstorm may cause damage to the unit.

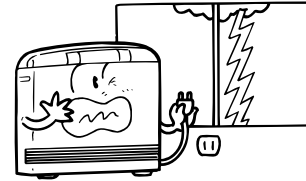

Inspection and Maintenance

- Be sure to perform inspection and maintenance procedures. (See page 30 and 41 for details.) In particular, check the gas connection, power connection and air supply/exhaust pipe connection.
- Do not use the unit if you suspect malfunctioning or damage. Incomplete repairs are dangerous. In case of malfunction contact your dealer or the nearest Rinnai office.

During Snow Accumulation

If the air supply/exhaust vent is covered by snow or damaged by falling icicles, the exhaust may be blocked and cause malfunctioning of the unit. Keep the area around the air supply/exhaust vent free of snow and icicles. Minimum clearance from snow accumulations should be at least (24").

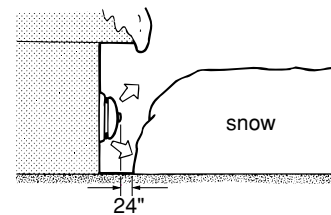

Installation of Unit:

- Please ask your dealer to install the unit properly in a safe location:
- Refer to the installation manual to make sure the unit is installed properly.

Customer's Operating Information

The following pages explain how to use the Forced flue heater.

Also read "Operating Precautions" on pages 26—36.

When Using for the First Time

- Check the power cord and power plug.
 - Firmly plug the unit into an electrical outlet, ensure outlet is properly grounded. An outlet that is not grounded properly can cause unit to operate erratically.
 - Make sure the power cord is not exposed to the heat from the exhaust pipe.
- Fully open the gas valve in the room.

Before the Cold Season Begins

- Check the air supply/exhaust connection.
- Before using this heater, inspect the air supply/exhaust connection to make sure the pipe is not disconnected or bent.
- Check the main unit and the air supply/exhaust.
- Make sure there is no combustible or flammable material near the main unit or the air supply/exhaust.

CAUTION:

If you find a problem with the air supply/exhaust do not use the unit. Contact your dealer or the nearest Rinnai office.

CHILD SAFETY LOCK

The child safety lock feature prevents accidents due to tampering by small children.

- Press the “Child Safety Lock” button.
The “Child Safety Lock” lamp comes on and the lock engages.
- Cancelling the child safety lock.
Press the child safety lock button again and hold for two (1) seconds.

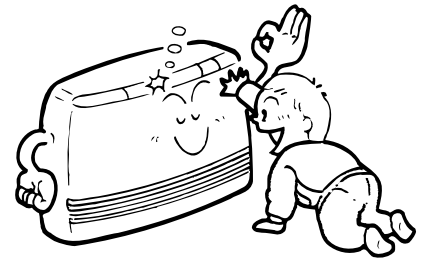

Note:

If the child safety lock is engaged while the unit is operating, all operations by switches and buttons will be disabled except turning the unit off.

If the child safety lock is engaged while the unit is off, all operation will be disabled. When you turn the unit on and the child safety lock is engaged you must cancel the child safety lock before proceeding.

AIR FLOW CONTROL:

- The direction of air flow may be changed to the left or right.
Use a screwdriver or a similar object to change the direction of the vertical louver.

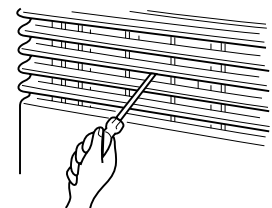
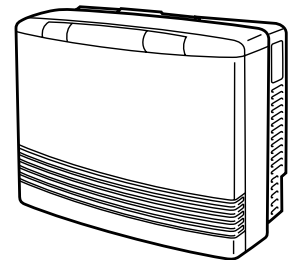

CAUTION:

- Do not adjust repeatedly (more than 5-6 times), as it may cause the louver to break.
- The horizontal louver (which determines the vertical air flow direction) is fixed and cannot be adjusted.
- Do not adjust the air flow direction while warm air is flowing, as it may cause burn injury.

Sensible Temperature Control:

The sensible temperature control feature enables comfortable heating which matches the conditions in the room.

- Based on the information collected by the room temperature thermistor when the heating starts, the heating capacity is automatically adjusted to achieve a comfortable heating effect and to reach the set room temperature quickly.

Adding Water to Humidifier:

If the air gets dry, add water to the humidifier tray to add moisture to the air.

1) Remove the bottom cover.

Hold both ends of the cover and pull toward you to remove the cover.

2) Pull out the humidifier tray and add water.

After adding water, gently push the plate back inside and replace the bottom cover. Be careful not to spill the water, as spilled water may cause staining, corrosion, or damage.

*If the humidifier capacity is not sufficient, use a humidifier available on the market.

*The humidifier tray holds approximately 3 pints (1300cc) of water. The time water lasts varies from 10 to 15 hours, so check the water level occasionally.

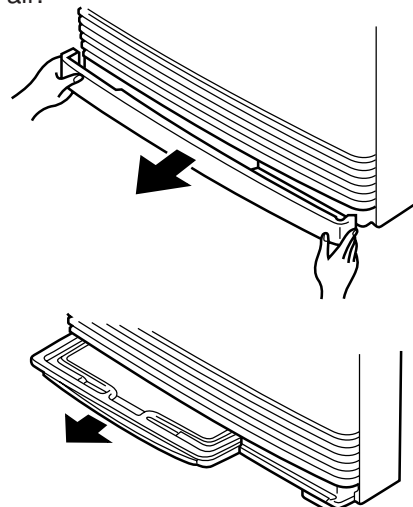

Caution:

- The humidifier tray and the surrounding area are hot when the unit is on. To avoid burns, do not add water to the tray while unit is on.
- Avoid adding water when the room is susceptible to condensation.
- If the water overflows from the water level hole when adding water, do not add any more water.

Care of Unit Exterior:

Dampen soft cloth with warm water, wring water out well and wipe the unit.

Caution:

Never use volatile substances such as benzine or thinners, as they cause fading of paint or deformation of resin.

Care of Air Filter:

Always clean the air filter when the filter indicator lamp starts blinking.

- The filter indicator lamp starts blinking when the dust accumulates on the air filter. In this event, turn the unit off immediately, wait until the unit cools off and clean the filter.
- Even if the lamp is not blinking, if you think the filter is dirty, clean the filter while you are cleaning the room. This will ensure comfortable use.
- The air filter may be removed. Clean both sides of the filter with a vacuum cleaner or a duster.
- If the filter is greasy, wash quickly with detergent, shake water off and dry completely.
- After cleaning and drying, replace the filter securely.

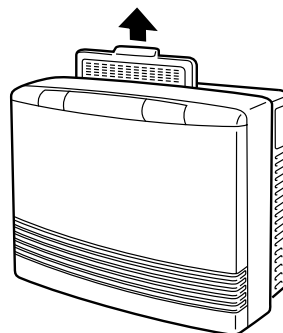
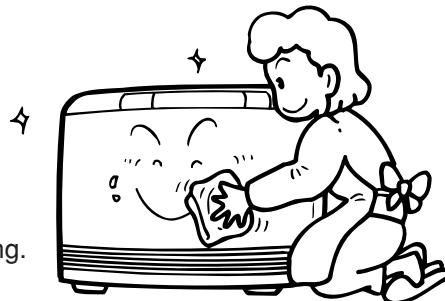

CAUTION:

- If you continue to use the heater with the filter indicator lamp flashing, the sensor may detect trouble and turn the unit off automatically.
- When the unit is turned off automatically, the room temperature display lamp "68"(556FA III) / "14"(556FTRA III) and the "operation/combustion" lamp flashes, indicating that the safety device has been activated. In this event, clean the air filter immediately.

SETTING THE CLOCK

When the appliance is first plugged in and then turned on, the Digital Display will show --:--.
As an example, let's set the clock to 10:35 am.

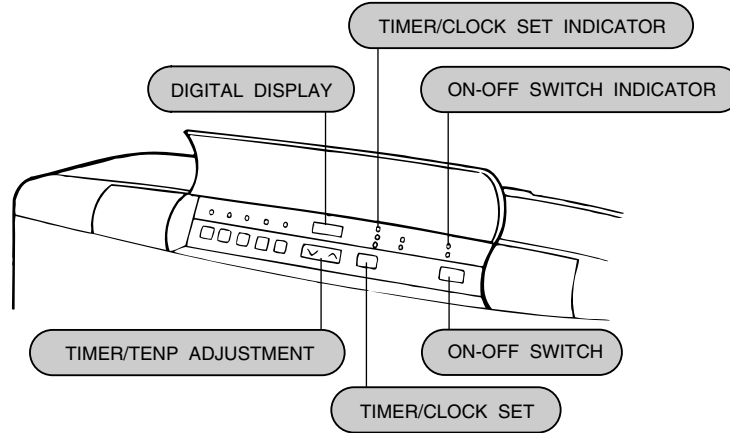

OPEN THE CONTROL PANEL-SEE PAGE 11.

1

When the appliance is first plugged in or after a power failure, the Digital Display will show --:--.
Press the Set Times button once, the Clock Indicator will flash.

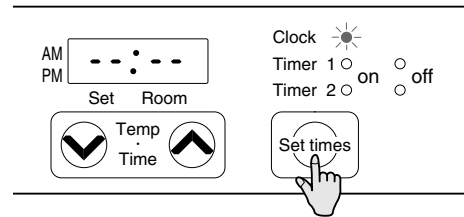

2

Press and hold the “^” button; the minutes will begin to change first, then the time will change by whole hours. Release the button when AM 10:00 shows on the Digital Display. Confirm that you have selected AM, a small indicator on the left hand side of the Digital Display indicates the AM setting.

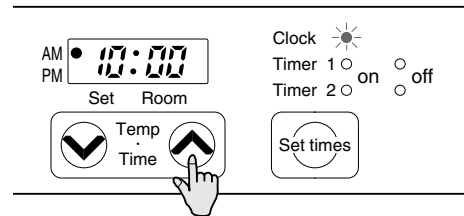

Press and hold the “^” button again, release the button when AM 10:35 shows. If you go past AM 10:35, then the “v” button can be used to change the time settings in reverse.

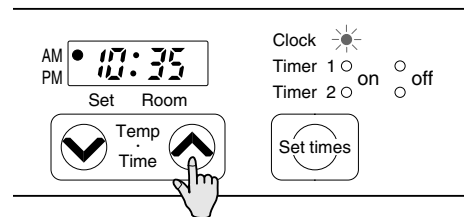

3

Press the Times Set button five times to lock in and complete setting the time. The Clock and Timer indicators will go out. A small indicator on the Digital Display will flash to show that the clock is operating.

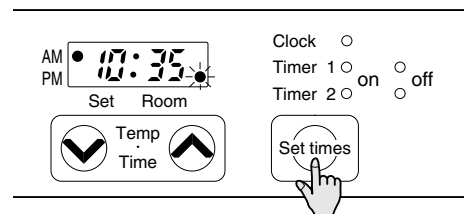

PROGRAMMING THE ON/OFF TIMER(S)

Before programming the Timers you must ensure that the clock has been set to the correct time. See page 32.

As an example, let's program Timer 1 to heat the room by 7:10 AM and finish at 9:00 AM.

1

Press the Set Times button twice. The Digital Display will show AM 6:00. Timer 1 indicator will flash.

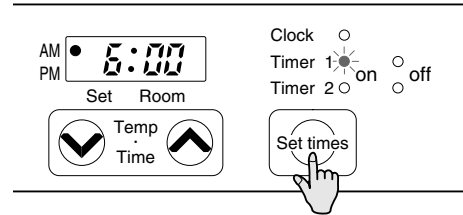

2

Press the “^” button until AM 7:00 appears, release the button, then press it again until AM 7:10 appears. (Press the “v” button if you go past AM 7:10.)

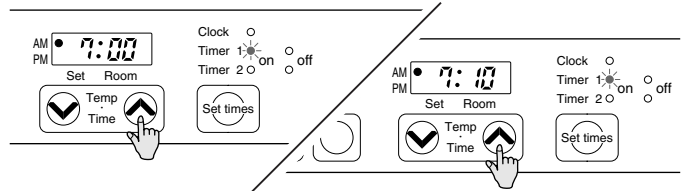

3

Press the Set times button again, the Timer 1 OFF indicator will flash. Press the “^” button until AM 9:00 appears.

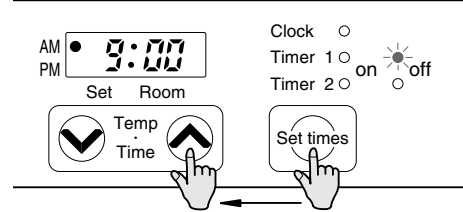

4

Press the Set Times button three times to lock in the programmed time. The Digital Display will show the current time. A small indicator on the Digital Display will flash to show that the Display has returned to the clock.

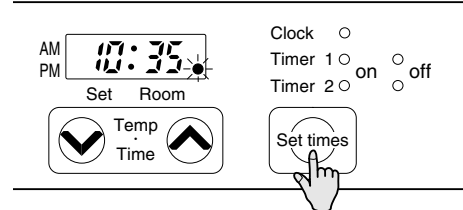

TURN TO NEXT PAGE TO OPERATE THE TIMERS.

TIMER 2 is programmed in the same way, remember to ensure that the Timer 2 indicator is flashing when you program in the desired setting. The Timers can be programmed to operate for any two periods in any 24 hours. Turn to next page to operate the dual timer. The programmed time must be selected and locked-in within one minute of the On Timer indicators flashing otherwise the programmed times will not be retained in the system memory.

OPERATING THE TIMER(S)

Before operating the Timer(s), the clock time must be correct, and a starting time and finishing time for the Timer(s) must be programmed. See pages 32 and 33. The two Timers operate in the same way. This heater does not commence operation at the programmed starting time. It will attempt to heat a room by the programmed starting time. See pre-heat page 35, for further explanation.

1

To select the Timer(s) to commence heating:
Check the time shown on the Digital Display is correct. See page 32. Check the ON and OFF times, for both Timers if necessary, see page 33.

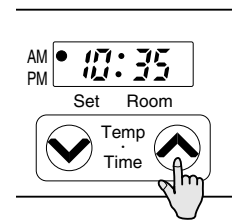

2

Press the ON-OFF button to operate the heater.
The On indicator will glow green and the heater will begin to operate. Select the desired temperature setting.

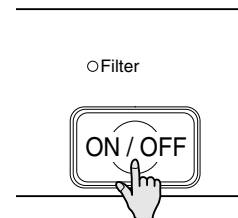

3

Press the Timer 1 and/or Timer 2 button(s).
The Timer indicator(s) will glow and the heater will remain on standby until one hour prior to the time programmed into the selected Timer(s) is reached. When this time is reached, the Timer indicator will flash and the heater will operate.
The ON indicator glows red when the heater commences operation.

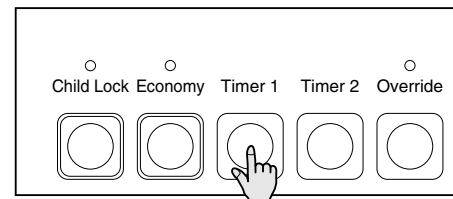

SET AND FORGET OPERATION

Your heater can be operated to alternate between Timers automatically during cold weather by selecting Timer 1 and Timer 2 together. Both Timer indicators will glow. The appliance will remain on standby at intervals between the programmed finishing and starting time of each Timer. While the heater is operating during programmed intervals the Timer indicator will flash.

If there is a power failure, the system memory will retain the Timer programs, and the clock will stop at the time the power goes off. The clock will start again when the power comes back on, but the time will be slow by the duration of the power failure. To set the clock to the correct time after the power has come back on, simply follow the instructions on page 32.

PRE-HEAT

1

This function operates automatically in conjunction with either of the Timers. When a Timer is selected, the heater may operate anywhere within an hour prior to the programmed starting time of the Timer.

The Pre-heat function will heat a room to the pre-set temperature by the programmed On Time.

This function is called Pre-heat due to the way it operates. The room temperature is sensed one hour before reaching the programmed time of either Timer.

The temperature differential at the time of sensing the room temperature, combined with the data from the previous operation governs exactly how long before the programmed On time the micro computer will operate the heater and ignite the burner.

The following chart may help to improve understanding of the Pre-heat function.

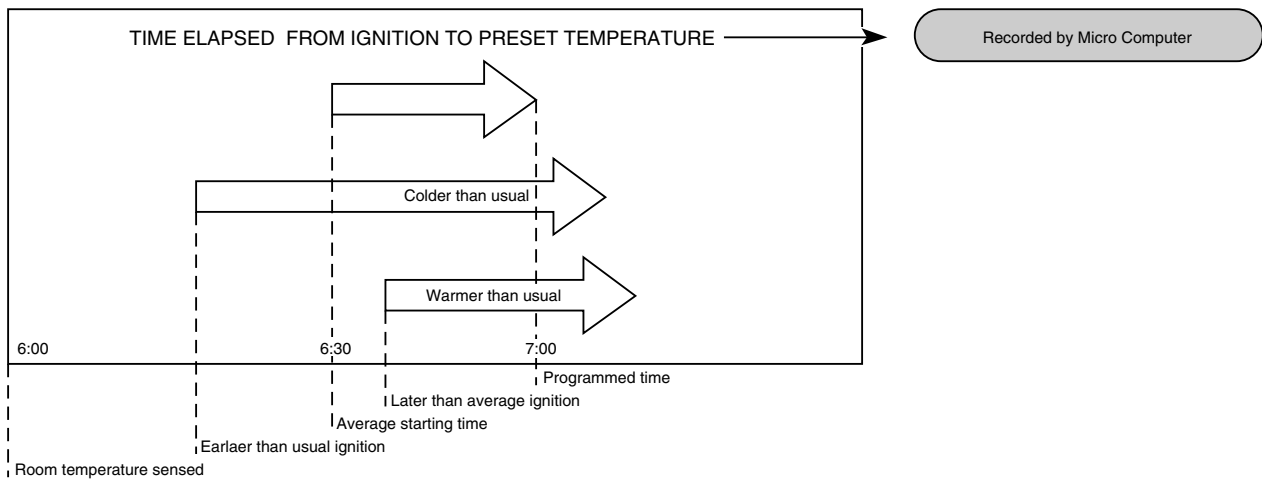

OVERRIDE FUNCTION

This function is intended to be used to manually override the current operation of the heater, For example; if the heater is in standby mode (i.e. between finishing time and starting time of a Timer), and the Override button is selected, then the heater will begin to operate, and heat the room.

1

To operate the Override simply press the Override button. The Override indicator will flash.

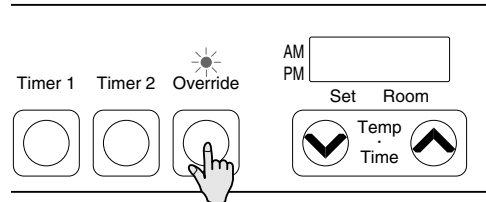

2

To manually deactivate the Override simply press the Override button again. The Override indicator will go out, and the heater will return to standby mode.

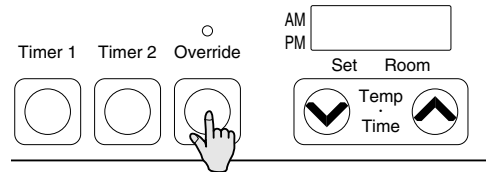

The heater will continue to operate on Override until the Override button is pressed again, or one of the Timers takes over the operation of the appliance. This means that the Override mode will automatically drop out if a programmed Starting time is reached. The appliance will then return to operating at times programmed into the Timer(s).

USING THE REMOTE CONTROL

To Turn ON or OFF

Remote Control will not turn heater ON if Timer(s) have been selected.

To manually operate when Timer(s) are not selected, simply press the ON or OFF button.

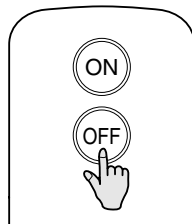

To Change Temperature

To alter the temperature at any time while the heater is operating, simply press the "▲" or "▼" buttons.

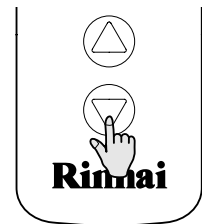

If the Timer(s) have been selected, and the heater is in standby mode, and the OFF button on the Remote Control is pressed, the Timer(s) will be deactivated.

TESTING

Testing Unit

Purge air from gas line.
Refer to pipe sizing chart if in doubt about the size of the gas line.
Connection can easily be reached from the top, rear of the unit. Check for leaks, using soapy water after turning gas on.

Plug unit in and turn power on, (CAUTION - 120V inside unit).

Turn thermostat to "HI", turn control to "ON". Unit should ignite within 10 seconds.

(If unit does not ignite first time it will spark again after 10 seconds). If unit still does not ignite, there may be air in the gas line, turn control "OFF" then "ON" again.

Check pressure, regulator is factory set, if pressure is incorrect, check supply before altering regulator.

Turn control to "OFF" position, remove pressure manometer and replace test point screw.

Re-light unit, on "HI" setting. Slide thermostat control slowly towards the "LO" position, the heater will cut down, then cut out.

(Depending on the room temperature).

Turn the power off. Replace the casing.

Turn power on.

Re-check operation.

WARNING: DO NOT OPERATE UNIT UNTIL PROPER INSTALLATION HAS BEEN COMPLETED.

CHECK

Fault-Failure Procedure

If unable to get the unit to operate correctly, contact Rinnai Agent, or Gas Utility. Please read the fault finding charts before reporting faults.

Do not use this heater if any part has been under water. Immediately call a qualified service technician to inspect the heater and to replace any part of the control system and any gas control which has been under water.

"WARNING" Do not operate appliance with the panel(s) removed, cracked or broken.

Installation and repair should be done by a qualified service person. The appliance should be inspected before use and at least annually by a qualified service person.

More frequent cleaning may be required due to excessive lint from carpeting, bedding material, etc.. It is imperative that control compartments, burners and circulating air passageways of the appliance be kept clean. Ventilating system should be inspected and cleaned annually.

Rinnai's service assistance telephone number is 1/800/621—9419.

PRE-SERVICE CHECK

Before asking for a service call please check the following points.
These points are part of the normal operation of the unit.

■ At Ignition:

Heater does not operate.



Is the heater plugged in?
Have the fuses or breaker blown at the switch board?
Is there a power failure?
Is the air filter blocked?
Is anything blocking the outlet for the hot air?
Is the flue blocked?
Are timers set? Clear timers and operate again.

Warm air does not flow when the burner lights.



The fan is started automatically after a short delay.
This is to allow the heat exchanger to warm up, helping to avoid cold draughts.

Smoke or strange smells are produced on the first trial light up after installation.



This is caused by grease or oil and dust on the heat exchanger and will stop after a short time.

Sharp clicking noises at ignition, or when unit cuts down on the thermostat, or goes out.



This is simply expansion noise from the heat exchanger.

■ During Combustion:

Clunking noise when the thermostat operates.



This is the sound of the solenoid gas valves opening and closing.

Unit is not heating room.



Is the air filter blocked?
Is the set temperature high enough?
Is the warm air outlet blocked by anything?
Are the doors and windows of the room closed?

Air filter is blocked or the louvers are blocked or obstructed.



Allow heater to cool, clean air filter, operate again.

Heater will not re-ignite after overheating.



Even after unit has cooled down the heater does not ignite again. Repair is necessary.
Contact your local agent or Rinnai for a Service call.

■ When the unit is turned off.

Convection fan continues to run after turning OFF.



This is to remove the residual heat from the heat exchanger, the fan will stop when the heater cools down.

■ Other Points:

Steam is discharged from the flue terminal.



High efficiency appliances tend to discharge water vapor on cold days, this is normal.

Unit cuts off without apparent reason.



Check whether filters are blocked, dirty filters will cause the heater of overheat.

Power Failure.



Switch OFF, then ON again when power is restored to re-set controls.

Remote control does not operate



Check battery. Try moving closer to heater.

TROUBLE SHOOTING

Your RHFE-556FA III/FTRA III requires very little maintenance, simply clean the rear fan filter as needed and wipe the outer case and louver section with a damp cloth.

| Cause | Problem | | | | | | | | Remedy |
|---|-----------------|-----------------------|--------------------|-----------------------------------|--------------|----------------|---------------------------------|-----------------------------|--|
| | No ON indicator | Burner doesn't ignite | Unusual combustion | Combustion stops during operation | Smell of gas | Noisy ignition | Takes too long to warm the room | Remote Control doesn't work | |
| Not Plugged In | ● | ● | | | | | | | Plug In |
| Power Cut | ● | ● | | ● | | | | | Re-ignite manually after power is restored |
| (Initial Installation) Air In Gas Pipe | | ● | | | | | | | Purge air (Installer) |
| Gas Filter Blocked | | ● | ● | | | | ● | | Service Call |
| Miss Ignition | ● | ● | | | | | | | Service Call |
| Flue terminal obstructed | | | ● | ● | | ● | | | Clear obstruction |
| Flue manifold not connected | | | | | | ● | | | Service Call |
| Louver obstructed | | | | ● | | | ● | | Clear obstruction |
| Air filter blocked | | | | ● | | | ● | | Clean filter |
| Gas Escape | | | | | ● | | | | Service Call |
| Child Proof Lock Set | | ● | | | | | | | Cancel Child Proof Lock |
| Gas turned off at meter | ● | ● | | | | | | | Turn gas on |
| Check battery (remote control) | | | | | | | | ● | Replace battery |
| On Timer is set | | ● | | | | | | | Cancel on timer |

General maintenance items are not covered under unit's warranty. Such as cleaning dust, debris and carbon from flame rod, and improper set up of unit.

ERROR MESSAGES

The Energysaver 556 has the ability to check its own operation continuously. If a fault occurs, an Error Message will flash on the Digital Display of the control panel. This assists with diagnosing the fault, and may enable you to overcome a problem without a service call. Please quote the code displayed when enquiring about service.

| CODE DISPLAYED | | FAULT | REMEDY |
|------------------------|-------------|---------------------------------------|--|
| 556FA III | 556FTRA III | | |
| 60 | 11 | Ignition failure | Check gas is turned ON. Service call if repeated. |
| LO | 12 | Flame failure | Check gas is turned ON. Service call if repeated. |
| 68 | 14 | Overheat | Clean filter Service call if repeated. |
| HI | 16 | Room overheat | Lower room temperature to less than 40°C(104°F). |
| 72 · 76 | 31 | Room Temperature Sensor faulty | Service call. |
| 76 · 80 | 32 | | |
| 64 · 68 · 72 | 33 | Overheat Temperature Sensor faulty | Service call. |
| 68 · 72 · 76 | 34 | | |
| LO · 60 · 64 | 53 | Sparker failure | Service call. |
| 60 · 64 · 68 | 61 | Combustion fan failure | Service call. |
| 64 · 68 | 70 | Faulty ON/OFF switch | Service call. |
| LO · 60 | 71 | Faulty solenoids | Service call. |
| 80 | 72 | Faulty Flame Rod | Service call. |
| 72 · 76 · 80 · HI | 73 | Communication Error | Turn heater OFF, then ON again. |
| 60 · 64 · 68 · 72 · 76 | 99 | Flue blok | Check around flue terminal |

In all cases, you may be able to clear the Error Message simply by turning the heater OFF, then ON again. If the Error Message still remains or returns on the next operation, contact Rinnai or your nearest service agent and arrange for a service call.

MAINTENANCE / SERVICE

MAINTENANCE SUGGESTIONS

This heater has been designed and constructed for a long performance life when installed and operated properly under normal conditions. Regular inspections, as outlined in this section, are strongly recommended as means of keeping your heater operating efficiently throughout the season.

1. Cleaning

Heater must be cleaned annually. Keep heater clear of dust and debris especially in and around burner.

Cleaning procedures of heater are as follows:

- 1) Turn heater off. Allow to cool for one hour.
- 2) Remove the Front Panel by removing screws. See parts breakdown on panels.
- 3) Use pressurized air to remove dust from around main burner.
- 4) Use soft dry cloth to wipe cabinet.

DO NOT DAMAGE OR DISTORT ANY PARTS OF HEATER.

DO NOT USE WET CLOTH OR SPRAY CLEANERS ON BURNER.

2. Visual check of main burner flames.

Flame pattern should be as shown in the following Figures.

The burner must flame evenly over the entire surface when operating correctly. The flame must burn with a clear blue stable flame. See parts breakdown of burner for location of view ports. Any and all parts removed for inspection or service must be replaced before operating unit.

3. The appliance area must be kept clear and free from combustible materials, gasoline and other flammable vapors and liquids.
4. The flow of combustion and ventilation air should not be obstructed.
5. Verify proper operation after servicing.

VISUAL CHECK

SATISFACTORY

FRONT VIEW

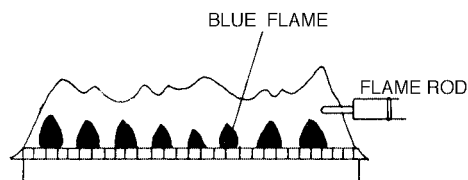

UNSATISFACTORY

FRONT VIEW

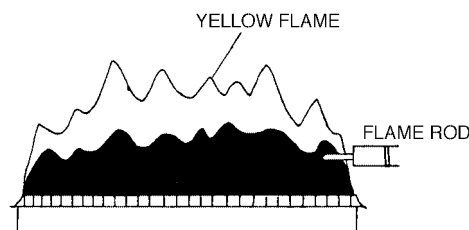

- VENT MAINTENANCE
- VENT SYSTEM
Must be checked annually for blockage or deterioration. See vent installation instructions.
- MAINTENANCE-ELECTRIC MOTORS
Motors are permanently lubricated and need no lubrication. Keep fan and motor free of dust and dirt clean annually.

WIRING DIAGRAM

| CODE | COLOR |
|------|--------------|
| bk | black |
| bl | blue |
| br | brown |
| gr | green |
| gr/y | green/yellow |
| pl | purple |
| r | red |
| w | white |
| y | yellow |
| gy | grey |
| or | orange |

| MARK | PART NAME |
|------|---------------------------|
| MS | MAIN SWITCH |
| TH | THERMISTOR |
| TF | THERMAL FUSE |
| F | FUSE |
| ER | ELECTRODE |
| POV | MODULATING SOLENOID VALVE |
| TR | TRANSFORMER |
| FR | FLAME ROD |

| MARK | PART NAME |
|----------|---------------------------|
| OH, TH | OVER HEAT THERMISTOR |
| OHS1 ~ 3 | OVER HEAT SWITCH |
| FM | CONVECTION FAN MOTOR |
| SP | SPARKER |
| SV1 ~ 2 | MAIN SOLENOID VALVE 1 ~ 2 |
| BL | COMBUSTION FAN MOTOR |
| RCR | REMOTE CONTROL RECEIVER |
| TB | TERMINAL BLOCK |

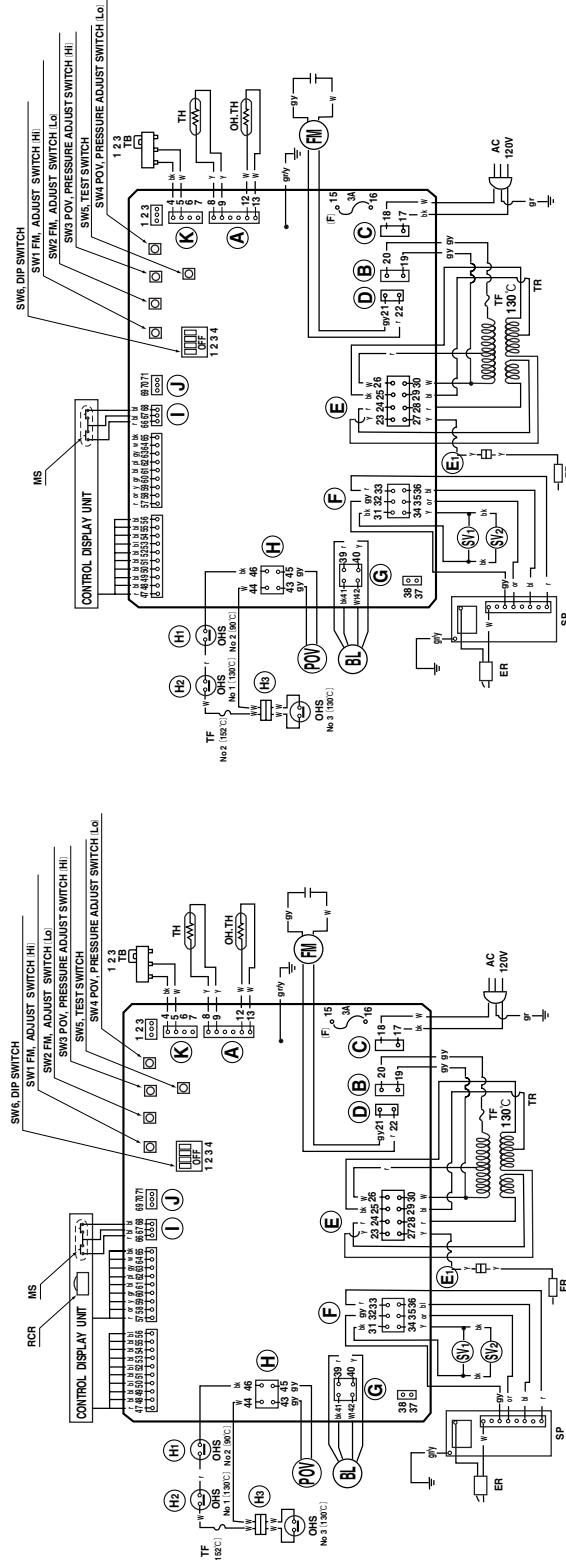

< 556FTRA III >

< 556FA III >

If any of the original wire as supplied with the appliance must be replaced, it must be replaced with a wire of a least a 194°F temperature rating and number 18AWG or its equivalent.

“CAUTION: Label all wires prior to disconnection when servicing controls. Wiring errors can cause improper and dangerous operation.”
Verify operation after servicing

CONSUMER SUPPORT

Warranty Information

The installer is responsible for your heater's correct installation.

Please complete the information below to keep for your records:

Purchased from: _____

Address: _____ Phone: _____

Date of Purchase: _____

Model No.: _____

Serial No.: _____

Installed by: _____ Installer's License No.: _____

Address: _____ Phone: _____

Date of Installation: _____

Limited Warranty

Gas Direct Vent Wall Furnace

What is covered?

This Warranty covers any defects in materials or workmanship, subject to the terms stated below. This Warranty extends to the original purchaser and subsequent transferees, but only while the product remains at the site of the original installation. This Warranty only extends through the first installation of the product and terminates if the product is moved or reinstalled at a new location.

How long does coverage last?

| Item | Period of Coverage |
|------------------|----------------------------------|
| Heat Exchanger | 10 years from date of purchase * |
| All Other Parts | 5 years from date of purchase |
| Reasonable Labor | 2 years from date of purchase |

Limited Warranty - continued

What will Rinnai do?

Rinnai will repair any part or component that is defective in materials or workmanship as set forth as follows. All repair parts must be genuine Rinnai parts. All repairs or replacements must be performed by an individual or servicing company that has been authorized by Rinnai. Rinnai will pay reasonable labor charges associated with the repair or replacement of any part or component.

Replacement of the product may be authorized by Rinnai only. Rinnai does not authorize any person or company to assume for it any obligation or liability in connection with the replacement of a product. If Rinnai determines that repair of a product is not possible, Rinnai will replace the product with a comparable product, at Rinnai's discretion.

* If the Heat Exchanger fails due to a defect in material or workmanship within the sixth (6) through the tenth (10) year from the date of purchase, Rinnai will make the following allowances toward the purchase of a replacement Heat Exchanger:

| Heat Exchanger | |
|------------------------|------------------|
| Year of Failure | Allowance |
| 6 | 50% |
| 7 | 40% |
| 8 | 30% |
| 9 | 20% |
| 10 | 10% |

How do I get service?

You must contact a qualified/authorized service provider for the repair of a product under this Warranty. For the name of a qualified/authorized service provider please contact your place of purchase, visit the Rinnai website (www.rinnai.us), call Rinnai at 1-800-621-9419 or write to Rinnai at 103 International Drive, Peachtree City, Georgia 30269.

Proof of purchase is required to obtain warranty service. You may show proof of purchase with a dated sales receipt, or by registering within 30 days of purchasing the product. To register your appliance, please visit www.rinnairegistration.com. For those without internet access, please call 1-866-RINNAI1 (746-6241). Receipt of Registration by Rinnai will constitute proof-of-purchase for this product. However, Registration is not necessary in order to validate this Warranty.

What is not covered?

This Warranty does not cover any failures or operating difficulties due to accident, abuse, misuse, alteration, misapplication, force majeure, improper installation, improper conversion*, improper maintenance or service, or for any other causes other than defects in materials or workmanship. This Warranty does not apply to any product whose serial number or manufacture date has been defaced.

* Improper conversion includes conversions for inventory adjustment.

Rinnai is not liable for any special, incidental, indirect or consequential damages that may arise, including damage to person or property, loss of use, or inconvenience. Some states do not allow the exclusion or limitation of incidental or consequential damages, so the above limitation may not apply to you.

Limitation on implied warranties

Any implied warranties of merchantability and fitness arising under state law are limited in duration to the period of coverage provided by this limited Warranty, unless the period provided by state law is less. Some states do not allow limitations on how long an implied Warranty lasts, so the above limitation may not apply to you.

This Warranty gives you specific legal rights, and you may also have other rights which vary from state to state.

SCHEMATIC DIAGRAM

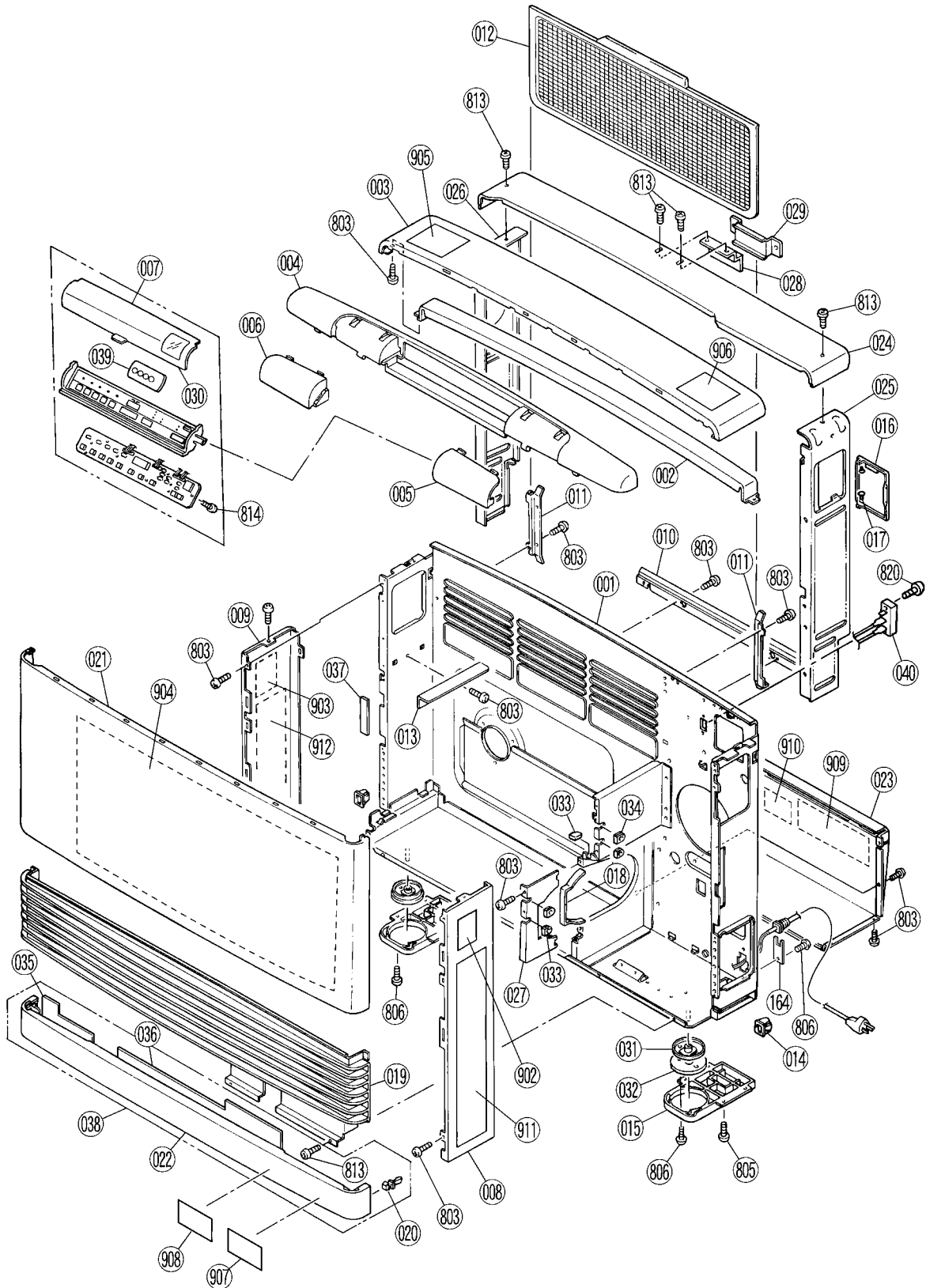

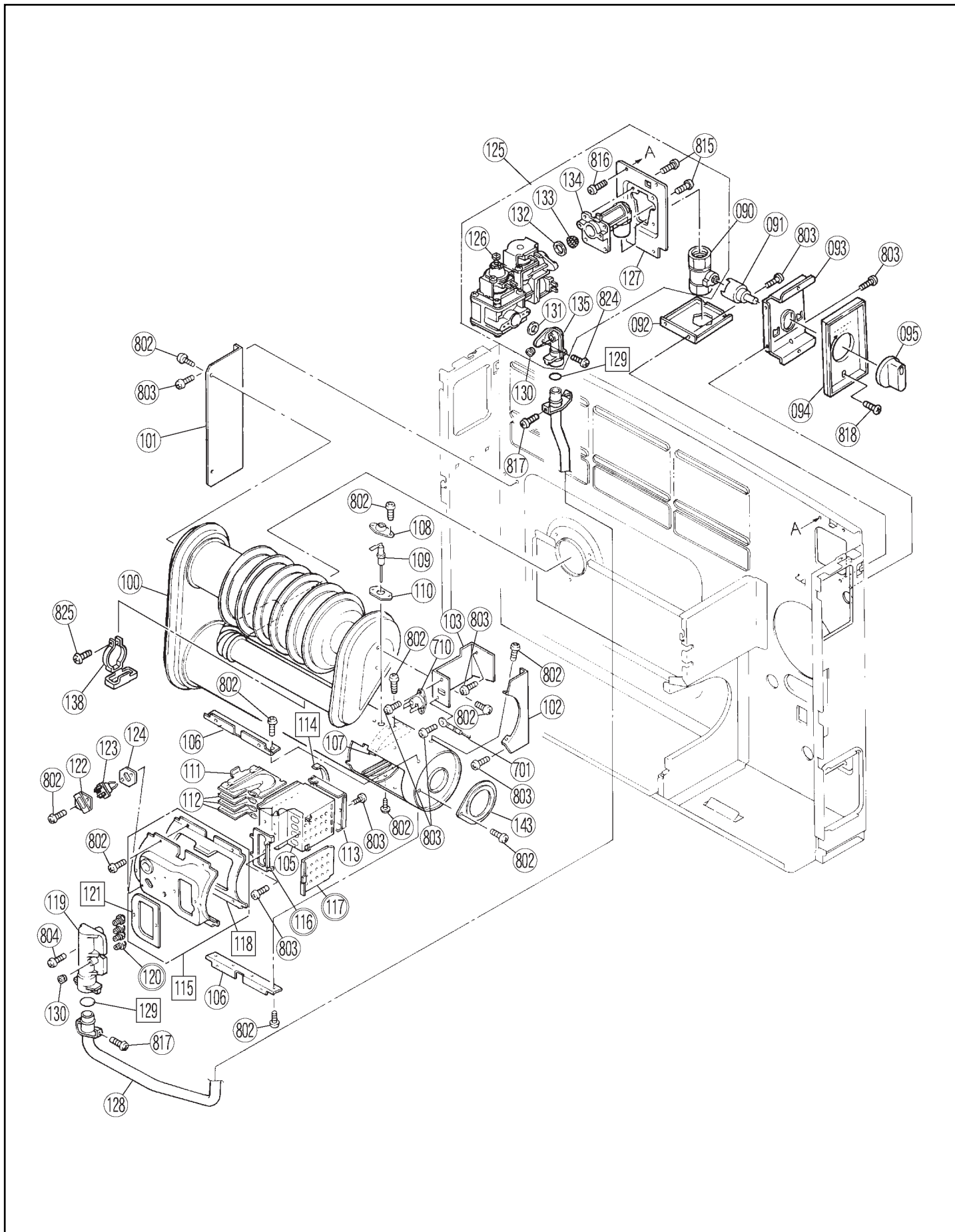

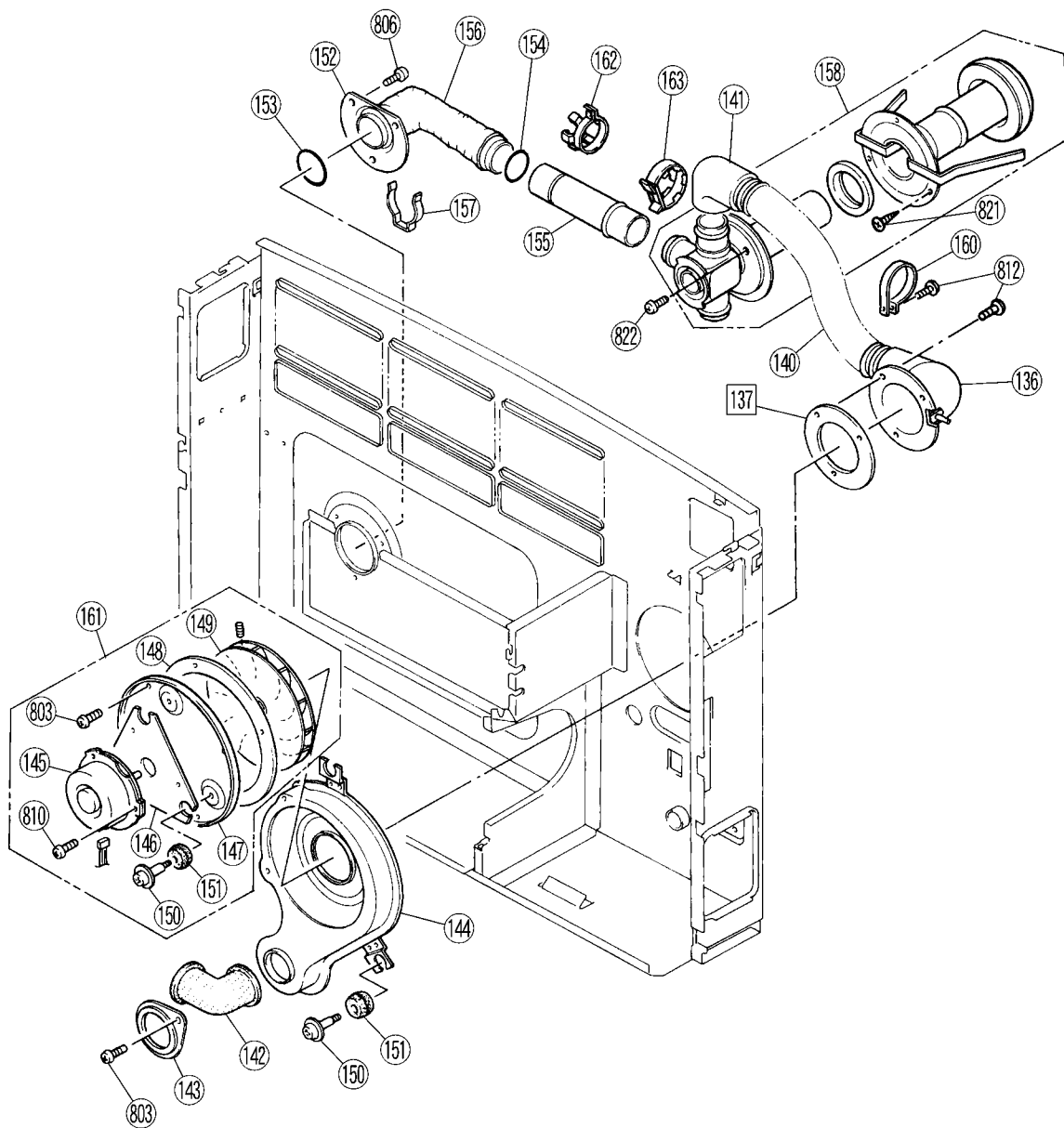

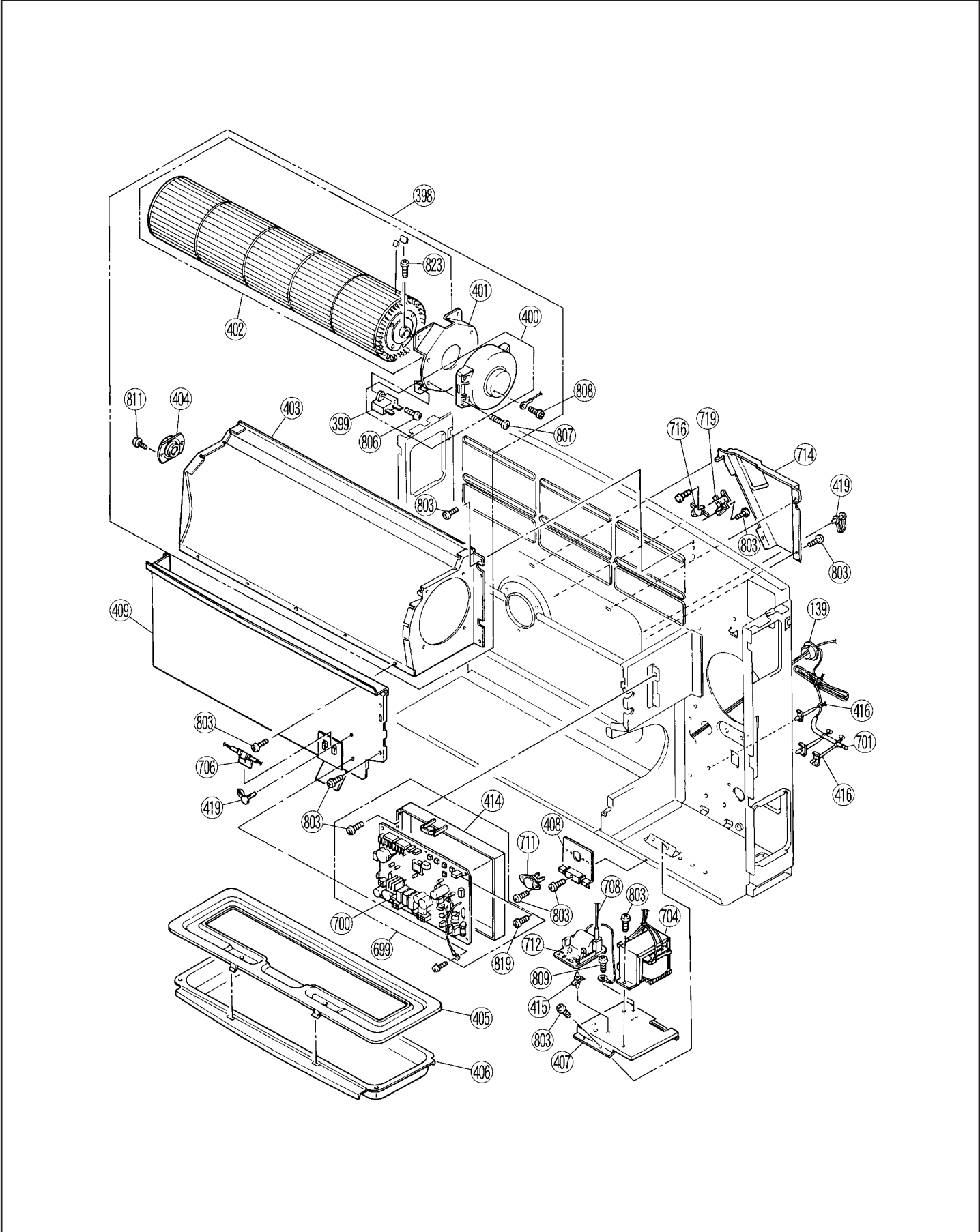

PARTS LIST

| No. | PART NAME | PART No. 556FAⅢ | QTY | PART No. 556FTRAⅢ | REMARKS |
|-----|----------------------------|--------------------|-----|----------------------|---------|
| 001 | REAR PANEL ASS'Y | 556F-311-4 | 1 | | |
| 002 | TOP PLATE SUPPORTER | 556F-480 | 1 | | |
| 003 | TOP PLATE | 556F-469-2 | 1 | | |
| 004 | DECORATING FRONT PANEL | 556F-467-2 | 1 | | |
| 005 | DECORATING FRONT PANEL(R) | 556F-475-2 | 1 | | |
| 006 | DECORATING FRONT PANEL(L) | 556F-476B-4 | 1 | 556F-476B-5 | |
| 007 | CONTROL P.C.B ASS'Y | 431F-1600 | (1) | 556F-2020 | |
| 008 | SIDE PANEL(R) | 556F-456-2-B | 1 | | |
| 009 | SIDE PANEL(L) | 556F-456-1-B | 1 | | |
| 010 | AIR FILTER SUPPORTER | 556F-312 | 1 | | |
| 011 | AIR FILTER SUPPORTER(SIDE) | 556F-313 | 2 | | |
| 012 | AIR FILTER ASS'Y | 556F-462-2 | 1 | | |
| 013 | SUPPORT BOARD TO FAN | 556F-314 | 1 | | |
| 014 | LATCH | CP-90380 | 2 | | |
| 015 | LEG | 556F-464 | 2 | | |
| 016 | CONTROL LID | 431F-1320-1 | 1 | | |
| 017 | NYLON RIVET | 550F-0418 | 2 | | |
| 018 | HEAT EXCHANGER PACKING | 554F-421-2 | 1 | | |
| 019 | LOUVER ASSY | 556F-472-2 | 1 | | |
| 020 | STRIKE | CP-90379 | 2 | | |
| 021 | FRONT PANEL | 556F-470-3 | 1 | | |
| 022 | UNDER COVER ASS'Y | 556F-473-2 | 1 | | |
| 023 | HEAT SHIELD PANEL | 556F-321 | 1 | | |
| 024 | BACK SPACER TOP | 556F-457-3 | 1 | | |
| 025 | BACK SPACER(R) | 431F-1310 | 1 | | |
| 026 | BACK SPACER(L) | 431F-1330-1 | 1 | | |
| 027 | WARM AIR SEAL PANEL | 556F-305 | 1 | | |
| 028 | WALL BRACKET | 304F-9077 | 1 | | |
| 029 | SPACER BRACKET | RHF300-152 | 1 | | |
| 030 | OPERATION BOX LID | 556F-471 | 1 | 556F-1018 | |
| 031 | LEG FIXING BOARD | 550F-0220 | 2 | | |
| 032 | RUBBER LEG | 550F-0225 | 2 | | |
| 033 | CORD PACKING B | AU131-236-b | 3 | | |
| 034 | CORD PACKING A | AU131-236-a | 2 | | |
| 035 | HEAT INSULATOR A | 556F-477 | 1 | | |
| 036 | HEAT INSULATOR B | 556F-478 | 1 | | |
| 037 | REAR PANEL PACKING | 556F-325 | 1 | | |

Note : If no part number is listed for the 556FTRAⅢ this means it uses the same part as the 556FAⅢ.

| No. | PART NAME | PART No. 556FA III | QTY | PART No. 556FTRA III | REMARKS |
|--------|------------------------------|---|-----|-------------------------|-----------|
| 038 | UNDER COVER TOTAL ASSY | 556F-479-2 | 1 | | |
| 039 | REMOTE CONTROLLER | | | 556F-2005 | |
| 040 | TERMINAL BLOCK | 431F-1481 | 1 | | |
| | | | | | |
| 090 | MANUAL VALVE | 1001F-1633 | 1 | | |
| 091 | KNOB ADAPTOR | 431F-1080 | 1 | | |
| 092 | VALVE REINFORCEMENT BOARD | 431F-1050 | 1 | | |
| 093 | PANEL FITTING PLATE | 431F-1040 | 1 | | |
| 094 | VALVE PANEL | 431F-1030 | 1 | | |
| 095 | VALVE KNOB | CP-40369-24 | 1 | | |
| | | | | | |
| | | | | | |
| 100 | HEAT EXCHANGER SET ALL ASS'Y | 556F-2040-SP | 1 | | |
| 101 | FIXING PLATE | 556F-214 | 1 | | |
| 102 | COMBUSTION CHAMBER FIXER | 556F-215 | 1 | | |
| 103 | OHS FIXER | 556F-216 | 1 | | |
| 105 | BURNER BOX ASSY | 431F-1094 | 1 | | |
| 106 | FLANGE B | 556F-131-2 | 2 | | |
| 107 | SEAL PLATE | 556F-2032 | 2 | | |
| 108 | ELECTRODE PLATE | RHF250-038 | 1 | | |
| 109 | FLAME ROD | 1001F-104-4 | 1 | | |
| 110 | FLAME ROD PACKING | 554F-148 | 1 | | |
| 111 | BURNER ASSY C | 431F-1091-2 | (1) | | NG, LPG |
| 112 | BURNER ASSY | B3A2-4 | (3) | | NG, LPG |
| 113 | BURNER SUPPORTER ASS'Y | 556F-225 | 1 | | |
| 114 | BURNER BOX PACKING | 556F-211 | 1 | | |
| 115 | BURNER BOX FITTING PLATE SET | 556F-224-SP | 1 | | |
| 116(1) | DAMPER | 556F-209-15 | 1 | | LPG |
| 116(2) | DAMPER | 556F-209-7 | 1 | | NG |
| 117(1) | SECONDARY AIR DAMPER | 556F-208-5 | 1 | | LPG |
| 117(2) | SECONDARY AIR DAMPER | 556F-208-7 | 1 | | NG |
| 118 | PACKING C | 556F-2047 | 1 | | |
| 119 | MANIFOLD | 556F-202-2 | 1 | | |
| 120 | INJECTOR | AU129-210 ⁰⁸⁵ _{-1,13} | 4 | | LPG NG |
| 121 | MANIFOLD PACKING | 556F-203 | 1 | | |
| 122 | ELECTRODE MOUNTING PLATE | 554F-114 | 1 | | |
| 123 | ELECTRODE | 556F-510 | 1 | | |
| 124 | ELECTRODE PACKING | 554F-147 | 1 | | |
| 125(1) | GAS CONTROL TOTAL ASS'Y A | PC-111-2-A | 1 | | LPG |
| 125(2) | // C | PC-111-2-C | 1 | | NG |

Note : If no part number is listed for the 556FTRA III this means it uses the same part as the 556FA III.

| No. | PART NAME | PART No. 556FA III | QTY | PART No. 556FTRA III | REMARKS |
|-----|-----------------------------|-----------------------|-----|-------------------------|---------|
| 126 | GAS CONTROL ASS'Y | C36D-36-S | 1 | | |
| 127 | INLET REINFORCEMENT BOARD | 431F-1060 | 1 | | |
| 128 | INTER CONNECTION ASSY | 431F-1150 | 1 | | |
| 129 | O RING | M10B-1-14 | 2 | | |
| 130 | BRIND SCREW | AU39-965 | 2 | | |
| 131 | PACKING | M10B-13-14 | 1 | | |
| 132 | PACKING | C3I1-7 | 1 | | |
| 133 | GAS FILTER | RCK-6808 | 1 | | |
| 134 | GAS INLET | 431F-1110 | 1 | | |
| 135 | OUTLET D | 554F-220-4 | 1 | | |
| 136 | AIR INLET | 553F-340-3 | 1 | | |
| 137 | AIR INLET PACKING | RHF300F-79 | 1 | | |
| 138 | DRAIN PAN ASS'Y | 556F-154 | 1 | | |
| 139 | BUSHING | CP-90326 | 1 | | |
| 140 | FLEXIBLE HOSE | RHF300-51-10 | 1 | | |
| 141 | AIR INLET ELBOW | RHF300-52 | 1 | | |
| 142 | CONNECTING TUBE | 556F-404 | 1 | | |
| 143 | CONNECTING TUBE FIXER | 556F-408 | 2 | | |
| 144 | COMBUSTION FAN CASING ASS'Y | 556F-414-1 | 1 | | |
| 145 | COMBUSTION FAN MOTOR | 308F-419 | 1 | | |
| 146 | MOTOR MOUNTING PANEL | 554F-601 | 1 | | |
| 147 | LID | 554F-604 | 1 | | |
| 148 | LID PACKING | 554F-618 | 1 | | |
| 149 | COMBUSTION FAN | 554F-608 | 1 | | |
| 150 | SCREW FOR MOTOR | CP-30310 | 6 | | |
| 151 | CUSHION RUBBER | 308F-8273 | 6 | | |
| 152 | FLUE SLIDING TUBE ASS'Y | 302F-1102 | 1 | | |
| 153 | O RING E | RHF300-200-e | 1 | | |
| 154 | O RING D | FOT-001-016-3 | 1 | | |
| 155 | SLIDING TUBE | RHF250-148-2 | 1 | | |
| 156 | COVER | 302F-1103 | 1 | | |
| 157 | RING | 302F-1206 | 1 | | |
| 158 | VENT ASS'Y | 431F-1900 | 1 | | |
| | | | | | |
| 160 | CLAMP | CP-90378 | 2 | | |
| 161 | COMBUSTION FAN TOTAL ASS'Y | 431F-1200 | 1 | | |
| 162 | PIPE STOPPER F | 305F-0013 | 1 | | |
| 163 | PIPE STOPPER C | 305F-0017 | 1 | | |
| 164 | POWER SUPPLY CABLE BRACKET | RC-329-1033 | 1 | | BLACK |
| | | | | | |

Note : If no part number is listed for the 556FTRA III this means it uses the same part as the 556FA III.

| No. | PART NAME | PART No. 556FA III | QTY | PART No. 556FTRA III | REMARKS |
|-----|----------------------------|-----------------------|-----|-------------------------|-------------|
| 398 | CONVECTION FAN TOTAL ASS'Y | 431F-1500 | 1 | | |
| 399 | CONDENSOR | 431F-1260-2 | 1 | | 2.6 μ F |
| 400 | CONVECTION MOTOR | 431F-1260 | 1 | | |
| 401 | MOTOR BASE | 556F-256 | 1 | | |
| 402 | CONVECTION FAN | 556F-258 | 1 | | |
| 403 | FAN CASING ASSY | 556F-257-2 | 1 | | |
| 404 | BEARING | RC-223-74 | 1 | | |
| 405 | HUMIDIFIER TRAY LID | 556F-310 | 1 | | |
| 406 | HUMIDIFIER TRAY | 556F-309 | 1 | | |
| 407 | IGNITER FIXER | 556F-412 | 1 | | |
| 408 | OHS FITTING PLATE | 556F-522 | 1 | | |
| 409 | HEAT SHIELD BOARD ASSY | 556F-322 | 1 | | |
| | | | | | |
| 414 | P.C.B FITTING PLATE | 556F-407 | 1 | | |
| 415 | CIRCUIT BOARD SPACER | CP-90436-3 | 4 | | |
| 416 | CABLE CLIP | CP-90125-2 | 3 | | |
| | | | | | |
| 418 | WIRE CLIP | CP-90107-2 | 3 | | |
| 419 | CLAMP | CP-90077-3 | 5 | | |
| | | | | | |
| | | | | | |
| 699 | P.C BOARD TOTAL ASSY | 431F-1470-3 | 1 | | |
| 700 | P.C BOARD | ED-223 | 1 | | |
| 701 | THERMISTOR | 556F-1021 | 1 | | |
| | | | | | |
| 703 | POWER SUPPLY CORD | CP-90466-2 | 1 | | |
| 704 | TRANSFORMER | ET-184 | 1 | | |
| 705 | MV HARNESS | 431F-1400 | 1 | | |
| 706 | WIRE HARNESS | 431F-1410 | 1 | | |
| | | | | | |
| 708 | HIGH TENSION CORD | 431F-1460 | 1 | | |
| | | | | | |
| 710 | OVERHEAT SWITCH | ES-01171 | 1 | | 266° F OFF |
| 711 | OVERHEAT SWITCH | ES-01170 | 1 | | 194° F OFF |
| | | | | | |
| 712 | IGNITER | EI-161 | 1 | | |
| 713 | SLEEVE | 3022-0344 | 1 | | |
| | | | | | |
| | | | | | |

Note : If no part number is listed for the 556FTRA III this means it uses the same part as the 556FA III.

| No. | PART NAME | PART No. 556FA III | QTY | PART No. 556FTRA III | REMARKS |
|-----|----------------------------|--------------------------------------|--------|--|------------|
| 714 | TF COVER | 556F-524 | 1 | | |
| 715 | FR LEAD | 431F-1430 | 1 | | |
| 716 | OVERHEAT SWITCH | ES-01174 | 1 | | 266° F OFF |
| 717 | EARTH LEAD | 550F-0818 | 2 | | |
| 719 | OHS3 BRACKET | 556F-570 | 1 | | |
| 720 | OHS3 LEAD | 556F-571 | 1 | | |
| 721 | MOTOR LEAD | 431F-1220 | 1 | | |
| 801 | SCREW | ZAA0420SZ | | | |
| 802 | SCREW | ZEAB0408UK | | | |
| 803 | SCREW | ZEAB0408SZ | | | |
| 804 | SCREW | ZEDB0412SZ | | | |
| 805 | SCREW | ZEAB0410SZ | | | |
| 806 | SCREW | ZEDB0408SZ | | | |
| 807 | SCREW | ZEDB0416SZ | | | |
| 808 | SCREW | ZHAE0306SZ | | | |
| 809 | SCREW | CP-30421-1 | | | |
| 810 | SCREW | ZDAA0410SZ | | | |
| 811 | SCREW | ZEAB0406SZ | | | |
| 812 | SCREW | ZEDB0410SZ | | | |
| 813 | SCREW | ZEAB0408SC | | | |
| 814 | SCREW | ZDAA2.608SN | | | |
| 815 | SCREW | ZAA0422SZ | | | |
| 816 | SCREW | ZBA0410SZ | | | |
| 817 | SCREW | ZHAA0406SZ | | | |
| 818 | SCREW | ZEDB0408SC | | | |
| 819 | SCREW | CP-30486-2 | | | |
| 820 | SCREW | ZEAB0414SZ | | | |
| 821 | SCREW | CP-30408 | | | |
| 822 | SCREW | ZBB0410SC | | | |
| 823 | SCREW | ZAA0408SZ | | | |
| 824 | SCREW | ZHAA0410SZ | | | |
| 900 | CONVERSION KIT FOR L.P.G | 556F-2004-3 | 1 | | |
| 901 | CONVERSION KIT FOR N.G. | // -2 | 1 | | |
| 902 | RATING PLATE | CP-74167 ⁻⁵ ₋₆ | 1 | CP-72135 ⁻¹³ ₋₁₄ | LPG NG |
| 903 | RATING PLATE | CP-74168 ⁻⁵ ₋₆ | 1 | CP-72151 ⁻¹³ ₋₁₄ | LPG NG |
| 904 | OPERATION LABL | 431F-1810 | 1 | 556F-2011 | |
| 905 | FILTEL LABEL | 1001F-1651 | 1 | | |
| 906 | CAUTION LABEL | 431F-1830 | 1 | | |
| 907 | CAUTION LABEL D | 1001F-1652 | 1 | | |
| 908 | CAUTION LABEL | 1001F-1656 | 1 | | |
| 909 | STICKER | 431F-1840 431F-1841 | 1 1 | | LPG NG |
| 910 | CAUTION LABEL | 1001F-1654 | 1 | | |
| 911 | RATING PLATE SUPPORT LABEL | CP-74253 ⁻¹ ₋₂ | 1 | | |
| 912 | RATING PLATE SUPPORT LABEL | CP-74254 ⁻¹ ₋₂ | 1 | | |

Note : If no part number is listed for the 556FTRA III this means it uses the same part as the 556FA III.

FLOW DIAGRAM

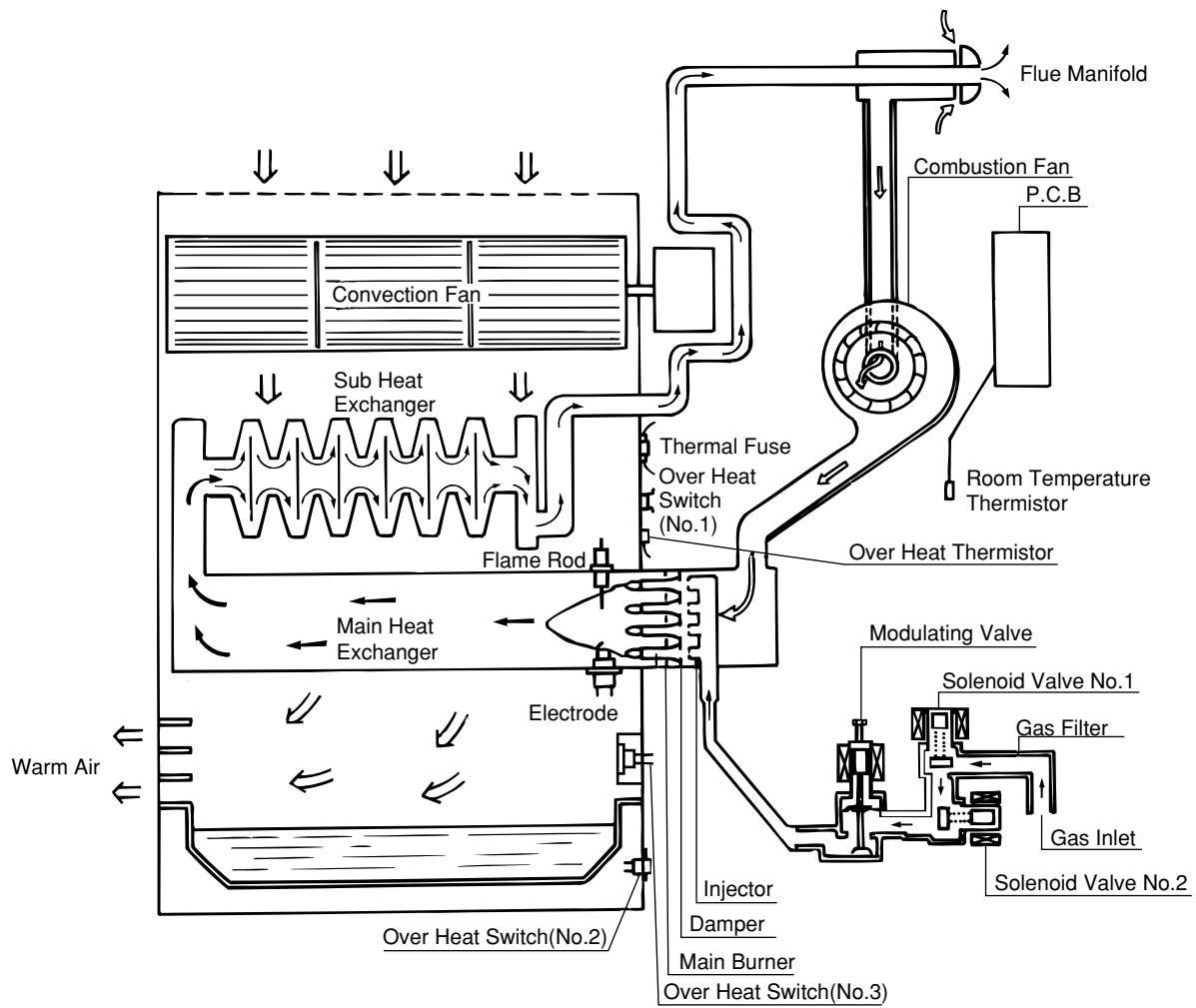

Vent sizes:

5 Vent lengths are available. inch (mm)

- S Vent suits walls 3"~4 1/2" (75~115)
- A Vent suits walls 4 1/2"~9 1/2" (115~240)
- B Vent suits walls 9 1/2"~15 3/4" (240~400)
- C Vent suits walls 15 3/4"~23 5/8" (400~600)
- D Vent suits walls 23 5/8"~31 1/2" (600~800)

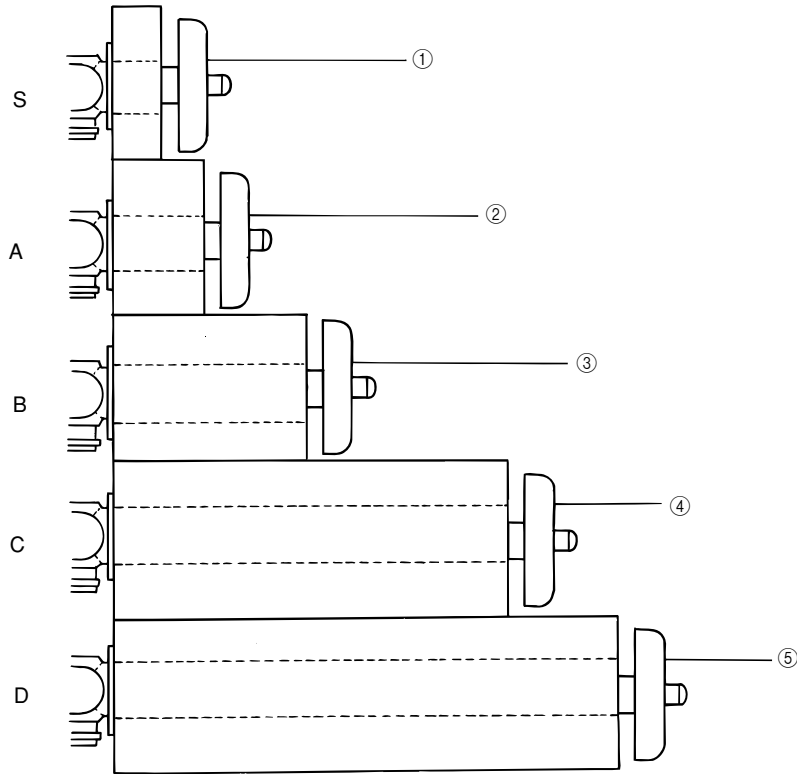

| NO. | RANK | PARTS NAME | PARTS NO. | QTY | REMARKS |
|-----|------|--------------|-----------|-----|--------------|
| 1 | M | VENT KIT - S | FOT-150 | 1 | |
| 2 | M | VENT KIT - A | FOT-151 | 1 | |
| 3 | M | VENT KIT - B | FOT-152 | 1 | |
| 4 | M | VENT KIT - C | FOT-153 | 1 | |
| 5 | M | VENT KIT - D | FOT-154 | 1 | |
| 6 | | RUBBER SEAL | | 1 | SEE PAGE 14. |
| | | | | | |
| | | | | | |
| | | | | | |

EXTENSION SET PARTS AND INSTALLATION GUIDE

| | | |
|---------|-----------|----------------|
| FOT-155 | 20"(0.5m) | EXTENSION SET |
| FOT-156 | 40"(1m) | EXTENSION SET |
| FOT-157 | 80"(2m) | EXTENSION SET |
| FOT-158 | | BENT ELBOW SET |

Rinnai

- This extension set is to be used for installations requiring extra distance.
MAXIMUM VENT LENGTH 13' WITH 2 ELBOWS

■ NAMES AND NUMBERS OF PARTS

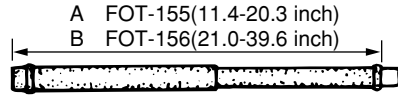

① EXHAUST PIPE



④ BENT ELBOW



⑦ PIPE STOPPER B



⑩ NUT



② EXHAUST PIPE(STRAIGHT) 40 inch



⑤ HOSE JOINT



⑧ PIPE CLAMP



⑪ SCREW A

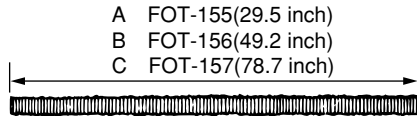

③ AIR INTAKE HOSE



⑥ PIPE STOPPER A



⑨ WALL-FIXTURE



⑫ SCREW B

| | | FOT-155 | FOT-156 | FOT-157 | FOT-158 |
|---|---|------------------------|---------|---------|---------|
| ① | A | EXHAUST PIPE | 1 | | |
| | B | EXHAUST PIPE | | 1 | 1 |
| ② | | EXHAUST PIPE(STRAIGHT) | | 1 | |
| ③ | A | AIR INTAKE HOSE | 1 | | |
| | B | AIR INTAKE HOSE | | 1 | |
| | C | AIR INTAKE HOSE | | | 1 |
| ④ | | BENT ELBOW | | | 1 |
| ⑤ | | HOSE JOINT | 1 | 1 | 1 |
| ⑥ | | PIPE STOPPER A | 1 | 1 | 2 |
| ⑦ | | PIPE STOPPER B | 1 | 1 | 1 |
| ⑧ | | PIPE CLAMP | 2 SET | 3 SET | 4 SET |
| ⑨ | | WALL FIXTURE | 2 | 3 | 4 |
| ⑩ | | NUT | 2 | 3 | 4 |
| ⑪ | | SCREW A | 2 | 3 | 4 |
| ⑫ | | SCREW B | 4 | 6 | 8 |

- ※ When the appliance is installed using a vent extension that exceeds 6 feet you must change the jumper on the vent extension terminal block as shown.

Terminal is located at the rear of unit next to gas inlet.

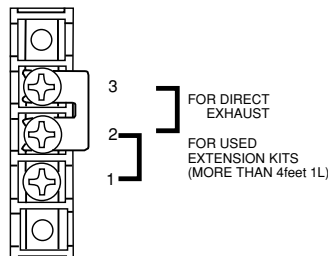

■ TYPES COMPATIBLE WITH EXTENSION SET

RHFE-431FA III/556FA III/FTRA III INSTALLING AN EXTENSION KIT

Installing an extension kit requires construction of an air line and the exhaust line. The air line is connected between the Air Supply Elbow at the rear of the heater and the air inlet port on the Flue pipe. Similarly, the exhaust line is connected between the joint pipe at the rear of the heater, and the exhaust port on the Flue pipe.

Caution: Check to see there is no debris in pipe or hose.

■ HOW TO INSTALL

MODEL: RHFE-431FA III/556FA III/FTRA III

Example: Using 2 sets of extension set and 1 bent set.

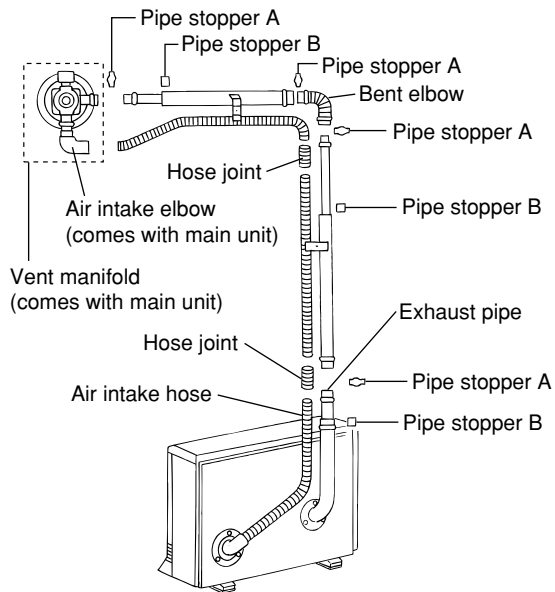

Example: Using 80 inches slide pipe set.

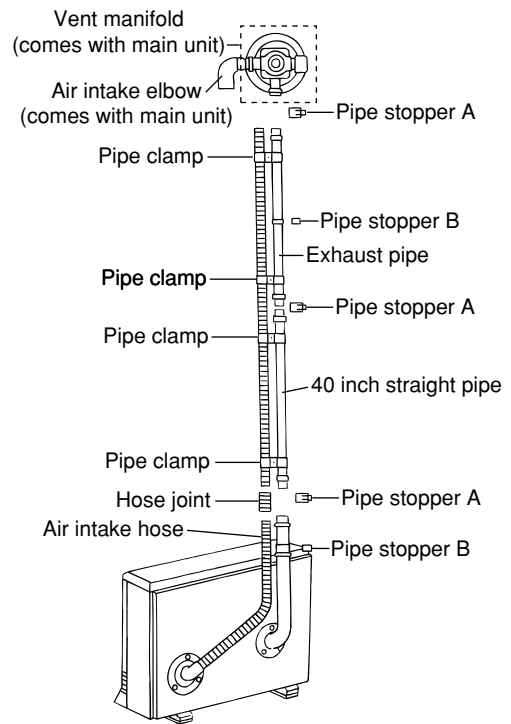

1. How to connect exhaust pipes

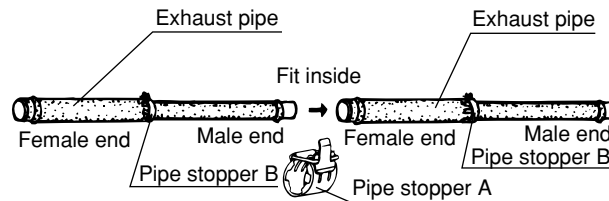

To connect the exhaust pipes, fit the male end into the female end and clamp with pipe stopper A to prevent slipping. The exhaust pipe can be telescoped to the required length; do not cut it.

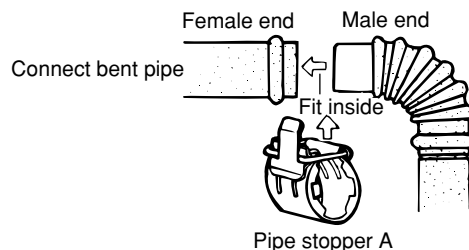

2. How to connect air intake hose

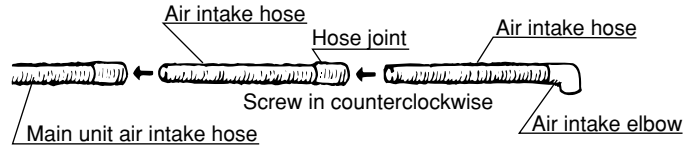

Screw hose joint half of its length onto the air intake hose, then screw another air intake hose into the joint. The hose can be cut to the required length.

IMPORTANT: The PVC air line is longer than the exhaust line and may need to be cut to size. Be sure, however, to thoroughly deburr all rough edges.

3. Affixing the air intake hose and exhaust pipe

NOTE: Maintain 1" clearance between exhaust pipe and combustible materials (0" clearance between exhaust pipe and non-combustible materials).

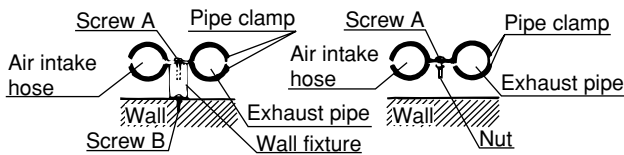

- Set the air intake hose and exhaust pipe into the pipe clamps, screw the clamp onto the wall fixture, and affix to the wall with screw B.
- The air intake hose and exhaust pipe can also be screwed onto the wall using the pipe clamp and the nut.

CAUTIONS

1. Maximum extendable length

FOR BEST ROOM AIR HUMIDITY, KEEP WATER IN THE HUMIDIFIER TRAY.

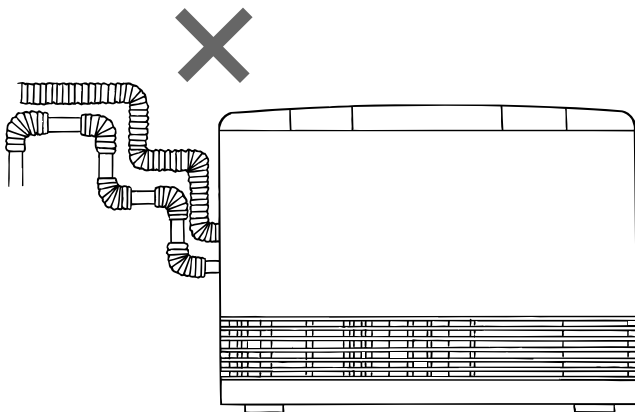

- 13 feet, 2 bends
- The bend where the hose and pipes leave the body is not counted.
- The air intake hose should run along the exhaust pipe.

4. How to use the bent pipe

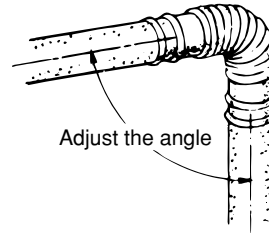

With the exhaust pipes inserted into the ends, bend the bent pipe to the angle required for installation. This part is mainly used for curves and for connection to vent terminal.

2. To prevent water condensation

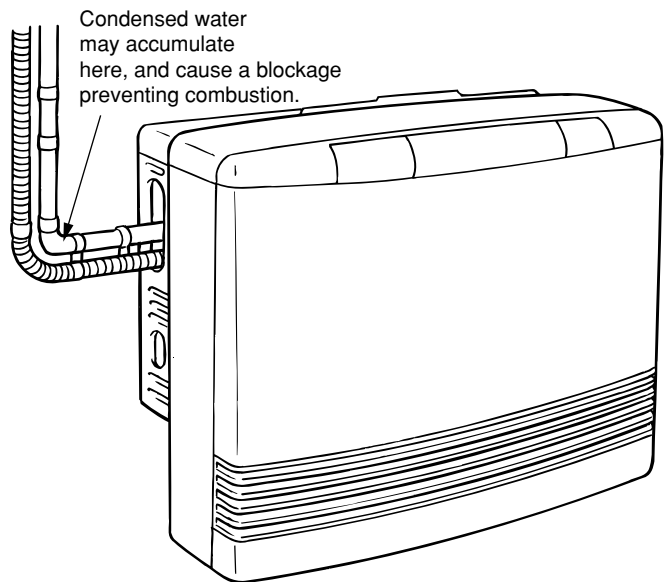

CAUTION

Never allow the exhaust pipe to sag, as condensed water may accumulate and cause incomplete combustion.

3. Condensed water formed by combustion, will run back to the unit, and may overflow from the condensation pan if pipes are longer than 8 feet. Therefore, pipes exceeding these lengths should be made to drain to the outside by giving their horizontal portions 3° or more downward and outward slope.

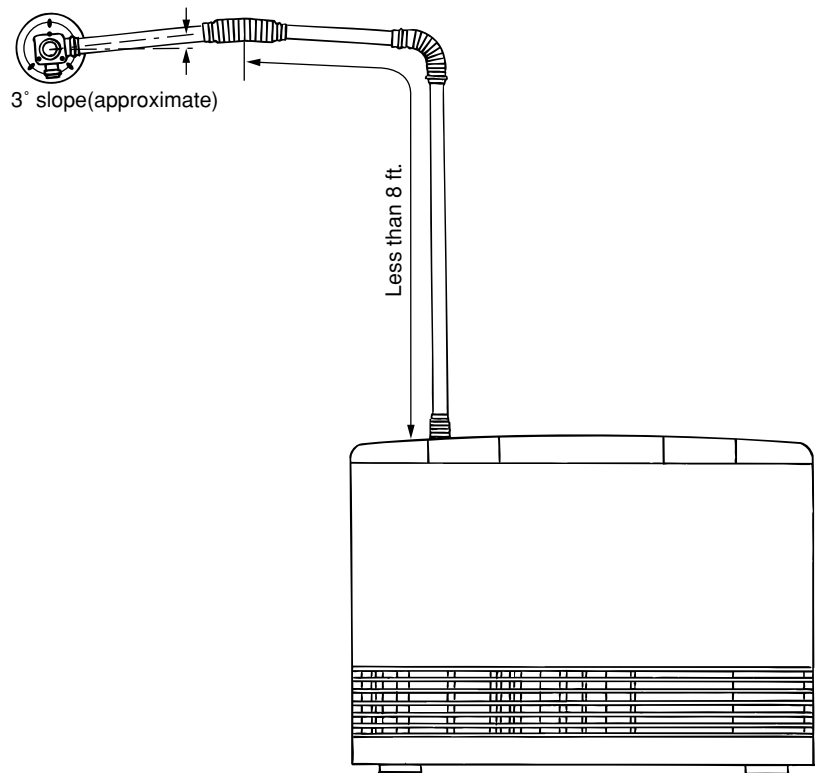

4. Wherever the air intake hose and exhaust pipe run sideways, try to have the exhaust pipe on top (to prevent the air intake hose from sagging onto the exhaust pipe).

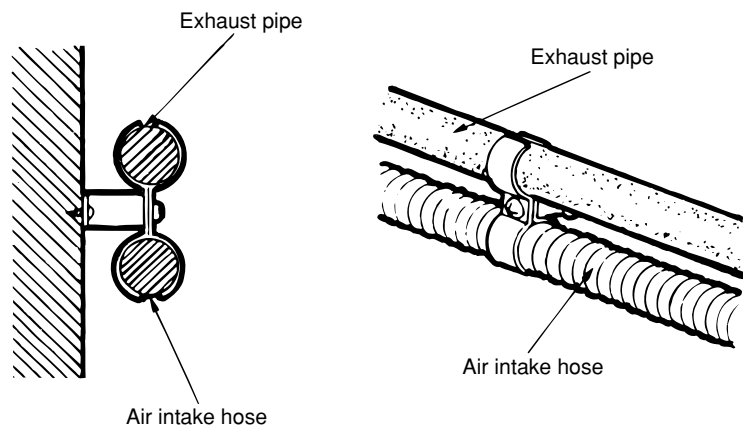

QUALIFIED INSTALLING AGENCY

The installation must conform to local codes, in the absence of local codes, the installation must conform with American National Standard (National Fuel Gas Code) known as NFPA 54 and ANSI Z223.1.1992.

Available from the American National Standards Institute, Inc., 1430 Broadway, New York, N.Y. 10018 or from the National Fire Protection Association, 470 Atlantic Avenue, Boston, Mass. 02210.

Ask about **Rinnai**

Rinnai's other fine products

Rinnai America Corporation
103 International Drive
Peachtree City, GA 30269
TOLL FREE: 1-800-621-9419
FAX: 678-829-1666
www.rinnai.us



Tankless Water Heaters

- Residential and Commercial Applications
- Continuous Hot Water
- Up to 9.8 GPM
- High Energy Efficiency
- Propane or Natural Gas
- Internal or External Installation
- Digital Temperature Control
- Small, Compact Design



Direct Vent Furnaces

- High Efficiency
- Cool-to-the-touch Cabinet
- Blower Included
- Vent Terminal A Included
- 556 and 1004 Models Available in Beige, White and Silver
- Gas Conversion Kit Included



Direct-Vent Fireplace, RHFE-750ETR

- Up to 83% AFUE Energy Efficiency
- Zero-Clearance Installation
- Available in Four Options of Fronts
- Remotes and Fan Included
- Gas Conversion Kit Available



Hydronic Air Handler

- Designed for Use with Rinnai Systems
- Domestic Hot Water Priority
- Optional Programmable Thermostat
- Zero Clearance to Combustibles
- Accommodates Standard Cased-Coils

Register your product at www.rinnaregistration.com
or call 1-866-RINNAI1 (746-6241)

Rinnai

AMERICA CORPORATION

103 International Drive,

Peachtree City, Georgia 30269

Phone:1-800-621-9419

Fax:1-888-474-6624

www.rinnai.us

Register your product at www.rinnairegistration.com or
call 1-866-RINNAI1 (746-6241)

556F-2009 × 15(00)

Printed in Japan 2008.09



108936