

PRO-FORM[®]

Club Design 1000

Model No. PFEL09907.0

Serial No. _____

Write the serial number in the space above for reference.

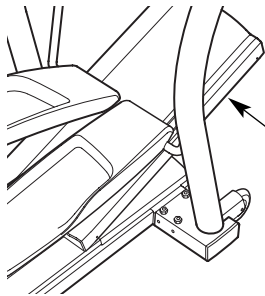

Serial Number
Decal
(beneath
ramp)

USER'S MANUAL

QUESTIONS?

As a manufacturer, we are committed to providing complete customer satisfaction. If you have questions, or if parts are damaged or missing, **PLEASE DO NOT CONTACT THE STORE; please contact Customer Care.**

IMPORTANT: You must note the product model number and serial number (see the drawing above) before contacting us:

CALL TOLL-FREE:

1-888-533-1333

Mon.-Fri. 6 a.m.-6 p.m. MST

Sat. 8 a.m.-4 p.m. MST

ON THE WEB:

www.proformservice.com

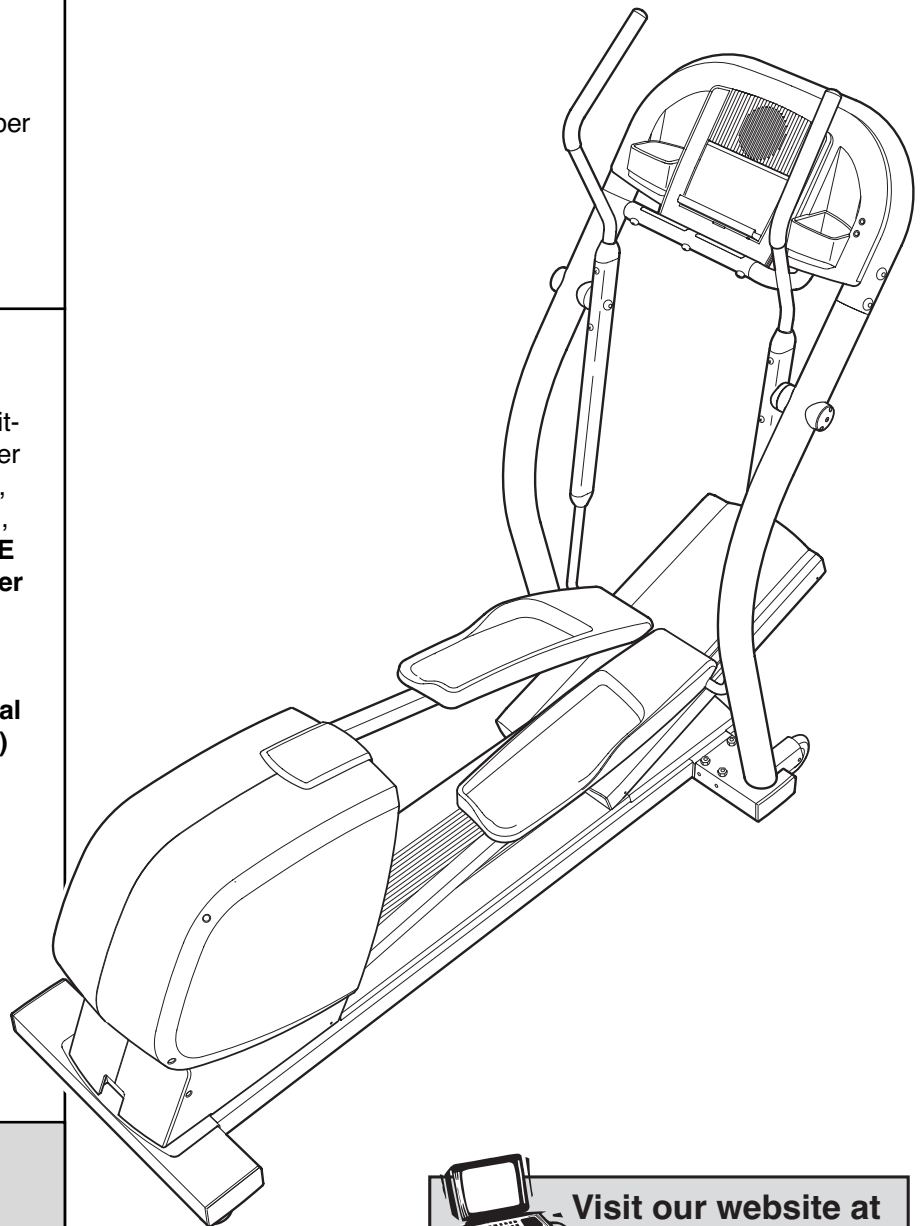

CAUTION

Read all precautions and instructions in this manual before using this equipment. Keep this manual for future reference.



Visit our website at

www.proform.com

new products, prizes,
fitness tips, and much more!

TABLE OF CONTENTS

WARNING DECAL PLACEMENT2
IMPORTANT PRECAUTIONS3
BEFORE YOU BEGIN4
ASSEMBLY5
HOW TO USE THE ELLIPTICAL EXERCISER10
MAINTENANCE AND TROUBLESHOOTING22
EXERCISE GUIDELINES23
PART LIST24
EXPLODED DRAWING26
ORDERING REPLACEMENT PARTSBack Cover
LIMITED WARRANTYBack Cover

WARNING DECAL PLACEMENT

The warning decals shown here have been applied in the locations shown. **If a decal is missing or illegible, call the telephone number on the front cover of this manual and request a free replacement decal. Apply the decal in the location shown.** Note: The decal may not be shown at actual size.

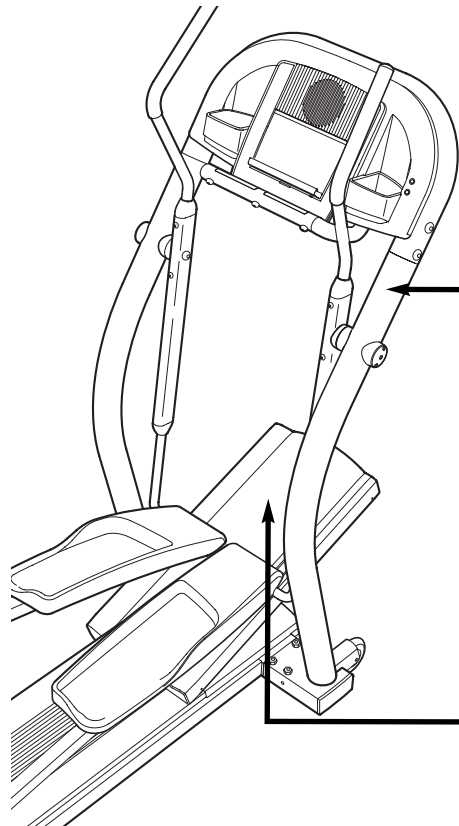

WARNING

- Misuse of this machine may result in serious injury.
- Read user's manual prior to use and follow all warnings and instructions.
- Do not allow children on or around machine.
- Pedals continue to spin when you stop pedaling.
- Spinning pedals can cause injury.
- Reduce pedal speed in a controlled manner.
- User weight must not exceed 300 pounds.
- Replace label if damaged, illegible, or removed.

WARNING

Keep hands and feet away from ramp while in operation.

IMPORTANT PRECAUTIONS

⚠️ WARNING: To reduce the risk of serious injury, read all important precautions and instructions in this manual and all warnings on your elliptical exerciser before using your elliptical exerciser. ICON assumes no responsibility for personal injury or property damage sustained by or through the use of this product.

1. Before beginning any exercise program, consult your physician. This is especially important for persons over the age of 35 or persons with pre-existing health problems.
2. It is the responsibility of the owner to ensure that all users of the elliptical exerciser are adequately informed of all precautions.
3. Your elliptical exerciser is intended for home use only. Do not use your elliptical exerciser in a commercial, rental, or institutional setting.
4. Keep your elliptical exerciser indoors, away from moisture and dust. Place your elliptical exerciser on a level surface, with a mat beneath it to protect the floor or carpet. Make sure that there is enough clearance around your elliptical exerciser to mount, dismount, and use it.
5. Inspect and properly tighten all parts regularly. Replace any worn parts immediately.
6. Keep children under age 12 and pets away from your elliptical exerciser at all times.
7. Your elliptical exerciser should not be used by persons weighing more than 300 lbs. (136 kg).
8. Wear appropriate exercise clothes when exercising; do not wear loose clothes that could become caught on your elliptical exerciser. Always wear athletic shoes for foot protection.
9. Hold the handgrip pulse sensor or the handlebars when mounting, dismounting, or using your elliptical exerciser.
10. Keep your back straight while using your elliptical exerciser; do not arch your back.
11. The pulse sensor is not a medical device. Various factors, including the user's movement, may affect the accuracy of heart rate readings. The pulse sensor is intended only as an exercise aid in determining heart rate trends in general.
12. When you stop exercising, allow the pedals to slowly come to a stop.
13. If you feel pain or dizziness while exercising, stop immediately and cool down.
14. Use your elliptical exerciser only as described in this manual.
15. Always unplug the power cord immediately after use and before cleaning the elliptical exerciser.

BEFORE YOU BEGIN

Congratulations for selecting the new PROFORM® CLUB DESIGN 1000 elliptical exerciser. The CLUB DESIGN 1000 elliptical exerciser is an incredibly smooth exerciser that moves your feet in a natural elliptical path, minimizing the impact on your knees and ankles.

For your benefit, read this manual carefully before you use the elliptical exerciser. If you have ques-



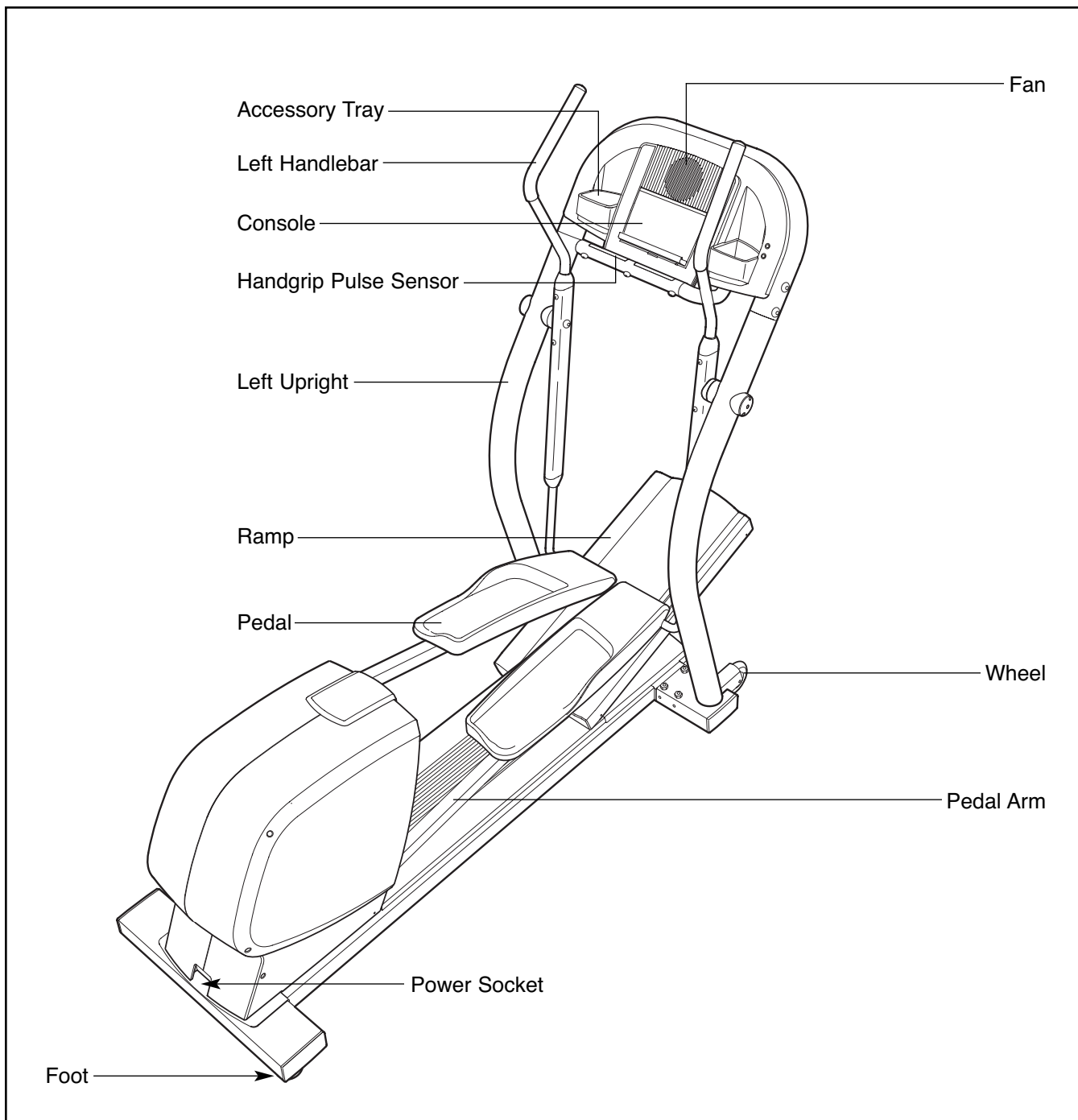

tions after reading this manual, please see the front cover of this manual. To help us assist you, note the product model number and serial number before contacting us. The model number and the location of the serial number decal are shown on the front cover of this manual.

Before reading further, please familiarize yourself with the parts that are labeled in the drawing below.

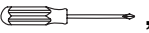

ASSEMBLY

To hire an authorized service technician to assemble the elliptical exerciser, call 1-800-445-2480.

Assembly requires two persons. Place all parts of the elliptical exerciser in a cleared area and remove the packing materials. Do not dispose of the packing materials until assembly is completed. **In addition to the included tools, assembly requires a Phillips screwdriver** , **two adjustable wrenches** , **a rubber mallet** , and **pliers** .

Use the drawings below to identify the small parts required for assembly. The number in parentheses below each drawing is the key number of the part, from the PART LIST near the end of this manual. The number following the key number is the quantity needed for assembly. **Note: Some small parts may have been pre-assembled. If a part is not in the hardware kit, check to see if it has been preassembled.**

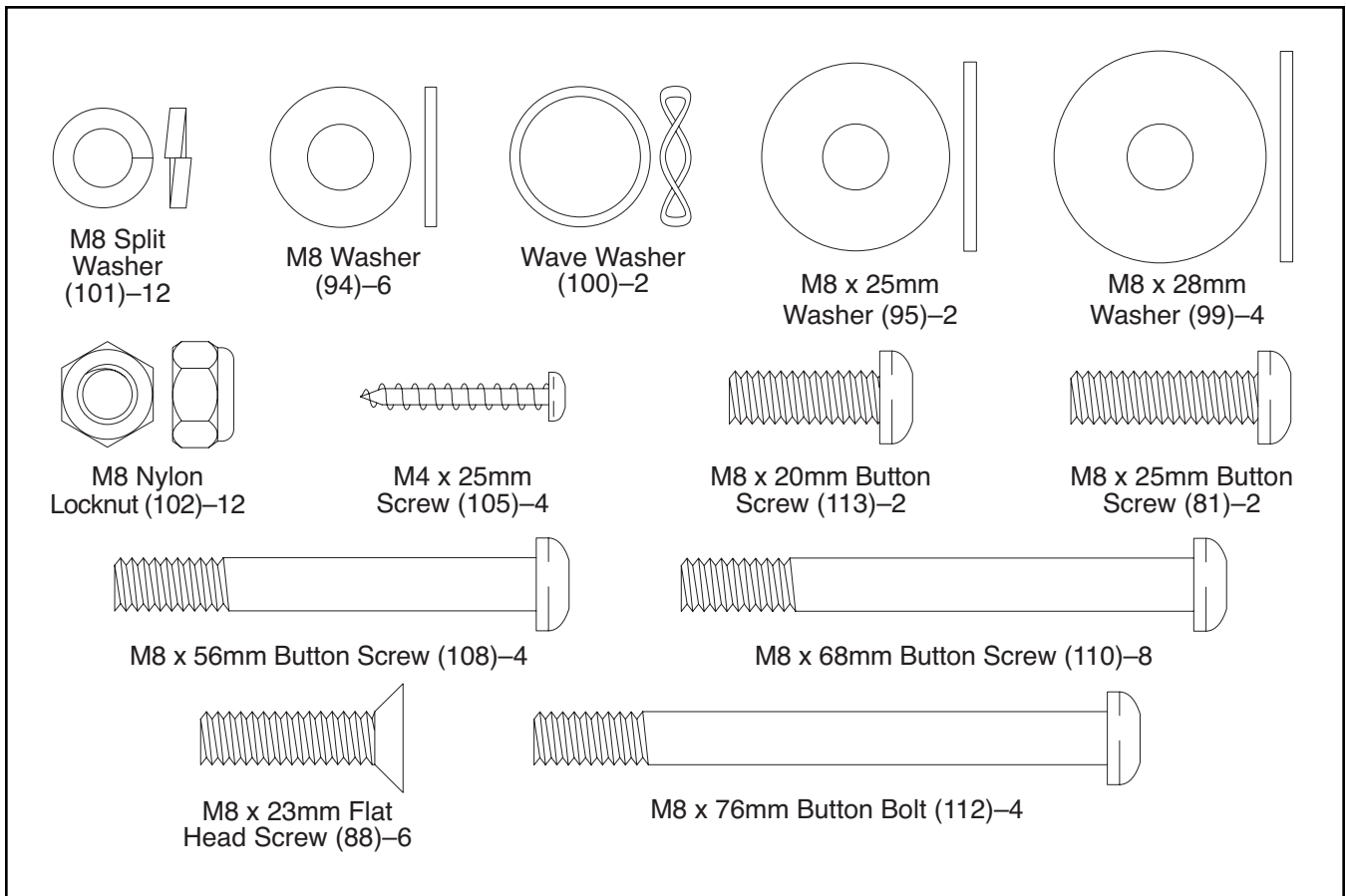

1.

To make assembly easier, read the information on page 5 before you begin assembling the elliptical exerciser.

Remove the Pivot Arms (not shown) and the plastic inserts from the Left and Right Uprights (4, 3).

Identify the Left Upright (4) and hold it near the Frame (1). Connect the Extension Wire Harness (76) to the Lower Wire Harness (77). While another person lifts the left side of the Frame, pull up on the Extension Wire Harness and insert the Left Upright into the Frame. Attach the Left Upright with two M8 x 56mm Button Screws (108), two M8 x 68mm Button Screws (110), and four M8 Split Washers (101); **be careful to avoid pinching the Wire Harnesses.**

Tighten a Frame Cushion (32) into the left side of the Frame (1) in the indicated location.

While the other person lifts the right side of the Frame (1), attach the Right Upright (3) in the same way. Note: There are no wire harnesses on the right side.

Tighten the other Frame Cushion (32) into the right side of the Frame (1).

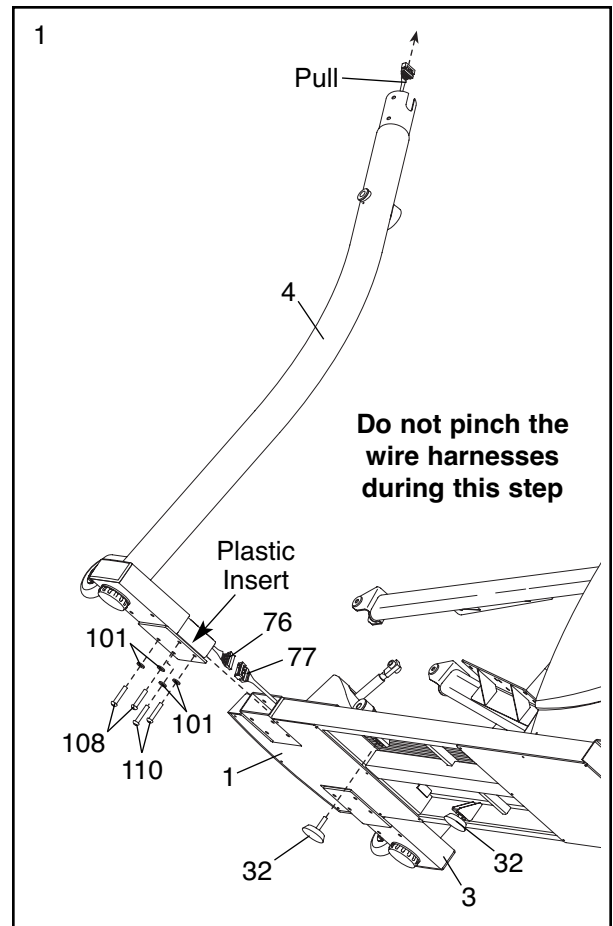

2. While another person holds the Console Frame (6) near the Uprights (3, 4), connect the Upper Wire Harness (75) to the Extension Wire Harness (76). Push the excess Wire Harness down into the left Upright. Next, attach the Console Frame to the Uprights with four M8 x 76mm Button Bolts (112) and four M8 Nylon Locknuts (102); **be careful to avoid pinching the Wire Harnesses as you slide the Console Frame onto the Uprights and insert the Button Bolts.**

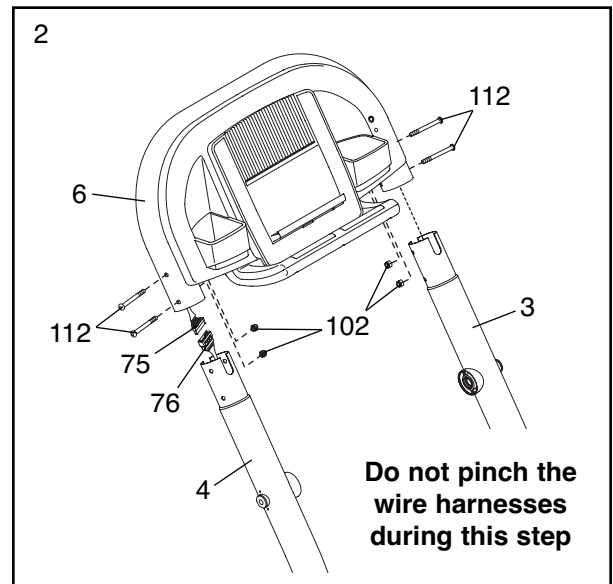

- Slide an M8 x 28mm Washer (99) onto an M8 x 20mm Button Screw (113). Tighten the Button Screw into one end of the Incline Axle (40). Apply a small amount of the included grease to the Incline Axle.

Orient the Ramp (5) so that the straight end is in the position shown. Hold the welded tube on the bottom of the Ramp between the two rings on the top of the Frame. Insert the Incline Axle (40) through the rings and the welded tube.

Slide an M8 x 28mm Washer (99) onto an M8 x 20mm Button Screw (113). Tighten the Button Screw into the open end of the Incline Axle (40).

Be careful not to scratch the Ramp (5) during steps 4 through 6.

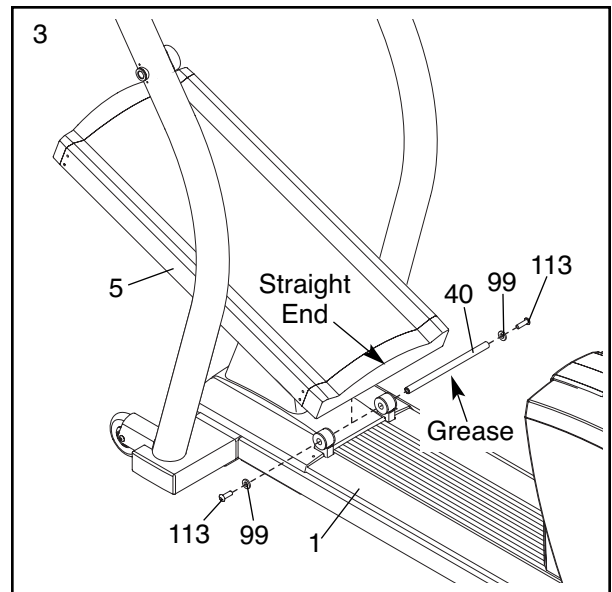

- Using your fingers, turn the shaft on top of the Lift Motor (42) counterclockwise until it stops turning. Position the U-bracket on the bottom of the Ramp (5) over the end of the shaft as shown. Next, hold an Incline Motor Spacer (60) on each side of the shaft, between the shaft and the U-bracket.

Next, insert the Short Clevis Pin (118) through the U-bracket on the Ramp (5), the shaft on the Lift Motor (42), and the two Incline Motor Spacers (60). Insert the straight end of a Hairpin (71) into the end of the Short Clevis Pin.

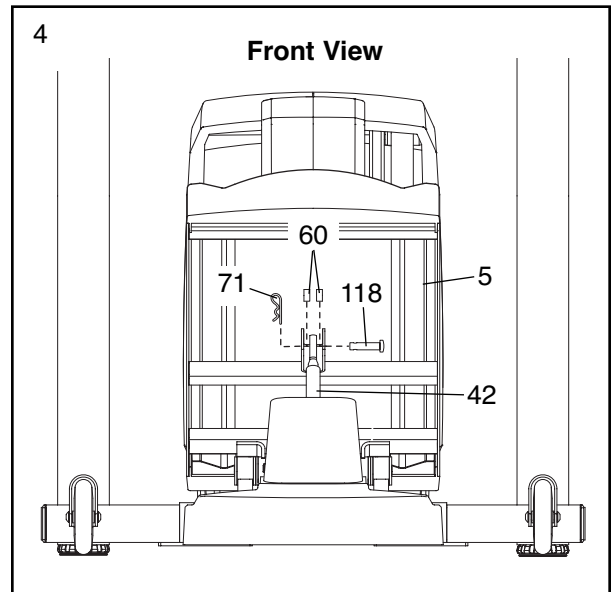

- See the inset drawing. While another person tips the elliptical exerciser as shown, place a sturdy piece of packaging foam beneath the elliptical exerciser. **Have the other person continue to hold the elliptical exerciser to steady it during this step.**

Orient the Rear Stabilizer (2) so that the holes are closer to the front. Attach the Rear Stabilizer to the rear of the Frame (1) with four M8 x 68mm Button Screws (110) and four M8 Split Washers (101).

Carefully remove the piece of packaging foam and tip the elliptical exerciser back down.

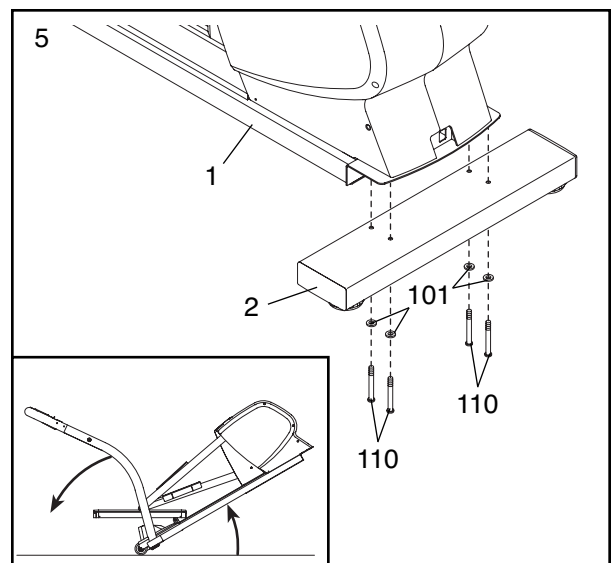

6. Apply a small amount of grease to the axle on each Pivot Shaft (15).

Hold a Pedal Wheel (35) inside of the bracket on the end of the Right Pedal Arm (11). Next, insert a Pivot Shaft (15) through the holes in the end of the Right Pedal Arm and the Pedal Wheel as indicated. Tighten an M8 Nylon Locknut (102) with an M8 x 25mm Washer (95) onto the end of the Pivot Shaft.

Attach the other Pivot Shaft (15) and the other Pedal Wheel (35) to the Left Pedal Arm (12) in the same way.

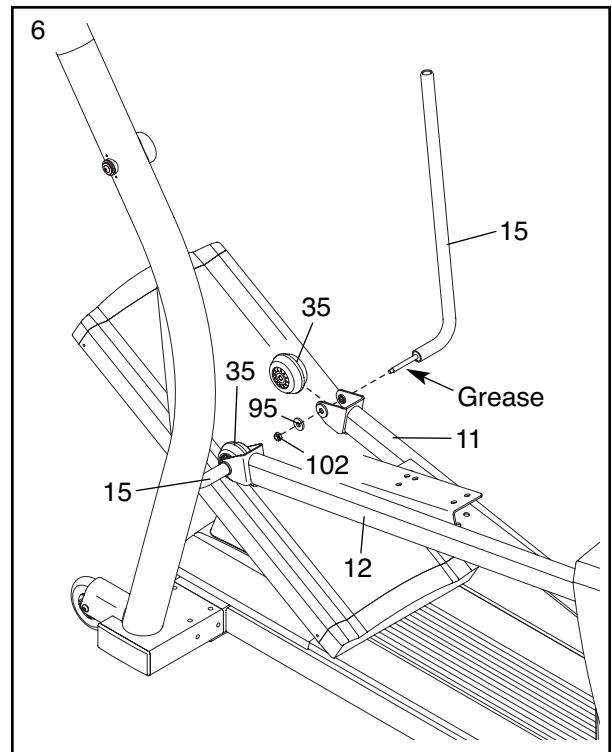

7. Identify the Left Pedal (14). Attach the Left Pedal to the Left Pedal Arm (12) with three M8 x 23mm Flat Head Screws (88), three M8 Washers (94), and three M8 Nylon Locknuts (102). Then, press the Left Pedal Insert (121) onto the Left Pedal.

Attach the Right Pedal (13) to the Right Pedal Arm (not shown), and press the Right Pedal Insert (122) into the Right Pedal, in the same way.

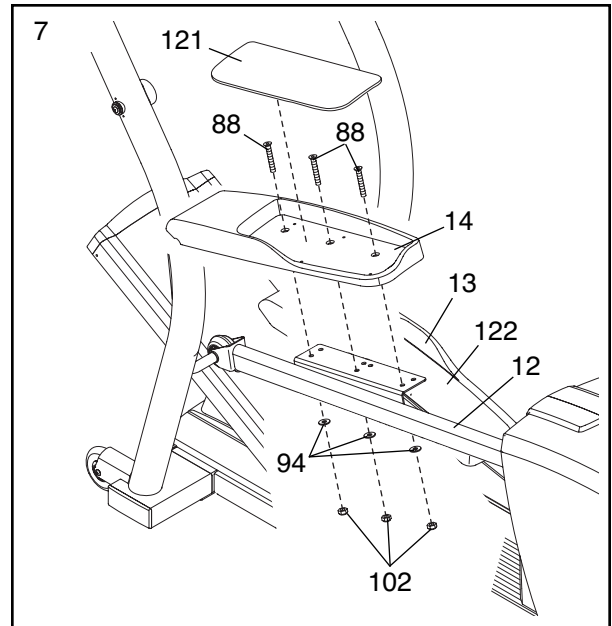

8. Apply a thin film of the included high-temperature lubricant to both Pivot Shafts (15).

Identify the Right Handlebar (9), which is marked with a sticker. Apply a small amount of grease to the axle on the Right Handlebar, to the Pivot Arm Cover (64), and to the Inner Upright Cover (63).

Next, slide the Right Handlebar (9) onto the right Pivot Shaft (15), and insert the axle on the Right Handlebar into the Right Upright (3). **Note: Position the Right Pedal (13) near the top of the Ramp (5), and lift and push the Right Pedal sideways, toward the center of the Ramp, to insert the axle into the Right Upright.**

Next, slide a Wave Washer (100) onto the end of the axle on the Right Handlebar (9). Apply a small amount of grease to an M8 x 28mm Washer (99), slide the Washer onto an M8 x 25mm Button Screw (81), and tighten the Button Screw into the axle. Then, attach an Outer Upright Cover (74) to the Right Upright (3) with two M4 x 25mm Screws (105).

Attach the Left Handlebar (10) to the left Pivot Shaft (15) and the Left Upright (4) in the same way.

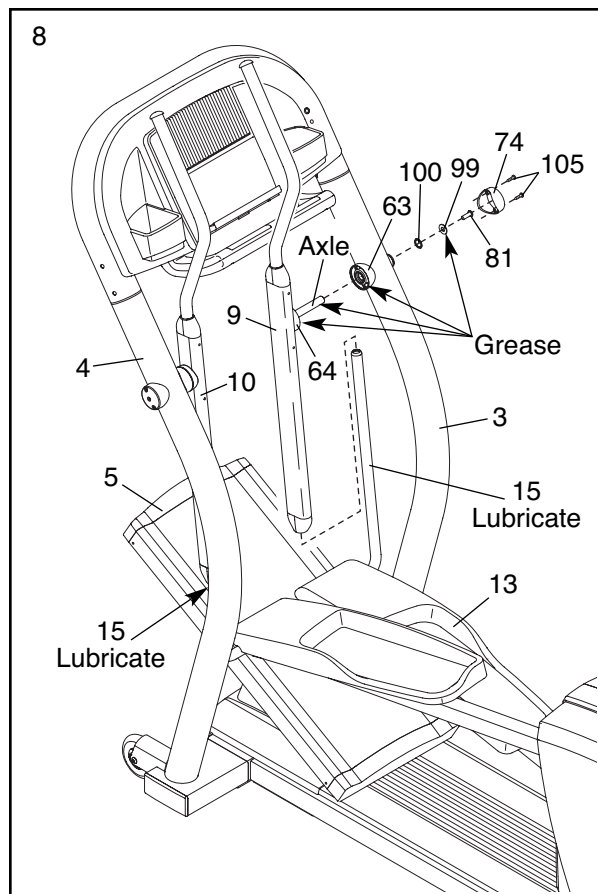

9. Plug the Power Cord (8) into the Power Receptacle (68) at the rear of the elliptical exerciser.

Next, plug the Power Cord (8) into an appropriate outlet as described on page 10, and calibrate the elliptical exerciser's incline system by following the steps on page 22.

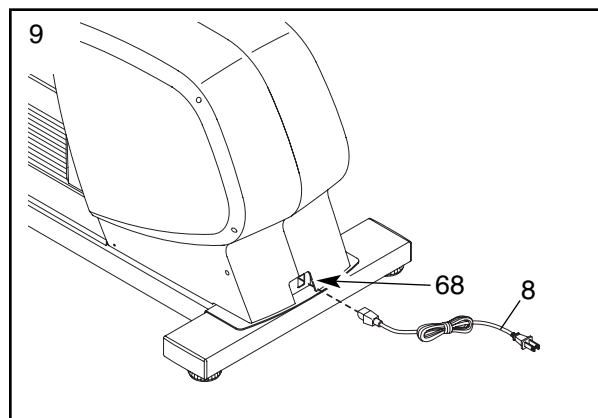

10. **Make sure that all parts of the elliptical exerciser are properly tightened.** Cover the floor beneath the elliptical exerciser to protect the floor from damage. Note: Some extra hardware may be left over.

HOW TO USE THE ELLIPTICAL EXERCISER

HOW TO PLUG IN THE POWER CORD

This product must be grounded. If it should malfunction or break down, grounding provides a path of least resistance for electric

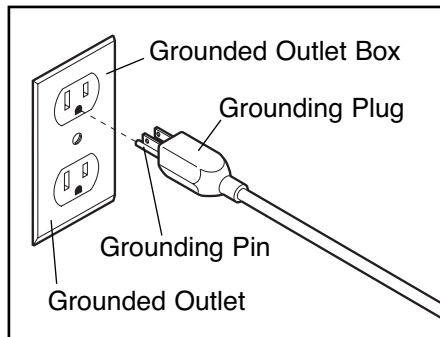

current to reduce the risk of electric shock. This product is equipped with a cord having an equipment-grounding conductor and a grounding plug. **Plug the power cord into an appropriate outlet that is properly installed and grounded in accordance with all local codes and ordinances. This product is for use on a nominal 120-volt circuit. IMPORTANT: The elliptical exerciser is not compatible with GFCI-equipped outlets.**

⚠ DANGER: Improper connection of the equipment-grounding conductor can result in an increased risk of electric shock. Check with a qualified electrician or serviceman if you are in doubt as to whether the product is properly grounded. Do not modify the plug provided with the product—if it will not fit the outlet, have a proper outlet installed by a qualified electrician.

A temporary adapter may be used to connect the power cord to a 2-pole receptacle as shown at the right if a properly grounded outlet is not available. The temporary adapter should be used only until a properly grounded outlet can be installed by a qualified electrician.

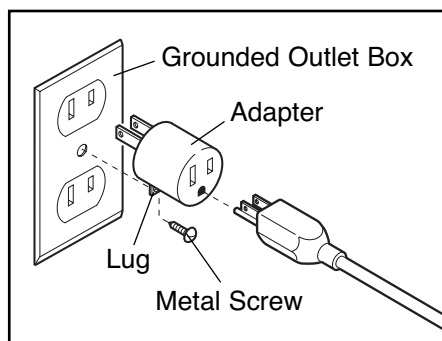

The green-colored rigid ear, lug, or the like extending from the adapter must be connected to a permanent ground such as a properly grounded outlet box cover. Whenever the adapter is used, it must be held in place by a metal screw. **Some 2-pole receptacle outlet box covers are not grounded. Contact a qualified electrician to determine if the outlet box cover is grounded before using an adapter.**

Note: When the power cord is plugged in, the elliptical exerciser's incline system may automatically calibrate itself. During the calibration process, three dashes (---) will appear in the console display, and the ramp will rise to the highest position and then sink to the lowest position. The calibration process will last for one to two minutes. If the incline system does not calibrate itself, see **HOW TO CALIBRATE THE INCLINE SYSTEM** on page 22.

EXERCISING ON THE ELLIPTICAL EXERCISER

To mount the elliptical exerciser, hold the handlebars and step onto the pedal that is in the lowest position. Next, step onto the other pedal. Push the pedals until they begin to move with a continuous motion.

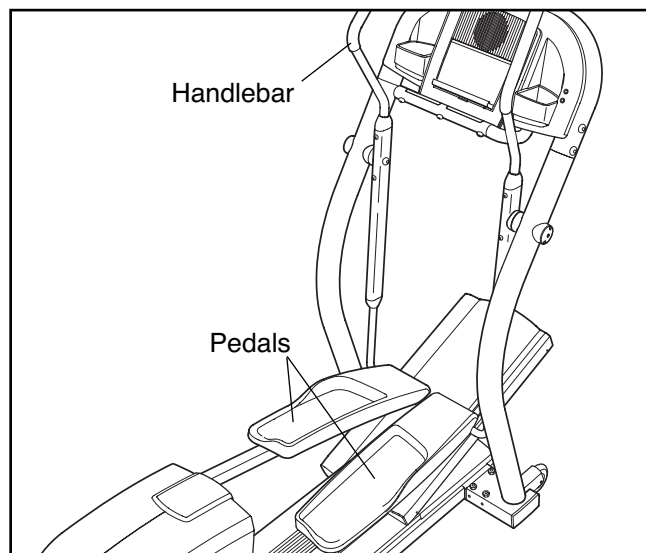

To dismount the elliptical exerciser, wait until the pedals come to a complete stop. **The elliptical exerciser does not have a free wheel; the pedals will continue to move until the flywheel stops.** When the pedals are stationary, step off the highest pedal first. Then, step off the lowest pedal.

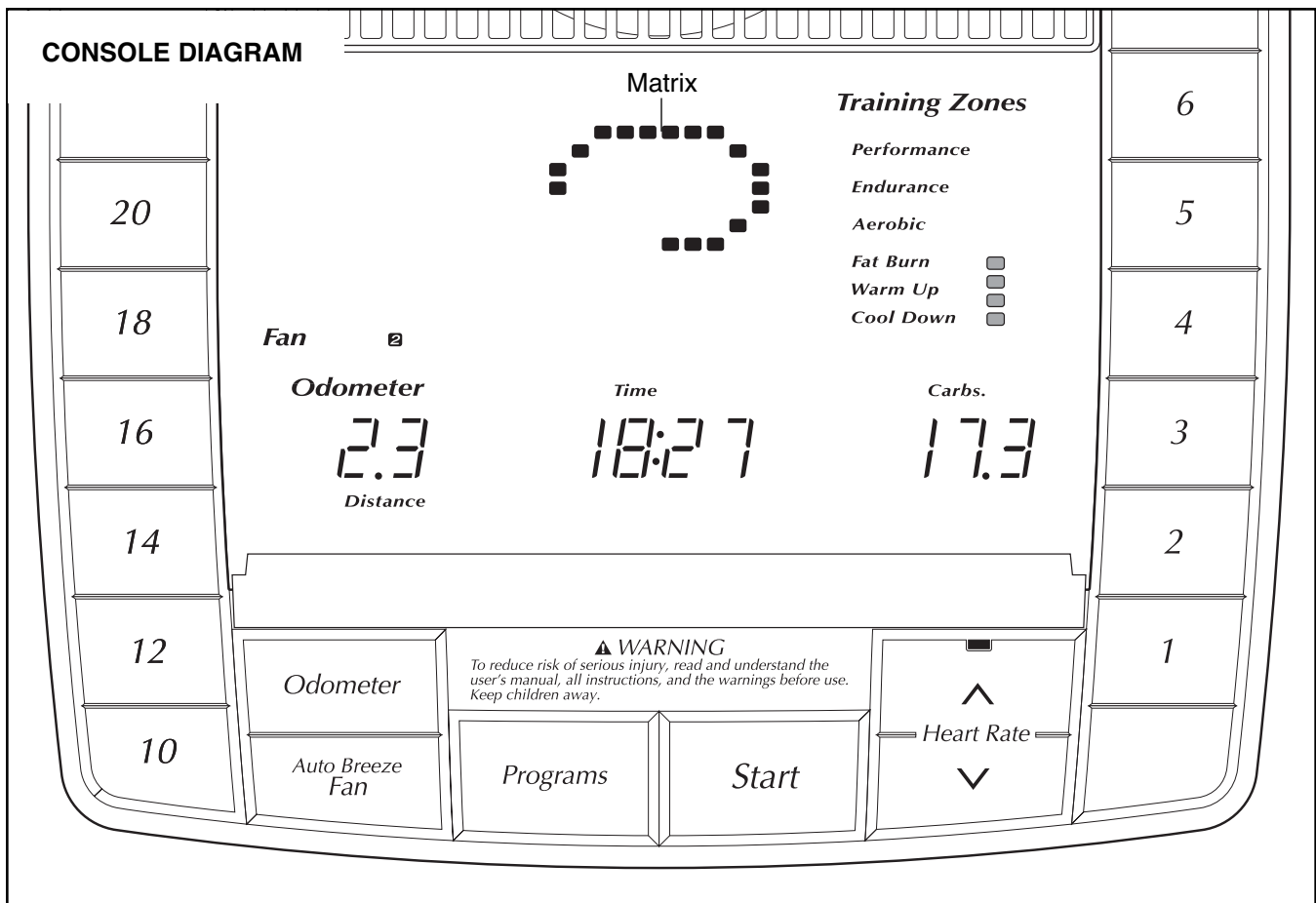

FEATURES OF THE CONSOLE

The advanced console offers a selection of features designed to make your workouts more enjoyable and effective. When the manual mode of the console is selected, the resistance of the elliptical exerciser and the angle of the ramp can be changed with the touch of a button. As you exercise, the console will provide continuous exercise feedback. You can even measure your heart rate using the handgrip pulse sensor.

The console also offers fifteen preset programs. Each program automatically changes the resistance of the elliptical exerciser and prompts you to increase or decrease your pace as it guides you through an effective workout.

In addition, the console features four heart rate programs that automatically change the resistance of the elliptical exerciser and prompt you to vary your pace to keep your heart rate near a target level as you exercise.

The console also features iFIT.com interactive technology. Having iFIT.com technology is like having a personal trainer in your home. Using a stereo audio cable, you can connect the elliptical exerciser to your portable stereo, home stereo, computer, or VCR and

play special iFIT.com MP3, CD, and video programs (iFIT.com MP3 programs, CDs, and videocassettes are available separately). iFIT.com programs automatically control the resistance of the elliptical exerciser and prompt you to vary your pace as a personal trainer coaches you through every step of your workout. High-energy music provides added motivation. **To purchase and download iFIT.com MP3 programs, go to www.iFIT.com. To purchase iFIT.com CDs and videocassettes, call the telephone number on the front cover of this manual.**

With the elliptical exerciser connected to your computer, you can also go to our website at www.iFIT.com and access programs directly from the Internet. **Explore www.iFIT.com for more information.**

To use the manual mode of the console, follow the steps beginning on page 12. **To use a preset program**, see page 14. **To use a heart rate program**, see page 15. **To use an iFIT.com MP3, CD, or video program**, see page 20. **To use an iFIT.com program directly from our website**, see page 21.

Note: If there is a sheet of clear plastic on the face of the console, remove it before using the console.

HOW TO USE THE MANUAL MODE

1. **Press any button on the console or begin pedaling to turn on the console.**

Make sure that the power cord is properly plugged in (see page 10). Next, press any button on the console or begin pedaling to turn on the console. After a few seconds, the console displays will light. A tone will then sound and the console will be ready for use.

2. **Select the manual mode.**

When the power is turned on, the manual mode will be selected. If you have selected a program or the iFIT.com mode, reselect the manual mode by pressing the Programs button repeatedly until a track appears in the matrix. Make sure that the letters "iFIT" do not appear in the center of the display.

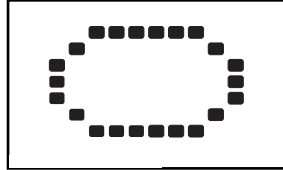

3. **Begin pedaling and change the resistance of the elliptical exerciser as desired.**

As you pedal, change the resistance of the elliptical exerciser by pressing the 1 Step Resistance buttons. Note: After the 1 Step Resistance buttons are pressed, it will take a moment for the elliptical exerciser to reach the selected resistance level.



4. **Adjust the angle of the ramp as desired.**

As you pedal, change the angle of the ramp by pressing the 1 Step Ramp buttons. Note: After the 1 Step Ramp buttons are pressed, it will take a moment for the ramp to reach the selected angle.

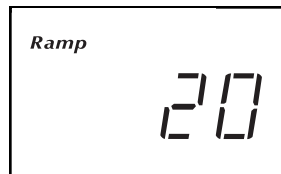

5. **Monitor your progress with the matrix, the Training Zones bar, and the displays.**

The matrix—When the manual mode or the iFIT.com mode is selected, the matrix will show a track representing 1/4 mile. As you exercise, the

indicators around the track will light in succession until the entire track is lit. The track will then darken and the indicators will again begin to light in succession.

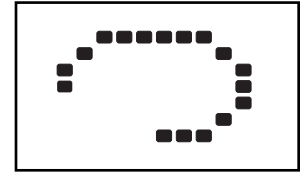

The Training Zones bar—The Training Zones bar will show the approximate intensity level of your exercise. If four indicators in the bar are lit, for example, the bar shows that your pace is ideal for fat burning.

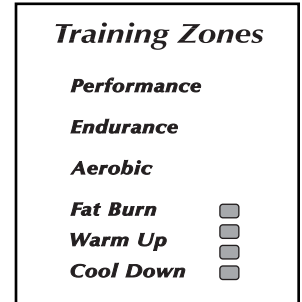

The Odometer display—The Odometer display will show the distance that you have pedaled during your workout.

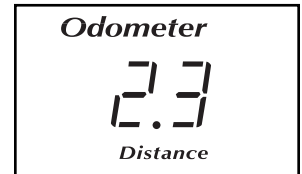

To see the total distance pedaled since the elliptical exerciser was purchased, press the Odometer button; the words "Total Miles" and the total number of miles will appear in the display.

To see the total distance pedaled during a recent time period, such as the most recent month, press the Odometer button again; the words "My Miles" and the total number of miles will appear in the display. To reset this number, hold down the Odometer button for a few seconds.

To again see the distance that you have pedaled during your workout, press the Odometer button again.

The center display—The center display will show the elapsed time, the resistance level of the elliptical exerciser, your pedaling speed, your pedaling pace, in revolutions per minute (RPM), and the angle of the ramp. The display will change from one number to the next every few seconds. Note: When a program is selected, the display will show the time remaining in the program instead of the elapsed time.



The right display—

The right display will show the approximate number of grams of carbs you have burned and the approximate number of calories you have burned. The display will change from one number to the next every few seconds. The display will also show your heart rate when you use the handgrip pulse sensor.

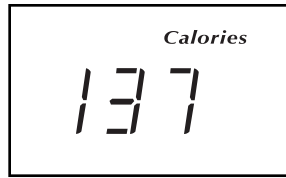

6. Measure your heart rate if desired.

If there are thin sheets of plastic on the metal contacts on the handgrip pulse sensor, peel off the plastic. To measure your heart rate, hold the contacts; your palms must be resting against the contacts. **Avoid moving your hands or gripping the contacts too tightly.**

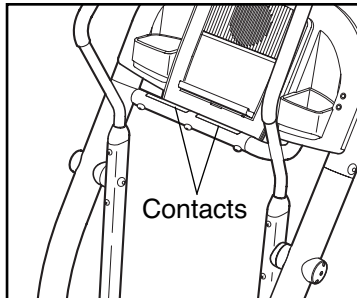

When your pulse is detected, one or two dashes (--) will appear in the right display, and then your heart rate will be shown. For the most accurate heart rate reading, hold the contacts for at least 15 seconds.

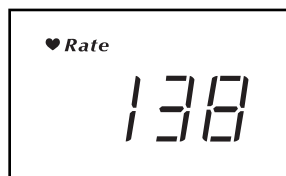

Note: If you continue to hold the pulse sensor, the right display will show your heart rate for up to 30 seconds. The display will then show your heart rate along with the other modes.

If your heart rate is not shown, make sure that your hands are positioned as described. Be careful not to move your hands excessively or to squeeze the metal contacts too tightly. For optimal performance, clean the metal contacts using a soft cloth; never use alcohol, abrasives, or chemicals.

7. Turn on the fan if desired.

To turn on the fan at low speed, press the Auto Breeze Fan button; the number 1 will appear next to the word "Fan" in the display. To turn on the fan at medium speed, press the button a second time; the number 2 will appear. To turn on the fan at high speed, press the button a third time; the number 3 will appear. To select the Auto mode, press the button again; the word "Auto" will appear. When the auto mode is selected, the speed of the fan will automatically increase and decrease as you increase and decrease your pedaling speed.

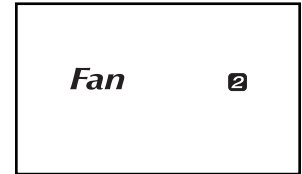

To turn off the fan, press the Auto Breeze Fan button again. Note: If the pedals are not turned for a few minutes, the fan will automatically turn off.

8. When you are finished exercising, the console will automatically turn off.

If the pedals are not moved for several seconds, a tone will sound, the console will pause, and the time will begin to flash in the center display.

If the pedals are not moved for about five minutes, the console will turn off and the displays will be reset.

HOW TO USE A PRESET PROGRAM

1. Press any button on the console or begin pedaling to turn on the console.

See step 1 on page 12.

2. Select one of the fifteen preset programs.

To select one of the fifteen preset programs, press the Programs button repeatedly until the words “Weight Loss,” “Aerobic,” or “Performance” and the number 1, 2, 3, 4, or 5 appear in the center of the display.

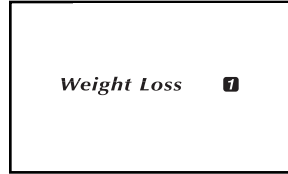

When a preset program is selected, a profile of the resistance settings of the program will scroll across the matrix. The center display will show how long the program will last.

3. Press the Start button or begin pedaling to start the program.

Each program is divided into several one-minute segments. One resistance setting and one pace setting are programmed for each segment. Note: The same resistance setting and/or pace setting may be programmed for two or more consecutive segments.

The resistance setting for the first segment will be shown in the flashing Current Segment column of the matrix. (The pace settings are not shown in the matrix.) The resistance settings for the next several segments will be shown in the columns to the right.

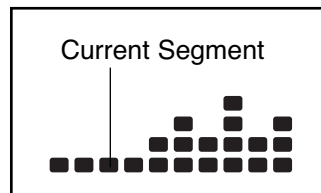

As you exercise, the Target Pace guide will help you to keep your pedaling pace near the pace setting for the current segment. When the words “Too Slow” appear in the display, increase your pace.

When the words “Too Fast” appear, decrease your pace. When the words “On Pace” appear, your pace matches the pace setting for the current segment.

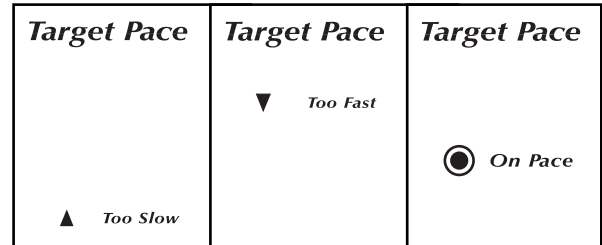

IMPORTANT: The pace settings are intended only to provide motivation. Your actual pace may be slower than the pace settings. Make sure to exercise at a pace that is comfortable for you.

When only three seconds remain in the first segment of the program, both the Current Segment column and the column to the right will flash, a series of tones will sound, and *all resistance settings will move one column to the left*. The resistance setting for the second segment will then be shown in the flashing Current Segment column, and the resistance of the elliptical exerciser will change to the resistance setting for the second segment. Note: If all of the indicators in the Current Segment column are lit after the resistance settings have moved to the left, *the resistance settings may move downward* so only the highest indicators appear in the matrix.

The program will continue until the resistance setting for the last segment is shown in the Current Segment column and the last segment ends.

Note: During the program, you can override the resistance setting for the current segment, if desired, by pressing the 1 Step Resistance buttons. However, when the next segment begins, the resistance will change if a different resistance setting is programmed for the next segment.

If you stop pedaling for several seconds, a tone will sound and the program will pause. To restart the program, simply resume pedaling.

4. Adjust the angle of the ramp as desired.

See step 4 on page 12.

5. Monitor your progress with the displays.

See step 5 on page 12.

6. Measure your heart rate if desired.

See step 6 on page 13.

7. Turn on the fan if desired.

See step 7 on page 13.

8. When the program is finished, the console will automatically turn off.

See step 8 on page 13.

HOW TO USE A HEART RATE PROGRAM

Each heart rate program helps you to keep your heart rate near a target heart rate setting during your workout.

Follow the steps below to use a heart rate program.

1. Press any button on the console or begin pedaling to turn on the console.

See step 1 on page 12.

2. Select one of the four heart rate programs.

To select a heart rate program, press the Programs button repeatedly until the words "Heart Rate" and the number 1, 2, 3, or 4 appear in the center of the display.

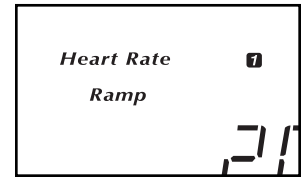

As each heart rate program is selected, a profile of the target heart rate settings of the selected program will scroll across the matrix. The center display will show how long the program will last.

3. Enter a maximum target heart rate setting.

When a heart rate program is selected, the heart symbol and the word "RATE" will appear in the right display and the maximum target heart rate setting will flash. If desired, press the Heart Rate buttons to change the maximum target heart rate setting.



4. Hold the handgrip pulse sensor.

To use a heart rate program, you must use the handgrip pulse sensor (see step 6 on page 13). It is not necessary to hold the handgrips continuously during the program. However, you should hold the handgrips frequently for the program to operate properly. **Each time you hold the handgrips, keep your hands on the metal contacts for at least 30 seconds.**

5. Press the Start button to start the program.

Each heart rate program is divided into one-minute segments. One target heart rate setting is programmed for each segment. Note: The same target heart rate setting may be programmed for two or more consecutive segments.

The target heart rate setting for the first segment will be shown in the flashing Current Segment column of the matrix. The target heart rate settings for the next seven segments will be shown in the columns to the right.

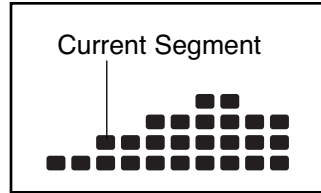

When only three seconds remain in the first segment of the program, both the Current Segment column and the column to the right will flash, a series of tones will sound, and *all target heart rate settings will move one column to the left*. The target heart rate setting for the second segment will then be shown in the flashing Current Segment column.

As you pedal, the console will regularly compare your heart rate to the target heart rate setting. If your heart rate is too far below or above the target heart rate setting, the resistance of the elliptical exerciser will automatically increase or decrease to bring your heart rate closer to the target heart rate setting.

The Target Pace guide will prompt you to increase or decrease your pedaling pace during the program. When the words "Too Slow" appear in the display, increase your pace. When the words "Too Fast" appear, decrease your pace. When the words "On Pace" appear, maintain your current pace.

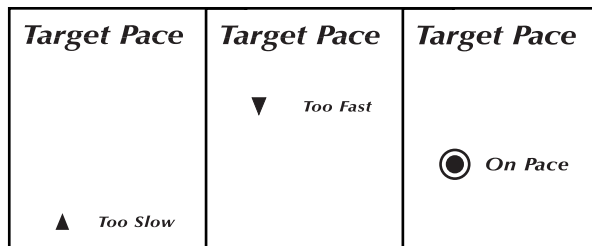

IMPORTANT: The target heart rate settings are intended only to provide motivation. Your actual heart rate may be slower than the target heart rate settings. Make sure to exercise at a pace that is comfortable for you.

The program will continue until the target heart rate setting for the last segment is shown in the Current Segment column of the matrix and the last segment ends.

Note: During the program, you can manually override the resistance setting for the current segment, if desired, with the 1 Step Resistance buttons. However, when the console compares your heart rate to the target heart rate setting, the resistance of the elliptical exerciser may automatically increase or decrease to bring your heart rate closer to the target heart rate setting.

If you stop pedaling for several seconds, a tone will sound and the program will pause. To restart the program, simply resume pedaling.

6. Adjust the angle of the ramp as desired.

See step 4 on page 12.

7. Monitor your progress with the displays.

See step 5 on page 12.

8. Turn on the fan if desired.

See step 7 on page 13.

9. When the program is finished, the console will automatically turn off.

See step 8 on page 13.

HOW TO CONNECT THE ELLIPTICAL EXERCISER TO USE IFIT.COM PROGRAMS

To use **iFIT.com MP3 or CD programs**, the elliptical exerciser must be connected to your MP3 player, CD player, portable stereo, home stereo, or computer. See pages 17 and 18 for connecting instructions. **To use iFIT.com programs directly from our website**, the elliptical exerciser must be connected to your computer. See page 18 for connecting instructions. **To use iFIT.com video programs**, the elliptical exerciser must be connected to your VCR. See page 19 for connecting instructions.

HOW TO CONNECT YOUR MP3 PLAYER OR CD PLAYER

- A. Plug one end of the included 1/8" to 1/8" stereo audio cable into either jack on the console. Plug the other end of the cable into a jack on your MP3 player or CD player. Plug your headphones into the other jack on the console.

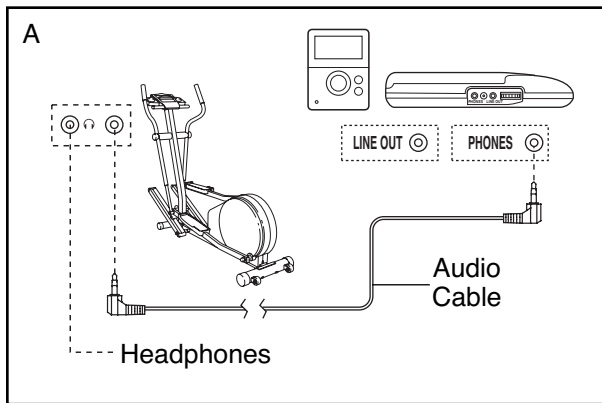

HOW TO CONNECT YOUR PORTABLE STEREO

Note: If your stereo has an RCA-type AUDIO OUT jack, see instruction A below. If your stereo has a 1/8" LINE OUT jack, see instruction B. If your stereo has only a PHONES jack, see instruction C.

- A. Plug one end of a long 1/8" to RCA stereo audio cable (available at electronics stores) into either jack on the console. Plug the other end of the cable into the AUDIO OUT jack on your stereo.

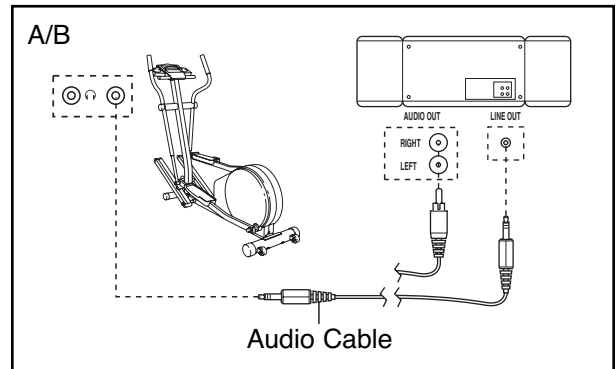

- B. See the drawing above. Plug one end of a long 1/8" to 1/8" stereo audio cable (available at electronics stores) into either jack on the console. Plug the other end of the cable into the LINE OUT jack on your stereo. Note: While the cable is plugged into the LINE OUT jack, do not plug your headphones into the other jack on the console.
- C. Plug one end of a long 1/8" to 1/8" stereo audio cable (available at electronics stores) into either jack on the console. Plug the other end of the cable into the PHONES jack on your stereo. Plug your headphones into the other jack on the console.

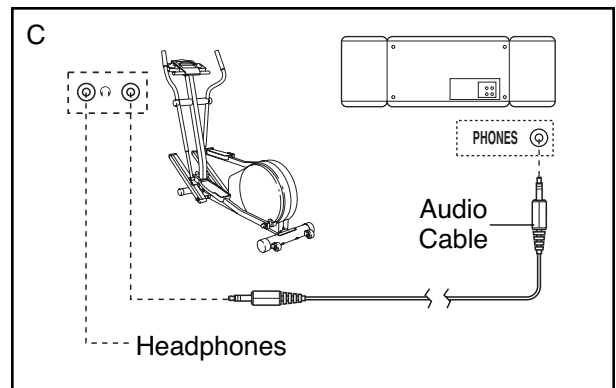

HOW TO CONNECT YOUR HOME STEREO

Note: If your stereo has an unused LINE OUT jack, see instruction A below. If the LINE OUT jack is being used, see instruction B.

- A. Plug one end of a long 1/8" to RCA stereo audio cable (available at electronics stores) into either jack on the console. Plug the other end of the cable into the LINE OUT jack on your stereo. Note: While the cable is plugged into the LINE OUT jack, do not plug your headphones into the other jack on the console.

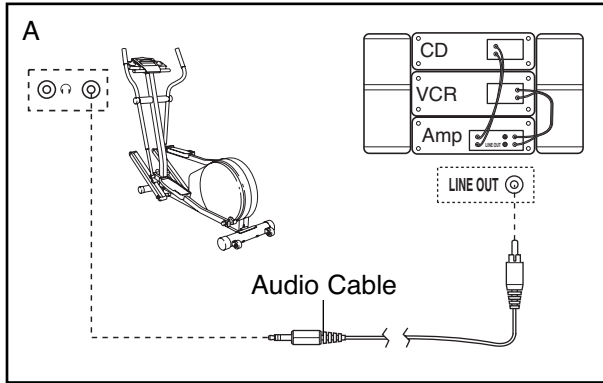

- B. Plug one end of a long 1/8" to RCA stereo audio cable (available at electronics stores) into either jack on the console. Plug the other end of the cable into an RCA Y-adapter (available at electronics stores). Next, remove the wire that is currently plugged into the LINE OUT jack on your stereo and plug the wire into the unused side of the Y-adapter. Plug the Y-adapter into the LINE OUT jack on your stereo. Note: While the Y-adapter is plugged into the LINE OUT jack, do not plug your headphones into the other jack on the console.

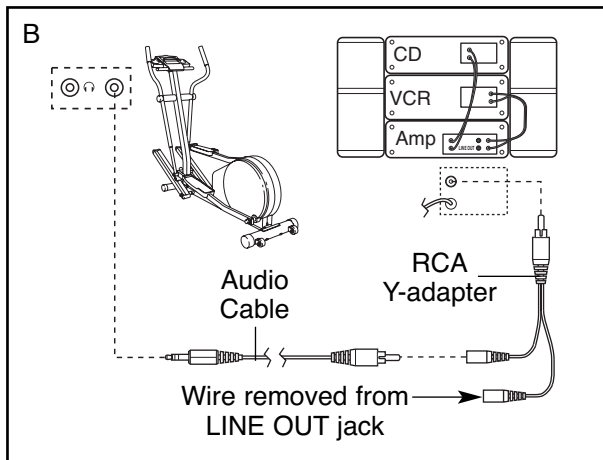

HOW TO CONNECT YOUR COMPUTER

- A. Plug one end of a long 1/8" to 1/8" stereo audio cable (available at electronics stores) into either jack on the console. Plug the other end of the cable into the LINE OUT jack on your computer. Note: While the cable is plugged into the LINE OUT jack, do not plug your headphones into the other jack on the console.

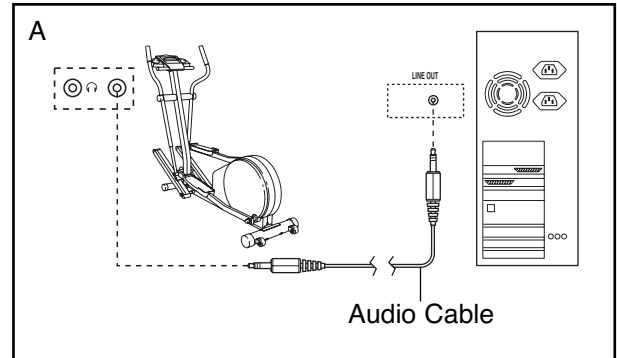

HOW TO CONNECT YOUR VCR

Note: If your VCR has an unused AUDIO OUT jack, see instruction A below. If the AUDIO OUT jack is being used, see instruction B. If you have a TV with a built-in VCR, see instruction B. If your VCR is connected to your home stereo, see HOW TO CONNECT YOUR HOME STEREO on page 18.

- A. Plug one end of a long 1/8" to RCA stereo audio cable (available at electronics stores) into either jack on the console. Plug the other end of the cable into the AUDIO OUT jack on your VCR.

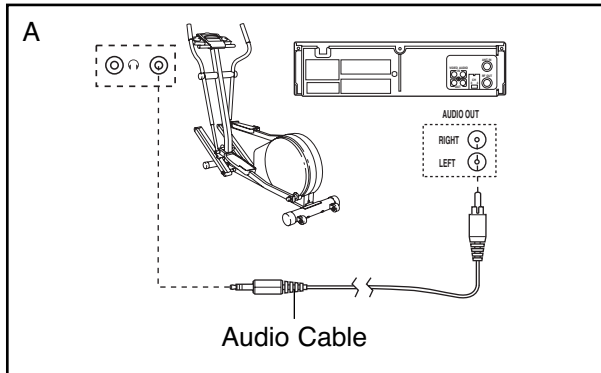

- B. Plug one end of a long 1/8" to RCA stereo audio cable (available at electronics stores) into either jack on the console. Plug the other end of the cable into an RCA Y-adapter (available at electronics stores). Next, remove the wire that is currently plugged into the AUDIO OUT jack on your VCR and plug the wire into the unused side of the Y-adapter. Plug the Y-adapter into the AUDIO OUT jack on your VCR.

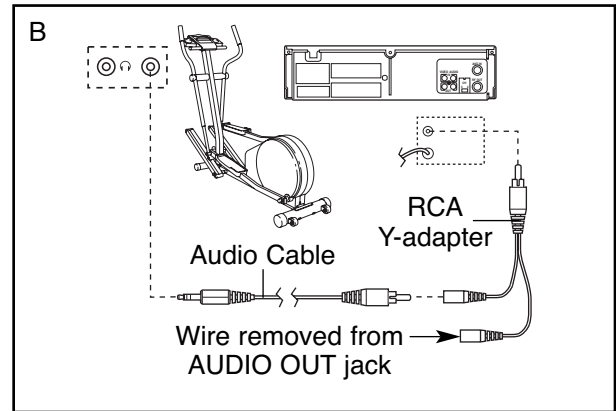

HOW TO USE AN iFIT.COM MP3, CD, OR VIDEO PROGRAM

To use an iFIT.com MP3, CD, or video program, the elliptical exerciser must be connected to your MP3 player, CD player, or VCR. See HOW TO CONNECT THE ELLIPTICAL EXERCISER TO USE iFIT.COM PROGRAMS on pages 17 to 19. **To purchase and download iFIT.com MP3 programs, go to www.iFIT.com. To purchase iFIT.com CDs or videocassettes, call the telephone number on the front cover of this manual.**

Follow the steps below to use an iFIT.com MP3, CD, or video program.

Follow the steps below to use an iFIT.com CD or video program.

1. Press any button on the console or begin pedaling to turn on the console.

See step 1 on page 12.

2. Select the iFIT.com mode.

To select the iFIT.com mode, press the Programs button repeatedly until the track and the letters "iFIT" light in the center of the display.

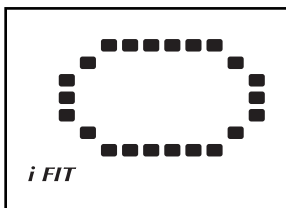

3. Press the Play button on your MP3 player, CD player, or VCR.

Note: If you are using an iFIT.com CD, insert the CD into your CD player; if you are using an iFIT.com videocassette, insert the videocassette into your VCR.

A moment after the play button is pressed, your personal trainer will begin guiding you through your workout. Simply follow your personal trainer's instructions.

The program will function in almost the same way as a preset program (see step 3 on page 14). However, an electronic "chirping" sound will alert you when the resistance setting and/or pace setting is about to change.

Note: If the resistance of the elliptical exerciser and/or the pace setting does not change when a "chirp" is heard:

- Make sure that the letters "iFIT" appear in the center of the display.
- Adjust the volume of your MP3 player, CD player, or VCR. If the volume is too high or too low, the console may not detect the program signals.
- Make sure that the audio cable is properly connected and that it is fully plugged in.

4. Adjust the angle of the ramp as desired.

See step 4 on page 12.

5. Monitor your progress with the displays.

See step 5 on page 12.

6. Measure your heart rate as desired.

See step 6 on page 13.

7. Turn on the fan if desired.

See step 7 on page 13.

8. When the program is finished, the console will automatically turn off.

See step 8 on page 13.

HOW TO USE PROGRAMS DIRECTLY FROM OUR WEBSITE

Our website at www.iFIT.com allows you to play iFIT.com programs directly from the Internet. To use programs from our website, the elliptical exerciser must be connected to your home computer. See HOW TO CONNECT YOUR COMPUTER on page 18. In addition, you must have an Internet connection and an Internet service provider. A list of specific system requirements is found on our website.

Follow the steps below to use a program from our website.

- 1. Press any button on the console or begin pedaling to turn on the console.**

See step 1 on page 12.

- 2. Select the iFIT.com mode.**

To select the iFIT.com mode, press the Programs button repeatedly until the track and the letters "iFIT" light in the center of the display.

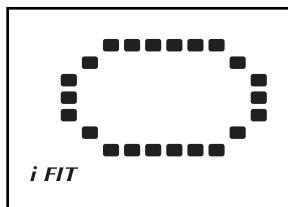

- 3. Go to your computer and start an Internet connection.**
- 4. Start your Web browser, if necessary, and go to our website at www.iFIT.com.**
- 5. Follow the desired links on our website to select a program.**

Read and follow the online instructions for using a program.

- 6. Follow the online instructions to start the program.**

When you start the program, an on-screen countdown will begin.

- 7. Return to the elliptical exerciser and begin pedaling.**

When the on-screen countdown ends, the program will begin. The program will function in almost the same way as a preset program (see step 3 on page 14). However, an electronic "chirping" sound will alert you when the resistance setting and/or pace setting is about to change.

- 8. Adjust the angle of the ramp if desired.**

See step 4 on page 12.

- 9. Monitor your progress with the displays.**

See step 5 on page 12.

- 10. Measure your heart rate if desired.**

See step 6 on page 13.

- 11. Turn on the fan if desired.**

See step 7 on page 13.

- 12. When the program is finished, the console will automatically turn off.**

See step 8 on page 13.

MAINTENANCE AND TROUBLESHOOTING

Inspect and properly tighten all parts of the elliptical exerciser regularly. Replace any worn parts immediately.

For smooth operation of the elliptical exerciser, **inspect and clean the ramp regularly** using a soft cloth and mild detergent. Other parts of the elliptical exerciser can also be cleaned in this way. **Keep liquids off the console. Never use abrasives or solvents.**

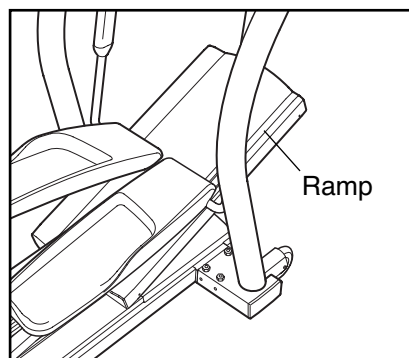

PULSE SENSOR TROUBLESHOOTING

If the handgrip pulse sensor does not function properly, see step 6 on page 13.

HOW TO CALIBRATE THE INCLINE SYSTEM

If the elliptical exerciser's incline system is not working properly, activate the calibration process by following the steps below.

1. Hold down the Start button and the Heart Rate increase button at the same time for about five seconds. Note: Numbers may appear in the display; disregard these numbers.
2. Press the Start button again. Note: A combination of letters and numbers will appear in the display.
3. Press the 30° 1 Step Ramp button. The ramp will rise to the highest position and then sink to the lowest position.
4. Press the Start button three times. The console will then be in the normal operating mode and the elliptical exerciser will be ready for use.

HOW TO MOVE THE ELLIPTICAL EXERCISER

Stand in front of the elliptical exerciser, hold the frame firmly, and place one foot against the ramp in the location shown below. Pull the frame until the elliptical exerciser can be moved on the front wheels, and carefully move the elliptical exerciser to the desired location. Then, place one foot against the ramp, and lower the elliptical exerciser. **Due to the size and weight of the elliptical exerciser, use extreme caution while moving and lowering it.**

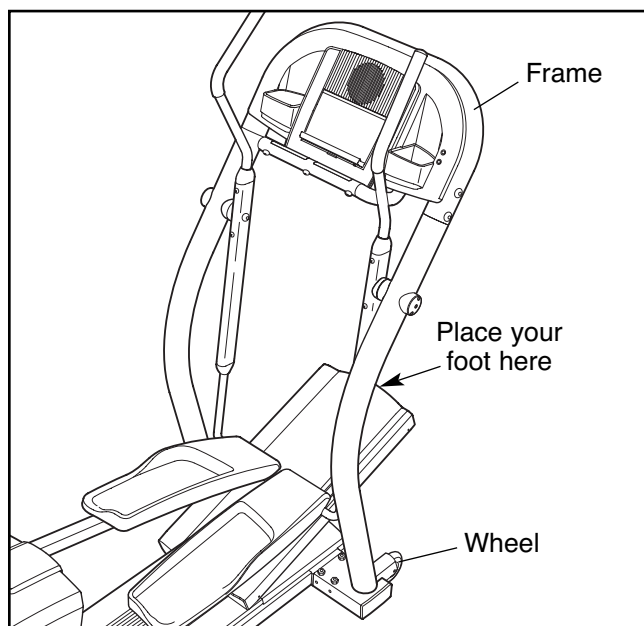

HOW TO LEVEL THE ELLIPTICAL EXERCISER

If the elliptical exerciser rocks during use, turn one or both of the leveling feet under the rear stabilizer until the rocking motion is eliminated.

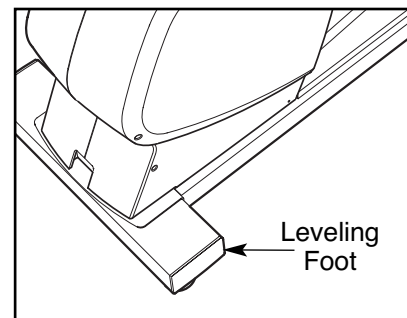

EXERCISE GUIDELINES

⚠ WARNING: Before beginning this or any exercise program, consult your physician. This is especially important for persons over the age of 35 or persons with pre-existing health problems.

The pulse sensor is not a medical device. Various factors may affect the accuracy of heart rate readings. The pulse sensor is intended only as an exercise aid in determining heart rate trends in general.

These guidelines will help you to plan your exercise program. For detailed exercise information, obtain a reputable book or consult your physician. Remember, proper nutrition and adequate rest are essential for successful results.

EXERCISE INTENSITY

Whether your goal is to burn fat or to strengthen your cardiovascular system, exercising at the proper intensity is the key to achieving results. You can use your heart rate as a guide to find the proper intensity level. The chart below shows recommended heart rates for fat burning and aerobic exercise.

165	155	145	140	130	125	115	♥
145	138	130	125	118	110	103	♥
125	120	115	110	105	95	90	♥
<hr/>							
20	30	40	50	60	70	80	

To find the proper intensity level, find your age at the bottom of the chart (ages are rounded off to the nearest ten years). The three numbers listed above your age define your “training zone.” The lowest number is the heart rate for fat burning, the middle number is the heart rate for maximum fat burning, and the highest number is the heart rate for aerobic exercise.

Burning Fat—To burn fat effectively, you must exercise at a low intensity level for a sustained period of time. During the first few minutes of exercise, your body uses *carbohydrate calories* for energy. Only after the first few minutes of exercise does your body begin to use stored *fat calories* for energy. If your goal is to burn fat, adjust the intensity of your exercise until your heart rate is near the lowest number in your training zone. For maximum fat burning, exercise with your heart rate near the middle number in your training zone.

Aerobic Exercise—If your goal is to strengthen your cardiovascular system, you must perform aerobic exercise, which is activity that requires large amounts of oxygen for prolonged periods of time. For aerobic exercise, adjust the intensity of your exercise until your heart rate is near the highest number in your training zone.

WORKOUT GUIDELINES

Warming up—Start with 5 to 10 minutes of stretching and light exercise. A warm-up increases your body temperature, heart rate, and circulation in preparation for exercise.

Training Zone Exercise—Exercise for 20 to 30 minutes with your heart rate in your training zone. (During the first few weeks of your exercise program, do not keep your heart rate in your training zone for longer than 20 minutes.) Breathe regularly and deeply as you exercise—never hold your breath.

Cooling down—Finish with 5 to 10 minutes of stretching. Stretching increases the flexibility of your muscles and helps to prevent post-exercise problems.

EXERCISE FREQUENCY

To maintain or improve your condition, complete three workouts each week, with at least one day of rest between workouts. After a few months of regular exercise, you may complete up to five workouts each week, if desired. Remember, the key to success is to make exercise a regular and enjoyable part of your everyday life.

PART LIST—Model No. PFEL09907.0

R0907A

Key No.	Qty.	Description	Key No.	Qty.	Description
1	1	Frame	48	1	Power Board Cover
2	1	Rear Stabilizer	49	1	Power Board
3	1	Right Upright	50	1	Power Board Bracket
4	1	Left Upright	51	1	Idler Pulley Bracket
5	1	Ramp	52	1	Reed Switch Clamp
6	1	Console Frame	53	1	Reed Switch
7	1	Lower Ramp Cap	54	2	Pillow Block Set
8	1	Power Cord	55	2	Bearing Block Set
9	1	Right Handlebar	56	4	Crank Arm Bushing
10	1	Left Handlebar	57	4	Pulley Spacer
11	1	Right Pedal Arm	58	1	Crank Spacer
12	1	Left Pedal Arm	59	4	Ramp Bushing
13	1	Right Pedal	60	4	Incline Motor Spacer
14	1	Left Pedal	61	4	Pedal Wheel Bushing
15	2	Pivot Shaft	62	4	Pivot Bushing
16	4	M4 Star Washer	63	2	Inner Upright Cover
17	1	Console	64	2	Pivot Arm Cover
18	1	Hand Grip Pulse Sensor	65	1	Magnet
19	1	Rear Base Plate	66	1	Wedge
20	1	Front Base Plate	67	1	Incline Reed Switch
21	1	Right Rear Side Shield	68	1	Power Receptacle
22	1	Left Rear Side Shield	69	1	Belt
23	1	Right Front Side Shield	70	1	Grommet
24	1	Left Front Side Shield	71	2	Hairpin
25	1	Front Cover	72	2	Snap Ring
26	1	Right Foot Rail	73	1	Flywheel Spacer
27	1	Left Foot Rail	74	2	Outer Upright Cover
28	1	Upper Ramp Cap	75	1	Upper Wire Harness
29	4	Pivot Shaft Sleeve	76	1	Extension Wire Harness
30	4	Handlebar Cover	77	1	Lower Wire Harness
31	4	Frame Endcap	78	4	M4 x 14mm Screw
32	2	Frame Cushion	79	4	M5 Nylon Locknut
33	4	Leveling Foot	80	2	M8 x 45mm Button Screw
34	2	Wheel	81	4	M8 x 25mm Button Screw
35	2	Pedal Wheel	82	4	M5 Washer
36	1	Flywheel	83	2	Flange Screw
37	1	Pulley	84	2	M8 x 52mm Button Screw
38	1	Right Crank Arm	85	2	M8 x 41mm Button Screw
39	1	Left Crank Arm	86	2	Large Wave Washer
40	1	Incline Axle	87	2	M8 x 16mm Washer
41	1	Pulley Axle	88	6	M8 x 23mm Flat Head Screw
42	1	Lift Motor	89	1	M8 x 57mm Screw
43	1	"C" Magnet	90	1	M6 x 38mm Bolt
44	1	Spring	91	1	Magnet Bracket Bolt
45	1	Small Pulley	92	36	M4 x 16mm Screw
46	1	Idler Pulley	93	1	M6 x 8mm Button Screw
47	1	Resistance Motor	94	7	M8 Washer

Key No.	Qty.	Description	Key No.	Qty.	Description
95	2	M8 x 25mm Washer	112	4	M8 x 76mm Button Bolt
96	3	M8 x 9.5mm Screw	113	2	M8 x 20mm Button Screw
97	5	M5 x 16mm Bolt	114	2	M6 Nut
98	2	M8 x 23mm Washer	115	4	M6 x 10mm Button Screw
99	4	M8 x 28mm Washer	116	5	M4 x 19mm Screw
100	2	Wave Washer	117	2	M4 x 30mm Screw
101	12	M8 Split Washer	118	1	Short Clevis Pin
102	13	M8 Nylon Locknut	119	1	Long Clevis Pin
103	2	Large Snap Ring	120	2	Foam Grip
104	2	Handlebar Endcap	121	1	Left Pedal Insert
105	8	M4 x 25mm Screw	122	1	Right Pedal Insert
106	8	M4 x 16mm Round Head Screw	123	1	Set Screw
107	2	Bolt Set	*	–	Hex Key
108	4	M8 x 56mm Button Screw	*	–	Grease Packet
109	1	Reed Switch Plate	*	–	High-temperature Lubricant
110	8	M8 x 68mm Button Screw	*	–	User's Manual
111	8	M4 x 12mm Screw			

Note: Specifications are subject to change without notice. See the back cover of this manual for information about ordering replacement parts. *These parts are not illustrated.

EXPLODED DRAWING A—Model No. PFEL09907.0

R0907A

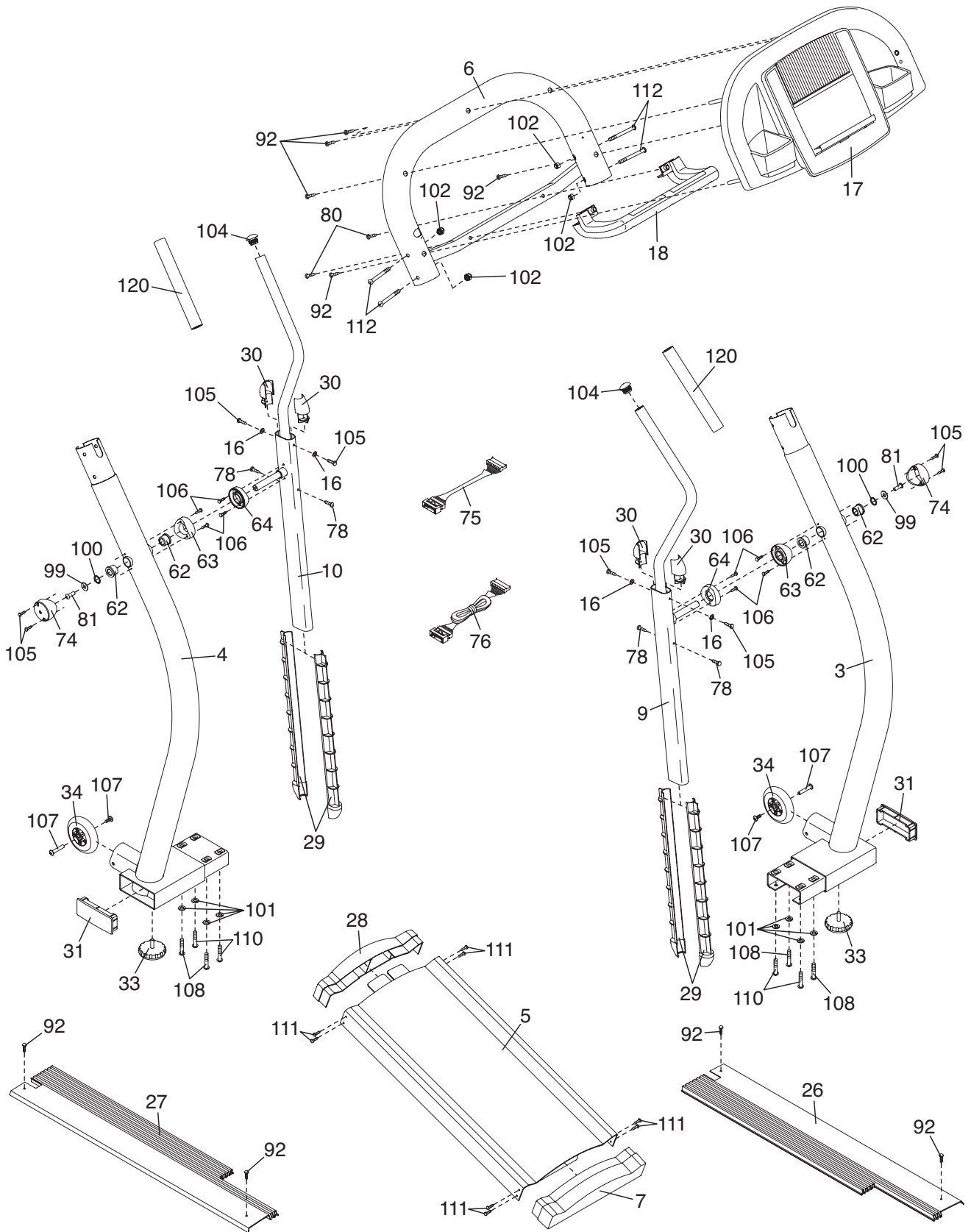

EXPLODED DRAWING B—Model No. PFEL09907.0

R0907A

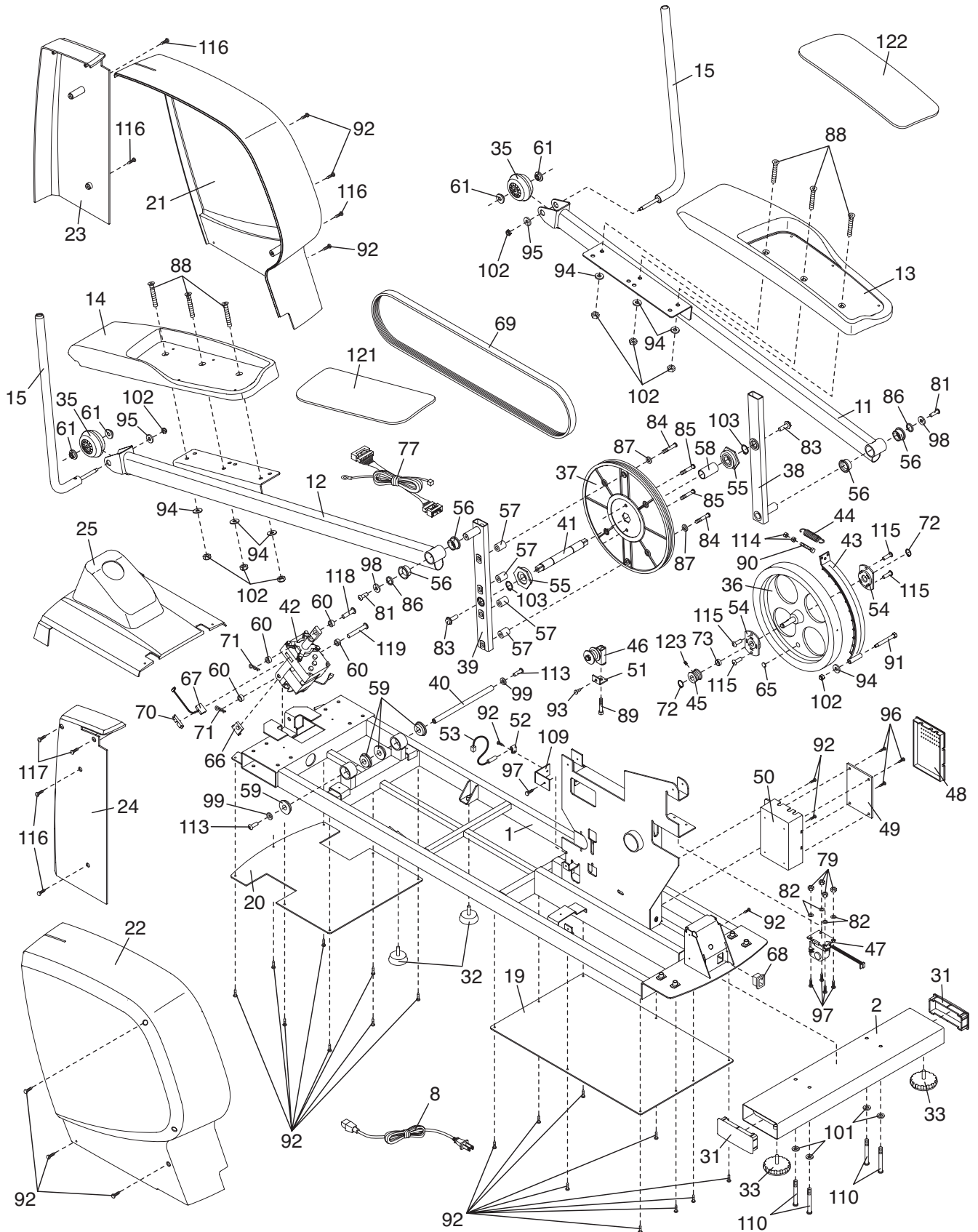

ORDERING REPLACEMENT PARTS

To order replacement parts, please see the front cover of this manual. To help us assist you, be prepared to provide the following information when contacting us:

- the model number and serial number of the product (see the front cover of this manual)
- the name of the product (see the front cover of this manual)
- the key number and description of the replacement part(s) (see the PART LIST and the EXPLODED DRAWING near the end of this manual)

LIMITED WARRANTY

ICON Health & Fitness, Inc. (ICON) warrants this product to be free from defects in workmanship and material, under normal use and service conditions, for a period of one (1) year from the date of purchase. This warranty extends only to the original purchaser. ICON's obligation under this warranty is limited to replacing or repairing, at ICON's option, the product through one of its authorized service centers. All repairs for which warranty claims are made must be pre-authorized by ICON. If the product is shipped to a service center, freight charges to and from the service center will be the customer's responsibility. For in-home service, the customer will be responsible for a minimal trip charge. This warranty does not extend to any product or damage to a product caused by or attributable to freight damage, abuse, misuse, improper or abnormal usage or repairs not provided by an ICON authorized service center; products used for commercial or rental purposes; or products used as store display models. No other warranty beyond that specifically set forth above is authorized by ICON.

ICON is not responsible or liable for indirect, special or consequential damages arising out of or in connection with the use or performance of the product or damages with respect to any economic loss, loss of property, loss of revenues or profits, loss of enjoyment or use, costs of removal or installation or other consequential damages of whatsoever nature. Some states do not allow the exclusion or limitation of incidental or consequential damages. Accordingly, the above limitation may not apply to you.

The warranty extended hereunder is in lieu of any and all other warranties and any implied warranties of merchantability or fitness for a particular purpose is limited in its scope and duration to the terms set forth herein. Some states do not allow limitations on how long an implied warranty lasts. Accordingly, the above limitation may not apply to you.

This warranty gives you specific legal rights. You may also have other rights which vary from state to state.

ICON HEALTH & FITNESS, INC., 1500 S. 1000 W., LOGAN, UT 84321-9813