

Robert Bosch GmbH
Power Tools Division
70745 Leinfelden-Echterdingen
Germany

www.bosch-pt.com

1 609 929 W91 (2010.05) T / 218 XXX



1 609 929 W91

GLL 2 Professional



- | | | |
|---|---|---------------------------------------|
| de Originalbetriebsanleitung | el Πρωτότυπο οδηγιών χρήσης | sr Originalno uputstvo za rad |
| en Original instructions | tr Orijinal işletme talimatı | sl Izvirna navodila |
| fr Notice originale | pl Instrukcja oryginalna | hr Originalne upute za rad |
| es Manual original | cs Původní návod k používání | et Algupärane kasutusjuhend |
| pt Manual original | sk Pôvodný návod na použitie | lv Instrukcijas oriģinālvalodā |
| it Istruzioni originali | hu Eredeti használati utasítás | lt Originali instrukcija |
| nl Oorspronkelijke
gebruiksaanwijzing | ru Оригинальное руководст-
во по эксплуатации | cn 正本使用说明书 |
| da Original brugsanvisning | uk Оригінальна інструкція з
експлуатації | |
| sv Bruksanvisning i original | ro Instrucțiuni originale | |
| no Original driftsinstruks | bg Оригинална инструкция | |
| fi Alkuperäiset ohjeet | | |



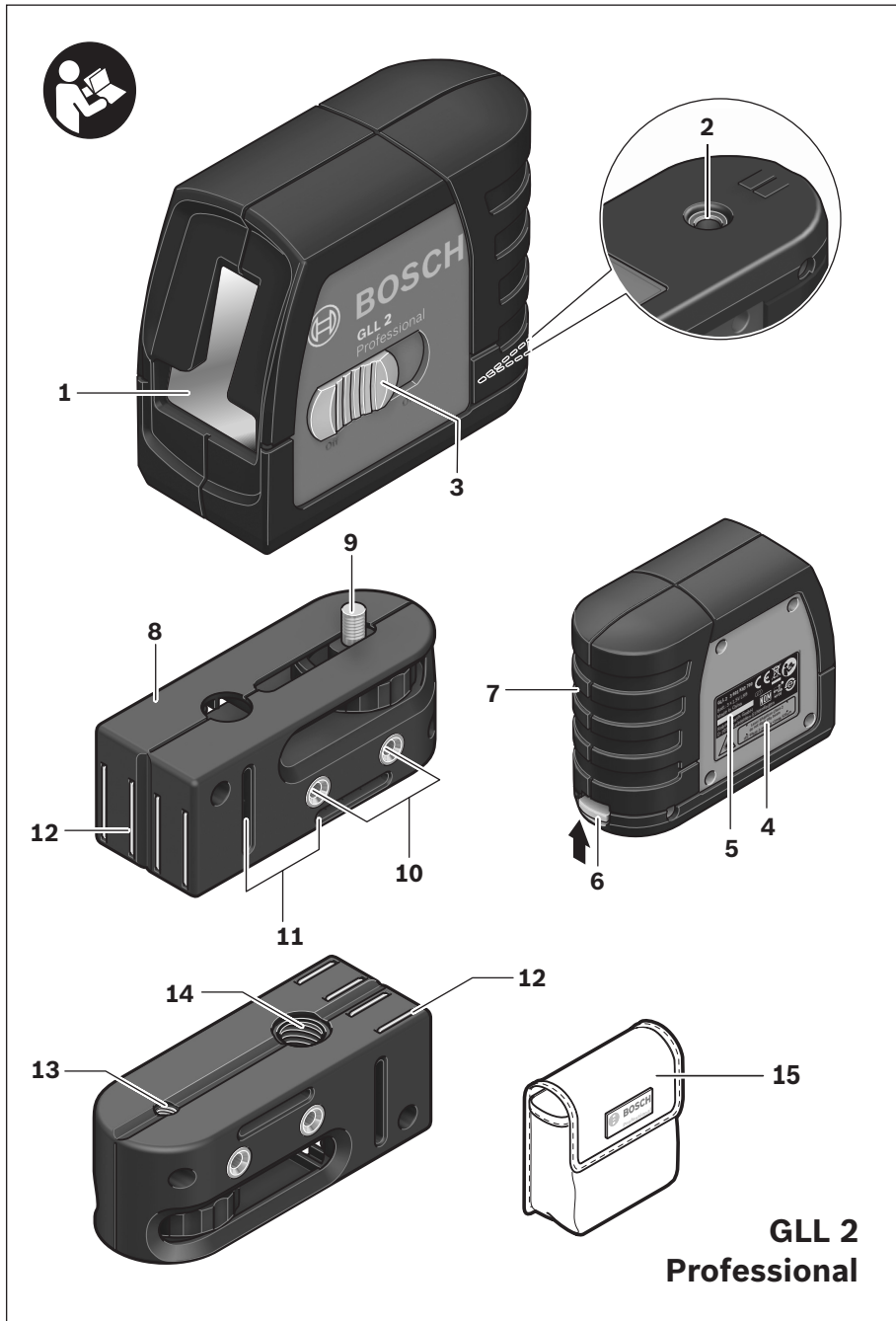

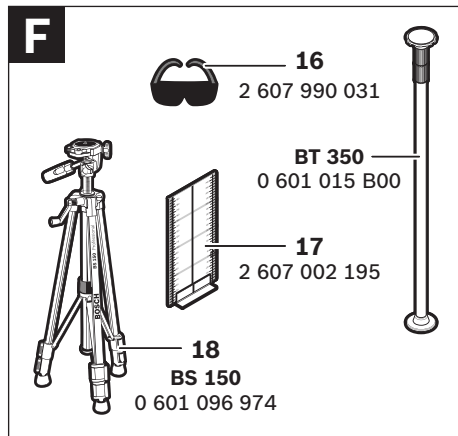
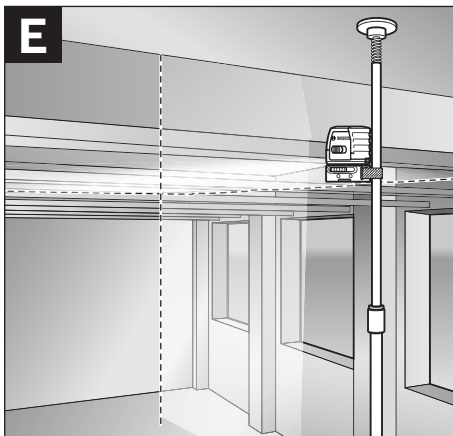
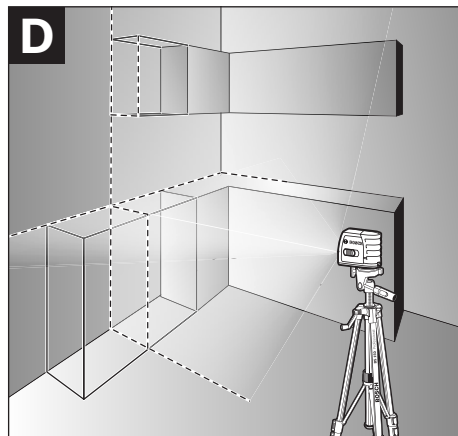
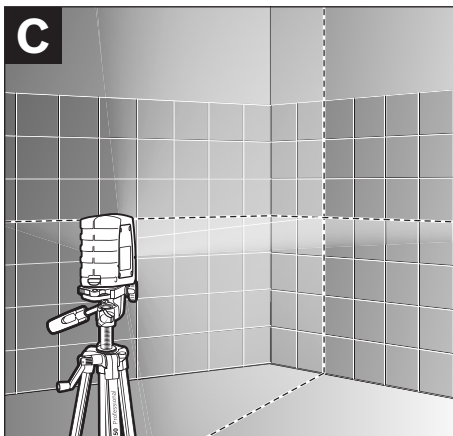
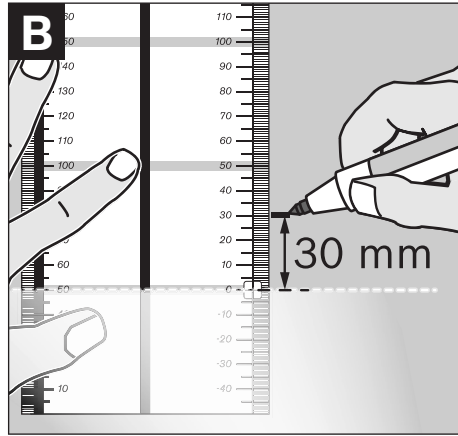
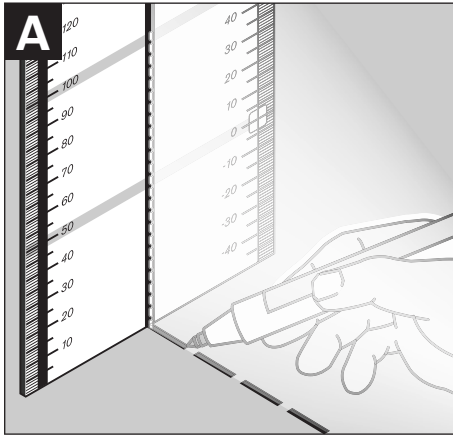

Safety Notes

Cross-line Laser



Working safely with the measuring tool is possible only when the operating and safety information are read completely and the instructions contained therein are strictly followed. Never make warning labels on the measuring tool unrecognisable. SAVE THESE INSTRUCTIONS.

- ▶ **Caution – The use of other operating or adjusting equipment or the application of other processing methods than those mentioned here, can lead to dangerous radiation exposure.**
- ▶ **The measuring tool is provided with a warning label in English (marked with number 4 in the representation of the measuring tool on the graphics page).**



- ▶ **Do not direct the laser beam at persons or animals and do not stare into the laser beam yourself.** This measuring tool produces laser class 2 laser radiation according to IEC 60825-1. This can lead to persons being blinded.
- ▶ **Do not use the laser viewing glasses as safety goggles.** The laser viewing glasses are used for improved visualisation of the laser beam, but they do not protect against laser radiation.
- ▶ **Do not use the laser viewing glasses as sun glasses or in traffic.** The laser viewing glasses do not afford complete UV protection and reduce colour perception.

- ▶ **Have the measuring tool repaired only through qualified specialists using original spare parts.** This ensures that the safety of the measuring tool is maintained.
- ▶ **Do not allow children to use the laser measuring tool without supervision.** They could unintentionally blind other persons or themselves.
- ▶ **Do not operate the measuring tool in explosive environments, such as in the presence of flammable liquids, gases or dusts.** Sparks can be created in the measuring tool which may ignite the dust or fumes.

Holder



Keep the holder 8 away from cardiac pacemakers. The magnets 12 generate a field that can impair the function of cardiac pacemakers.

- ▶ **Keep the holder 8 away from magnetic data medium and magnetically-sensitive equipment.** The effect of the magnets 12 can lead to irreversible data loss.

Functional Description

Please unfold the fold-out page with the representation of the measuring tool and leave it unfolded while reading the operating instructions.

Intended Use

The measuring tool is intended for determining and checking horizontal and vertical lines.

Technical Data

Cross-line Laser	GLL 2 Professional
Article number	3 601 K63 700
Working range, min. ¹⁾	10 m
Levelling Accuracy	±0.3 mm/m
Self-levelling range, typically	±4°
Levelling duration, typically	<4 s
Operating temperature	-10 °C ... +50 °C
Storage temperature	-20 °C ... +70 °C
Relative air humidity, max.	90 %
Laser class	2
Laser type	635 nm, <1 mW
C ₆	1
Tripod mount	
– Cross-line Laser	1/4"
– Holder	1/4"; 5/8"
Batteries	3 x 1.5 V LR06 (AA)
Operating life time, approx.	15 h
Automatic switch-off after approx.	30 min
Weight according to EPTA-Procedure 01/2003	0.25 kg
Dimensions	80 x 42 x 96 mm
Degree of protection	IP 5X (dust protected)

1) The working range can be decreased by unfavourable environmental conditions (e.g. direct sun irradiation).

Please observe the article number on the type plate of your measuring tool. The trade names of the individual measuring tools may vary.

The measuring tool can be clearly identified with the serial number **5** on the type plate.

Product Features

The numbering of the product features shown refers to the illustration of the measuring tool on the graphic page.

- 1 Exit opening for laser beam
- 2 Tripod mount 1/4"
- 3 On/Off switch
- 4 Laser warning label
- 5 Serial number
- 6 Latch of battery lid
- 7 Battery lid
- 8 Holder

- 9 Locking screw for holder
- 10 Screw holes of holder
- 11 Opening for strap attachment
- 12 Magnets
- 13 1/4" tripod mount on holder
- 14 5/8" tripod mount on holder
- 15 Protective pouch
- 16 Laser viewing glasses*
- 17 Measuring plate with stand*
- 18 Tripod*

* The accessories illustrated or described are not included as standard delivery.

Assembly

Inserting/Replacing the Battery

Alkali-manganese batteries are recommended for the measuring tool.

To open the battery lid **7**, press the latch of the battery lid **6** in the direction of the arrow and remove the battery lid. Insert the supplied batteries. When inserting, pay attention to the correct polarity according to the representation on the inside of the battery compartment.

When the batteries become weak, the laser beams flash rapidly for about 5 s (while the measuring tool is switched on).

Always replace all batteries at the same time. Only use batteries from one brand and with the identical capacity.

- ▶ **Remove the batteries from the measuring tool when not using it for extended periods.** When storing for extended periods, the batteries can corrode and discharge themselves.

Operation

Initial Operation

- ▶ **Protect the measuring tool against moisture and direct sun light.**
- ▶ **Do not subject the measuring tool to extreme temperatures or variations in temperature.** As an example, do not leave it in vehicles for longer periods. In case of large variations in temperature, allow the measuring tool to adjust to the ambient temperature before putting it into operation. In case of extreme temperatures or variations in temperature, the accuracy of the measuring tool can be impaired.
- ▶ **Avoid heavy impact or falling of the measuring tool.** After heavy exterior impact on the measuring tool, an accuracy check should always be carried out before continuing to work (see "Levelling Accuracy").
- ▶ **Switch the measuring tool off during transport.** When switching off, the levelling unit, which can be damaged in case of intense movement, is locked.

Switching On and Off

To **switch on** the measuring tool, push the On/Off switch **3** to the "On" position. Immediately after switching on, the measuring tool sends two laser beams out of the exit opening **1**.

- ▶ **Do not point the laser beam at persons or animals and do not look into the laser beam yourself, not even from a large distance.**

To **switch off** the measuring tool, slide the On/Off switch **3** to the "Off" position. When switching off, the levelling unit is locked.

- ▶ **Do not leave the switched on measuring tool unattended and switch the measuring tool off after use.** Other persons could be blinded by the laser beam.

The measuring tool switches off automatically after an operating duration of 30 minutes.

Working with Automatic Levelling

Position the measuring tool on a level and firm support, attach it to the holder **8** or to the tripod **18**.

After switching on, the levelling function automatically compensates irregularities within the self-levelling range of $\pm 4^\circ$. The levelling is finished as soon as the laser beams do not move any more.

If the automatic levelling function is not possible, e.g. because the surface on which the measuring tool stands deviates by more than 4° from the horizontal plane, the laser beams flash slowly. In this case, bring the measuring tool to the level position and wait for the self-levelling to take place. As soon as the measuring tool is within the self-levelling range of $\pm 4^\circ$, the laser lines light up continuously again.

In case of ground vibrations or position changes during operation, the measuring tool is automatically levelled in again. To avoid errors, check the position of the horizontal and vertical laser line with regard to the reference points upon re-levelling.

Levelling Accuracy

Influences on Accuracy

The ambient temperature has the greatest influence. Especially temperature differences occurring from the ground upward can divert the laser beam.

As thermal fluctuation is largest close to the ground, the measuring tool, if possible, should be mounted on a commercially available tripod and placed in the centre of the working area.

Apart from exterior influences, device-specific influences (such as heavy impact or falling down) can lead to deviations. Therefore, check the accuracy of the measuring tool each time before starting your work.

First, check both the height as well as the levelling accuracy of the horizontal laser line, then the levelling accuracy of the vertical laser line.

Should the measuring tool exceed the maximum deviation during one of the tests, please have it repaired by a Bosch after-sales service.

Checking the Height Accuracy of the Horizontal Line

For this check, a free measuring distance of 5 metres on a firm surface between two walls A and B is required.

- Mount the measuring tool onto the holder or a tripod, or place it on a firm and level surface close to wall A. Switch the measuring tool on.

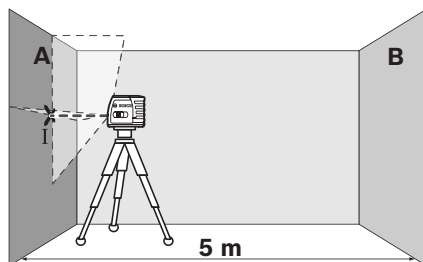

- Direct the laser against the close wall A and allow the measuring tool to level in. Mark the centre of the point where the laser lines cross each other on the wall (point I).

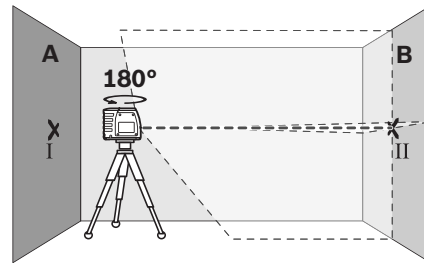

- Turn the measuring tool by 180°, allow it to level in and mark the cross point of the laser lines on the opposite wall B (point II).
- Without turning the measuring tool, position it close to wall B. Switch the measuring tool on and allow it to level in.

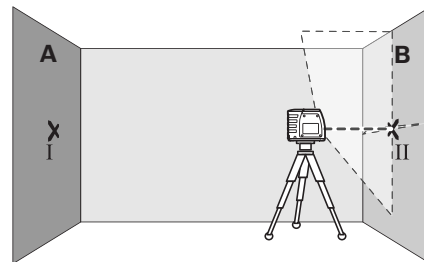

- Align the height of the measuring tool (using a tripod or by underlaying, if required) in such a manner that the cross point of the laser lines is projected against the previously marked point II on the wall B.

18 | English

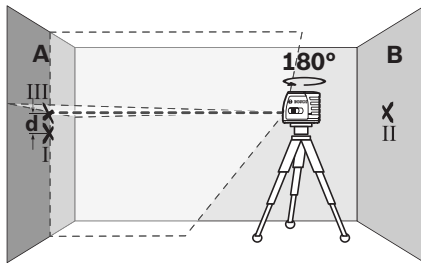

- Without changing the height, turn around the measuring tool by 180°. Direct it against the wall A in such a manner that the vertical laser line runs through the already marked point I. Allow the measuring tool to level in and mark the cross point of the laser lines on the wall A (point III).
- The difference **d** of both marked points I and III on wall A indicates the actual height deviation of the measuring tool.

The maximum permitted deviation d_{\max} is calculated as follows:

$d_{\max} = \text{double distance of the walls} \times 0.3 \text{ mm/m}$
 Example: With a 5 metre distance between the walls, the maximum deviation must not exceed $d_{\max} = 2 \times 5 \text{ m} \times 0.3 \text{ mm/m} = 3 \text{ mm}$. Thus, the marks must not be more than 3 mm apart.

Checking the Levelling Accuracy of the Horizontal Line

For the check, a free surface of approx. 5 x 5 metres is required.

- Mount the measuring tool between both walls A and B onto the holder or a tripod, or place it on a firm and level surface. Allow the measuring tool to level in.

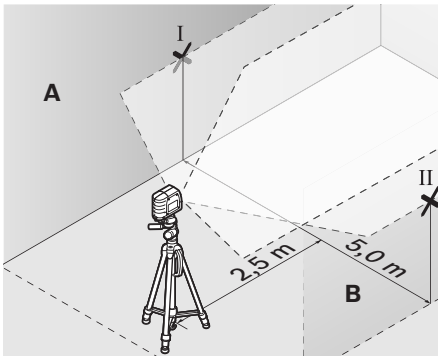

- At a distance of 2.5 metres from the measuring tool, mark the centre of the laser line (point I on wall A and point II on wall B) on both walls.

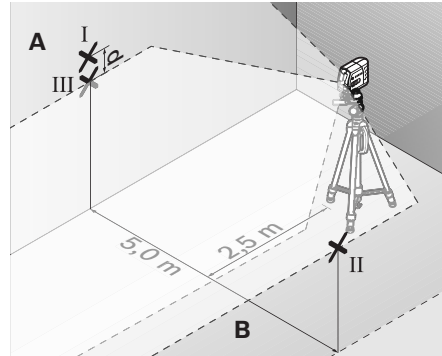

- Set up the measuring tool 5 metres away turned by 180° and allow it to level in.
- Align the height of the measuring tool (using a tripod or by underlaying, if required) in such a manner that the centre of the laser line is projected exactly against the previously marked point II on wall B.
- Mark the centre of the laser line as point III (vertically above or below point I) on the wall A.
- The difference **d** of both marked points I and III on wall A indicates the actual deviation of the measuring tool from the level plane.

The maximum permitted deviation d_{\max} is calculated as follows:

$d_{\max} = \text{double distance of the walls} \times 0.3 \text{ mm/m}$
 Example: With a 5 metre distance between the walls, the maximum deviation must not exceed $d_{\max} = 2 \times 5 \text{ m} \times 0.3 \text{ mm/m} = 3 \text{ mm}$. Thus, the marks must not be more than 3 mm apart.

Checking the Levelling Accuracy of the Vertical Line

For this check, a door opening is required with at least 2.5 metres of space (on a firm surface) to each side of the door.

- Position the measuring tool on a firm, level surface (not on a tripod) 2.5 m away from the door opening. Direct the laser beams at the door opening and allow the measuring tool to level in.

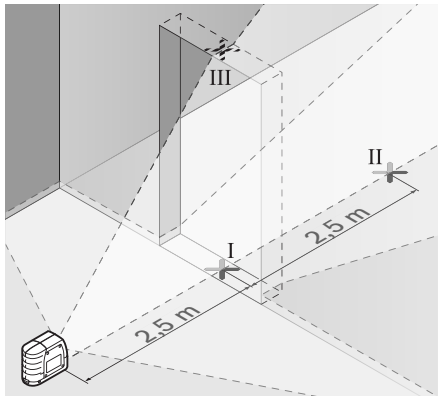

- Mark the centre of the vertical laser line at the floor of the door opening (point I), at a distance of 5 metres beyond the other side of the door opening (point II) and at the upper edge of the door opening (point III).

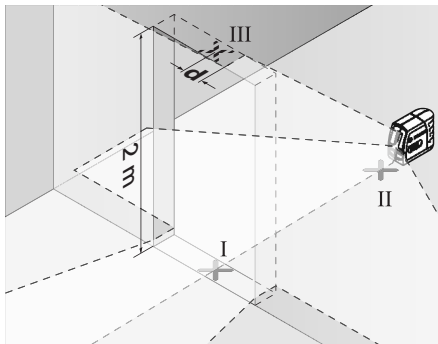

- Position the measuring tool on the other side of the door opening directly behind point II. Allow the measuring tool to level in and align the vertical laser line in such a manner that its centre runs exactly through points I and II.

- The difference **d** between point III and the centre of the laser line at the upper edge of the door opening results in the actual deviation of the measuring tool from the vertical plane.
- Measure the height of the door opening.

The maximum permitted deviation d_{\max} is calculated as follows:

$$d_{\max} = \text{double height of the door opening} \times 0.3 \text{ mm/m}$$

Example: With a door opening height of 2 metres, the maximum permitted deviation is $d_{\max} = 2 \times 2 \text{ m} \times 0.3 \text{ mm/m} = 1.2 \text{ mm}$. Thus, the marks must not be more than 1.2 mm apart.

Working Advice

- Always use the centre of the laser line for marking.** The width of the laser line changes with the distance.

Attaching with the Holder

To fasten the measuring tool on the holder **8**, screw the locking screw **9** of the holder into the 1/4" tripod mount **2** on the measuring tool and tighten. To rotate the measuring tool on the holder, slightly loosen the screw **9**.

With the holder **8**, the measuring tool can be attached as follows:

- Mount the holder **8** to the tripod **18** or a commercially available camera tripod via the 1/4" tripod mount **13**. For fastening to a commercially available construction tripod, use the 5/8" tripod mount **14**.
- The holder **8** can be fastened to steel parts via the magnets **12**.
- The holder **8** can be fastened to drywalls or wood walls with screws. For this, insert screws with a minimum length of 50 mm into the screw holes **10** of the holder.
- The holder **8** can also be fastened to pipes or similar beams using a commercially available strap by threading it through the opening **11** for strap attachment.

Working with the Tripod (Accessory)

A tripod offers a stable, height-adjustable measuring support. Place the measuring tool via the tripod mount **2** onto the 1/4" male thread of the tripod and screw the locking screw of the tripod tight.

**Working with the Measuring Plate (Accessory)
(see figures A–B)**

With the measuring plate **17**, it is possible to project the laser mark onto the floor or the laser height onto a wall.

With the zero field and the scale, the offset or drop to the required height can be measured and projected at another location. This eliminates the necessity of precisely adjusting the measuring tool to the height to be projected.

The measuring plate **17** has a reflective coating that enhances the visibility of the laser beam at greater distances or in intense sunlight. The brightness intensification can be seen only when viewing, parallel to the laser beam, onto the measuring plate.

Laser Viewing Glasses (Accessory)

The laser viewing glasses filter out the ambient light. This makes the red light of the laser appear brighter for the eyes.

- ▶ **Do not use the laser viewing glasses as safety goggles.** The laser viewing glasses are used for improved visualisation of the laser beam, but they do not protect against laser radiation.
- ▶ **Do not use the laser viewing glasses as sun glasses or in traffic.** The laser viewing glasses do not afford complete UV protection and reduce colour perception.

Work Examples (see figures C–E)

Applicational examples for the measuring tool can be found on the graphics pages.

Maintenance and Service

Maintenance and Cleaning

Store and transport the measuring tool only in the supplied protective pouch.

Keep the measuring tool clean at all times.

Do not immerse the measuring tool in water or other fluids.

Wipe off debris using a moist and soft cloth. Do not use any cleaning agents or solvents.

Regularly clean the surfaces at the exit opening of the laser in particular, and pay attention to any fluff of fibres.

If the measuring tool should fail despite the care taken in manufacturing and testing procedures, repair should be carried out by an authorised after-sales service centre for Bosch power tools. Do not open the measuring tool yourself.

In all correspondence and spare parts orders, please always include the 10-digit article number given on the type plate of the measuring tool.

In case of repairs, send in the measuring tool packed in its protective pouch **15**.

After-sales Service and Customer Assistance

Our after-sales service responds to your questions concerning maintenance and repair of your product as well as spare parts. Exploded views and information on spare parts can also be found under:

www.bosch-pt.com

Our customer service representatives can answer your questions concerning possible applications and adjustment of products and accessories.

Great Britain

Robert Bosch Ltd. (B.S.C.)
P.O. Box 98
Broadwater Park
North Orbital Road
Denham
Uxbridge
UB 9 5HJ
Tel. Service: +44 (0844) 736 0109
Fax: +44 (0844) 736 0146
E-Mail: boschservicecentre@bosch.com

Ireland

Origo Ltd.
Unit 23 Magna Drive
Magna Business Park
City West
Dublin 24
Tel. Service: +353 (01) 4 66 67 00
Fax: +353 (01) 4 66 68 88

Australia, New Zealand and Pacific Islands

Robert Bosch Australia Pty. Ltd.
 Power Tools
 Locked Bag 66
 Clayton South VIC 3169
 Customer Contact Center
 Inside Australia:
 Phone: +61 (01300) 307 044
 Fax: +61 (01300) 307 045
 Inside New Zealand:
 Phone: +64 (0800) 543 353
 Fax: +64 (0800) 428 570
 Outside AU and NZ:
 Phone: +61 (03) 9541 5555
 www.bosch.com.au

Republic of South Africa**Customer service**

Hotline: +27 (011) 6 51 96 00

Gauteng – BSC Service Centre

35 Roper Street, New Centre
 Johannesburg
 Tel.: +27 (011) 4 93 93 75
 Fax: +27 (011) 4 93 01 26
 E-Mail: bsctools@icon.co.za

KZN – BSC Service Centre

Unit E, Almar Centre
 143 Crompton Street
 Pinetown
 Tel.: +27 (031) 7 01 21 20
 Fax: +27 (031) 7 01 24 46
 E-Mail: bsc.dur@za.bosch.com

Western Cape – BSC Service Centre

Democracy Way, Prosperity Park
 Milnerton
 Tel.: +27 (021) 5 51 25 77
 Fax: +27 (021) 5 51 32 23
 E-Mail: bsc@zsd.co.za

Bosch Headquarters

Midrand, Gauteng
 Tel.: +27 (011) 6 51 96 00
 Fax: +27 (011) 6 51 98 80
 E-Mail: rbsa-hq.pts@za.bosch.com

People's Republic of China

Website: www.bosch-pt.com.cn

China Mainland

Bosch Power Tools (China) Co., Ltd.
 567, Bin Kang Road
 Bin Jiang District 310052
 Hangzhou, P.R.China
 Service Hotline: 800 8 20 84 84
 Tel.: +86 (571) 87 77 43 38
 Fax: +86 (571) 87 77 45 02

HK and Macau Special Administrative Regions

Robert Bosch Hong Kong Co. Ltd.
 21st Floor, 625 King's Road
 North Point, Hong Kong
 Customer Service Hotline: +852 (21) 02 02 35
 Fax: +852 (25) 90 97 62
 E-Mail: info@hk.bosch.com
 www.bosch-pt.com.cn

Indonesia

PT. Multi Tehaka
 Kawasan Industri Pulogadung
 Jalan Rawa Gelam III No. 2
 Jakarta 13930
 Indonesia
 Tel.: +62 (21) 46 83 25 22
 Fax: +62 (21) 46 82 86 45/68 23
 E-Mail: sales@multitehaka.co.id
 www.multitehaka.co.id

Philippines

Robert Bosch, Inc.
 28th Floor Fort Legend Towers,
 3rd Avenue corner 31st Street,
 Fort Bonifacio Global City,
 1634 Taguig City, Philippines
 Tel.: +63 (2) 870 3871
 Fax: +63 (2) 870 3870
 matheus.contiero@ph.bosch.com
 www.bosch-pt.com.ph
 Bosch Service Center:
 9725-27 Kamagong Street
 San Antonio Village
 Makati City, Philippines
 Tel.: +63 (2) 899 9091
 Fax: +63 (2) 897 6432
 rosalie.dagdagan@ph.bosch.com

Malaysia

Robert Bosch (S.E.A.) Pte. Ltd.
 No. 8A, Jalan 13/6
 G.P.O. Box 10818
 46200 Petaling Jaya
 Selangor, Malaysia
 Tel.: +60 (3) 7966 3194
 Fax: +60 (3) 7958 3838
 cheehoe.on@my.bosch.com
 Toll-Free: 1800 880 188
 www.bosch-pt.com.my

Thailand

Robert Bosch Ltd.
 Liberty Square Building
 No. 287, 11 Floor
 Silom Road, Bangrak
 Bangkok 10500
 Tel.: +66 (2) 6 31 18 79 – 18 88 (10 lines)
 Fax: +66 (2) 2 38 47 83
 Robert Bosch Ltd., P. O. Box 2054
 Bangkok 10501, Thailand
 Bosch Service – Training Centre
 2869-2869/1 Soi Ban Kluay
 Rama IV Road (near old Paknam Railway)
 Prakanong District
 10110 Bangkok
 Thailand
 Tel.: +66 (2) 6 71 78 00 – 4
 Fax: +66 (2) 2 49 42 96
 Fax: +66 (2) 2 49 52 99

Singapore

Robert Bosch (SEA) Pte. Ltd.
 11 Bishan Street 21
 Singapore 573943
 Tel.: +65 6571 2772
 Fax: +65 6350 5315
 leongheng.leow@sg.bosch.com
 Toll-Free: 1800 333 8333
 www.bosch-pt.com.sg

Vietnam

Robert Bosch Vietnam Co. Ltd
 10/F, 194 Golden Building
 473 Dien Bien Phu Street
 Ward 25, Binh Thanh District
 84 Ho Chi Minh City
 Vietnam
 Tel.: +84 (8) 6258 3690 ext. 413
 Fax: +84 (8) 6258 3692
 hieu.lagia@vn.bosch.com
 www.bosch-pt.com

Disposal

Measuring tools, accessories and packaging should be sorted for environmental-friendly recycling.

Only for EC countries:

Do not dispose of measuring tools into household waste!
 According to the European Guideline 2002/96/EC for Waste Electrical and Electronic Equipment and its implementation into national

right, measuring tools that are no longer usable must be collected separately and disposed of in an environmentally correct manner.

Battery packs/batteries:

Do not dispose of battery packs/batteries into household waste, fire or water. Battery packs/batteries should, if possible, be discharged, collected, recycled or disposed of in an environmental-friendly manner.

Only for EC countries:

Defective or dead out battery packs/batteries must be recycled according to the guideline 2006/66/EC.

Batteries no longer suitable for use can be directly returned at:

Great Britain

Robert Bosch Ltd. (B.S.C.)
 P.O. Box 98
 Broadwater Park
 North Orbital Road
 Denham
 Uxbridge
 UB 9 5HJ
 Tel. Service: +44 (0844) 736 0109
 Fax: +44 (0844) 736 0146
 E-Mail: boschservicecentre@bosch.com

Subject to change without notice.