

### Overview

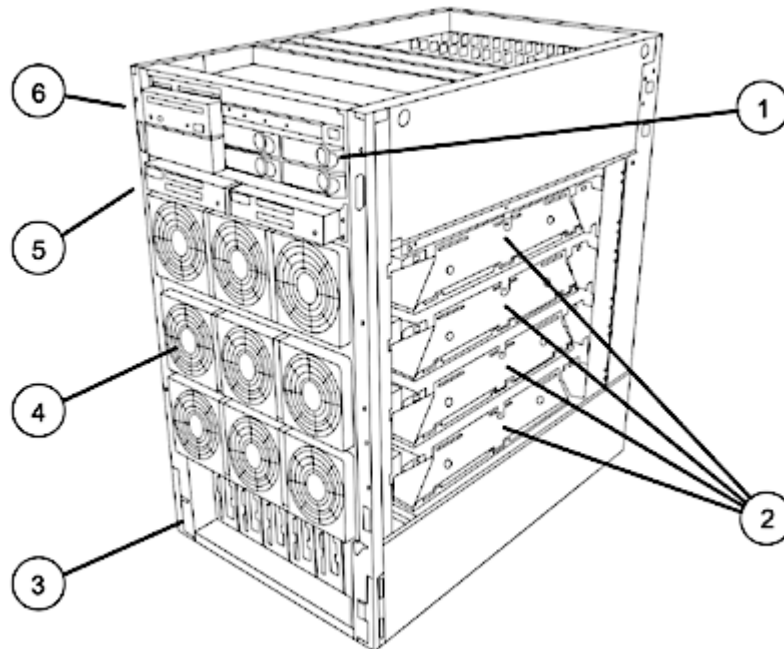

- |                             |                            |
|-----------------------------|----------------------------|
| 1. Hot-plug Disks           | 4. Redundant Hot-swap Fans |
| 2. Cell Boards              | 5. PCI Power Supplies      |
| 3. Redundant Hot-swap Power | 6. Removable Media DVD/DAT |

### Overview

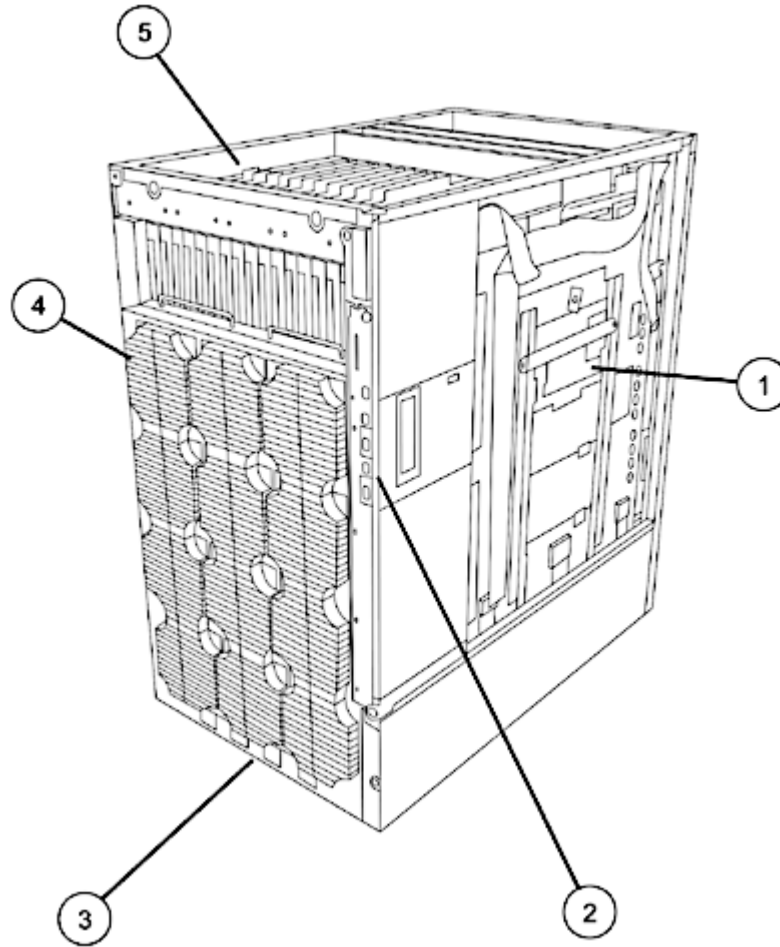

- 1. System Backplane
- 2. Core I/O
- 3. 2N Redundant Power Inputs
- 4. Hot-swap Redundant Fans
- 5. Hot-plug PCI Slots

### HP 9000 rp8440 Server Flexible Advantage Starter (FAST) Base Systems

The Flexible Advantage **ST**arter base systems for the HP 9000 rp8440 Server allow for faster configurations due to the semi configured base system bundles. Configurations built from FAST base systems will have substantially lower prices than systems built from the parts

Product Number*	Number of Processor cores	Number of Cell Boards	Number of core I/O Cards	Number of Power Supplies
AD031A	4	1	1	3
AD032A	8	1	1	3
AD033A	16	2	1	4
AD034A	24	3	1	5
AD035A	32	4	1	6

\*NOTE: Includes base chassis and power supplies

### Standard Features

---

#### Minimum System

- Two HP PA RISC PA 8900 (1P/2C) processors
  - One processor per cell board (Dual core PA 8900 requires one active core per cell board)
  - One cell board
  - 2GB memory (1 pair of 1 GB DIMMs)
  - One core I/O
  - One internal DVD drive for OpenVMS and Windows
  - Two power cords
  - 8 hot plug 33 /66 /133 /266 MHz 64 bit PCI X slots with adaptive signaling technology
- 

#### Maximum Server Capacities

- Sixteen HP PA RISC PA 8900 (16P/32C) processors
- Four processors per cell board
- Four cell boards
- 256GB memory (32 pairs of 4GB DIMMs)
- Four power cords, providing 2N power and dual grid support
- Four internal hot plug LVD SCSI disks
- Two removable media drives-DVD or DAT
- Sixteen PCI expansion cards

Maximum capacities when configured with the Server Expansion Unit 2 (SEU 2):

- Four core I/O cards
  - Eight internal hot plug LVD SCSI disks
  - Four removable media drives-DVD or DAT
  - 32 hot plug 33 /66 /133 /266 MHz 64 bit PCI X slots with adaptive signaling technology
- 

#### Standard System Features

- Operating system support: HP UX 11i v1, HP UX 11i v2 and HP UX 11i v3
  - External Ultra320 SCSI channel
  - Two Internal Ultra320 SCSI channels, one channel to each internal disk
  - 1 GbE LAN ports
  - Management Processor technology with Integrated LAN console
  - Rackmountable into HP 19 inch cabinets (factory or field integration)
  - Rackmountable into some 3rd party cabinets
  - Two hardware partitions (nPartitions)
  - Four hardware partitions when configured with the Server Expansion Unit
  - Factory integration of processors, memory, disk drives, removable media drives, and I/O cards
  - HP site planning and installation
  - One year warranty with same business day on site service response
  - Owner's Guide and General Usage media set
-

### Standard Features

#### High Availability

- N+1 Hot swap cooling
- Redundant and hot swap power supplies
- Cell Hot plug
- Hot plug disks
- 2N power inputs
- On line memory page deallocation
- ECC protected DDR II memory
- Full parity protection of data and address buses
- On chip processor cache with ECC protection
- Memory "chip spare", "chip kill" like (Double Chip Spare to be added 3 months after launch)
- Dynamic Processor resilience and deallocation (processor deallocation on failure)
- On line addition and replacement of PCI I/O cards
- UPS power management
- Management Processor Failover (requires server to have two MP installed)
- Four independent UltraSCSI buses to internal disks for mirroring across disks and controllers
- Journal file system (HP UX)
- Auto reboot
- On line diagnostics and system health monitor

---

#### Security

- Separate console LAN port for system management
- Password protection on console port
- Disablement of remote console ports

---

#### Internet Server Functions

- Internet server (inetd)
- Domain name server
- Routing (OSPF, BIND, RIP, EGP, HELLO, gated)
- Network Time Protocol

---

#### Client Configuration Services

- Automatic configuration for printers, PCs, workstations, and X terminals (DHCP, Bootp, tftp, rbootp)

---

#### Optional Web Services

- Netscape Communication Server
- Netscape Navigator

---

#### Email

- Mail, MailX, ELM
- Sendmail, MIME, SMTP, ESMTP

---

#### Remote Access Services

- Telnet, ftp, anonymous ftp server

### Configuration

#### Configuration

The HP 9000 rp8440 Server is a symmetrical multiprocessing (SMP) server supporting up to 16 high performance dual core HP PA RISC PA 8900 (1.068 GHz/64 MB L3 cache). The server is based on the new and improved sx2000 chip set. The rp8440 can be configured as a single SMP server or divided into up to four smaller, hardware partitioned (nPars), logical servers.

#### Cell Boards

A minimum of one and a maximum of four cells can be ordered in HP 9000 rp8440 Servers. Each cell can be purchased with up to four active PA 8900 processors, or in combination with Instant Capacity processors.

The HP 9000 rp8440 and HP 9000 rp7440 (8 processor) servers share the same cell board. The rp8400/rp8420/rx8620 cell boards cannot be carried forward to the rp8440 server.

Note that the rp8440 and rp7440 cell boards can be carried forward to the rx7640 and rx8640 Servers.

#### Cell Details

- 4 processor slots (supporting up to eight processor cores with dual core)
- HP sx2000 cell controller
- 16 DDR 2 Memory DIMM slots
- DC DC Power converters
- Manageability and Processor Dependent Hardware Circuitry

#### Cell Board Configuration Rules

- Cell boards are ordered individually
- Minimum: 1 cell board; Maximum: 4 cell boards
- Cell slots 0 or 1 must be loaded first
- Recommended Cell board loading order: 0, 1, 2, 3

#### HP PA RISC PA 8900 Processor Details

- 1.068 GHz
- Level 2 cache: 64 MB
- Level 1 cache: .0.75 MB instr + 0.75 MB data per core (3 MB total)
- 44 bit physical addressing
- 64 bit virtual addressing
- 4 GB maximum page size

#### Processor Configuration Rules

- The HP PA RISC PA 8900 processors have two processors core per processor module.
- There must be at least one active processors core (non iCAP) on each active cell board.
- Activation of iCAP processors cores can be done one core at a time customers may order and upgrade the PA 8900 processor in increments of at least one core (in this case the other core in a processor must be iCAP).
- On each cell board, processors must be installed in the following sequence 0, 2, 1, 3

### Configuration

**Memory Configuration** The memory DIMMs used in the HP 9000 rp8440 Server are sold in pairs and are custom designed by HP. Each DIMM contains DDR II memory chips qualified to run at 267/533 MHz, with full ECC protection. DIMM sizes of 1 GB and 2 GB are supported. HP 9000 rp8400/rp8420/rx8620 memory modules cannot be carried forward to the rp8440 server. Each HP 9000 rp8440 Server cell board supports up to 16 DIMM slots and 17 GB/s of peak memory bandwidth.

#### HP 9000 rp8440 Memory DIMMs

Pair Size (Product)	rp8440 Product Number	HP 9000 rp8440 Server Maximum Capacity Using 1 DIMM Size	DIMM Size
2 GB	AB453A	16 GB	1024 MB
4 GB	AB454A	128 GB	2048 MB
8 GB	AB455A	256 GB	4096 MB

#### Memory Loading Rules

- Memory must be installed in pairs (2 DIMMs of equal density)
- DIMM pairs must be loaded in slot order
- Memory is available in three densities: 2 GB (2×1024MB), 4 GB (2×2048MB) and 8 GB (2×4096MB)
- Minimum memory is 2 GB per cell
- Maximum memory per system is 256 GB-using 32 4GB pairs per system
- Larger DIMMs must be loaded first across a cell, followed by progressively smaller DIMM sizes.
- On each cell board, Memory pairs must be installed in the following order: (0A, 0B), (1A, 1B), (2A, 2B), (3A, 3B), (4A, 4B), (5A, 5B), (6A, 6B), (7A, 7B)
- DIMM mixing other than recommended configurations is supported as long as the memory loading rules are followed

#### rp8440 Recommended Memory Configurations

Memory per Cell (GBs)	Number of DIMMs			Quad Echelon							
	1 GB	2 GB	4 GB	2	1	3	0	2	1	3	0
				0A, 0B	1A, 1B	2A, 2B	3A, 3B	4A, 4B	5A, 5B	6A, 6B	7A, 7B
2	2			1 GB							
4	4			1 GB	1 GB						
8	6			1 GB	1 GB	1 GB	1 GB				
16	16			1 GB	1 GB	1 GB	1 GB	1 GB	1 GB	1 GB	1 GB
24	8	8		2 GB	2 GB	2 GB	2 GB	1 GB	1 GB	1 GB	1 GB
32		16		2 GB	2 GB	2 GB	2 GB	2 GB	2 GB	2 GB	2 GB
48		8	8	4 GB	4 GB	4 GB	4 GB	2 GB	2 GB	2 GB	2 GB
64			16	4 GB	4 GB	4 GB	4 GB	4 GB	4 GB	4 GB	4 GB

### Configuration

#### Performance Tuning Guidelines

- For best performance, a cell should be configured with a multiple of 8 DIMMs or four pairs (although the server will execute properly with an odd number of pairs). It takes 8 DIMMs to populate both memory buses. Populating only one of the two memory buses on a cell board will deliver only half the peak memory bandwidth.
- Load memory equally across the available cell boards.

#### Memory Latencies

There are two types of memory latencies within the HP 9000 rp8440 Server:

1. Memory latency within the cell refers to the case where an application either runs on a partition that consists of a single cell or uses cell local memory.
2. Memory latency between cell refers to the case where the partition consists of two or more cell and cell interleaved memory is used. For example, for an rp8440 server with four cells in the partition, 25% of the addresses are to memory on the same cell as the requesting processor, and the other 75% of the addresses are to memory on the other three cells.

The HP 9000 rp8440 Server memory latency depends on the number of processors in the partition. Assuming that memory accesses are equally distributed across all cell boards and memory controllers within the partition, the average idle memory latency (load to use) is as shown below:

Number of processor modules	Average Memory Latency
4-processor	185 ns
8-processor	249 ns
16-processor	334 ns

#### I/O Architecture

Components within the I/O subsystem are the I/O controllers, internal peripheral bay, and multifunction Core I/O. The figure below shows the basic block diagram of the I/O subsystem. The Integrity I/O architecture utilizes industry standard PCI buses in a unique design for maximum performance, scalability and reliability.

The HP 9000 rp8440 Server contains two master I/O controller chips located on the PCI X backplane. Each I/O controller contains sixteen high performance 12 bit wide links, which connect to sixteen slave I/O controller chips supporting the PCI X card slots and core I/O. Two links, one from each master controller is routed through the crossbar backplane and is dedicated to core I/O. The remaining thirty links are divided among the sixteen I/O card slots. This one card per link architecture leads to greater I/O performance and higher availability. Each controller chip is also directly linked to a host cell board. This means that at least two cell boards, located in cell slots 0 and 1, must be purchased in order to access all sixteen I/O card slots. With one cell board, access to eight slots is enabled.

The HP 9000 rp8440 Server can be purchased with either one or two core I/O boards (if an SEU 2 is added, then four core I/O boards with two core I/O in the SEU 2). Both core I/O boards are identical and provide console, SCSI, serial, and Management Processor (MP) functionality. The second core I/O is used to enable the dual hard partitioning in the HP 9000 rp8440 Server and provide access to a second set of disk drives.

The internal peripheral bay is divided into two identical halves. Each half supports up to two low profile disks and one removable media device. A SCSI controller chip located on each core I/O board supports each half of the internal peripheral bay. This means that both core I/O boards must be purchased to access both halves of the peripheral bay.

### Configuration

#### PCI Backplane

Eight of sixteen I/O card slots are supported by dual high performance fat links. Each link is capable of providing 1060 MB/s of bandwidth. This means that half HP 9000 rp8440 Server I/O slots are capable of sustained 2.12 GB/s. Six of the sixteen I/O card slots are supported at 1060 MB/s of bandwidth. Aggregate I/O slot bandwidth is approximately 23 GB/s. In addition, because each I/O slot has a dedicated bus, any slot can be "hot plugged" or serviced without affecting other slots. The hot plug operation is very easy, and can be done with minimal training and effort.

The HP 9000 rp8440 Server supports a number of PCI and PCI X HBA (I/O) cards for I/O expansion. **NOTE:** The PCI X backplane is backward compatible with the older PCI backplane and can support many PCI HBA (I/O) cards.

When HP 9000 rp8400 servers are upgraded to HP 9000 rp8440 servers using the chassis upgrade kit, the older and slower PCI backplanes in the HP 9000 rp8400 server must be upgraded to the newer and faster PCI X backplanes (AB314A) of the HP 9000 rp8440 Server.

When the rp8440 Server Expansion Unit 2 is connected to the HP 9000 rp8440 Server, its I/O backplanes act as PCI X I/O backplanes. See the rp8440 Server Expansion Unit 2 section for more details.

#### Supported HP-UX I/O Cards

I/O Card	Product Number	First HP-UX Release / Boot Support	Connector Type(s)	Hot Plug / Factory Integration	Maximum Cards/Ports
<b>Mass Storage Host Bus Adapters</b>					
PCI 1-port 2x Fibre Channel	A5158A	11.00/No	Duplex SC	Yes / No	16 / 16
PCI 2-Gb Fibre Channel	A6795A	11.00/Yes	LC	Yes / Yes	16 / 16
PCI 1-port 4-GB Fibre Channel	AB378A	11i/Yes	LC	Yes / Yes	16 / 16
PCI 2-port 4-GB Fibre Channel	AB379B	11i/Yes	LC	Yes / No	16 / 32
Dual channel Ultra320 SCSI Adapter	A7173A	11i/Yes	VHDCI	Yes / Yes	16 / 32
PCI-X 2 channel 2 GB/s Fibre Channel	A6826A	11i/Yes	LC (SFF)	Yes / Yes	16 / 32
PCI-X 2 channel Smart Array 6402 128 MB (not supported in SEU 2)	A9890A	11i/Yes	VHDCI	Yes / Yes	8 / 16
PCI-X 4 channel Smart Array 6404 256 MB (not supported in SEU 2)	A9891A	11i/Yes	VHDCI	Yes / Yes	8 / 32
<b>Local Area Network Interface Cards</b>					
PCI-X 1 port 10 GB Ethernet Fiber Adapter	AB287A	11i v2/Yes	Duplex LC	Yes / Yes	2 / 2
PCI-X 4 port 1000Base-T Gigabit Adapter	AB545A	11i v2/Yes	RJ-45	Yes / Yes	16 / 64
PCI-X Dual port 1000Base-SX	A7011A	11i v2/Yes	Duplex SC	Yes / Yes	16 / 32
PCI-X Dual port 1000Base-T	A7012A	11i v2/Yes	RJ-45	Yes / Yes	16 / 32
PCI-X 1000Base SX	AD332A	11i v2/Yes	Duplex SC	Yes / Yes	16 / 32
PCI-X 1000Base-T	AD331A	11i v2/Yes	RJ-45	Yes / Yes	16 / 32
<b>Multi-Function Cards (Mass Storage &amp; LAN)</b>					
PCI-X 4 GB Fibre Channel, 1000Base-T	AD193A	11i v1/yes	LC (SFF) /RJ-45	Yes / No	16 / 32



### Configuration

PCI-X 2 port 4GB FC, 2 Port 1000Base-T	AD194A	11i v1/yes	LC (SFF) /RJ-45	Yes / No	16 / 32
PCI-X 2 GB Fibre Channel, 1000Base-SX	A9782A	11i/Yes	LC (SFF)/LC GigE	Yes / Yes	16 / 32
PCI-X 2 GB Fibre Channel, 1000Base-T	A9784A	11i/Yes	1LC/1 RJ-45	Yes / Yes	16 / 32
PCI-X 2 port 2GB FC/2 port 1GB Ethernet	AB465A	11i v2/Yes	2 LC/2 RJ-45	Yes/Yes	16/64
PCI X 2 port 1000Base T/2 port Ultra320 SCSI	AB290A	11i/Yes	2 LC GigE/2 RJ-45	Yes / Yes	16/64
<b>Wide Area Network Interface Cards</b>					
2-port Programmable Serial Interface (PSI) X.25/Frame Relay/SDLC	J3525A	11.00/No	RS 530, RS-232, V.35, RS-449 or X.21	Yes / Yes	16 / 32
<b>Additional Interface Cards</b>					
PCI 8-port Terminal Multiplexer	A6748A	11.00 / No	RS-232	Yes / No	16 / 128
PCI 64-port Terminal Multiplexer	A6749A	11.00 / No	RS-232 or RS-422	Yes / No	16 / 1024
PCI Hyperfabric2 Fiber Adapter	A6386A	11.00 / No	LC Duplex	Yes / Yes	4 / 4

### External Server Storage Connectivity

HP has the broadest, most robust server and storage line up in the industry, providing exactly the right fit for every need. Refer to the Storage Server matrix to see a matrix that highlights which storage device, server and operating system is interoperable.

### Integrated Multifunction I/O

The HP 9000 rp8440 Server chassis supports either one or two Core I/O cards (AB314A). Core I/O slots are located along the right rear vertical edge of the chassis. One core I/O card is included with each system. The first core I/O card will support up to four cell boards in the server and all I/O slots. For support of two hard partitions, a second core I/O is required in the host system. For support of three or four hard partitions (nPars), a third and/or fourth core I/O card can be added in the rp8440 Server Expansion Unit 2. See the SEU 2 section for more details. HP 9000 rp8400/rp8420 Core I/O cards cannot be carried forward to the HP 9000 rp8440 server.

Each Integrity core I/O card provides the following features:

- Management Processor: The Management Processor (MP) is a dedicated processor that simplifies and extends system management, as well as, enhances serviceability. The MP feature set was designed to minimize/eliminate the need for the System Administrator to be physically at the system to perform tasks such as diagnostics, system management, or even hard resets. The MP in the rp8440 can be configured to failover to a secondary MP (again provided two core I/O board sets are installed). Here are some of the features enabled by the HP 9000 rp8440 Server management processor:
- Features:
  - System management over the Internet or Intranet
  - System console redirection
  - Console mirroring
  - System configuration for automatic restart
  - Viewing history log of system events
  - Viewing history log of console activity
  - Setting MP inactivity timeout thresholds
  - Remote system control
  - Remote power cycle (except for MP housekeeping power)

### Configuration

- Viewing system status
- Event notification to system console, e mail, pager, and/or HP Response Centers
- Automatic hardware protection of critical environmental problems
- Access to management interface and console(s) on LAN failure (modem required)
- Auto system restart
- Remote resetting of hardware partitions
- Forward progress indicator (Virtual front panel)
- Out of band Manageability and PDC firmware update
- Configure manageability and console security
- SSL
- External LAN port: 1 GbE LAN port using an RJ 45 connector
- External SCSI port: Ultra320 SCSI port for connections to mass storage or media.
- Access to internal peripheral bay: The first core I/O card enables half of the HP 9000 rp8440 Server peripheral bay, which includes one removable media and two low profile disks. The second core I/O card enables the remaining internal peripherals, two disks and one removable media bays. Customers that require access to more than two internal disks and/or one removable media slot must purchase the second core I/O card and more than one cell board.

The integrated multifunction I/O provides core I/O functionally and includes the Management Processor technology.

---

#### Core I/O Loading Rules

- 1 Core I/O card is included with each HP 9000 rp8440 Server
- Load the first Core I/O board into slot 0.
- Core I/O slot 0 corresponds to Cell Board slot 0. Core I/O slot 1 corresponds to Cell Board slot 1.
- A cell board must be installed in slot 0 to enable use of Core I/O 0. Likewise, a cell board must be installed in slot 1 to enable use of Core I/O 1.
- Access to two internal disk drives and one Removable Media bay is enabled with the installation of the first Core I/O board.
- The optional second Core I/O board must be ordered to enable hardware partitioning (systems not using the Server Expansion Unit 2).
- The optional second Core I/O board must be ordered to enable access to the third/fourth internal disks and second removable media drive. (**NOTE:** For support of 3 or 4 hard partitions [nPartitions], a third and fourth core I/O board is included in the rp8440 Server Expansion Unit 2. See the SEU 2 section for more details.)

---

#### Internal Disk Drives

HP 9000 rp8440 Server supports up to four internal low profile hot plug disk drives.

### Configuration

Product Number	Disk Capacity	Rotational speed	Average seek time (read/write)	Sustained Bandwidth
AD146A	36 GB	15,000 RPM	3.6 msec (read); 3.9 msec (write)	40 MB/s
AD147A	73 GB	15,000 RPM	3.6 msec (read); 3.9 msec (write)	40 MB/s
AD148A	146 GB	10,000 RPM	4.7 msec (read); 5.2 msec (write)	40 MB/s
AD149A	300 GB	10,000 RPM	4.7 msec (read); 5.2 msec (write)	69 MB/s
AD210A	146 GB	15,000 RPM	3.6 msec (read); 3.9 msec (write)	40 MB/s
AD265A	300 GB	15,000 RPM	3.6 msec (read); 3.9 msec (write)	40 MB/s

HP 9000 rp8400/rp8420/rx8620 disk drives can be carried forward to the HP 9000 rp8440 server.

For HP-UX:

- Independent UltraSCSI controllers provide each disk drive with an independent SCSI channel
- Supported by MirrorDisk/UX across disk drives, controllers, and Core I/O boards
- Must order two Core I/O cards to support more than two internal disk drives

#### Internal Removable Media

- HP 9000 rp8440 Server contains two removable media bays, which will support either a DVD+RW or DAT drive. Removable media drives are not hot plug capable.
- DVD+RW drive provides enhanced features while preserving backward read compatibility with CD ROM. Data transfer rates of up to 6.75 MB/s are achieved with the DVD format; 4.8 MB/s can be achieved with the CD format. (**NOTE: Installing the Smart Array card connected to the internal drives does not affect the function of the DVD ROM.**)
- DAT 72GB drive has a maximum storage capacity of 72 GB and is RoHS compliant.
- Must order two Core I/O cards to enable more than one Internal Media device.
- HP rp8400/rp8420/rx8620 removable media drives can be carried forward to the HP 9000 rp8440 server

#### Internal Removable Media Specifications

Product Number	Device	Capacity	Data transfer rate
AB351B*	DVD+RW (RoHS)		
AB400A**	DAT 72	72 GB	

\*NOTE: Third Party software (not included with AB351A) is required to support DVD write capability with Windows.

\*\*NOTE: Not supported with Linux.

**I/O Configuration Rules** The following table summarizes previously mentioned configuration rules pertaining to usage of I/O slots and internal peripherals.

Configuration	Minimum Number of Cells	Minimum Required Number of Core I/Os
>8 I/O card slots	2	1
>2 Internal Disks	2	2
2 Internal Removable Media	2	2
2 Partitions	2	2

### Configuration

**Addition I/O resources using the Server Expansion Unit (SEU)** Additional I/O resources can be obtained by adding the HP Server Expansion Unit 2 (SEU 2). The SEU 2 is an add on chassis containing I/O resources that complement the I/O and partitioning capabilities within the HP 9000 rp8440 Server. The SEU 2 mirrors the I/O resources embedded within the HP 9000 rp8440 Server chassis, adding 16 I/O card slots, 4 disk bays, 2 removable media slots, and enabling 2 additional hard partitions.

The SEU 2 must be installed in the same cabinet and directly above the host rp8440 server. Please refer to the Server Expansion Unit 2 section in this guide or more specific details.

The following table summarizes the I/O configuration rules when an SEU 2 is configured with the HP 9000 rp8440 Server.

Required Configuration	Minimum Required Number of Cells	Minimum Required Number of Core I/Os
>16 I/O card slots	3	4 <sup>1</sup>
>24 I/O card slots	4	4 <sup>1</sup>
>4 Disks	3	4 <sup>1</sup>
>6 Disks	4	4 <sup>1</sup>
3 Removable Media	3	4 <sup>1</sup>
4 Removable Media	4	4 <sup>1</sup>
3 Hard Partitions	3	4 <sup>1</sup>
4 Hard Partitions	4	4 <sup>1</sup>

**NOTE 1:** Two Core I/O cards are included in each SEU

### AC/DC Power

#### DC Power Supplies

The HP 9000 rp8440 Server supports up to six hot swap bulk power supplies for 2N+1 protection. The hot swap design allows for the replacement of a failed power supply without interrupting server operation. Two supplies are included with the base system. A minimum of one additional supply is required for each cell board. Following this rule, all configurations will have 2N+1 power protection. HP rp8400/rp8420/rx8620 DC power supplies can be carried forward to the HP 9000 rp8440 server.

#### PCI Power Supplies

PCI power supply is now a redundant N+1 design. One PCI power supply failure will not affect the I/O bay since the remaining PCI power supply will power both I/O bays (this is an upgrade from the sx1000 based systems). PCI power supplies are hot swap capable (this is an upgrade from the sx1000 based systems). HP rp8400/rp8420/rx8620 PCI power supplies cannot be carried forward to the HP 9000 rp8440 server.

#### AC Power

The HP 9000 rp8440 Server contains four C20 power receptacle ports located at the bottom rear bulkhead. A minimum of two power cords must be used to maintain normal operation of the HP 9000 rp8440 Server. A second set of two cords can be added to improve system availability by protecting, for example, against power grid failures or accidentally tripped circuit breakers. The HP 9000 rp8440 Server hardware is capable of receiving AC input from two different AC power sources. The objective is to maintain full equipment functionality when operating from power source A and power source B, or A alone, or B alone. This capability is called "fault tolerant power compliance."

Although many HP 9000 rp8440 Server configurations can be sufficiently powered from a single 16 /20 amp branch circuit, HP strongly recommends using one 16 amp (minimum) branch circuit per power cord. Due to the variety of 16/20 plugs used throughout the world, the HP 9000 rp8440 Server menu offers a choice of plug options.

### Configuration

All HP 9000 rx8620 servers are shipped with four AC power cords.

#### AC Power Consumption

- The HP 9000 rp8440 Server power consumption will vary greatly depending on the hardware configuration and the input line voltages supplied at customer sites. Because of the disparity of line voltages throughout the world it's best to represent power consumption in VA (Volt Amperes). With power consumption being of high concern throughout the world, it's necessary to specify consumption in a couple of different ways.
- Maximum Theoretical Power or "Maximum Configuration" (input power at the AC input expressed as volt amps to take into account power factor correction)-The calculated sum of the maximum worst case power consumption for every subsystem in the server. This number will never be exceeded by a functioning server for any combination of hardware and software under any conditions.
- Marked Electrical Power (input power at the AC input expressed as volt amps)-The server Marked Electrical Power is the rating given on the chassis label and represents the input power required for facility AC power planning and wiring requirements. This number represents the expected maximum power consumption for the server based on the power rating of the bulk power supplies. This number can safely be used to size AC circuits and breakers for the system under all conditions.
- Typical Maximum Power, User Expected Maximum Power, or "Typical Configuration" (expressed as volt amps)-The measured maximum worst case power consumption. This number represents the largest power consumption that HP engineers were able to produce for the server with any combination of hardware under laboratory conditions using aggressive software applications designed specifically to work the system at maximum load. This number can safely be used to compute thermal loads and power consumption for the system under all conditions.

Power Numbers per configuration are shown below. For further power consumption details, see the HP 9000 rp8440 Installation Manual.

---

### Configuration

#### HP 9000 rp8440 Server Fully Loaded Configuration

- 16 dual core HP PA 8900 1.068 GHz processors /533 MHz Front Side Bus
- 256 GB of Memory
- 16 PCI cards
- 4 cell boards
- 4 internal hard drives
- 2 DVD drives
- 2 Core I/O cards
- 6 bulk power supplies.
- Typical maximum power: 3,866 VA (3,789 W) (19.33 A @ 200 VAC across 2 cords)
- Marked Electrical for the server: 5400 VA (30 A @ 180 VAC across 2 cords)
- Marked Electrical per line cord: 2700 VA (15A @ 180 VAC across each cord)
- Maximum theoretical power: 5,720 VA (5,837 W) (28.6 A @ 200 VAC across 2 cords)

#### HP 9000 rp8440 Server Average Configuration

- 8 dual core HP PA 8900 1.068 GHz processors
- 16 GB of Memory
- 8 PCI cards
- 2 cell boards
- 2 internal hard drives
- 1 DVD drives
- 2 Core I/O cards
- 
-

### Configuration

- 3 bulk power supplies.
- Typical power consumption: 1870 VA (9.35 A @ 200 VAC across 2 cords)

#### Power Distribution Units

##### 60 amp Power Distribution Unit

- AF916A (NA/JPN) and AF917A (International)-supported with 10K G2 rack
- E7683A (US) and E7684A (International)-supported in Rack System E

A 60 amp Power Distribution Unit (PDU) has been developed for Integrity customers that prefer to use fewer, higher amperage connections into their wall electrical infrastructure. This PDU is sold separately and can be ordered with any HP Server solution. For more details on PDUs, please refer to the PDU sales collateral.

The drawing below is an example of how the PDU can be configured with the HP 9000 rp8440 Server in a dual grid configuration. In this case there are two HP 9000 rp8440 servers (average configurations drawing ~9 amps each) and two 60 amp PDUs configured with redundant power. The blue cords represent the primary power connections needed for normal operation. In this example, cords from each server are plugged

into a separate branch circuits. However, it is acceptable, for lower VA configurations, for each server to plug both grid A cords into one branch circuit and both grid B cords into second branch circuit. The remaining PDU outlets can be used to power other components as long as the specifications for the PDU rating are not exceeded.

For redundant power inputs, the second set of red cords is added. If the second PDU is plugged into a second grid this configuration provides protection against:

- Losing power from a single power grid
- Accidental tripping of one or two circuit breakers
- Accidental disconnect of a single PDU power cord
- Accidental disconnect of up to four system power cords

##### 30 amp Power Distribution Unit-

- 252663 D74 (NA/JPN) and 252663 B33 (International)-supported on 10K G2 rack
- E7681A (NA/JPN) and E7682A (International)-supported on Rack System E

A 30 amp Power Distribution Unit (PDU) is also supported with HP 9000 rp8440 Server. This PDU is sold separately and can be ordered with any HP Server solution.

The following configuration guidelines apply when using the 30 amp PDU:

- HP 9000 rp8440 Server plugs A0 and A1 should be plugged into the same PDU
- Ax and Bx cords should never be plugged into the same PDU
- Use two 30 amp PDUs to achieve input power redundancy. A0/A1 and B0/B1 into separate PDUs.
- Ordering tools will not force the purchase of a second PDU for input power redundancy. A second PDU must be manually selected if redundant input power is desired.

### Configuration

#### Partitioning

A hardware partition corresponds roughly to a single, standalone system. The HP 9000 rp8440 Server can be subdivided into four partitions, each containing one or more cells that communicates coherently over a high bandwidth, low latency crossbar fabric. Special programmable hardware in the cells defines the boundaries of a partition in such a way that the isolation is enforced from the actions of other partitions. Each partition runs its own independent instance of the operating system (HP UX 11i v1, v2 and v3). Applications cannot span partitions since each partition runs its own instance of the OS, essentially functioning as a stand alone server. However, different partitions may be executing the same or different revisions of an operating system, or they may be executing different operating systems, with OS availability.

Each partition has its own independent processors, memory and I/O resources consisting of the resources of the cells that make up the partition. Resources may be removed from one partition and added to another without having to physically manipulate the hardware just by using commands that are part of the System Management interface. With future releases of HP UX and Windows, using the related capabilities of dynamic reconfiguration (e.g. on line addition, on line removal), new resources may be added to a partition and failed modules may be removed and replaced while the partition continues in operation.

Partitioning the resources of the complex in this way makes it easy to run multiple applications on the same physical system; you can allocate physical resources and tune the operating system running on each partition depending on the needs of the application (or the most important application) you intend to run on it. Alternatively, you can configure the HP 9000 rp8440 Server as a single partition, allowing all the resources to be focused on a single set of tasks, for example a large online transaction processing application.

You can increase or reduce the processing power of a partition by adding or deleting cells. With the rp8440, you must shut down the operating system running on the affected partition(s) before moving cells, and before making configuration changes that will take effect. Though the OS may include commands for some configuration tasks, HP recommends you use the Partition Manager (parmgr) to configure partitions.

Hardware based partition configuration changes may require a reboot of the partition depending upon the configuration change. The reboot of the partition only affects the partition that is being reconfigured. The other partitions defined in the chassis are not affected and will continue to execute without interruption. In a future HP UX release, dynamic hard partitions will be supported. Dynamic partitions imply that partition configuration changes do not require a reboot of the partition.

The HP 9000 rp8440 Server can be divided into four independent hardware partitions when configured with the HP Server Expansion Unit 2. In a partitioned configuration, I/O bay resources such as I/O slots, core I/O, disk and removable media bays, are always dedicated to the corresponding cell board slot. In other words, I/O bay 0 resources are always configured to the cell board in Cell slot 0. Therefore, in a partitioned system, the amount of resources within a partition is always proportional to the number of cells within that partition. There is no flexibility to otherwise divide these components. For example, in a system configured with two cells in separate nPars, it is not possible to include twelve I/O slots in partition 0 and four I/O slots in partition 1. Please refer to the "HP Server Expansion Unit 2" section in this guide or more specific details.

The table below summarizes the resource availability based on hardware partitions.

### Configuration

Number of Hard Partitions	Minimum # of Cells	Minimum Available I/O Slots	Core I/O (required)	Minimum Available Disk/Media Bays
1 Partition	Any one Cell	8	1	2/1
2 Partitions	Any two Cells	16	2	4/2
3 Partitions	Any three Cells	24	4	6/3
4 Partitions	Four Cells	32	4	8/4

**Software Partitioning** HP 9000 rp8440 servers support virtual partitioning (vPars) to the single processor level similar to support on HP 9000 servers with HP UX 11i v1. With vPars, a user will be able to support up to eight separate virtual partitions each with an instance of HP UX within each hard partition. vPars will provide many of the features of nPars but without the electrical isolation and support for hardware failures that nPars provides.

### HP System Insight Manager

HP Systems Insight Manager (SIM) is the central point of administration for management applications that address the HP 9000 rp7440 and rp8440 server's management requirements. HP SIM delivers powerful monitoring and control, notifying the administrator of potential hardware or software problems before they occur. It also provides inventory reporting and asset management capabilities that dramatically reduce the time and effort required to track server assets. HP SIM provides secure communications as well as role based security to make certain that its powerful capabilities are kept secure from unauthorized users.

- ### HP-UX
- Ignite UX addresses the need for HP-UX system administrators to perform fast deployment for one or many servers. It provides the means for creating and reusing standard system configurations, enables replication of systems, permits post installation customizations, and is capable of both interactive and unattended operating modes.
  - Software Distributor UX (SD UX) is the HP-UX administration toolset used to deliver and maintain HP-UX operating systems and layered software applications. Delivered as part of HP-UX, SD UX can help you manage your HP-UX operating system, patches, and application software on HP 9000 servers.
  - System Management Homepage (SMH) is used to manage accounts for users and groups, perform auditing and security operations, and handle disk and file system management and peripheral device management. HP Systems Insight Manager allows these tasks to be distributed to multiple systems and delegated using role based security.
  - HP-UX Kernel Configuration is used for self optimizing kernel changes. The new HP-UX Kernel Configuration tool allows users to tune both dynamic and static kernel parameters quickly and easily from a Web based GUI to optimize system performance. This tool also sets kernel parameter alarms that notify you when system usage levels exceed thresholds.
  - Partition Manager creates and manages nPars for high end servers. After the partitions are created, the systems running on those partitions can be managed consistently with all the other tools integrated into SIM.
  - HP-UX 11i Webmin based Admin is a Web based system management framework that allows a wide variety of open source Webmin system management modules to be plugged in. HP supports this tool for the configuration of the HP-UX 11i Apache based Web Server and the HP-UX 11i Tomcat based Servlet Engine.
  - HP-UX Bastille is a security hardening/lockdown tool that enhances the security of an HP-UX 11i UNIX host. It accommodates the various degrees of hardening required of servers used for webs, applications, and databases.
  - Security Patch Check efficiently improves systems security by performing analysis of file sets and patches installed on an HP-UX 11i system and generating a report of



### Configuration

recommended security patches.

- System Inventory Manager is for change and asset management. It enables you to easily collect, store, and manage inventory and configuration information for HP-UX-based servers. It provides an easy to use, web based interface, superior performance, and comprehensive reporting capabilities.
- Event Monitoring Service (EMS) keeps the administrator of multiple systems aware of system operation throughout the cluster, and it notifies the administrator of potential hardware or software problems before they occur. HP Systems Insight Manager can launch the EMS interface and configure EMS monitors for any node or node group that belongs to the cluster, resulting in increased reliability and reduced downtime.
- HP Process Resource Manager (PRM) controls the resources that processes use during peak system load. PRM can manage the allocation of processor, memory resources, and disk bandwidth. It allows administrators to run multiple mission critical applications on a single system, improve response time for critical users and applications, allocate resources on shared servers based on departmental budget contributions, provide applications with total resource isolation, and dynamically change configuration at any time—even under load.
- HP-UX Workload Manager (WLM) provides automatic processor resource allocation and application performance management based on prioritized service level objectives (SLOs). In addition, WLM allows administrators to set real memory and disk bandwidth entitlements (guaranteed minimums) to fixed levels in the configuration. The use of workload groups and SLOs improves response time for critical users, allows system consolidation, and helps manage user expectations for performance.
- HP OpenView Operations Agent provides a fully integrated, single pane of glass management solution for systems, networks, applications, and databases. A powerful ability to monitor, filter, correlate, and respond to events enables IT organizations to establish central management control over their managed environments and improve overall availability and reliability.
- HP OpenView Performance Agent monitors and analyzes the performance of systems and applications to compare SLOs with actual application performance, and it enables real time performance monitoring as well as action on alarm.
- HP OpenView GlancePlus is a powerful system monitoring and diagnostic tool that provides online performance information, examination of system activities, identification and resolution of performance bottlenecks, and system fine tuning.
- HP OpenView Data Protector (Omniback II) provides reliable, high performance data protection for enterprise wide heterogeneous environments without impacting system or application performance. It centralizes and automates backup and recovery operations and tracks file versions and media to enable swift recovery of information.
- HP OpenView Network Node Manager (NNM) management station runs on Itanium 2 based HP-UX servers. NNM provides a powerful network management solution that includes concise, in depth views of network devices and their status in an intuitive graphical format. NNM helps network managers evaluate network performance, pinpoint problem sources, and proactively manage their networks and network availability.
- All other HP OpenView management tools, such as HP OpenView Operations, Service Desk, and Service Reporter, will be able to collect and process information from the agents running on HP9000 or HP Integrity servers with HP-UX.

### Configuration

#### Racking

The HP 9000 rp8440 Server was designed to provide industry leading performance density and availability when ordered in a racked configuration. At 17 EIA units (29.75 inches), two HP 9000 rp8440 servers can be mounted into a single HP rack two meter cabinet with 7 or 8 EIA units of extra space for mounting external peripherals. One rp8440 can be mounted in a rack along with a Server Expansion Unit 2.

The HP 9000 rp8440 Server industrial design and packaging was designed to allow easy and quick access to all of the system's components. The most frequently handled devices, removable media and disks, are directly accessible at the system's front. By removing the front bezel, hot swap fans, hot swap power supplies, and PCI power supplies can be completely serviced. At the rear, core I/O and more hot swap fans are directly accessible. For access to all other components, the rack mounted HP 9000 rp8440 Server comes with rack sliders.

These rack sliders enables the HP 9000 rp8440 Server to be slid forward out of the HP Rack cabinet for servicing of internal components such as fans, cell boards, and I/O cards, while the system is still running. The sliders also allows for servicing or replacement of any FRU (field replaceable unit) without removing the chassis from the cabinet. The HP 9000 rp8440 Server industrial design and slider strategy enables access and removal of any FRU within 15 minutes or less. This design feature minimizes the downtime associated with system upgrades in the rare event of a component failure. Also included with ever rack mounted HP 9000 rp8440 Server is a cable management arm (CMA). The CMA neatly secures data cables and prevents cables from becoming entangled while servicing of the system.

The following racking rules apply for HP 9000 rp8440 servers configured with an HP Server Expansion Unit 2 that is factory integrated:

- The HP Server Expansion Unit 2 must be mounted in the same cabinet as the host HP 9000 rp8440 Server.
- The HP 9000 rp8440 Server must be mounted directly below the HP Server Expansion Unit

When adding an SEU 2 in the field to an existing host server, It is preferred that the SEU 2 be installed directly above the host server. When not possible to install the SEU 2 above the host server in the field, it is supported to install the SEU 2 in an adjacent rack. Please consult the SEU 2 install guide for more details.

---

#### Heavy Duty Stabilizing Kit for 10K G2 Universal Rack (not used with Rack System E)

A heavy duty stabilizing kit is required for the rack of the rp8440 server to add stability for the HP Universal 10K G2 rack. With this stabilizing kit, the ballast is no longer needed with the new HP Universal rack. Use of the Heavy Duty Stabilizing kit is mandatory and should be installed immediately.

---

#### Ballasts for Rack System E Cabinets (not used with Universal Rack 10K G2)

Due to the weight of the HP 9000 rp8440 Server, ballast kits have been developed to add stability to HP Rack Systems/E cabinets while the system is being serviced. Every HP 9000 rp8440 Server shipped to customers will be shipped with a ballast kit. These ballasts were designed to easily attach to the rear anti tip foot that comes standard with every HP Rack System E cabinet. Use of the HP 9000 rp8440 Server ballast kit is mandatory and should be installed immediately.

---

### Configuration

#### UPS

Management of local UPSs for the rx7640 and rp8440 is now through a LAN port on the core I/O card. Management of UPSs by the predecessor, rx7620 and rx8620 servers was through a serial port on the core I/O. The serial port is not available on the rx7640 and rp8440 servers. Therefore, when upgrading or adding rx7640 and rp8440 servers to your environment and using local UPSs (as opposed to datacenter wide UPSs), make sure there is a LAN management card available on the local UPS.

#### HP 10000 and 9000

**Racks** (These racks are the pre merger Compaq racks)

The HP 9000 and Integrity servers are supported for field installs into these racks. Factory integration will not be supported for HP 10000 and HP 9000 racks. Differing depth requirements of the HP 9000/Integrity racking kits preclude racking HP 9000/Integrity servers and HP ProLiant servers in the same racks.

#### Third-Party Racking

HP Servers are designed to maximize performance density when installed into HP Rack Systems. HP Rack Solutions maintain the high level of safety and reliability of HP Server solutions that customers have come to expect. Although HP strongly recommends racking servers in HP Rack Solutions, it recognizes that some customer circumstances may prohibit this. For those customers, HP has developed a set of guidelines that when followed, enables server installations into third party cabinets. It is extremely important that the guidelines be followed due to the wide variety of cabinets in the market place.

### Upgrades

#### HP 9000 rp84xx Upgrades to HP 9000 rp8440 Servers

All HP rp84xx servers are in box upgradeable to rp8440 servers in the current chassis. In box upgrades may take one to two 8 hour periods either of successive days or using successive shifts on the same day. In box upgrades will have the advantage of asset tag retention.

You can also accomplish an upgrade by combining the purchase of a new server with Trade Up credits on the older server. Box swap upgrades may have the advantage of less upgrade down time.

In box upgrades and box swap upgrades may have similar prices depending on the amount of memory and number of cell boards and processors that have to be upgraded.

#### Included in the In box Upgrade Kit (AD056A)

- System Backplane-The HP 9000 rp8440 server backplane is a new design with the following feature modifications:
  - New high speed differential links
  - Redesign of the crossbar ASIC
  - Additional switch fabric on the backplane
  - Redesign of the backplane power subsystem
  - Redesign of the system clock infrastructure
  - New high speed, impedance controlled, board to board connectors will be used
- Mass Storage Backplane PCA-the mass storage subsystem upgrades from SCSI SE interconnect to U320.
- Other Miscellaneous
  - Nameplates and labels
  - "Read Me" documents, Upgrade Guide, CD ROM
  - Miscellaneous cables

#### Must Order Separately for an In box Upgrade

- Processors - Customer won't be able to use their existing PA 8900 processors due to a faster FSB
- Cell Boards - New Cell board design to support new chipset
- Memory DIMMs - The memory system uses Double Data Rate DRAMs (DDR II)
- I/O Backplane - The I/O backplane must be ordered
- Core I/O - U320 support
- Installation services

#### Material to be Reused in an In Box Upgrade

- Chassis
- System fans
- AC power distribution PCA
- DC power distribution PCA
- OL\* PCA (I/O cards)
- Bulk power supplies
- Hard disk drives
- Removable media drives
- Supported I/O cards (please refer to supported I/O card list)

#### Upgrading to HP Integrity

Customers can also upgrade their rp8440 server to a HP Integrity rx8640 Server using the AD056A product. This upgrade kit consists of the following:

## *Upgrades*

- Nameplates and labels
- "Read Me" documents, Upgrade Guide, CD ROM
- Miscellaneous cables

For more information on upgrades, return credits and services products, please refer to the midrange upgrade guide on the Source/Partner Portal.

### Technical Specifications

**Server model number** rp8440

**Number of dual core  
HP PA 8900 Processor  
cores** 2-32

**Chipset** HP sx2000

---

**Server product  
numbers**

**Base** A9958A

**Number of dual core  
HP PA 8900 Processor  
cores** 2-32

---

**Supported Processors**

<b>Dual core PA 8900 processor</b>	L3 cache	64MB
	Core Frequency	1.068 MHZ
<b>Hardware Warranty</b>	1 year, same day, on site	

---

**Memory**

<b>Memory slots</b>	64 (16 per cell board)
<b>Minimum memory</b> (pair: 2 DIMMs)	2 GB
<b>Maximum memory capacity</b>	128 GB (32 GB per cell board)

---

**Internal Disks**

<b>Maximum disk mechanisms</b>	4
<b>Maximum disk capacity</b>	1.2 TB
<b>Maximum disk capacity</b> (8 mechanisms with SEU 2)	2.4 TB
<b>Internal Removable Media</b>	2 slots
<b>Internal removable media</b> (with SEU 2)	4 slots
<b>DVD+RW (2 additional slots with SEU 2)</b>	2 slots
<b>DAT 72 GB (2 additional slots with SEU 2)</b>	2 slots

---

## Technical Specifications

<b>Core I/O</b>	<b>Ultra320 SCSI-LVD</b>	1
	<b>1 GbE</b> (RJ 45 connector)	1
	<b>RS 232 serial port</b> (one console)	1
	<b>100Base T port</b> (LAN console connection)	1

<b>I/O Buses and Slots</b>	<b>Total Hot-plug PCI-X Slots</b> (266 MHz; 64 bits)	16
	8 Dual channel slots (2128 MB/s each)	
	6 Dual channel slots (1060 MB/s each)	
	2 Single channel (530 MB/s each)	

<b>Maximum I/O Cards</b> (See supported I/O table for specific products) (Maximums double with SEU 2)	<b>Mass Storage</b>	8-16
	<b>LAN</b>	2-16
	<b>WAN</b>	16
	<b>Multi-Function (Mass Storage / LAN)</b>	14-16
	<b>Additional Interface Cards</b>	4-16

<b>Electrical Characteristics</b>	<b>AC Input power</b>	200-240V 50/60 Hz
	<b>Hotswap Power supplies</b>	6 total, 2 included with base
	<b>Redundant AC power inputs</b>	2 required, 4 cords for 2N
	<b>Typical maximum power dissipation for maximum processor, memory, disk, I/O configurations</b>	3,789 VA (3,866 W) 18.945A @200VAC
	<b>Marked Electrical for Server</b>	5400 VA, 30A @180VAC
	<b>Marked Electrical per line cord</b>	2700 VA (15A @ 180VAC)
	<b>Power factor at full load</b>	0.98 (approximately)
	<b>kW rating for UPS loading*</b>	6.0

**\*NOTE:** Represents theoretical maximum power/heat dissipation under worst case conditions, may increase with future upgrades.

## Technical Specifications

<b>Site Preparation</b>	<b>Site planning and installation included</b>	Yes
	<b>Depth (in/mm)</b>	30 in (762 mm)
	<b>Width (in/mm)</b>	19 in (482 mm)
	<b>Height (in/mm/EIA) Racked</b>	29.75 in (755 mm)/17 units
	<b>Height (in/mm) Pedestal</b>	32.8 in (833 mm)
	<b>Weight (lb/kg)</b>	171.4 kg (378 lbs)

<b>Environmental Characteristics</b>	<b>Acoustics (sound power) at 25°C</b>	7.2 Bels LwA
	<b>Acoustics (sound power) at 30°C</b>	7.5 Bels LwA
	<b>Acoustics (operator/bystander) at 24°C</b>	61.0 dB LpA
	<b>Operating Temperature</b>	41° to 89° F (5° to 32° C) (up to 5000 ft)*
	<b>Non-operating Temperature</b>	-40° to 158° F (-40° to 70° C)
	<b>Maximum rate of temperature change</b>	20° C/hour
	<b>Operating relative humidity</b>	15% to 80%, non-condensing, max. web bulb = 26° C
	<b>Non-operating relative humidity</b>	5% to 90%, non-condensing
	<b>Operating altitude above sea level</b>	To 3.0 km (10,000 feet)
	<b>Non-operating altitude above sea level</b>	To 4.5 km (15,000 feet)

**\*NOTE:** Maximum operating temperature range up to 1.524 km (5000) ft. For higher altitudes derate the max temperature by 1° C/350meters (1000 ft) above 1.524 km (5000 ft).

<b>Regulatory Compliance</b>	<b>Regulatory Model Number</b>	RSVLA-0102
	<b>Electromagnetic Interference</b>	Complies with FCC Rules and Regulations, Part 15, as a Class A digital device. Manufacturer's Declaration to EN55022 Level A, VCCI Registered, Class 1, Korea RLL
	<b>Safety</b>	UL Listed, cUL Certified, compliant with EN 60950



## *Technical Specifications*

© Copyright 2008 Hewlett-Packard Development Company, L.P.

The information contained herein is subject to change without notice.

Intel and Itanium are registered trademarks or trademarks of Intel Corporation in the U.S. and/or other countries.

The only warranties for HP products and services are set forth in the express warranty statements accompanying such products and services. Nothing herein should be construed as constituting an additional warranty. HP shall not be liable for technical or editorial errors or omissions contained herein.