

PREFERENCE E31915-4

Built-In Electric Oven

Operating Instructions

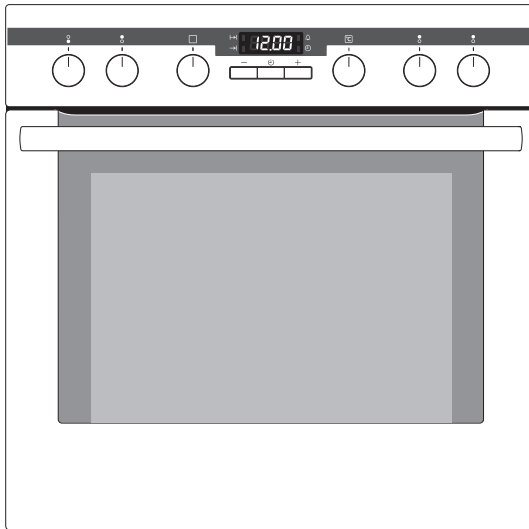

Dear Customer,

Please read these user instructions carefully and keep them to refer to later.

Please pass the user instructions on to any future owner of the appliance.

The following symbols are used in the text:



Safety instructions

Warning! Information that affects your personal safety.

Important! Information that prevents damage to the appliance.



Useful tips and hints



Environmental information

Contents

Operating Instructions	5
Safety instructions	5
Disposal	7
Description of the Appliance	8
General Overview.....	8
Control Panel	8
Oven Features.....	9
Oven accessories	10
Before Using for the first time	11
Setting and changing the time	11
Initial Cleaning.....	12
Using the Rings	13
Setting the heat setting	14
Using the Oven	15
Switching the Oven On and Off.....	15
Oven Functions.....	16
Inserting the Oven Shelf, Baking Tray and Roasting Pan	17
Non-stick accessories	18
Clock Functions	18
Switching Off the Time Display	19
Mechanical Door Lock.....	24
Uses, Tables and Tips	25
Cooking table.....	25
Baking.....	26
Baking table	28
Table for Bakes and Gratin.....	31
Frozen Ready Meals Table	31
Roasting	32
Roasting table.....	33
Grill Sizes	35
Grilling table.....	35
Defrosting.....	36
Defrosting table	36
Drying	37
Making Preserves.....	38

Cleaning and Care	40
Outside of the appliance	40
Oven interior	40
Accessories	40
Non-stick accessories	40
Shelf Support Rails	41
Oven Lighting	42
Oven Ceiling	43
Oven door	44
Oven door glass	46
What to do if	49
Service	51

Operating Instructions



Safety instructions



This appliance conforms with the following EU Directives:

- 73/23/EEC dated 19.02.1973 Low Voltage Directive
- 89/336/EEC dated 03.05.1989 EMC Directive inclusive of Amending Directive 92/31/EEC
- 93/68/EEC dated 22.07.1993 CE Marking Directive

Electrical safety

- This appliance must be only connected by a **registered electrician**.
- In the event of a fault or damage to the appliance: Take the fuses out or switch off.
- **Repairs** to the appliance must only be carried out by **qualified service engineers**. Considerable danger may result from improper repairs. If repairs become necessary, please contact our Customer Services or your dealer.

Child Safety

- Never leave children unsupervised when the appliance is in use.

Safety whilst Using

- This appliance is intended to be used for cooking, roasting and baking food in the home.
- Take care when connecting electric appliances to sockets nearby. Do **not** allow connecting leads to come into contact with or to catch beneath the hot oven door.
- **Warning: Risk of burns!** The interior of the oven becomes hot during use.
- Using ingredients containing alcohol in the oven may create an alcohol-air mixture that is easily ignited. In this case, open the door carefully. Do not have embers, sparks or naked flames in the vicinity when opening the door.



Information on acrylamides

According to the latest scientific knowledge, intensive browning of food, especially in products containing starch, can constitute a health risk due to acrylamides. Therefore we recommend cooking at the lowest possible temperatures and not browning foods too much.

How to avoid damage to the appliance

- Do not line the oven with aluminium foil and do not place baking trays, pots, etc. on the oven floor, as the heat that builds up will damage the oven enamel.
- Fruit juices dripping from the baking tray will leave stains, which you will not be able to remove. For very moist cakes, use a deep tray.
- Do not put any strain on the oven door when open.
- Never pour water directly into the oven when it is hot. This could cause damage to or discoloration of the enamel.
- Rough handling, especially around the edges of the front panel, can cause the glass to break.
- Do not store any flammable materials inside the oven. These could ignite when the oven is switched on.
- Do not store any moist foods inside the oven. This could damage the oven enamel.



Note on enamel coating

Changes in the colour of the oven's enamel coating as a result of use do not affect the appliance's suitability for normal and correct use. They therefore do not constitute a defect in the sense of the warranty law.

Disposal



Packaging material

The packaging materials are environmentally friendly and can be recycled. The plastic components are identified by markings, e.g. >PE<, >PS<, etc. Please dispose of the packaging materials in the appropriate container at the community waste disposal facilities.



Old appliance

The symbol  on the product or on its packaging indicates that this product may not be treated as household waste. Instead it shall be handed over to the applicable collection point for the recycling of electrical and electronic equipment. By ensuring this product is disposed of correctly, you will help prevent potential negative consequences for the environment and human health, which could otherwise be caused by inappropriate waste handling of this product. For more detailed information about recycling of this product, please contact your local city office, your household waste disposal service or the shop where you purchased the product.



Warning: So that the old appliance can no longer cause any danger, make it unusable before disposing of it.

To do this, disconnect the appliance from the mains supply and remove the mains cable from the appliance.

Description of the Appliance

General Overview

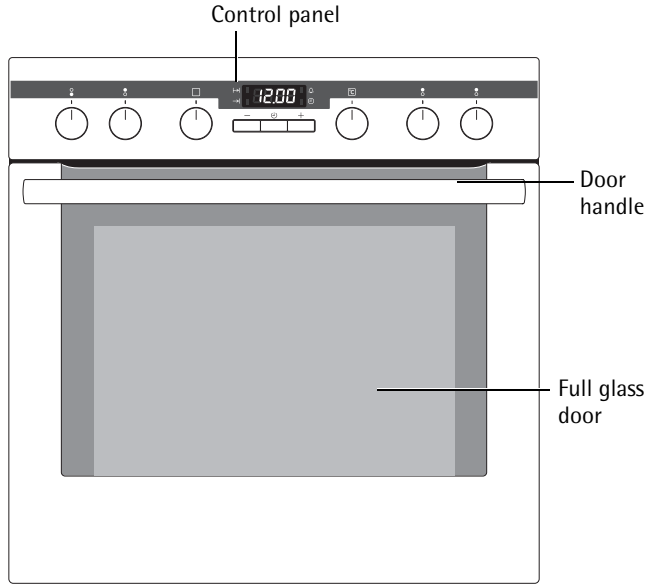

Control Panel

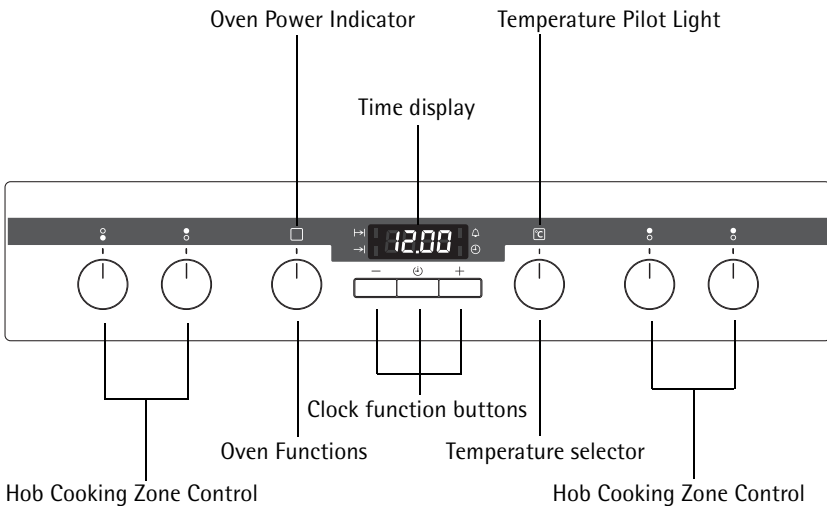

Oven Features

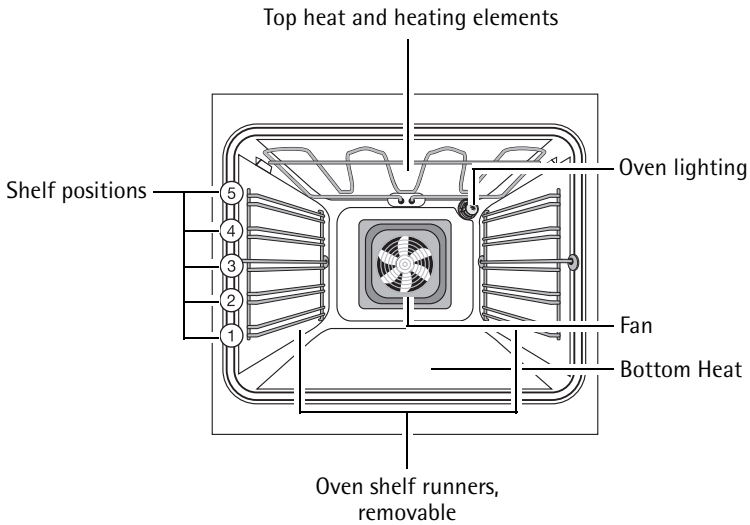

Oven steam vent

The steam from the oven is fed directly upwards via the duct in the rear of the cooking surface.

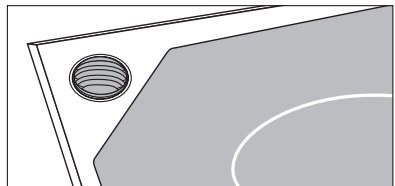

Oven accessories

Oven shelf

For cookware, cake tins, roasts and grilled foods.

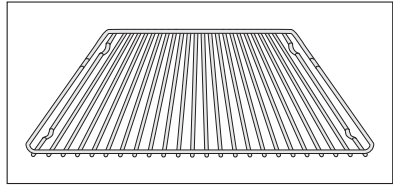

Baking tray

For cakes and biscuits.

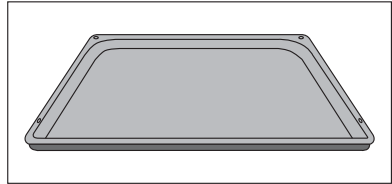

Non-stick baking tray

For cakes and biscuits.

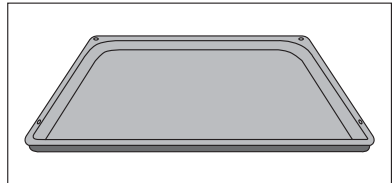

Non-stick roasting tray

For baking and roasting or as a tray for collecting fat.

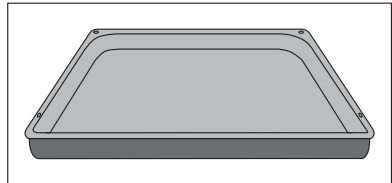



Before Using for the first time

Setting and changing the time

i The oven only operates when the time has been set.

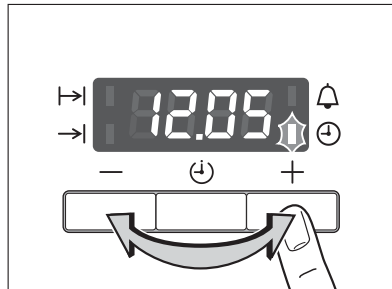
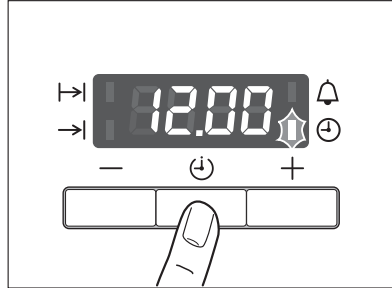

When the appliance has been connected to the electrical supply or when there has been a power cut, the function indicator Time  flashes automatically.

1. To change a time that has already been set, press the Selection  button repeatedly until the function indicator Time  flashes.
2. Using the + or - button, set the current time.



After approx. 5 seconds, the flashing stops and the clock displays the time set.

The appliance is now ready to use.

i The time can only be changed if no automatic function (Cook time  or End time ) has been set.

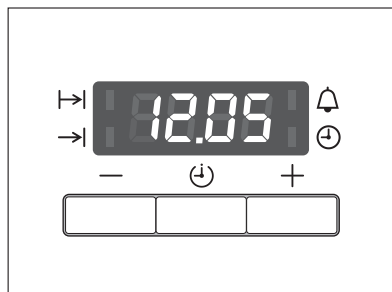

Initial Cleaning

Before using the oven for the first time you should clean it thoroughly.



Caution: Do not use any caustic, abrasive cleaners! The surface could be damaged.



To clean metal fronts use commercially available cleaning agents.

1. Turn the oven function switch to oven lighting .
2. Remove all accessories and the shelf support rails and wash them with warm water and washing up liquid.
3. Then wash out the oven with warm water and washing-up liquid, and dry.
4. Wipe the front of the appliance with a damp cloth.

Using the Rings

i Also refer to the operating instructions for your built-in hob. It contains important information on ovenware, operation, cleaning and care.

Heat settings

- You may select the heat settings within the range of settings 1-9.
- Intermediate positions may be selected between settings 2 and 7.

1 = lowest heat setting

9 = highest heat setting



Switch the cooking zone off approx. 5-10 minutes before cooking is finished to make use of the residual heat. This saves electricity.



The cooker has **pop-up ring switches**.

Press the ring switch to use it. The switch will then pop up.

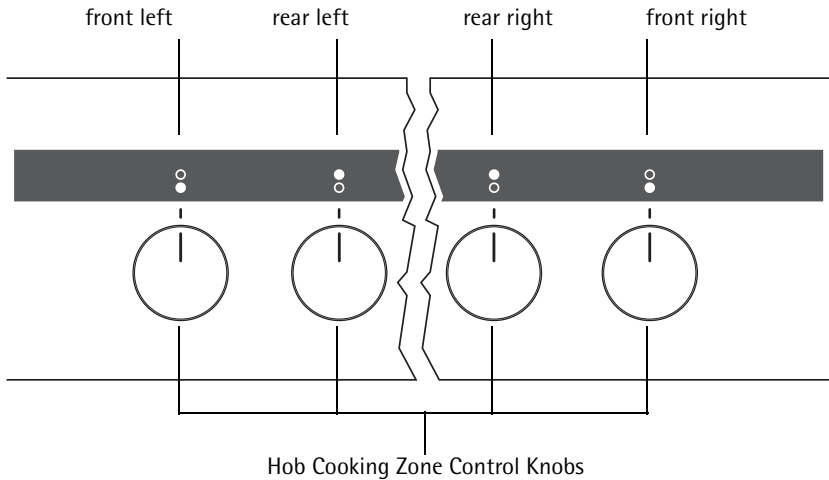

Setting the heat setting

1. Select the heat setting.

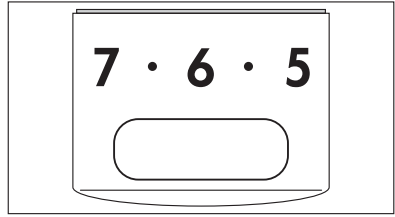

2. To end the cooking process, turn back to the Off position.



The corresponding ring pilot light is lit while the ring is operating.

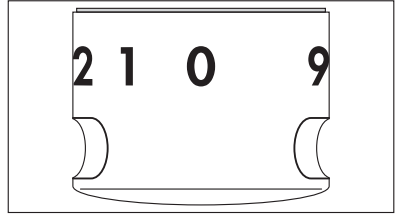

Using the Oven

- i** The oven is equipped with **retractable buttons** for "Oven functions" and "Temperature selection". To use, press the relevant button. The button then sticks out.

Switching the Oven On and Off

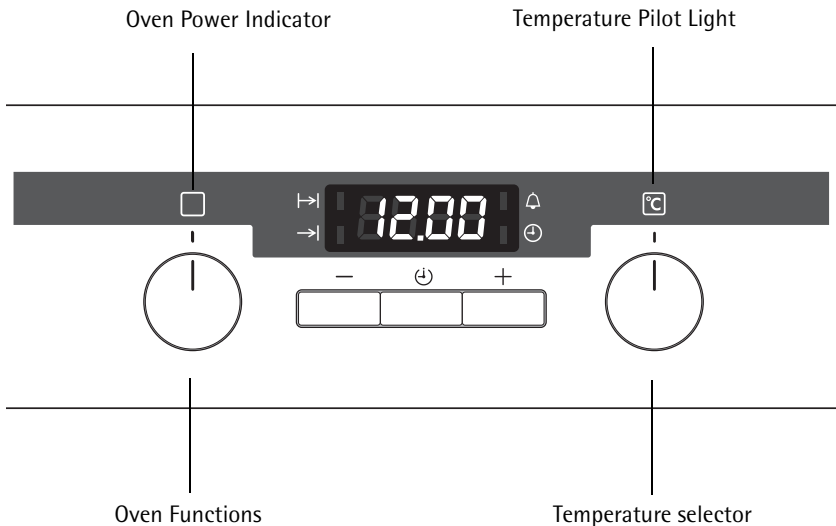



1. Turn the oven functions dial to the desired function.
2. Turn the temperature selector to the desired temperature.
The power indicator is lit as long as the oven is in operation.
The temperature pilot light is lit as long as the oven is heating up.
3. To turn the oven off, turn the oven functions dial and the temperature selector to the Off position.

- i** **Cooling fan**
The fan switches on automatically in order to keep the appliance's surfaces cool. When the oven is switched off, the fan continues to run to cool the appliance down, then switches itself off automatically.

Oven Functions

The oven has the following functions:

	Oven function	Application	Heating element/ fan
	Light	Using this function you can light up the oven interior, e.g. for cleaning.	---
	Fan-assisted circulation	For baking on up to two oven levels . Set the oven temperatures 20–40 °C lower than when using Conventional.	Top heat, bottom-heat, fan
	Conventional	For baking and roasting on one oven level .	Top heat, bottomheat
	Bottom heat	For baking cakes with crispy or crusty bases .	Bottom heat
	Defrost	For defrosting e. g. flans and gateaux, butter, bread, fruit or other frozen foods .	Fan
	Grill	For grilling flat foodstuffs placed in the middle of the grill and for toasting .	Grill
	Dual grill	For grilling flat foodstuffs in large quantities and for toasting .	Grill, top heat
	Rotitherm	For roasting larger joints of meat or poultry on one level. The function is also suitable for gratinating and browning .	Grill, top heat, fan

Inserting the Oven Shelf, Baking Tray and Roasting Pan



Shelf runner safety and anti-tip device

As a shelf runner safety device, all insertable components have a small curved indentation at the bottom on the right and left-hand edge. Always insert insertable components so that this indentation is at the back of the oven interior. This indentation is also important for preventing the insertable components from tipping.

Inserting the baking tray or roasting pan

Push the baking tray or roasting pan between the guide bars of the selected oven level.

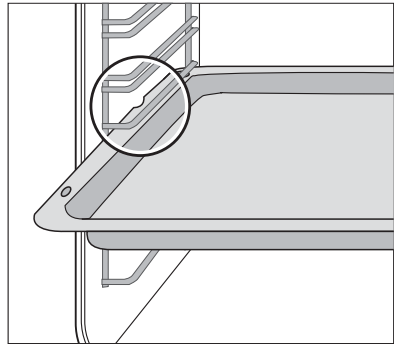

Inserting the oven shelf:

Insert the oven shelf so that the feet point downwards. Push the oven shelf between the guide bars of the selected oven level.



The high rim around the oven shelf is an additional device to prevent cookware from slipping.

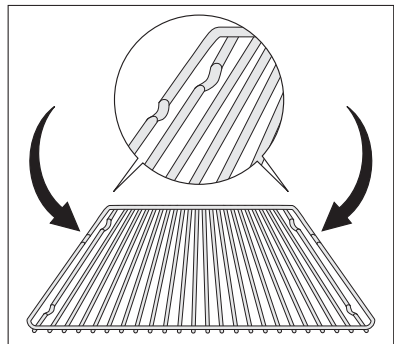

Inserting the oven shelf and roasting pan together

Lay the oven shelf on the roasting pan. Push the roasting pan **between** the guide bars of the selected oven level.

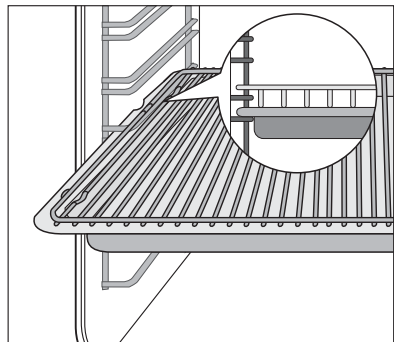

Non-stick accessories

To ensure that this accessory remains stable and permanently easy to clean, you should follow these instructions:

- Do not put accessories into the oven without any food.
- Do not place accessories on hot cooking surfaces, as the non-stick properties can be damaged by overheating.

Clock Functions

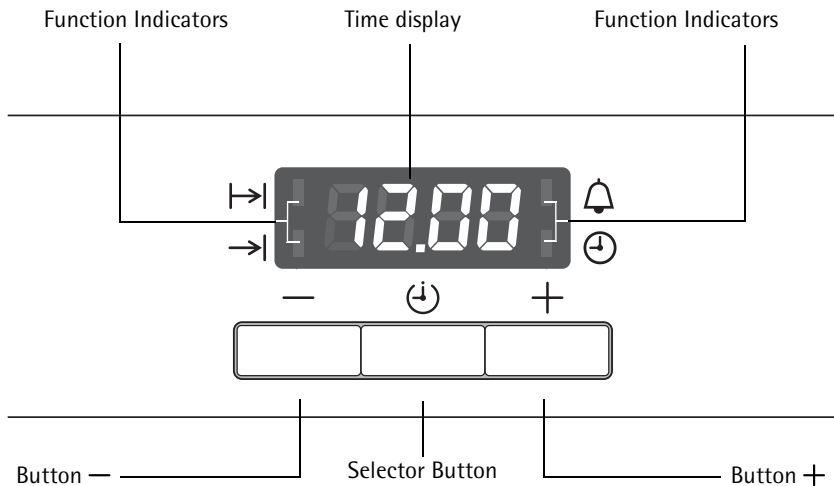

Countdown

To set a countdown. A signal sounds after the time has elapsed. This function does not affect the functioning of the oven.

Cook time

To set how long the oven is to be in use.

End time



To set when the oven is to switch off again.

Time

To set, change or check the time
(See also section "Before Using for the First Time").



How to use the clock functions

- After a function has been selected, the corresponding function indicator flashes for about 5 seconds. During this period, the desired times can be set using the + or - button.
- When the desired time has been set, the function indicator continues to flash for approx. 5 seconds. After that the function indicator is then lit. The set time begins to run.
- Press any of the buttons to stop the audible signal.
- The desired oven function and temperature can be selected before or after the clock functions Cook time  and End time  are set.
- When the cooking process is completed, turn the oven function dial and the temperature selector back to the OFF position.



Switching Off the Time Display

By switching off the time display you can save energy.



Switching off the time display

Press and hold down any two buttons until the display becomes dark (approx. 10 seconds).



Switching on the time display

Press and hold down any button until the time reappears in the display (approx. 10 seconds).



The display can only be switched off if none of the clock functions Cook time , End time  or Countdown  is in use.

Countdown

1. Press the Selection  button repeatedly until the function indicator Countdown  flashes.

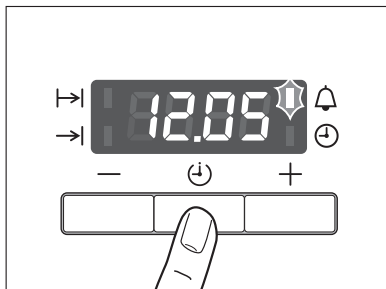

2. Using the + or - button set the desired Countdown (max. 2 hours 30 minutes).

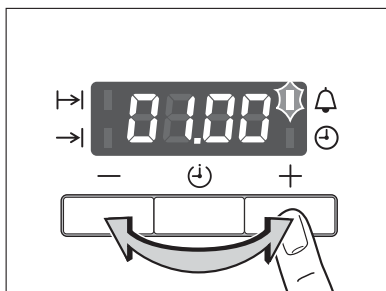

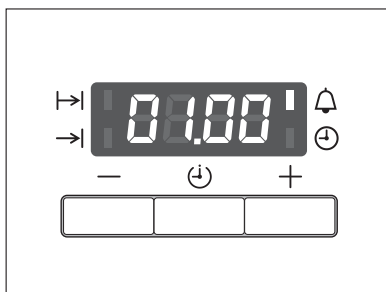

After approx. 5 seconds the display shows the time remaining. The function indicator Countdown  lights up.

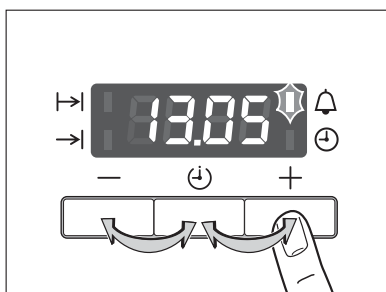

When the time has elapsed, the function indicator flashes and an audible signal sounds for 2 minutes. The signal can be stopped by pressing any button.



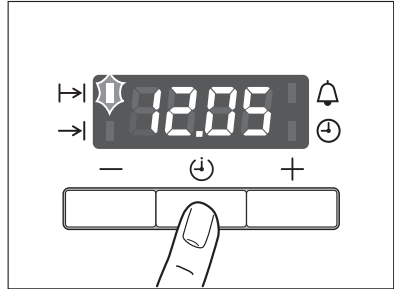

Cook time

1. Press the Selection  button repeatedly until the function indicator Cook time  flashes.

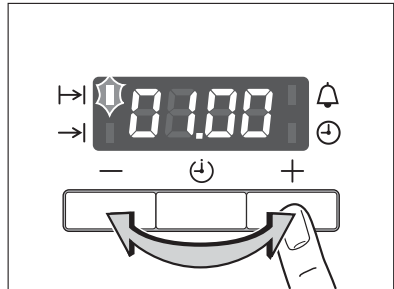

2. Using the + or - button set the desired cooking time.



After approx. 5 seconds the display returns to showing the current time. The function indicator Cook time  lights up.

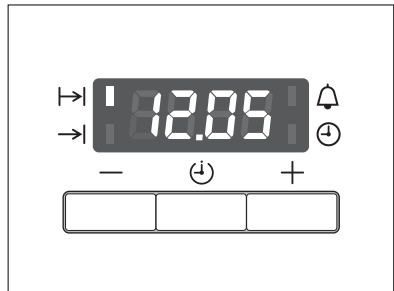

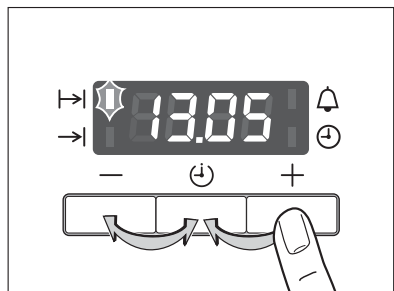

When the time has elapsed, the function indicator flashes, an audible signal sounds for 2 minutes and the oven switches itself off.

3. The signal and the programme can be stopped by pressing any button.



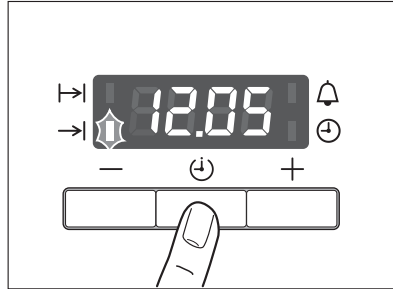

End time

1. Press the Selection  button repeatedly until the function indicator End time  flashes.

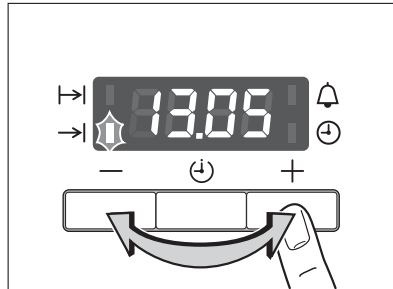

2. Using the + or - button set the desired switch-off time.



After approx. 5 seconds the display returns to showing the current time. The function indicator End time  lights up.

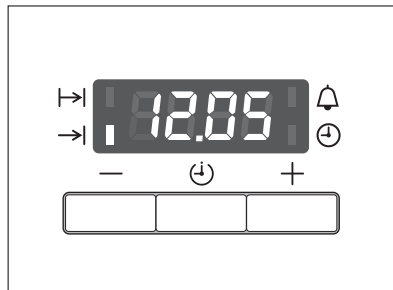

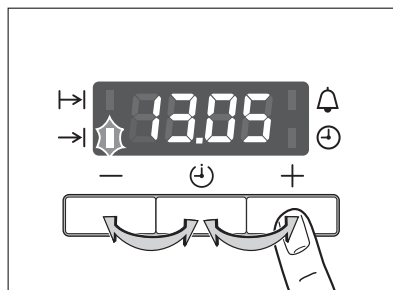

When the time has elapsed, the function indicator flashes, an audible signal sounds for 2 minutes and the oven switches itself off.

3. The signal and the programme can be stopped by pressing any button.



Cook time and End time combined



Cook time  and End time  can be used simultaneously, if the oven is to be switched on and off automatically **at a later time**.

1. Using the Cook time  function, set the time required for cooking the dish.

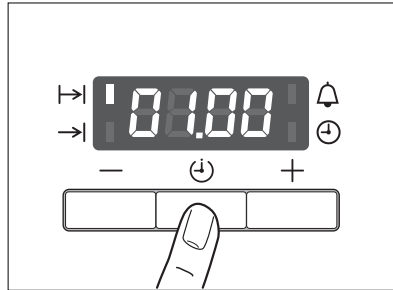

In this example, 1 hour.

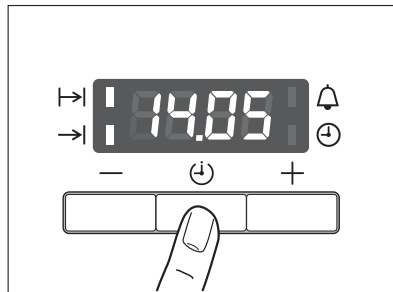

2. Using the End time  function, set the time at which the dish should be ready.

In this case 14:05:00.



The function indicators Cook time  and End time  light up and the current time is shown in the display.

In this case 12:05.

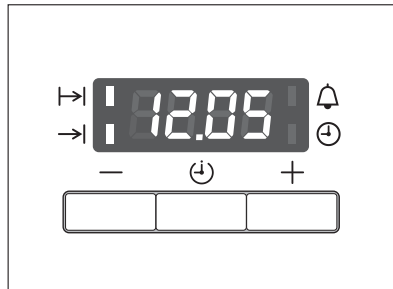

The oven switches on automatically at the time calculated.

In this case, at 13:05:00.

And switches itself off again when the cooking time entered has elapsed.

In this case, at 14:05.

Mechanical Door Lock

When the appliance is delivered, the door lock is deactivated.

Activate the door lock

Pull the safety catch forwards until it locks in place.

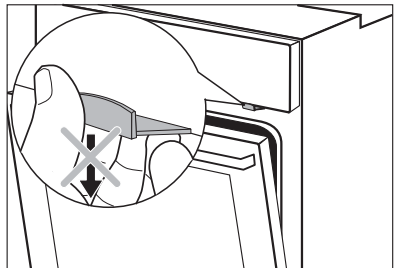
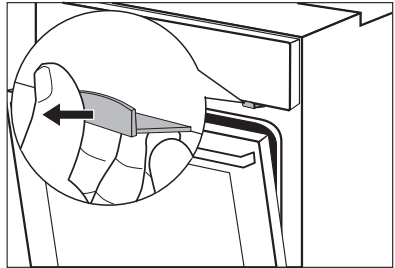

Open the oven door:

1. Shut the door.
2. Press the safety catch and keep it depressed.
3. Open the doors.

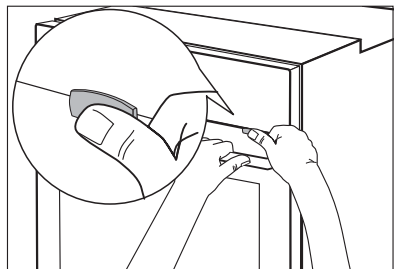

Close the oven door

Close the door without pressing the safety catch.

Deactivating the door lock

Press the safety catch back into the panel.



Switching off the appliance does not cancel the mechanical door lock.

Uses, Tables and Tips

Cooking table

The information given in the following table is for guidance only.

Heat setting	Cooking-process	suitable for	Cooking time	Tips/Hints
0		Residual heat, Off position		
1	Keeping food warm	Keeping cooked foods warm	as required	Cover
1-2	Melting	Hollandaise sauce, melting butter, chocolate, gelatine	5-25 mins.	Stir occasionally
	Solidifying	Fluffy omelettes, baked eggs	10-40 mins.	Cook with lid on
2-3	Simmering on low heat	Simmering rice and milk-based dishes Heating up ready-cooked meals	25-50 mins.	Add at least twice as much liquid as rice, stir milk dishes part way through cooking
3-4	Steaming Braising	Steaming vegetables, fish braising meat	20-45 mins.	With vegetables add only a little liquid (a few tablespoons)
4-5	Boiling	Steaming potatoes	20-60 mins.	Use only a little liquid, e. g.: max. 1/4 l water for 750 g potatoes
		Cooking larger quantities of food, stews and soups	60-150 mins.	Up to 3 l liquid plus ingredients
6-7	Gentle Frying	Frying escalopes, veal cordon bleu, cutlets, rissoles, sausages, liver, roux, eggs, pancakes, doughnuts	Steady frying	Turn halfway through cooking
7-8	Heavy Frying	Hash browns, loin steaks, steaks, Flädle (pancakes for garnishing soup)	5-15 mins. per pan	Turn halfway through cooking
9	Boiling Searing Deep frying	Boiling large quantities of water, cooking pasta, searing meat (goulash, pot roast), deep frying chips		



We recommend when boiling or searing foods using the highest heat setting at first and then letting foods requiring a longer cooking time finish cooking on the desired heat setting.





Overheated fats and oils can ignite quickly. If you are cooking foods in fat or oil (e.g. chips), remain nearby.



Baking

Oven function: Fan-assisted circulation  or Conventional 

Baking tins

- For Conventional , dark metal and non-stick tins are suitable.
- For Fan-assisted circulation  bright metal tins are also suitable.

Oven levels

- Baking with Conventional  is only possible on one level.
- With Fan-assisted circulation  you can bake dry cakes and biscuits on 2 baking trays at the same time.

1 baking tray:
e.g. oven level 3

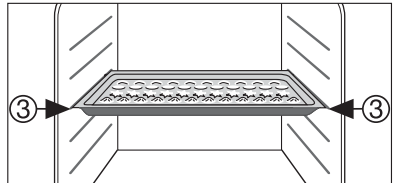

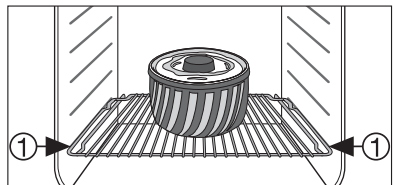

1 cake tin:
e.g. oven level 1

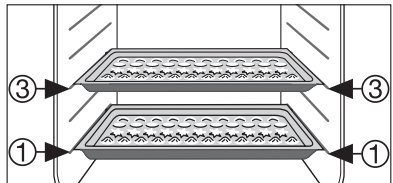

2 baking trays:
e. g. oven levels 1 and 3



General Instructions

- Insert the tray with the bevel at the front.
- With Conventional  or Fan-assisted circulation  you can also bake with two tins next to one another on the oven shelf at the same time. This does not significantly increase baking time.



When frozen foods are used the trays inserted may distort during cooking. This is due to the large difference in temperature between the freezing temperature and the temperature in the oven. Once the trays have cooled the distortion will disappear again.

How to use the Baking Tables

The tables give the required temperature settings, baking times and oven shelf levels for a selection of typical dishes.



















- Temperatures and baking times are for guidance only, as these will depend on the consistency of pastry or mixture, the number and the type of cake tin.
- We recommend using the lower temperature the first time and then if necessary, for example, if a deeper browning is required, or baking time is too long, selecting a higher temperature.
- If you cannot find the settings for a particular recipe, look for the one that is most similar.
- If baking cakes on baking trays or in tins on more than one level, baking time can be extended by 10–15 minutes.
- Moist recipes (for example, pizzas, fruit flans, etc.) are baked on one level.
- Cakes and pastries at different heights may brown at an uneven rate at first. If this occurs, **please do not change the temperature setting**. Different rates of browning even out as baking progresses.

























With longer baking times, you can switch the oven off about 10 minutes before the end of the baking time, in order to utilise the residual heat.

Unless otherwise stated, the values given in the tables assume that cooking is started with the oven cold.

Baking table

Type of baking	Ovenfunction	Shelf position	Temperature °C	Time Hours mins.	
Baking in tins					
Ring cake or brioche		Fan-assisted circulation	1	150-160	0:50-1:10
Madeira cake/Fruitcakes		Fan-assisted circulation	1	140-160	1:10-1:30
Sponge cake		Fan-assisted circulation	1	140	0:25-0:40
Sponge cake		Conventional	1	160	0:25-0:40
Flan base - short pastry		Conventional	3	180-200	0:10-0:25
Flan base - sponge mixture		Fan-assisted circulation	3	150-170	0:20-0:25
Apple pie		Conventional	1	170-190	0:50-1:00
Apple pie (2 tins Ø20cm, diagonally off set)		Fan-assisted circulation	1	160	1:10-1:30
Apple pie (2 tins Ø20cm, diagonally off set)		Conventional	1	180	1:10-1:30
Savoury flan (e. g. quiche lorraine)		Conventional	1	180-200	0:30-1:10
Cheesecake		Conventional	1	170-190	1:00-1:30
Cakes/pastries/breads on baking trays					
Plaited bread/bread crown		Conventional	3	170-190	0:30-0:40
Christmas stollen		Conventional	3	160-180 ¹⁾	0:40-1:00
Bread (rye bread) -first of all -then		Conventional	1	250 ¹⁾ 160-180	0:20 0:30-1:00
Cream puffs/Eclairs		Fan-assisted circulation	3	160-170 ¹⁾	0:15-0:30
Swiss roll		Conventional	3	180-200 ¹⁾	0:10-0:20
Cake with crumble topping(dry)		Fan-assisted circulation	3	150-160	0:20-0:40
Buttered almond cake/sugar cakes		Conventional	3	190-210 ¹⁾	0:15-0:30

Type of baking	Ovenfunction	Shelf position	Temperature °C	Time Hours mins.
Fruit flans (made with yeast dough/sponge mixture) ²⁾	 Fan-assisted circulation	3	150	0:35-0:50
Fruit flans (made with yeast dough/sponge mixture)	 Conventional	3	170	0:35-0:50
Fruit flans made with short pastry	 Conventional	3	170-190	0:40-1:20
Yeast cakes with delicate toppings (e. g. quark, cream, vanilla cream)	 Conventional	3	160-180	0:40-1:20
Pizza (with a lot of topping) ²⁾	 Conventional	1	190-210 ¹⁾	0:30-1:00
Pizza (thin crust)	 Conventional	1	230-250 ¹⁾	0:10-0:25
Unleavened bread	 Conventional	1	250-270	0:08-0:15
Tarts (CH)	 Conventional	1	200-220	0:35-0:50
Biscuits				
Short pastry biscuits	 Fan-assisted circulation	3	150-160	0:06-0:20
Short pastry biscuits	 Fan-assisted circulation	1 / 3	150-160	0:06-0:20
Viennese whirls	 Fan-assisted circulation	3	140	0:20-0:30
Viennese whirls	 Fan-assisted circulation	1 / 3	140	0:25-0:40
Viennese whirls	 Conventional	3	160 ¹⁾	0:20-0:30
Biscuits made with sponge mixture	 Fan-assisted circulation	3	150-160	0:15-0:20
Biscuits made with sponge mixture	 Fan-assisted circulation	1 / 3	150-160	0:15-0:20
Pastries made with egg white, meringues	 Fan-assisted circulation	3	80-100	2:00-2:30
Macaroons	 Fan-assisted circulation	3	100-120	0:30-0:60
Biscuits made with yeast dough	 Fan-assisted circulation	3	150-160	0:20-0:40
Puff pastries	 Fan-assisted circulation	3	170-180 ¹⁾	0:20-0:30

Type of baking	Ovenfunction	Shelf position	Temperature °C	Time Hours mins.
Rolls	 Fan-assisted circulation	3	160 ¹⁾	0:20-0:35
Rolls	 Conventional	3	180 ¹⁾	0:20-0:35
Small cakes (20 per tray)	 Fan-assisted circulation	3	140 ¹⁾	0:20-0:30
Small cakes (20 per tray)	 Fan-assisted circulation	1 / 4	140 ¹⁾	0:25-0:40
Small cakes (20 per tray)	 Conventional	3	170 ¹⁾	0:20-0:30







1) Pre-heat the oven

2) Use the drip tray or roasting tray

Tips on baking





Baking results	Possible cause	Remedy
The cake is not browned enough at the bottom	Wrong oven level	Place cake lower in the oven
The cake sinks (becomes soggy, lumpy, streaky)	Oven temperature too high	Use a slightly lower setting
	Baking time too short	Set a longer baking time Baking times cannot be reduced by setting higher temperatures
	Too much liquid in the mixture	Use less liquid Pay attention to mixing times, especially if using mixing machines
Cake is too dry	Oven temperature too low	Set oven temperature higher
	Baking time too long	Set a shorter baking time
Cake browns unevenly	Oven temperature too high and baking time too short	Set a lower oven temperature and a longer baking time
	Mixture is unevenly distributed	Spread the mixture evenly on the baking tray
Cake is not done within the baking time given	Temperature too low	Use a slightly higher oven setting

Table for Bakes and Gratins

Dish	Oven function	Shelf position	Temperature °C	Time Hours mins.	
Pasta bake		Conventional	1	180-200	0:45-1:00
Lasagne		Conventional	1	180-200	0:25-0:40
Vegetables au gratin ¹⁾		Rotitherm	1	160-170	0:15-0:30
Baguettes topped with melted cheese ¹⁾		Rotitherm	1	160-170	0:15-0:30
Sweet bakes		Conventional	1	180-200	0:40-0:60
Fish bakes		Conventional	1	180-200	0:30-1:00
Stuffed vegetables		Rotitherm	1	160-170	0:30-1:00

1) Pre-heat the oven

Frozen Ready Meals Table

Food to be cooked	Oven function	Shelf position	Temperature °C	Time	
Frozen pizza		Conventional	3	as per manufacturer's instructions	as per manufacturer's instructions
Chips ¹⁾ (300-600 g)		Rotitherm	3	200-220	15-25 mins.
Baguettes		Conventional	3	as per manufacturer's instructions	as per manufacturer's instructions
Fruit flans		Conventional	3	as per manufacturer's instructions	as per manufacturer's instructions

1) Comments: Turn chips 2 or 3 times during cooking

Roasting

Oven function: Conventional  or Rotitherm 

Roasting dishes

- Any heat-resistant ovenware is suitable to use for roasting (please read the manufacturer's instructions).
- Large roasting joints can be roasted **directly in the roasting tray or on the oven shelf with the roasting tray placed below it.**
- For all lean meats, we recommend **roasting these in a roasting tin with a lid.** This will keep the meat more succulent.
- All types of meat, that can be browned or have crackling, can be roasted in the **roasting tin without the lid.**

























Tips on using the roasting chart

The information given in the following table is for guidance only.

- We recommend cooking meat and fish **weighing 1 kg and above in the oven.**
- To prevent escaping meat juices or fat from burning on to the pan, we recommend placing some liquid in the roasting pan.
- If required, turn the roast (after 1/2 - 2/3 of the cooking time).
- Baste large roasts and poultry with their juices several times during roasting. This will give better roasting results.
- You can switch the oven off about 10 minutes before the end of the roasting time, in order to utilise the residual heat.

Roasting table

Type of meat	Quantity	Ovenfunction	Shelf position	Temperature °C	Time Hours mins.	
Beef						
Pot roast	1-1.5 kg		Conventional	1	200-250	2:00-2:30
Roast beef or fillet						per cm. of thickness
- rare	per cm. of thickness		Rotitherm	1	190-200 ¹⁾	0:05-0:06
- medium	per cm. of thickness		Rotitherm	1	180-190	0:06-0:08
- well done	per cm. of thickness		Rotitherm	1	170-180	0:08-0:10
Pork						
Shoulder, neck, ham joint	1-1.5 kg		Rotitherm	1	160-180	1:30-2:00
Chop, spare rib	1-1.5 kg		Rotitherm	1	170-180	1:00-1:30
Meat loaf	750 g-1 kg		Rotitherm	1	160-170	0:45-1:00
Porkknuckle (pre-cooked)	750 g-1 kg		Rotitherm	1	150-170	1:30-2:00
Veal						
Roast veal	1 kg		Rotitherm	1	160-180	1:30-2:00
Knuckle of veal	1.5-2 kg		Rotitherm	1	160-180	2:00-2:30
Lamb						
Leg of lamb, roast lamb	1-1.5 kg		Rotitherm	1	150-170	1:15-2:00
Saddle of lamb	1-1.5 kg		Rotitherm	1	160-180	1:00-1:30
Game						
Saddle of hare, leg of hare	up to 1 kg		Conventional	3	220-250 ¹⁾	0:25-0:40
Saddle of venison	1.5-2 kg		Conventional	1	210-220	1:15-1:45
Haunch of venison	1.5-2 kg		Conventional	1	200-210	1:30-2:15

Type of meat	Quantity	Ovenfunction	Shelf position	Temperature °C	Time Hours mins.	
Poultry						
Poultry portions	200-250g each		Rotitherm	1	200-220	0:35-0:50
Half chicken	400-500g each		Rotitherm	1	190-210	0:35-0:50
Chicken, poulard	1-1.5 kg		Rotitherm	1	190-210	0:45-1:15
Duck	1.5-2 kg		Rotitherm	1	180-200	1:15-1:45
Goose	3.5-5 kg		Rotitherm	1	160-180	2:30-3:30
Turkey	2.5-3.5 kg		Rotitherm	1	160-180	1:45-2:30
	4-6 kg		Rotitherm	1	140-160	2:30-4:00
Fish (steamed)						
Whole fish	1-1.5 kg		Conventional	1	210-220	0:45-1:15

1) Pre-heat the oven

Grill Sizes

Oven function: Grill  or Dual grill  with maximum temperature setting



Important: Always grill with the oven door closed.



The empty oven should **always be pre-heated with the grill functions for 5 minutes.**

- For grilling, place the **shelf** in the **recommended shelf position.**
- Always insert the **tray for collecting the fat** into the **first shelf position** from the bottom.
- The grilling times are guidelines.
- Grilling is particularly suitable for flat pieces of meat or fish.

Grilling table

Food to be grilled	Oven level	Grilling time	
		1st side	2nd side
Burgers	4	8-10 mins.	6-8 mins.
Pork fillet	4	10-12 mins.	6-10 mins.
Sausages	4	8-10 mins.	6-8 mins.
Fillet steaks, veal steaks	4	6-7 mins.	5-6 mins.
Fillet of beef, roast beef (approx. 1 kg)	3	10-12 mins.	10-12 mins.
Toast ¹⁾	3	4-6 mins.	3-5 mins.
Toast with topping	3	6-8 mins.	---

1) Do not pre-heat

Defrosting

Oven function: Defrost  (no temperature setting)

- Unwrap the food and place it on a plate on the oven shelf.
- Do not cover with a plate or bowl, as these can substantially lengthen the defrosting time.
- For defrosting, place the shelf in the **1st oven level from the bottom**.

Defrosting table

Dish	Defrosting time mins.	Further defrosting time (mins.)	Comments
Chicken, 1000 g	100-140	20-30	Place the chicken on an upturned saucer placed on a large plate Turn halfway through
Meat, 1000 g	100-140	20-30	Turn halfway through
Meat, 500 g	90-120	20-30	Turn halfway through
Trout, 150g	25-35	10-15	---
Strawberries, 300g	30-40	10-20	---
Butter, 250g	30-40	10-15	---
Cream, 2 x 200g	80-100	10-15	Cream can also be whipped when still slightly frozen in places
Gateau, 1400g	60	60	---

Drying

Oven function: Fan-assisted circulation

- Use oven shelves covered with greaseproof paper or baking parchment.
- You get a better result if you switch the oven off halfway through the drying time, open the door and leave the oven to cool down overnight.
- After this finish drying the food to be dried.

Food to be dried	Temperature in °C	Oven level		Time in hours (Guideline)
		1 level	2 levels	
Vegetables				
Beans	60-70	3	1 / 4	6-8
Peppers (strips)	60-70	3	1 / 4	5-6
Vegetables for soup	60-70	3	1 / 4	5-6
Mushrooms	50-60	3	1 / 4	6-8
Herbs	40-50	3	1 / 4	2-3
Fruit				
Plums	60-70	3	1 / 4	8-10
Apricots	60-70	3	1 / 4	8-10
Apple slices	60-70	3	1 / 4	6-8
Pears	60-70	3	1 / 4	6-9

Making Preserves

Oven function: Bottom heat

- For preserving, use only commercially available preserve jars of the same size.
- **Jars with twist-off or bayonet type lids and metal tins are not suitable.**
- When making preserves, the **first shelf position from the bottom** is the one most used.
- Use the shelf for making preserves. There is enough room on this for up to six 1-litre preserving jars.
- The jars should all be filled to the same level and clamped shut.
- Place the jars on the baking tray in such a way that they are not touching each other.
- Pour approx. 1/2 litre of water into the baking tray so that sufficient moisture is produced in the oven.
- As soon as the liquid starts to pearl in the first jars (after about 35-60 minutes with 1 litre jars), switch the oven off or reduce the temperature to 100°C (see table).

Preserves table

The times and temperatures for making preserves are for guidance only.

Preserve	Temperature in °C	Cooking time until simmering in mins.	Continue to cook at 100°C in mins.
Soft fruit			
Strawberries, blueberries, raspberries, ripe gooseberries	160-170	35-45	---
Unripe gooseberries	160-170	35-45	10-15
Stone fruit			
Pears, quinces, plums	160-170	35-45	10-15
Vegetables			
Carrots ¹⁾	160-170	50-60	5-10
Mushrooms ¹⁾	160-170	40-60	10-15
Cucumbers	160-170	50-60	---
Mixed pickles	160-170	50-60	15
Kohlrabi, peas, asparagus	160-170	50-60	15-20
Beans	160-170	50-60	---

1) Leave standing in oven when switched off

Cleaning and Care



Warning: For cleaning, the appliance must be switched off and cooled down.

Warning: For safety reasons, **do not** clean the appliance with steam jet or high-pressure cleaning equipment.

Attention: **Do not use any scouring agents, sharp cleaning tools or scourers.**

Outside of the appliance

- Wipe the front of the appliance with a soft cloth and warm water and washing up liquid.
- For metal fronts, use normal commercially available cleaning agents.

Oven interior

Clean the appliance after each use. In this way, dirt is easier to clean off and is not allowed to burn on.

1. For cleaning, turn the oven light on.
2. After every use, wipe the oven with a solution of washing-up liquid and allow to dry.



Clean stubborn dirt with a special oven cleaner.



Important: If using an oven spray, please follow the manufacturer's instructions exactly.

Accessories

Wash all slide-in units (shelf unit, baking tray, shelf support rails etc.) after each use and dry well. Soak briefly to make them easier to clean.

Non-stick accessories

Clean accessories with a soft sponge or cloth in hot water and washing-up liquid.



Bright spots in the coating do not mean that the surface is damaged.



Important: **Do not use any aggressive or scouring cleaning agents, spray oven cleaners, steel soap pads or hard objects such as knives or sharp-edged scrapers. These destroy the coating.**



Important: **Do not clean these accessories in the dishwasher.** The non-stick properties would be lost as a result.

Shelf Support Rails

The shelf support rails on the left and right hand sides of the oven can be removed for cleaning the side walls.

Removing the shelf support rails

First pull the front of the rail away from the oven wall (1) and then un-hitch at the back (2).

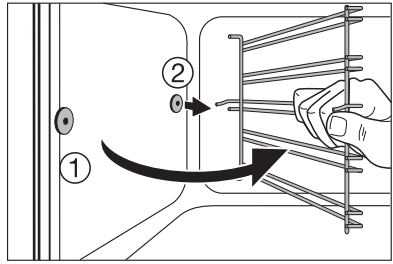
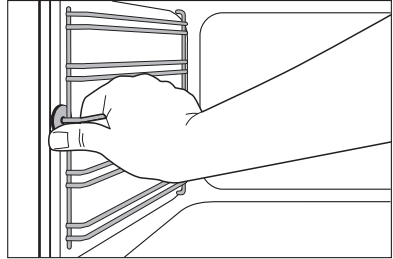

Fitting the shelf support rails



Important! The rounded ends of the guide rails must be pointing forwards!

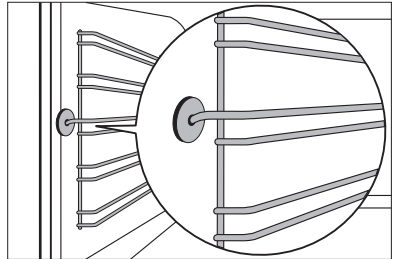

To re-insert, first hook the rail into place at the back (1) and then insert the front and press into place (2).

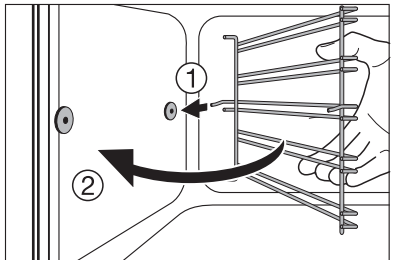

Oven Lighting



Warning: There is a danger of electric shock! Prior to changing the oven light bulb:

- Switch off the oven!
- Remove the fuses in the fuse box or switch off the circuit breaker.



Place a cloth on the oven floor to protect the oven light and glass cover.

Replacing the oven light bulb/ cleaning the glass cover

1. Remove the glass cover by turning it anti-clockwise and then clean it.
2. If necessary:
**Replace bulb with a 40 watt,
230 V, 300 °C heat-resistant
oven light bulb.**
3. Refit the glass cover.

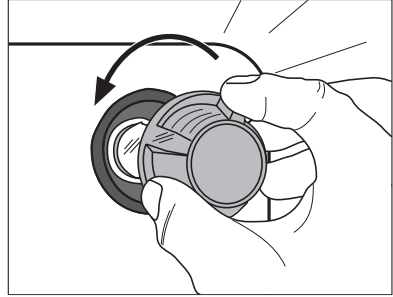

Oven Ceiling

The upper heating element can be folded down to make it easier to clean the oven ceiling.

Folding down the heating element



Warning: Only fold down the heating element when the oven is switched off and there is no risk of being burnt!

1. Remove the side shelf support rails.
2. Grip the heating element at the front and pull it forwards and out over the support lug on the inner wall of the oven.
3. The heating element will now fold down.



Caution: Do not use force to press the heating element down! The heating element might break.

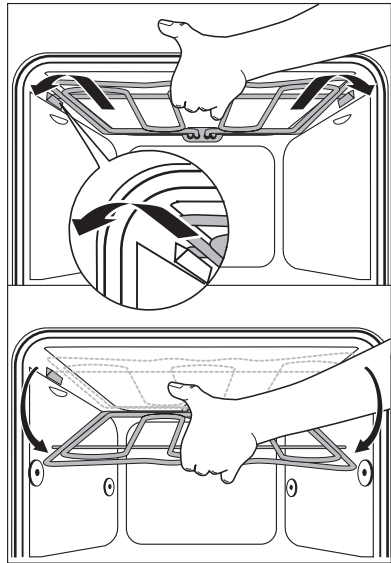

Cleaning the oven ceiling

Repositioning the heating element

1. Move the heating element back up towards the oven ceiling.
2. Pull the heating element forwards against the spring pressure and guide it over the oven support lug.
3. Settle it onto the support.
4. Insert shelf support rail.



Important: The heating element must be positioned correctly and securely on both sides above the support lug on the inner wall of the oven.

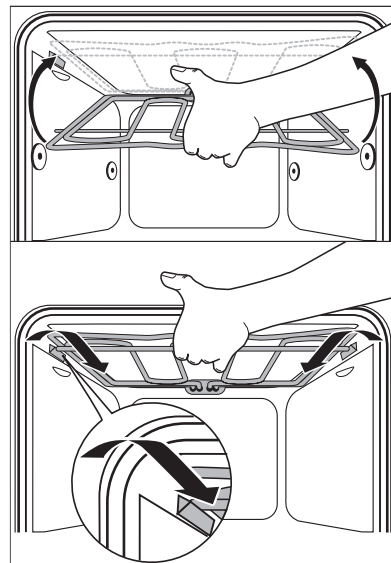

Oven door

For easier cleaning of the oven interior the oven door of your appliance can be taken off its hinges.

Removing the oven door from its hinges

1. Open the oven door as far as it will go.

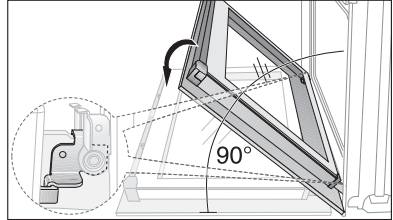

2. Undo the **clamping levers (A)** on both door hinges **fully**.

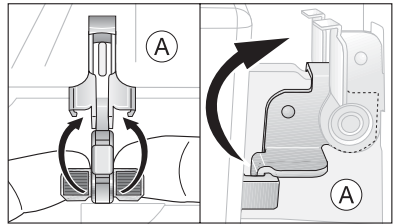

3. Close the oven door as far as the first position (approx. 45°).

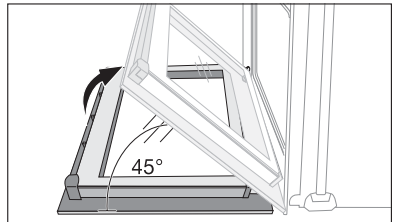

4. Take hold of the oven door with a hand on each side and pull it away from the oven at an upwards angle (**Take care:** It is heavy).

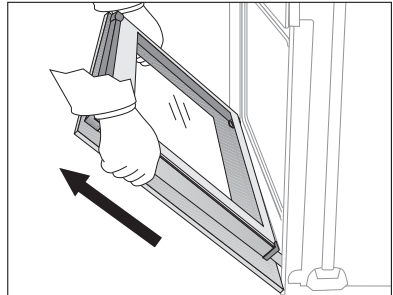

Lay the oven door with the outer side facing downwards on something soft and level, for example, a blanket in order to prevent scratches.

Hanging the oven door back on its hinges

1. From the handle side take hold of the oven door with a hand on each side and hold at an angle of approx. 45°.

Position the recesses on the bottom of the oven door on the hinges on the oven.

Let the door slide down as far as it will go.

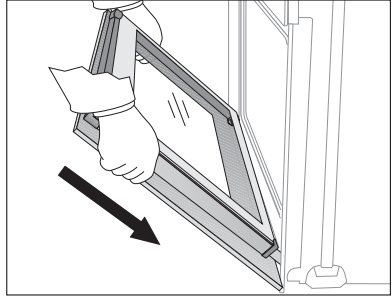

2. Open the oven door as far as it will go.

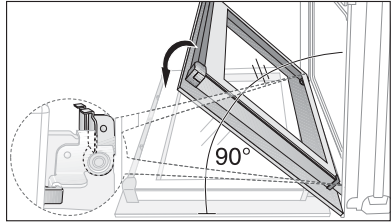

3. Fold up the clamping levers (A) on both door hinges back into their original positions.

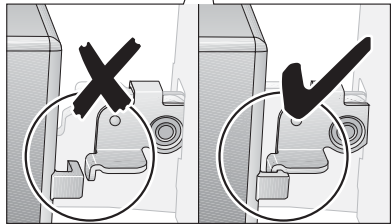
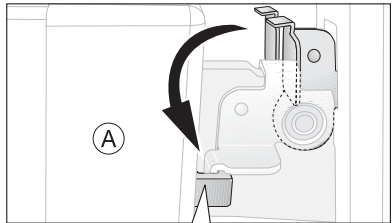

4. Close the oven door.

Oven door glass

The oven door is fitted with three panels of glass mounted one behind the other. The inner panels can be removed for cleaning.



Important! Rough handling, especially around the edges of the front panel, can cause the glass to break.

Removing the door glass panels

1. Open the oven door as far as it will go.

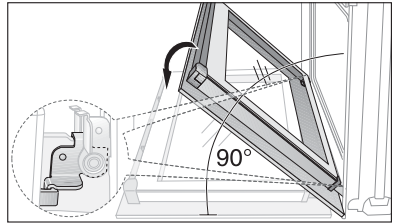

2. Undo the **clamping levers (A)** on **both door hinges** fully

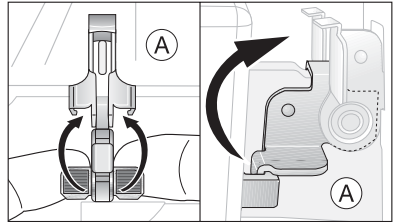

3. Close the oven door as far as the first position (approx. 45°).

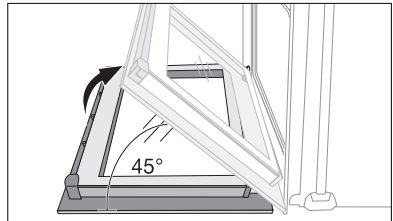

4. Take hold of the door trim (B) on the upper edge of the door at both sides and press inwards to release the clip seal. Then remove the door trim by pulling it upwards.

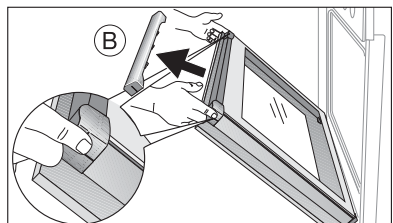

5. Take hold of the door glass panels on their upper edge one after the other and take them out of the guide by pulling them upwards..

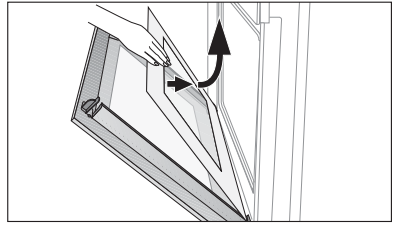

Cleaning the door glass panels

Clean the door glass panels thoroughly with a solution of water and washing up liquid. Then dry them carefully

Putting the door glass panels back.

1. From above insert the door glass panels at an angle into the door profile at the bottom edge of the door one after the other and lower them.

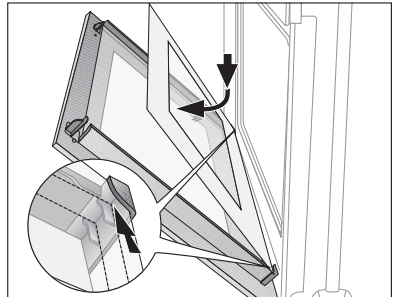

Insert the smaller panel first, then the larger panel.

2. Take hold of the door trim (B) at each side, position it on the inside edge of the door and plug the door trim (B) into the upper edge of the door

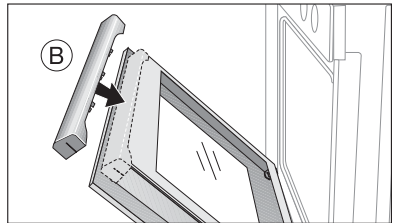



On the open side of the door trim (B) there is a guide bar (C). This must be pushed ~~This must be pushed~~ **between** the outer door panel and the guide corner (D). The clip seal (E) must be snapped in.

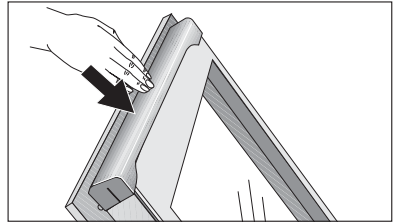
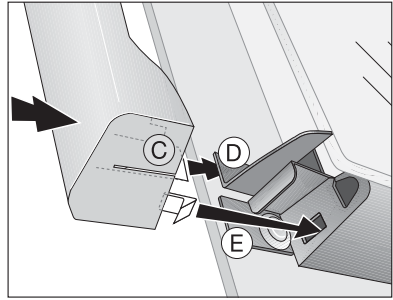

3. Open the oven door as far as it will go

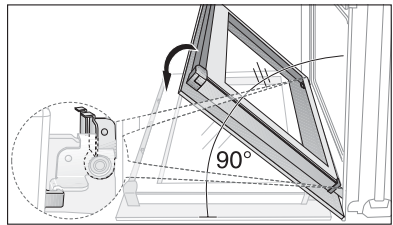

4. Fold up the clamping levers (A) on both door hinges back into their original positions

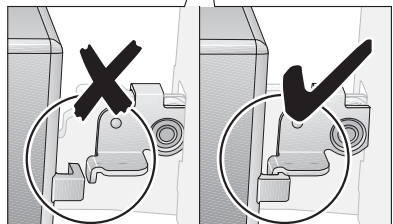
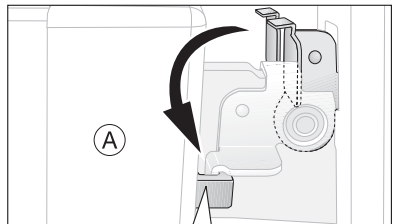

5. Close the oven door.

What to do if ...

Problem	Possible cause	
The cooking zones are not functioning	Consult the operating instructions for the built-in cooking surface	
The oven does not heat up	The oven is not switched on	Switch the oven on
	The clock is not set	Set the current time on the clock
	The required settings have not been set	Check the settings
	The house wiring fuse (in the fuse box) has tripped	Check the fuse. If the fuses trip a number of times, please call an authorised electrician.
The oven lighting is not operating	The oven light bulb is faulty	Replace the oven bulb

If you are unable to remedy the problem by following the above suggestions, please contact your dealer or the Customer Care Department.



Warning! Repairs to the appliance are only to be carried out by qualified service engineers. Considerable danger to the user may result from improper repairs.



If the appliance has been wrongly operated, the visit from the customer service technician or dealer may not take place free of charge, even during the warranty period.



Advice on cookers with metal fronts:

Because of the cold surface at the front of the cooker, opening the oven door during (or just after) baking or roasting may cause the glass to steam up.

Service

In the event of technical faults, please first check whether you can remedy the problem yourself with the help of the operating instructions (section "What to do if...").

If you were not able to remedy the problem yourself, please contact the Customer Care Department or one of our service partners.

In order to be able to assist you quickly, we require the following information:

- Model description
- Product number (PNC)
- Serial number (S No.)
(for numbers see rating plate)
- Type of fault
- Any error messages displayed by the appliance

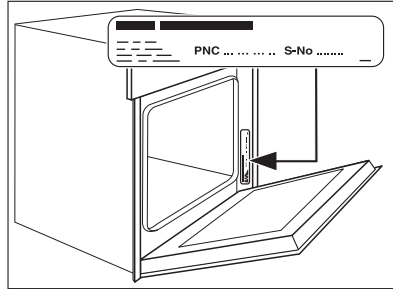

So that you have the necessary reference numbers from your appliance at hand, we recommend that you write them in here:

Model description:

PNC:

S No:

 **From the Electrolux Group. The world's No. 1 choice.**

The Electrolux Group is the world's largest producer of powered appliances for kitchen, cleaning and outdoor use. More than 55 million Electrolux Group products (such as refrigerators, cookers, washing machines, vacuum cleaners, chain saws and lawn mowers) are sold each year to a value of approx. USD 14 billion in more than 150 countries around the world.

AEG Hausgeräte GmbH
Postfach 1036
D-90327 Nürnberg

<http://www.aeg-electrolux.de>

© Copyright by AEG

822 927 565-A-210306-02

Subject to change without notice