

Protectowire Linear Heat Detector

*Installation,
Operation &
Maintenance
Manual*



PROTECTOWIRE
FireSystems

Forward

At the present time there is no code or recommended standards in the United States specifically covering system design requirements for Linear Heat Detection Systems. In the past, information pertinent to designing this type of system has been difficult to locate and generally based upon existing requirements for spot heat detection devices.

In view of these factors, this manual has been designed to outline basic principles which should be utilized in the design and layout of a Protectowire Linear Heat Detection System. These principles are based upon years of system design experience as well as nationally recognized code requirements or approval agency standards. In addition, these principles recognize the operating characteristics of the Protectowire detector and the environmental factors which may either aid or hinder its operation.

It is important to realize that codes, standards and other relevant material which may have been used in preparing this manual, are dynamic documents which are subject to change over time. We have made a conscientious effort to ensure that all references in this manual which pertain to outside approvals, regulatory requirements, codes or standards are current and as up-to-date as possible. However, we recommend that in applications where a specific code requirement or installation standard is required, the Authority Having Jurisdiction (AHJ) be consulted to ensure compliance. In all cases, local codes or installation requirements as stipulated or approved by the AHJ shall take priority.

Contents

<u>Section</u>	<u>Page</u>
Introduction	1
Product Description	1
How It Works	2
Electrical Arrangement	2
Maximum Copper Feed Cable Length (Table 1)	3
General Principles.....	3
Temperature Ratings	4, 5
Detector Location and Spacing	5
Protectowire Model Numbers and Maximum Listed Spacing	6
Pre-Action Sprinkler Systems	8
Environmental Considerations.....	9
PWS Splicing Sleeves	10
PWSC Splicing Connectors.....	11
Installation Detail	11
Fasteners	11
General Purpose	11
Cable Trays	14
Pipe Mounting	15
Messenger Wire	15
Installation Warnings	16
Special Application Installations	17
Cable Trays	17
Conveyors.....	18
Power Distribution Apparatus	19
Dust Collectors/Baghouses	19
Open Rack Storage.....	20
Floating Roof Tanks	20
Refrigerated Storage Areas.....	21
Tunnels	22
Self-Storage Warehouses	23
Inspection and Testing	23
Protectowire Test Equipment.....	24
Conversion Factors	25
Chemical Resistant Chart for Protectowire Jacket Materials EPC, TRI, XLT, EPR.....	26
Chemical Resistant Chart for Protectowire Jacket Material XCR	27

Introduction

Since The Protectowire Company introduced the first Linear Type Heat Detector in the United States over 70 years ago, this type of detector, with its unique characteristics, has been employed in applications where it has proven to be a highly reliable form of fire detection.

The construction and operating principles of the various linear heat detectors that are available today, can with few exceptions, be classified in the following major categories:

Analog (Integrating) Linear Type Heat Detectors -

These detectors are composed of sensing elements whose response to temperature is summed in some way along the length of the entire cable. The resistance of the insulation between the conductors is monitored by a control unit which may have adjustable alarm threshold settings.

Typically, as the temperature of the cable increases, the wire's resistance will decrease. When the preset alarm threshold is reached an alarm condition is signaled by the control unit.

Digital Linear Type Heat Detectors -

Digital type detectors, such as Protectowire, consist of sensing elements which respond to a specific temperature at any point along their length. The inner conductors are coated with a polymer that melts at a predetermined temperature which allows the conductors to make contact with one another and thereby signal an alarm condition.

While several other types of sensing technologies, such as fiber optics and pressurized pneumatic tubing are also in use, the two product categories stated above are the most widely used today.

The present NFPA 72 National Fire Alarm and Signaling Code, provides basic information on the application of linear heat detectors such as location and spacing distances for area protection. The ability to correctly engineer the application of these detectors to special hazards, however, is provided mainly by the manufacturers who have developed this technology and expertise over the years.

In view of these factors, the purpose of this manual is to ensure that coverage of the area to be protected is in accordance with accepted fire protection principles and to provide uniform installation guidance. Whenever there is a choice between two or more possible procedures, the one which results in increased protection should be followed. Also discussed will be the operating characteristics of the Protectowire sensor and the environmental factors which may influence its operation.

Product Description

Protectowire Linear Heat Detector is comprised of two steel conductors individually encased in a heat sensitive polymer. The encased conductors are twisted together to impose a spring pressure between them, then spirally wrapped with a protective tape and finished with an outer jacket to suit the installation environment.

The Detector's current product range consists of five distinct types of cable. Each designation identifies a specific model type and outer jacket material which has unique characteristics that have been selected to accommodate the widest range of installation environments.

EPC - Type EPC consists of a durable vinyl outer jacket. This series is best described as multipurpose and is well suited to a wide range of both commercial and industrial applications. The outer jacket provides good all-around performance for most installations. It features low moisture absorption, resistance to many common chemicals, excellent flexibility at low temperatures and is flame retardant.

EPR - The EPR series contains an extruded flame retardant polypropylene based jacket with a special UV stabilizer added to enhance weathering performance. It is intended for a wide range of industrial applications and is characterized by high resiliency, good abrasion resistance, excellent weathering properties, and good high temperature performance.

TRI - Protectowire Type TRI, (TRI-Wire™) is a unique dual temperature detector which is capable of initiating separate pre-alarm and

alarm signals once each of its rated activation temperatures are reached. The Detector consists of a durable vinyl outer jacket similar to Type EPC.

XCR - Type XCR utilizes a high performance fluoropolymer jacket. This detector is specifically designed for use in applications where extreme environmental and product performance criteria must be met. In general, the flame retardant, low smoke XCR jacket provides excellent abrasion resistance and mechanical properties over a broad range of temperatures. It provides excellent chemical and permeation resistance to a wide variety of acids, bases, and organic solvents as well as simple gases. In addition, the jacket exhibits very little change in tensile properties upon outdoor exposure to sunlight and weather.

XLT - Protectowire Type XLT is a unique detector that has been designed for use in cold storage facilities and other applications that require a low alarm activation temperature. The outer jacket is a proprietary flame retardant polymer that provides low moisture absorption, good chemical resistance and excellent low temperature performance. This detector has been UL and FM tested to -60°F (-51°C).

How It Works

At the rated operating temperature, the Detector's heat sensitive polymer insulation yields to the pressure upon it, permitting the inner conductors to move into contact with each other. This action takes place at the first heated point anywhere along the Detector's length. It does not require that any specified length be heated in order to initiate an alarm. Protectowire is a fixed temperature sensor and is therefore capable of initiating an alarm at any point along its length, once the rated actuation temperature is reached.

Electrical Arrangement

Since Protectowire has been approved as a heat actuated automatic fire detector, it is intended to be used on a supervised initiating circuit of an approved fire protective signaling control unit. The Detector must be installed

in continuous runs without taps or branches in accordance with applicable sections of NFPA 70 National Electrical Code, NFPA 72 National Fire Alarm and Signaling Code or as determined by the local authority having jurisdiction. Within the context of this manual, the word "approved" is defined as that which is "acceptable to the authority having jurisdiction." The authority having jurisdiction is defined as "the organization, office or individual responsible for approving equipment, an installation or a procedure." [From NFPA 72]

Typically, an initiating device circuit will be designated as Class A or B depending upon the circuits' ability to continue to transmit alarm and trouble signals during single circuit fault conditions defined as follows:

- Circuits capable of transmitting an alarm signal during a single open or ground fault, provided they do not occur simultaneously, are designed as Class A. In terms of an actual wiring configuration, this circuit typically consists of a pair of wires running from the control panel out through the hazard area, and returning in a continuous loop back to the control panel where they are terminated.
- Circuits not capable of transmitting an alarm beyond the location of the open or ground fault as specified above, are designated Class B. Class B circuits generally do not return to the control panel, but are terminated by an end-of-line device remote from the control panel.

In addition to the class designations described above, initiating device circuits may also be designated by Style. The Style designation is determined by the capability of the circuit to transmit alarm and trouble signals during specified multiple circuit fault conditions, in addition to the single circuit fault conditions designated by the circuits' class. For further details and a complete description of the performance capabilities of various initiating device circuits, please refer to NFPA 72.

Regardless of the Class or Style of the initiating device circuits specified, the basic wiring practices for the installation of Protectowire in each circuit remain the same. In general, the use of Protectowire in any initiating device circuit (zone), is limited to coverage of a specific hazard or area requiring protection.

Copper feed wire, of an approved type, with a minimum conductor size of 18 AWG, shall be installed from the control panel out to the hazard area where it is then connected to the beginning of the Protectowire portion of the circuit. To determine the recommended wire gauge size and maximum length of copper feed wire which may be used on each initiating circuit of a Protectowire FireSystem Control Panel, refer to Table 1.

The Protectowire portion of every initiating circuit shall terminate at each end in an approved zone box, end-of-line zone box, or other approved junction box provided as part of the system. Strain relief connectors, Series SR-502, shall be installed in all junction boxes where Protectowire enters or exits the enclosure, in order to hold the cable securely and maintain dust and moisture tight conditions. All zone box enclosures shall be rated and approved for use in the environment where they will be installed.

All electrical connections made within each zone box between Protectowire and the circuits' interconnecting copper wire or end of line device, shall be made via terminals. The Protectowire Company supplies zone boxes, identified by the letters QC, which contain a compression type terminal strip which allows the installer to directly connect Protectowire conductors to the terminals. In all other cases, PFL Flexible Leads must be used to connect Protectowire conductors to electrical terminals. PFL's consist of a twisted pair of soft copper wires each with a PWS Splicing Sleeve staked on one end, and insulated with slip-on vinyl tubing. One lead is secured to each conductor by bending as in making a PWS splice, and insulated and taped in the same way (See Figure 7A). The use of wire nuts or other similar wiring devices not specifically approved by The Protectowire Company, is not recommended and shall be considered a misapplication of the product.

Figures 1 and 1A depict the typical field wiring of a ZB-4-QC-MP Zone Box in a Class B detection circuit of a fire alarm system using Protectowire Linear Heat Detector. Figure 1B depicts the field wiring utilized in a Class A type detection circuit. It is important to note that in each case, Protectowire may be connected directly to the QC type terminals and

that all bends in the Detector should have a radius of not less than 2.5 inches (6.4 cm).

Maximum Copper Feed Cable Length vs. Wire Gauge (Diameter)		
For Protectowire FireSystem Initiating Circuits		
Initiating Circuits with Protectowire Alarm Point Location Meter (18 ohms offset)		
<u>AWG*</u>	<u>DIA.</u>	<u>MAX. LENGTH OF 2 CONDUCTOR CABLE</u>
#18	1.02 mm	1,360 feet (414 m)
#16	1.27 mm	2,200 feet (670 m)
#14	1.63 mm	3,500 feet (1,067 m)
#12	2.05 mm	5,500 feet (1,676 m)
Initiating Circuits Without Alarm Point Location Meter (Max. Resistance 100 ohms)		
<u>AWG*</u>	<u>DIA.</u>	<u>MAX. LENGTH OF 2 CONDUCTOR CABLE</u>
#18	1.02 mm	7,600 feet (2,316 m)
#16	1.27 mm	12,200 feet (3,719 m)
#14	1.63 mm	19,400 feet (5,913 m)
#12	2.05 mm	30,800 feet (9,388 m)
*American Wire Gauge		

Table 1

General Principles

Protectowire must be installed in continuous runs without taps or branches to comply with locations and spacing prescribed by the approving authorities. Except for zoning requirements (alarm source indication) the length of each run is limited, and controlled by the electrical characteristics of the control equipment to which the Detector is connected.

The Protectowire Company's FireSystem Control Panels have been specifically designed for compatible operation with Protectowire Linear Heat Detector. Each FireSystem Control Panel has been approved for operating Protectowire Linear Heat Detector, approved smoke detectors or a combination of the two devices on the same initiating circuit. The maximum quantity of detectors and length of sensor cable will vary based upon the specific control panel utilized. Please refer to the

Operation and Maintenance Manual provided with each system control panel for specific product information and limitations.

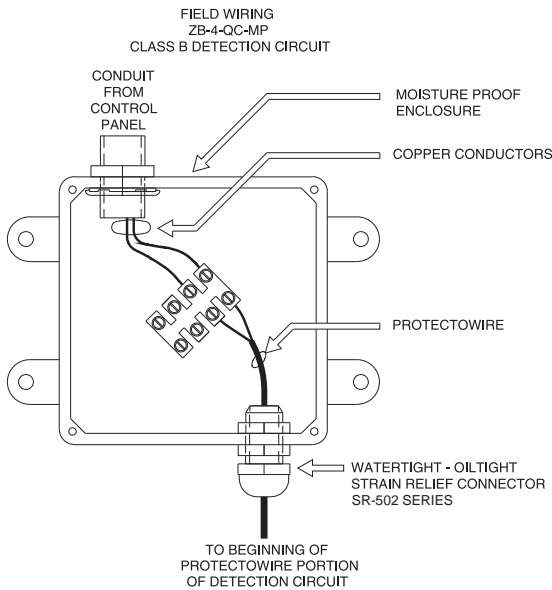

Figure 1

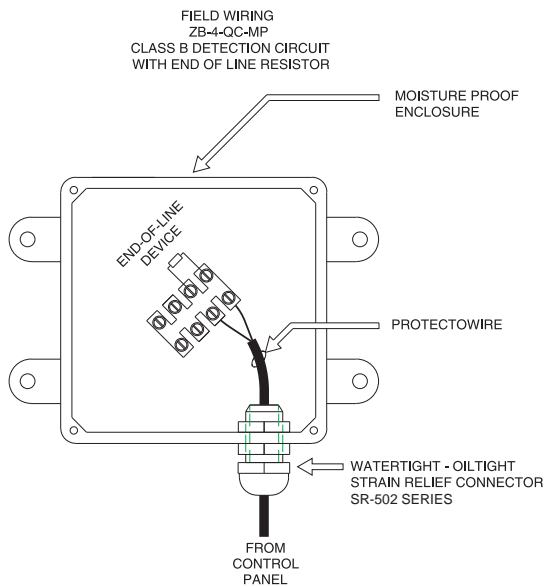

Figure 1A

When Protectowire is utilized on other manufacturer's control panels, several important factors must be considered:

- Protectowire operates like a normally open contact device which closes (shorts) upon activation. Therefore, it must be utilized only on initiating circuits which can detect and annunciate a contact closure (short) as an alarm condition.

FIELD WIRING
ZB-4-QC-MP
CLASS A DETECTION CIRCUIT

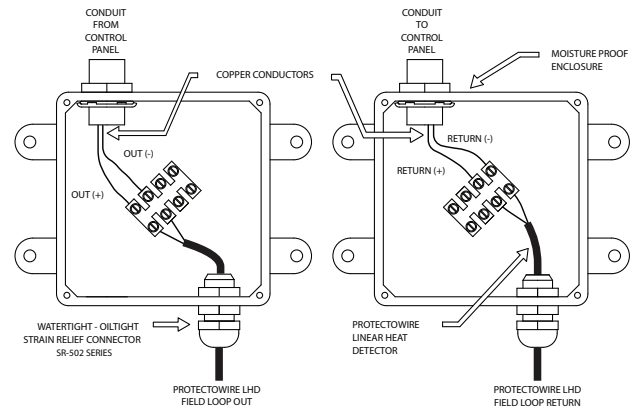

Figure 1B

- Protectowire is a **resistive contact device**, unlike traditional spot heat detectors which add little appreciable resistance to a detection circuit. The Detector's comparatively high resistance of 1 ohm for every 5 feet (1.5m) of twisted pair, make it necessary to evaluate each manufacturer's control panel and limit the Detector's length to ensure that each initiating circuit's specified resistance limitation is not exceeded. For most manufacturer's panels, the length of Protectowire which may be used on each circuit will be relatively short since the typical detection circuit is designed primarily to operate early warning smoke detectors.
- Applications in which long lengths of Protectowire are used on other manufacturer's control panels, can lead to situations where the control panel would indicate a constant "trouble" condition due to the excessively high circuit resistance, or create a situation whereby the initiating circuit would not be capable of latching into alarm. Caution must be taken when using Protectowire on other manufacturer's control panels to minimize the risk of compatibility problems.

Temperature Ratings

The Detector is made in different temperature ratings to allow for differences in normal or

“ambient” temperature. These ratings and their approximate temperature of operation are as follows:

Regular	135°F (57°C) 155°F (68°C)
Intermediate	190°F (88°C) 220°F (105°C)
High	280°F (138°C)
Extra High	356°F (180°C)

Rules for selecting the proper rating to be installed in a given area are the same as for automatic sprinklers and other heat actuated devices. The factors which must be considered are:

- What temperatures will the Detector be subjected to based upon the fire intensity characteristics of a particular fuel?
- What is the maximum ambient temperature at the Detector?

Please refer to the Temperature Rating and Model Number Chart for a detailed listing of each Protectowire model and its maximum installed ambient temperature limit.

The selection of the Detector rating should be based upon the most rapid response to the anticipated fire condition combined with the ability to withstand a high, but not abnormal ambient temperature, without causing an unwanted alarm. For example, Regular rating should not as a rule be put in an attic. In buildings such as sheds and warehouses with roofs exposed to the sun and inadequately insulated or ventilated, summer temperatures near the roof may be expected to rise well above 100°F (38°C) in many geographic areas. In an extremely hot climate, even Intermediate may be too sensitive for a poorly ventilated attic area or under an uninsulated metal roof.

In the same way, allowance must be made for normally high temperatures in boiler and heater rooms, under glass exposures, in areas where steam pipes or heating ducts are run, near unit heaters and heating outlets, and in all other locations where ceiling temperatures above 100°F (38°C) are not indicative of fire or other abnormal conditions.

The area in front of and within the air flow of

heating outlets and unit heaters should always be investigated. In freezer applications, locations near refrigeration equipment are also subject to surprisingly high temperatures during defrost cycles and require additional caution in terms of detector placement.

Protectowire can sometimes be routed around such “hot spots” within the spacing limitations. When this is impractical, a section of higher rated Detector can be spliced into the run. In uncertain situations, unwanted alarms will be avoided with little risk of delay in case of a real alarm, by using a Detector of the next higher rating throughout the area where the condition exists.

Detector Location & Spacing

Protectowire Linear Heat Detector may be installed at the ceiling level to protect areas within buildings (area protection) in the same fashion as the more familiar spot type heat detectors.

The majority of applications for linear detectors, however, involve installation of the detector close to the hazard in order to provide a rapid response. This is known as proximity or special application protection. Information on both types of installations will be provided.

Location

In general, Protectowire Linear Heat Detector should be located on the ceiling of the area to be protected, or on the sidewalls within 20 inches (500 mm) of the ceiling. It may also be located on the underside of solid joists or beams where the beams are less than 12 inches (300 mm) in depth and less than 8 feet (2.4 m) on center.

For special application protection, the Detector should be installed immediately above the particular hazard in such a way that it will be exposed to the hot gases emanating from any fire or mounted beneath a horizontal surface that will cause the same radial spread of heat as the ceiling of a room does in area protection applications.

In some applications, it is important to detect a slow heat rise or overheat condition before sufficient heat can be generated to cause an equipment failure or fire ignition. A typical

example would be in protection of electric motors or conveyor rollers which contain bearings that are subject to overheat and seizure. In this type of application, the advantage of Protectowire is that it may be installed in direct contact with the critical part, which ensures quick response.

Spacing

All Protectowire Linear Heat Detector models have been tested and assigned a listed spacing by Underwriters Laboratories (UL) and/or Factory Mutual Research Corporation (FM). Spacing is a horizontally measured dimension related to the maximum allowable detector coverage, and is determined by actual fire tests which are conducted in accordance with established approval agency test standards.

It is important to recognize that for open area protection, the listed spacing represents the maximum allowable distance between detector runs, and should be used as the starting point for detector layout design. Reduced spacing may be required based upon factors such as ceiling height and construction, physical obstructions, air movement, or the authority having jurisdiction. When Protectowire is used for sprinkler system activation, special Factory Mutual (FM) reduced spacing guidelines may

also be applicable. It is mandatory that engineering judgment be applied in determining final detector location and spacing.

Smooth Ceiling Spacing

On smooth ceilings, the distance between parallel detector runs shall not exceed the maximum listed spacing. There shall be a detector run within a distance of one-half the listed spacing measured at a right angle, from all walls, or partitions that extend to within the top 15% of the ceiling height, as shown in the illustration.

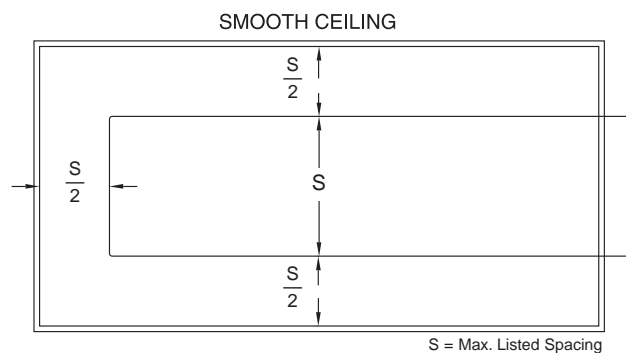

Figure 2

Solid Joist Construction

With open joists or other similar structures, heat

Temperature Ratings and Model Numbers (Use Linear Detector of Proper Temperature Rating)

Product Type	Model Number	Alarm Temperature	Max. Recommended Ambient Temperature	Approvals/Max. Listed Spacing	
				UL/cUL	FM
EPC					
Multi-Purpose/ Commercial & Industrial Applications	PHSC-155-EPC	155° F (68° C)	115° F (46° C)	50 ft. (15.2m)	30 ft. (9.1m)
	PHSC-190-EPC	190° F (88° C)	150° F (66° C)	50 ft. (15.2m)	30 ft. (9.1m)
	PHSC-220-EPC	220° F (105° C)	175° F (79° C)	N/A	25 ft. (7.6m)
	PHSC-280-EPC	280° F (138° C)	200° F (93° C)	50 ft. (15.2m)	25 ft. (7.6m)
	PHSC-356-EPC	356° F (180° C)	221° F (105° C)	50 ft. (15.2m)	See Note 1
EPR					
Good Weathering Properties & High Temperature Jacket Performance	PHSC-155-EPR	155° F (68° C)	115° F (46° C)	50 ft. (15.2m)	30 ft. (9.1m)
	PHSC-190-EPR	190° F (88° C)	150° F (66° C)	50 ft. (15.2m)	30 ft. (9.1m)
	PHSC-280-EPR	280° F (138° C)	200° F (93° C)	50 ft. (15.2m)	25 ft. (7.6m)
	PHSC-356-EPR	356° F (180° C)	250° F (121° C)	50 ft. (15.2m)	See Note 1
TRI					
Applications Requiring Pre-alarm	PHSC-6893-TRI	Pre-alarm: 155° F (68° C) Alarm: 200° F (93° C)	115° F (46° C)	N/A	15 ft. (4.6m)
XCR					
High Performance/ Industrial Applications Excellent Abrasion & Chemical Resistance	PHSC-155-XCR	155° F (68° C)	115° F (46° C)	50 ft. (15.2m)	30 ft. (9.1m)
	PHSC-190-XCR	190° F (88° C)	150° F (66° C)	50 ft. (15.2m)	30 ft. (9.1m)
	PHSC-220-XCR	220° F (105° C)	175° F (79° C)	N/A	25 ft. (7.6m)
	PHSC-280-XCR	280° F (138° C)	200° F (93° C)	50 ft. (15.2m)	25 ft. (7.6m)
	PHSC-356-XCR	356° F (180° C)	250° F (121° C)	50 ft. (15.2m)	See Note 1
XLT					
Multi-Purpose/ Excellent Low Temp. Properties	PHSC-135-XLT	135° F (57° C)	100° F (38° C)	50 ft. / 15.2m	30 ft. / 9.1m

Note 1: FM Approved for special application use only.
All Protectowire models can be supplied on Messenger Wire. Add suffix "-M" to above model numbers.

travels freely down the joist channels. However, heat has trouble spreading across the joists, so the distance in this direction must be reduced. The Protectowire shall be mounted on the bot-

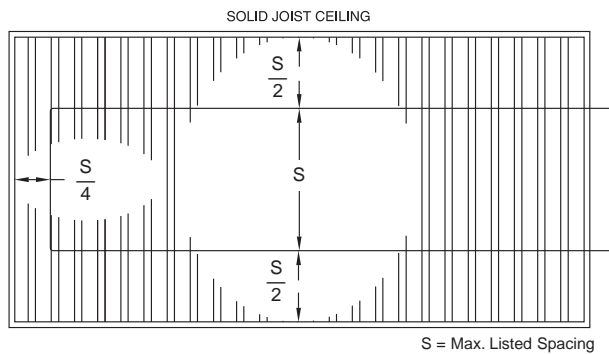

Figure 3

tom of the joists, and the spacing of the detector on all runs measured at right angles parallel to the joists shall not exceed 50% of the smooth ceiling spacing. On runs that parallel both joists and walls, the spacing shall not exceed 25%.

Beam Construction

In the case of beam construction where the beams are 4 inches (100mm) or less in depth, the ceiling shall be treated the same as a smooth ceiling. If the beams project more than 4 inches (100mm) below the ceiling, the spacing at right angles to the direction of beam travel shall not exceed two-thirds of the smooth ceiling spacing. Where the beams project more than 18 inches (46 cm) below the ceiling and are spaced more than 8 feet (2.4 m) on center, each bay formed by the beams shall be treated as a separate area requiring detector coverage.

Detector Mounting & Dead Air Space

Heat from a fire rises to the ceiling in a plume and spreads radially from the fire source. As the hot gases cool, they begin to bank down from the ceiling. The corner where the ceiling and wall meet forms an area known as “dead air space” as shown in Figure 4. In most fires, this dead air space is the triangular area formed along the ceiling by measuring 4 inches (10 cm) out from the corner, and 4 inches (10 cm) down the side wall. Protectowire should not be placed in this area.

High Ceiling Considerations

The purpose of this section is to discuss the effects of ceiling height on the installed spacing of Protectowire Linear Heat Detector and to explain the importance of modifying the listed

spacing in order to achieve detector response.

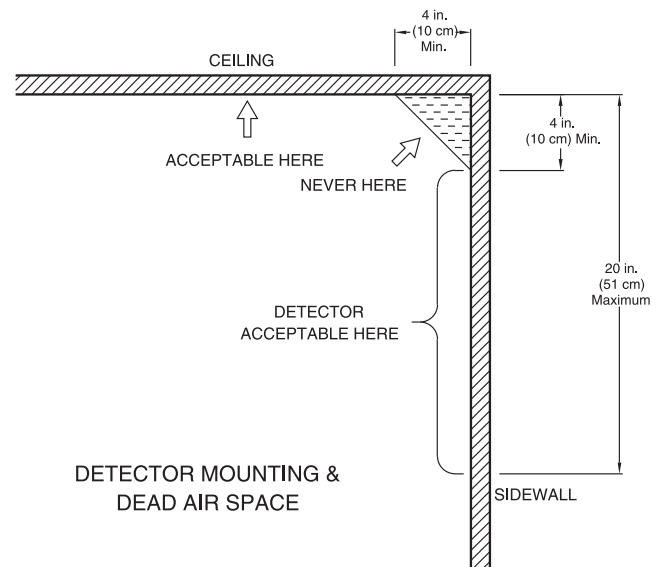

Figure 4

Logic tells us that a detector will ordinarily operate sooner in detecting a fire if it is closer to the fire source. This is because as smoke and heat rise from a fire, they do so in a plume which has the general shape of an inverted cone. The concentration of smoke and heat within the cone varies inversely as a variable function of the distance from the source. This characteristic is amplified during the early stages of a fire because the angle of the plume is wide. As the fire grows in size, the angle of the plume narrows, which tends to reduce the effect of ceiling height.

As the ceiling height increases, a larger-size fire is necessary to actuate the same detector in the same length of time. As a result of this, system design practice mandates that the listed spacing of heat detectors be reduced for the purposes of providing faster detector response to a fire, and to increase the likelihood that the detector will respond to a smaller fire.

To compensate for the effect that high ceiling installations have on detector performance, The National Fire Alarm and Signaling Code, NFPA 72, provides derating factors which can be applied to the listed spacing of any heat detector when installed on ceilings 10 to 30 feet (3m to 9.1m) high. These derating factors are shown as a percentage of the detector’s listed spacing, and have been developed to provide detector performance on higher ceilings [to 30 feet (9.1m)] that is equivalent to that of

detectors installed on a 10 foot (3m) ceiling. This method provides an accepted, easy to apply approach, in dealing with high ceiling applications for generalized fire conditions. It does not, however, provide guidance for ceiling heights over 30 feet (9.1m). In such installations, engineering judgment, the manufacturer's recommendation or detector spacing approved by the authority having jurisdiction should be used.

In many applications, Protectowire Linear Heat Detector is used for electrical activation of pre-action or deluge type sprinkler systems. In sprinkler release applications, special Factory Mutual (FM) spacing requirements may be required. In some cases, FM spacing requirements may conflict with the recommendations for high ceilings provided in NFPA 72. In these situations, general practice is to utilize NFPA 72 recommendations in systems involving detection only, and to follow FM detector spacing guidelines when designing a detection system to be used for sprinkler system release. In all cases, the final detector spacing must be accepted and approved by the authority having jurisdiction.

The reduction of heat detector spacing on high ceilings as required in NFPA 72, is by no means universally applied. Several types of heat detectors including "line-type electrical conductivity detectors," more commonly known as analog line-type detectors, have been identified in NFPA 72 as an "exception" to the high ceiling derating requirements. This "exception" has been promoted on several levels to infer that analog detectors have been excluded from the reduced spacing requirements due to superior performance.

In actual fact, The Fire Detection Institute Fire Test Report, which was used as a basis for the high ceiling derating information contained in NFPA 72, does not include data on integration-type detectors and therefore, "exception" was granted only until such time as data is developed for this type of detector.

For the purposes of this manual, good system design dictates that the listed spacing of all installed heat detectors, regardless of operating principle, be reduced to compensate for the effects of ceiling height.

PROTECTOWIRE SPACING FOR SLOPED CEILINGS

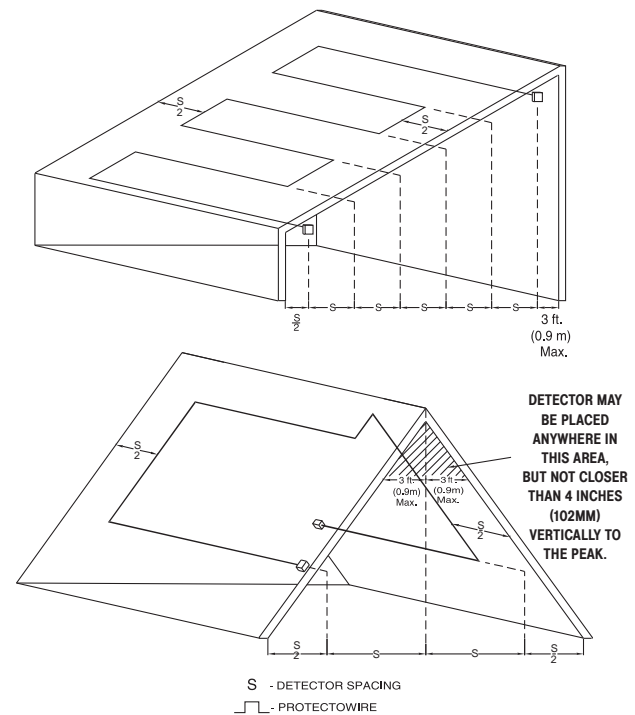

Figure 5

Sloped Ceilings

In areas having a sloped or peaked ceiling, at least one line of Protectowire must be located at or within 3 feet (0.9 m) measured horizontally from the peak, but not closer than 4 inches (10 cm) vertically to the peak. The spacing of additional runs of Protectowire, if any, should be based on the horizontal distance projected down from the ceiling and in accordance with the type of ceiling construction.

Pre-Action Sprinkler Systems

When Protectowire Linear Heat Detector is used as the initiating device for pre-action sprinkler systems, special Factory Mutual location and spacing guidelines may be found in FM Loss Prevention Data Sheets such as 8-29, which covers Refrigerated Storage Facilities.

As a general rule, FM acceptance criteria for open area ceiling applications such as that covered in 8-29, requires that the detector be installed at a spacing not exceeding the allowable ceiling sprinkler spacing. The detector spacing is accomplished by maintaining a continuous run of Protectowire parallel to each branch line. At the end of each branch line the detector is run at a right angle (maintaining the appropriate 2.5 inch [6.4 cm] bend radius) across to the next

adjacent branch line and proceeds in the opposite direction. The detector run continues in this manner until the end of the detection zone is reached, or until the maximum Protectowire control panel zone allocation is reached, typically 5,000 feet [1,524 m].

The completed Protectowire portion of the circuit for each overhead zone will be in a serpentine pattern as illustrated in Figure 6, with the Protectowire terminated at each end in an approved zone box, end-of-line zone box, or

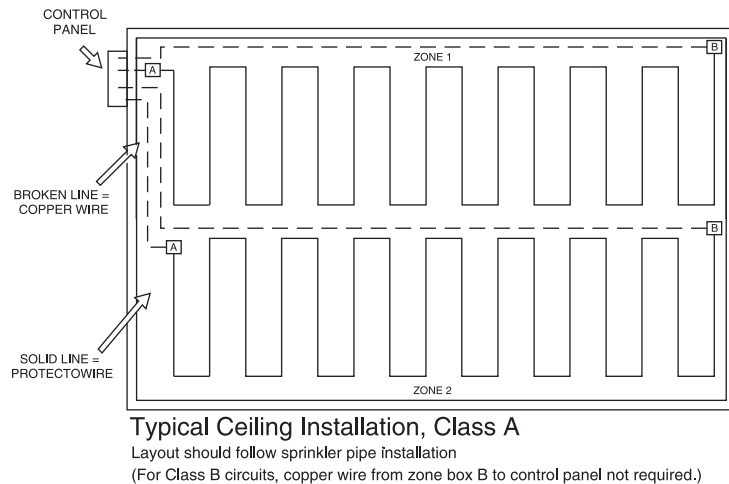

Figure 6

other approved junction box provided as part of the system. Strain relief connectors, Series SR-502, shall be installed in all junction boxes where Protectowire enters or exits the enclosure, in order to hold the cable securely and maintain dust and moisture tight conditions. (See Figures 1, 1A, 1B).

Detector Zoning For Sprinkler Release

Detection system zone allocation should not be confused with zone allocation for sprinkler systems. A water system, or sprinkler zone controlled by one valve may have a different meaning than terminology used for detection zones. Generally, a detection zone refers to a defined area within a protected premise. In the case of Protectowire, it also refers to the maximum amount of linear heat detection cable that a panel will operate on a single detection circuit (zone). Protectowire panels such as the FS2000, SRP-4x4, and 2600 HD Series are approved for 5,000 feet (1,524 m) per zone.

On the other hand, a water zone, or system, has an area of coverage based upon its designed discharge density which may exceed the area which can be covered effectively by a single detection zone. When a detection zone's length limitation is exceeded, a second detection zone is required to complete the total area of detector coverage needed to match the area of coverage provided by the corresponding water zone. In this scenario, the two detection zones are connected at the control panel in an "or" configuration so that the actuation of either detection zone will operate the solenoid of the corresponding water system. Do not extend a detection circuit from one area into an area serviced by another water valve. Each water valve must be controlled by one or more detection zones physically located in the same area.

Rack systems - With the variety of rack systems in use today, a wide range of configurations may be confronted when installing linear heat detection systems for electrical actuation of sprinkler valves. As a minimum, the guidelines of Factory Mutual in conjunction with the manufacturer's recommendation must be followed. In general, rack detection systems should be installed based upon the following criteria:

For single row and double row racks, one line of detection cable is needed at each in-rack sprinkler level. Locate the linear heat detector cable in the transverse or longitudinal flue space and attach it to a horizontal load beam at the sprinkler line level.

For multiple-row racks, a line of detection cable is needed for each in-rack sprinkler line at each in-rack sprinkler level. Locate the linear heat detection cable in either the transverse or longitudinal flue space and attach it to a horizontal load beam at the sprinkler branch line levels.

Environmental Considerations

Protectowire is available in a range of constructions and jacket materials, in order to provide resistance to attack from various

chemicals, liquids, and environmental factors.

To assist the System Designer in selecting the proper Protectowire model for the installation environment, a Chemical Resistance Chart for the jacket materials used in all Protectowire Linear Heat Detector models is shown on page 26 of this manual. This chart lists the effects of many common chemicals, and is useful in determining the suitability of installing Protectowire in various types of aggressive environments.

Because it is not always possible to accurately predict what effect extremely aggressive environmental factors may have on a Detector's useful service life, we recommend that when possible, actual field installation tests be performed on product samples to determine whether or not the model selected may be suitable for use in the proposed environment.

In outdoor applications, the effects of solar radiation must also be considered during the design of the system. Exposure to direct sunlight or so called "black body" radiation may cause the temperature of the detector or its mounting surface to exceed the maximum ambient limit or the alarm actuation temperature of the sensor.

It is important, therefore, to take precautionary steps, such as installing a protective shield over the sensing cable to reduce the installed location temperature to acceptable limits. Shielding also reduces the long term degradation of the outer jacket from influences such as ultraviolet radiation. Protectowire models XCR and EPR have special inhibitors in the jacket material to help reduce the effects of UV radiation and extend the detector's useful service life.

For outdoor applications, the recommended method of splicing and terminating the Protectowire, requires that all connections be made within appropriately rated junction boxes. All other applications, particularly where high humidity or dampness may be present, require the use of SFTS Sealant Tape for all in-line splices using PWSC or PWS splicing devices. Refer to Figures 7A and 7B for the correct PWS and PWSC splicing procedures.

Directions For Use of PWS Splicing Sleeves

1. Remove insulation from each wire to half the length of sleeve, preserving conductor insulation 3/8" (.9cm) from bare wire back to braid:

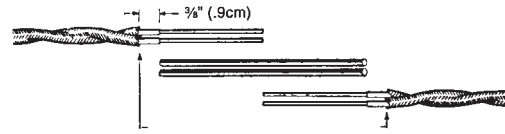

2. Put sleeve on one pair of wires and with chain nose pliers make an "S" bend in sleeves and wires to secure them to each other:

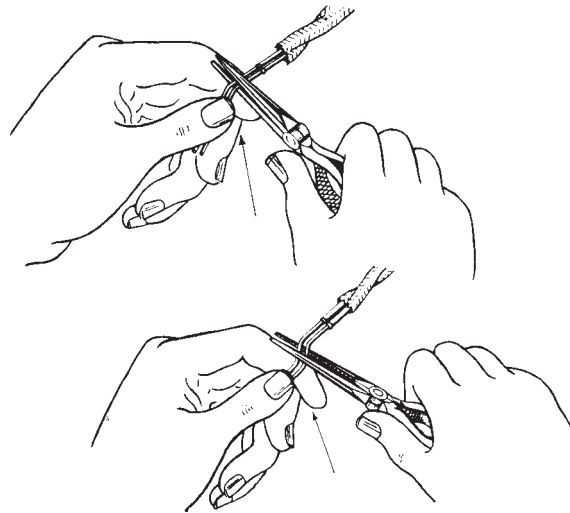

3. Insert other pair of wires in sleeves and make a similar "S" bend. The result should look like this:



4. Double a strip of "Scotch" electrical tape No. 33+ or No. 35 (the adhesive on the other tape may in time soften the heat-sensitive insulation and cause false alarms) to make a non-adhesive insulating pad.
5. Cut this pad just long enough to reach from jacket to jacket of the two cable ends and insert it between conductors:



6. Roll insulating pad around the conductors and tape over all to hold insulating pad in place and exclude moisture. The use of SFTS sealant tape is recommended prior to applying the final electrical tape wrap.

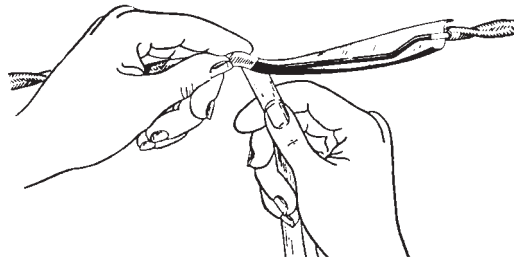

7. Finished splice.



Figure 7A

Directions For Use of PWSC Splicing Connectors

1. Remove insulation from each wire leaving 1/2" (1.3cm) of bare Protectowire Linear Heat Detector conductor, preserving 3/8" (.9cm) of insulation from bare wire back to the covering.

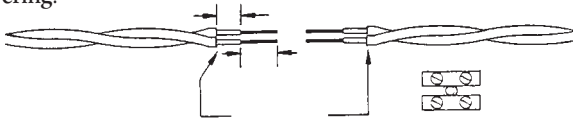

2. Install wires as shown below making sure the entire 1/2" (1.3cm) portion of bare Protectowire Linear Heat Detector conductor is embedded in splicing connector.

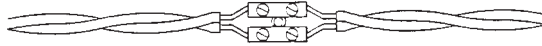

3. Secure Protectowire Linear Heat Detector by tightening the connector screws. Plastic screw turrets may be trimmed with snips or utility knife for easier taping.



4. Using 4"-5" (10.1cm-12.7cm) of SFTS tape, starts at least 2" (5.1cm) before connector and wrap the splice. Stretch and overlap each wrap of tape by 1/4-1/2 the width. SFTS tape is recommended specifically for outdoor or high humidity installations.

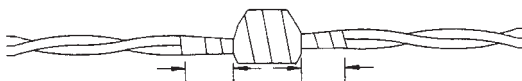

5. Finish the splice seal by wrapping "Scotch/3M" brand "Super 33+" or "No. 35" electrical tape over the SFTS sealant.

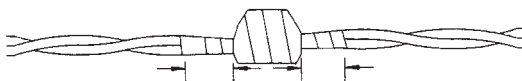

Flexible Leads

Flexible leads are furnished with most Protectowire systems for connecting Protectowire Linear Heat Detector to terminals.



Attach these to the Detector ends, insulate and tape like a splice:



Figure 7B

Installation Detail

Installation efficiency will be gained by carefully planning the routing of each Protectowire run. This will ordinarily be done on the basis of a scale drawing of the area to be protected, consideration of the location and spacing information presented in the Detector Location and Spacing Section of this manual, and other less obvious factors which may be observed at the site.

Protectowire is designed to respond rapidly to changes in temperature caused by a fire. Therefore, its mounting hardware must provide adequate support at temperatures which are at least as high as the alarm trip point.

Fasteners should typically be spaced every 5-10 feet (1.5-3m), or as may be necessary to prevent the wire from excessive sagging which puts undue stress on the wire at the fastening points. Improper installation and fastening may also subject the Detector to physical damage in some process areas or interactive applications, such as rack storage facilities.

Fasteners

Protectowire approved fasteners are generally designed to lightly clamp the detector which enables a tension to be applied progressively. This method is better than arrangements which apply a high tensile load at the end of each run or clamp and compress the sensor cable so tightly that the inner insulation becomes damaged. *To ensure a trouble-free installation, only Protectowire supplied or approved fasteners should be used. The use of non-approved fasteners may physically damage the Detector thereby causing "false alarms" and in some cases void the Detector's warranty.*

Several categories of approved fastening devices are available to hold the detector in place without injuring it. These include:

- **General Purpose** - These fastening devices are commonly used in area detection applications where the Detector will be installed on the ceiling, roof or side walls.
- **Cable Tray Applications** - These versatile fasteners are intended to mount the Detector to a variety of cable tray configurations, but may also be used for many other mounting situations such as conveyors, angle irons, I-beams, bar joists, etc.
- **Pipe Mounting** - A category of fasteners which allow the Detector to be mounted directly to associated sprinkler pipes in various pre-action and deluge systems.
- **Messenger Wire** - When installing Protectowire with optional stainless steel messenger (support) wire, eyebolts and turnbuckles are required. Ideal for spanning large open areas or where mounting support structures are limited.

General Purpose Fasteners

WAW Clips - One of the most versatile fasteners is the WAW. They may be used for ceiling or wall mount applications, as well as at all corners (turns) except in messenger wire, drive ring or pipe mounted installations. The fastener is a clip

which wraps around the Detector and is available in either nylon (WAW-N) or polypropylene (WAW-P) material depending upon the installation environment. The WAW takes a No. 6, 8, or 10 screw, which may be a wood screw, toggle bolt, drive screw, etc. as required to hold securely to the mounting surface.

As a general rule, the nylon fasteners are preferred for applications where the ambient temperatures are expected to be low such as in freezer warehouses, and the polypropylene model is for use in higher temperature installations.

The WAW Series fasteners (WAW-N & WAW-P) are not recommended for use in installations where the minimum continuous temperature is less than -40°F (-40°C) or the maximum continuous use temperature will exceed 190°F (88°C).

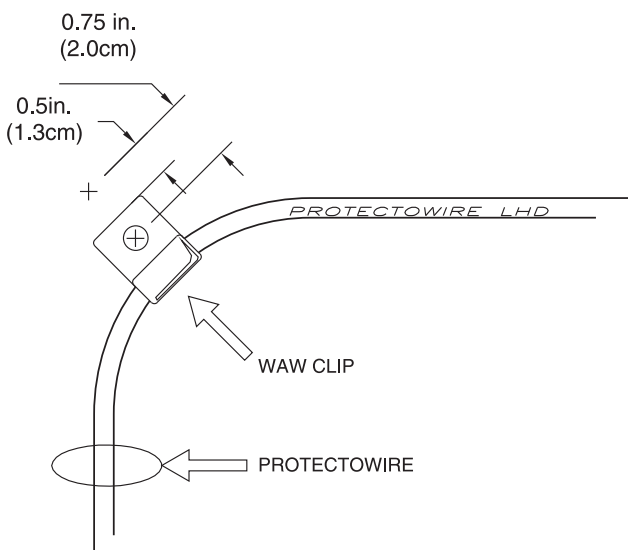

Figure 8

When installed at the corners (turns) of ceiling mounted installations, the WAW mounting screw should be set in 1/2 to 3/4 inch (1.3-2.0cm) from the intersection of the lines (Figure 8) to provide a free bend in the Detector, and should not be fully tightened until fastening between corners has been completed. Installation is simplified and the best appearance assured by pulling the Detector into line from corner to corner and applying the required intermediate fasteners while a light tension is held upon it.

OHS Line Clips

The OHS clip is available in several different configurations and is used mainly as an intermediate fastener between corner mounted WAW clips, which provide the main support.

The OHS-1 galvanized clip and the OHS-SS stainless steel clips are designed to be used either indoors or out, and are compatible with all Protectowire models with extruded outer jackets.

The OHS-1 clip contains a 3/16 inch (4.8 mm) diameter mounting hole while the stainless steel model, OHS-SS is provided with a 1/4 inch (6.4 mm) diameter mounting hole. These clips may be held in place by any suitable mechanical fastener such as a wood screw, nut and bolt, sheet metal screw, or threaded stud of suitable length for the application.

Beam Clamps

The BC Series Beam Clamp Assembly, consists of a beam clamp, WAW clip and snap button. The models currently available are the BC-2 which utilizes a plated steel clamp and is rec-

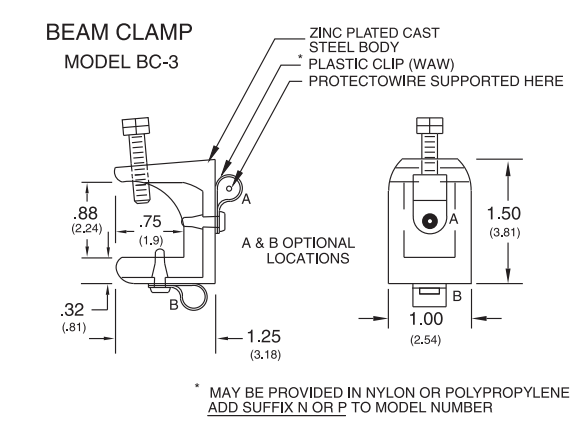
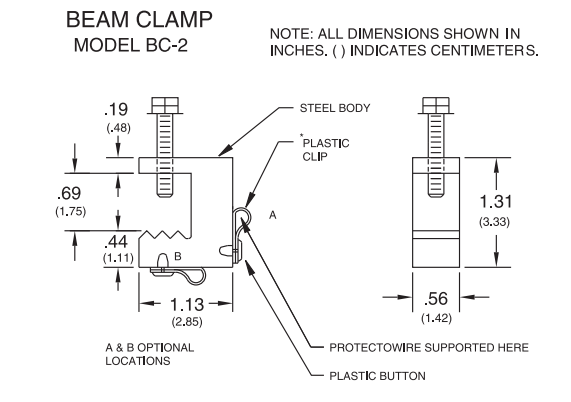

* MAY BE PROVIDED IN NYLON OR POLYPROPYLENE
ADD SUFFIX N OR P TO MODEL NUMBER

Figure 9

ommended for general indoor use and the BC-3 which utilizes a heavy duty zinc plated clamp suitable for both indoor and outdoor use. These versatile fasteners may be used for mounting Protectowire on cable trays, conveyors, angle irons, I-beams, bar joists, etc.

PDR Miniature Drive Rings

This fastener is a PROTECTOWIRE development, and consists of a nail and hook assembly. It is easy to apply, with or without the special driver. The Detector is hooked into the hook eye after the nail is driven and slides readily through it. On any uneven surface such as rough plaster board, the slight separation from the surface tends to straighten the detector line and improve the finished appearance.

Both the nail and the hook eye are hardened steel, alloy plated. Nails are 1 1/4 inches (3.2cm) long for use on a variety of supports. With a little care and patience the nails can be driven into mortar joints with light taps, to provide an easily applied fastening to masonry.

Adhesive Cable Mounts

In some installations, the use of mechanical fasteners that require drilling into the mounting surface is prohibited, or simply not possible. An example of this type of application is the mounting of Protectowire directly onto large power transformers. For many of these situations, the only viable solution is to utilize an adhesive mounting system consisting of EMS Cable Mounts, PLT Cable Ties and an approved industrial adhesive. The EMS Cable Mounts and PLT Cable Ties are constructed of black weather resistant nylon, and when used with the approved adhesive, are suitable for outdoor use.

As a cautionary note, the use of adhesive mounting should be limited to applications which will not be subjected to temperature extremes or harsh chemical environments that could effect the service life of the adhesive and cause it to fail prematurely. Installation environments which contain solvents, strong acids or alkalis should always be avoided. In addition, the adhesive mounting system shall not be used where the continuous operating temperature will be less than 0°F (-18°C) or exceed 180°F (82°C).

RMC L-Bracket

The RMC Series L-brackets consist of a steel bracket, WAW Clip and snap button and are often used for mounting Protectowire to the rim seals on floating roof tanks. The brackets are 6.7 inches (17.0 cm) long and contain five mounting holes which allow for multiple height adjustments of the Detector's installation position. The brackets are available in plated steel or stainless steel models, and may be used in a wide variety of common installations and applications.

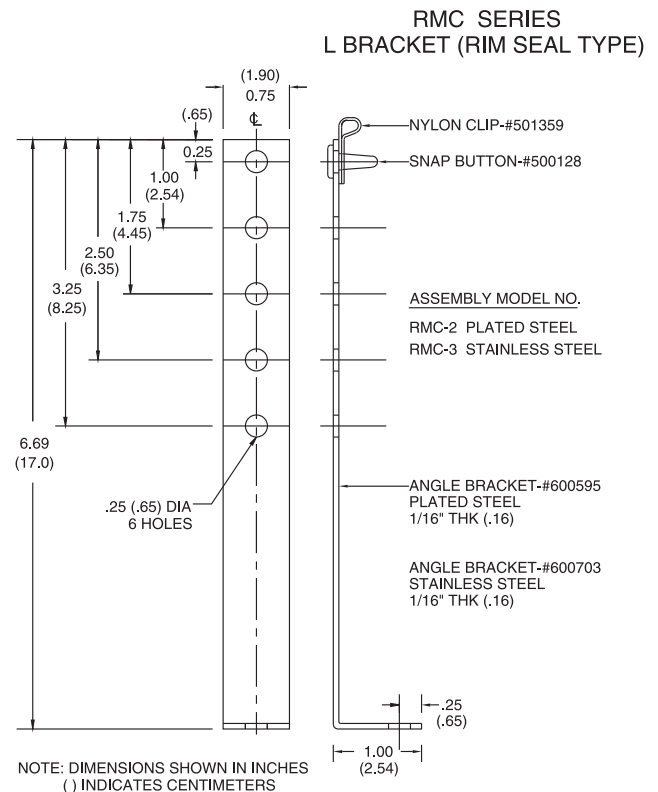

Figure 10

Staples

Staples installed with staple guns or drivers are generally not recommended for fastening Protectowire Linear Heat Detector. Most commercially available staple guns which use flat staples will crush or pinch the Detector causing shorts and unwanted alarms. Experience has also shown that even in the most skillful hands, some quantity of staples will be improperly placed during installation thereby penetrating the outer jacket and injuring the Detector internally.

In rare situations where the use of staples is considered to be the only appropriate means

of fastening, an Arrow Model T-25M Staple Gun or equivalent must be used. This type of driver utilizes a crown head staple and is designed to minimize the risk that the staple will be driven into the Detector hard enough to crush or pinch it. The risk of damaging the wire may be further reduced by selecting a staple of proper length based upon the hardness of the mounting material.

Cable Tray Applications

CC-2 Clips

These cable tray clips consist of a “Caddy” style steel clamp, WAW, and snap button. They are designed to attach to the cable tray side rails and secure the Protectowire in the recommended sine wave pattern.

The clips are available in two models, each designed to accommodate different material thickness. Model CC-2N will clamp to material from .06 to .16 of an inch (1.6 - 4.0 mm) thick. Model CC-2W is designed for material ranging from .16 to .25 of an inch (4.0 - 6.4 mm) thick.

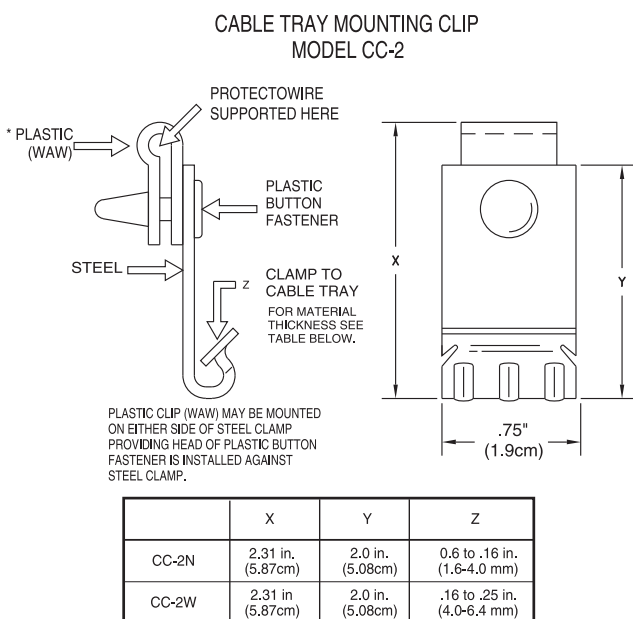

Figure 11

CC-10 Clips

The CC-10 Series Clips, are similar in concept to the CC-2's, but utilize a different “Caddy” style drive clamp. The CC-10's will accommodate material thickness of up to .50 inch (12.7 mm) and also provide a means of locking the fastener in place by using one of the threaded mounting holes.

The CC-10N is designed for material ranging from .13 to .25 of an inch (3.2 - 6.4 mm) thick. The CC-10W will clamp to material from .31 to .50 of an inch (7.9 - 12.7 mm) thick. By adding the suffix “-S” to the above model numbers, the fasteners are provided with a 1/4-20 hex nut and 3/4 x1/4-20 hex screw which are designed to securely hold the clamp to the mounting surface. These clamps are particularly useful in applications where excessive vibration may be encountered.

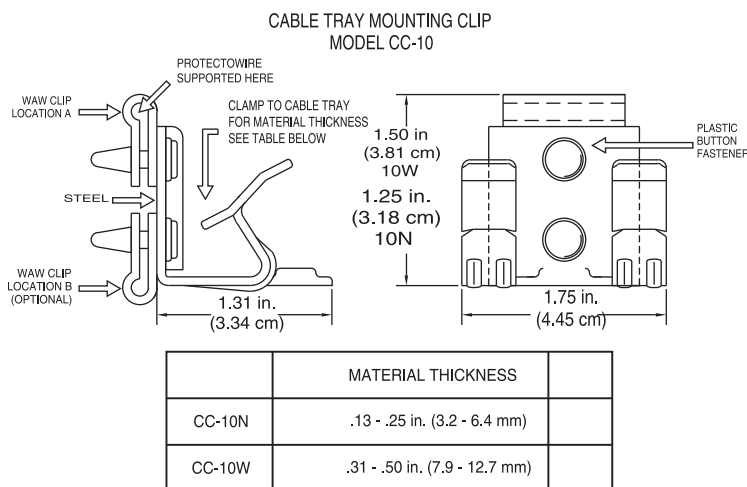
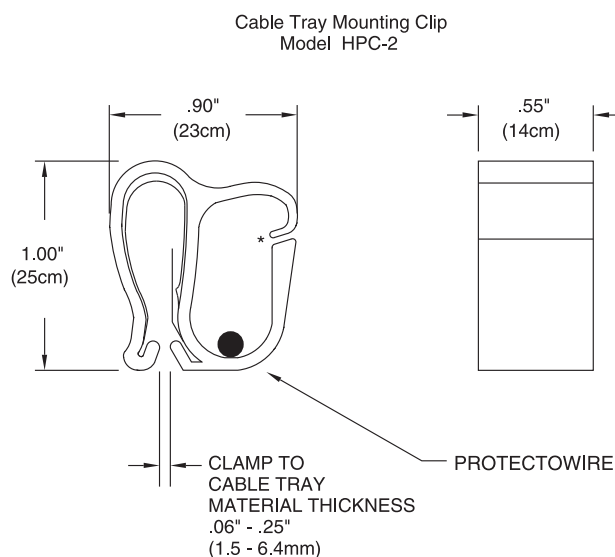

Figure 12

HPC-2 Clips

This single piece UV resistant nylon clip consists of a special snap-lock design, which allows for easy installation or removal of the Protectowire Linear Heat Detector from the fastener.



* NOTE: Clip Shown Unlatched

Figure 13

The HPC-2 contains an internal spring steel drive clamp with gripping teeth that will accommodate mounting surfaces from .06 to .25 inches (1.5 - 6.4 mm) thick, making the clip suitable for a wide range of applications such as cable trays, storage racks, and ceiling joists.

Pipe Mounting

PM-3 Series Straps

The extensive use of Protectowire systems to activate pre-action and deluge type sprinkler systems, has led to the development of the PM-3 Series Pipe Mounting Straps. These double loop straps are made of black weather resistant 6/6 Nylon and may be used in temperatures ranging from -40°F (-40°C) to 185°F (85°C). To maintain flexibility and minimize breakage during installation, PM-3 Series Pipe Straps should be installed at ambient temperatures above 32°F (0°C) whenever possible.

In low temperature applications such as refrigerated warehouses and freezers, where it may be necessary to commence installation while the facility is at subfreezing operating temperature, the PM-3's should be kept at normal room temperature prior to installation. The quantity of PM-3's taken into the subfreezing installation area at any one time should be limited to the number of straps which can reasonably be installed during a 15 to 20 minute interval.

Regardless of the technique used for this type of installation environment, some degree of strap breakage must be anticipated. This is due to the extreme cold which reduces the PM-3's flexibility and consequently, the amount of bending and stress which the fastener will withstand.

Despite the similarity of the PM-3's to standard ty-raps, the use of commercially available single loop ty-raps is not recommended for installing Protectowire Linear Heat Detector. Standard ty-raps are easily overtightened during installation which prevents the wire from expanding and contracting during temperature changes. This type of stress will eventually cause insulation damage to the Detector resulting in unwanted alarms.

Messenger Wire

Messenger wire (a Protectowire innovation), is available with any model Detector on spe-

cial order. It consists of high tensile strength stainless steel wire, which is wound around the Detector at the rate of approximately one turn per foot (.3 m). It is a carrier or support wire which is designed to simplify the installation of the Detector in areas where mounting is difficult due to the lack of appropriate support structures or mounting surfaces.

When using messenger wire to support the Detector, turnbuckles and eyebolts must be employed at each end of a straight run to place tension on the support wire. The maximum Detector run length between turnbuckles should not exceed 250 feet (76 m) and the wire must also be supported with approved intermediate fasteners at intervals typically ranging from 15 (4.5 m) to 20 feet (6.0 m). The final spacing of intermediate fasteners is largely determined by each individual application, however, spacing should never exceed 50 feet (15 m) as excessive sag will result. Outdoor messenger wire installations present additional challenges due to environmental factors such as snow loads, ice build-up or wind. Increased detector support must be provided by using additional intermediate fasteners with closer spacing in all outdoor installations.

MESSANGER DETAIL
RECOMMENDED FOR USE ON HIGH CEILINGS IN LARGE OPEN AREAS

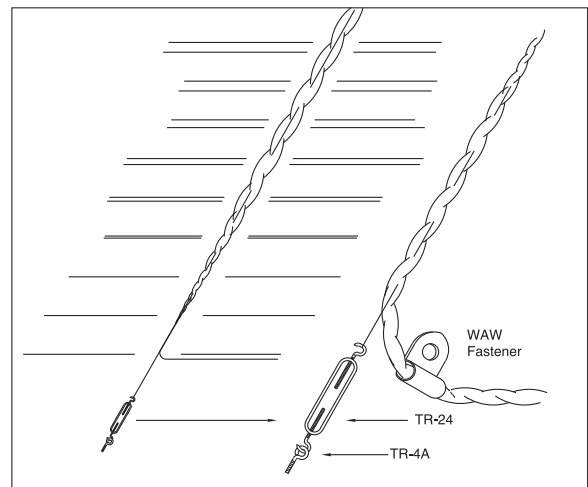

CLIMBING IS SIMPLIFIED BY SECURING
TURNBUCKLES TO END WALLS OR STRUCTURAL MEMBERS.
ON LONG RUNS SUPPORT WITH APPROVED FASTENINGS
EVERY 15 TO 20 FEET (4.5 - 6.0m) TO REMOVE SAG.

Figure 14

The summary list of those fasteners contained in this section of the manual, are suitable for use in a wide range of applications and are all

available from The Protectowire Company. While it is not possible to stock a standard fastener for every conceivable installation, alternative fasteners may be available on special order. Please contact the factory for assistance with your specific installation requirements.

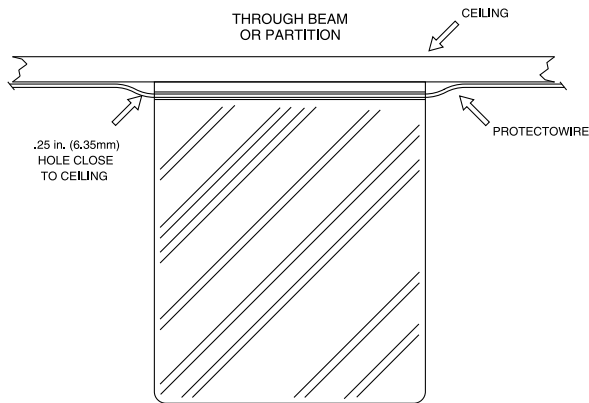

Figure 15

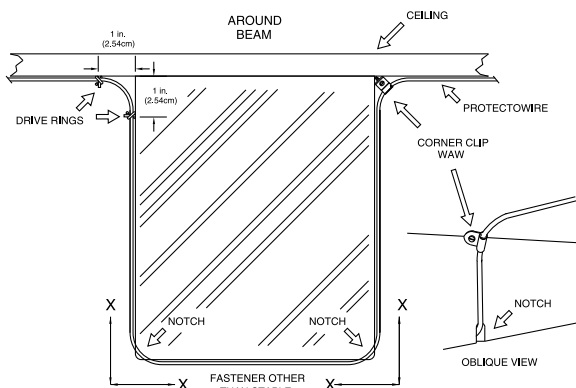

Figure 16

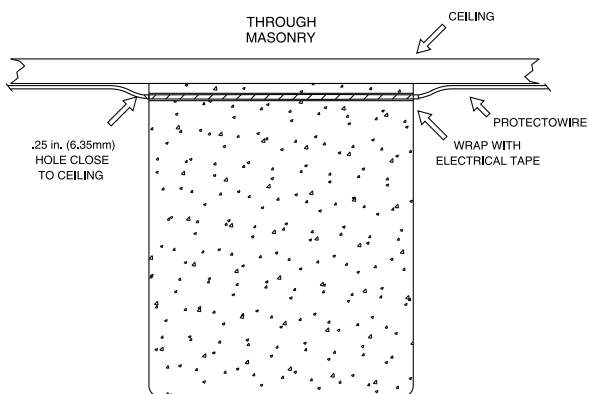

Figure 17

Drilling Holes

Care in drilling holes through partitions and beams is the first element of good installation.

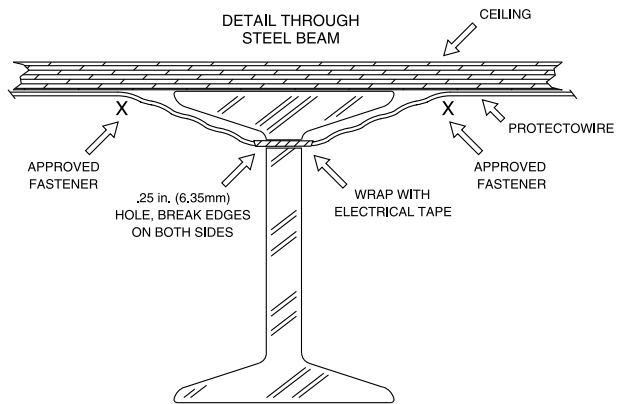

Figure 18

Properly located holes work for the installer by helping to hold the Detector in place. Improperly located holes work against him by requiring additional fastenings and increased risk of mechanical damage to the Detector.

Installation Warnings

Protectowire is not fragile, but crushing or pinching will injure it. The results of such injury may not appear at once and may not be obvious by the outward appearance of the wire, but damage to the outer jacket or unnecessary mechanical stress applied to the wire during installation may cause "false alarms" later on. Therefore:

- DO NOT leave it on the floor and walk on it or set ladders on it during installation.
- DO NOT install it with commercial fasteners unless specially approved by The Protectowire Company.
- DO NOT place it where it will be subject to mechanical damage by equipment processes.
- DO NOT overtighten the fasteners as this may breach the outer jacket or crush the inner insulation, causing unwanted alarms. All fasteners must allow the wire to expand and contract with temperature changes.
- DO NOT over stretch the Protectowire runs, some wire "sag" between fasteners is normal.
- DO NOT MAKE 90° BENDS IN THE DETECTOR.
- DO NOT hold the wire with pliers to make bends. All bends should be made with the fingers and consist of rounded turns with a minimum 2.5 inch (6.4 cm) radius.
- DO NOT use wire nuts or other similar devices. All connections must be made via terminals and/or Protectowire approved splicing devices.
- DO NOT PAINT THIS DETECTOR, per UL and FM requirements.

Mechanical Protection

Whenever the Detector comes within 6 feet (1.8m) of the floor, it should be enclosed in conduit. This applies particularly to entry into manual stations, control units, zone or end-of-line junction boxes, and to all runs through floors.

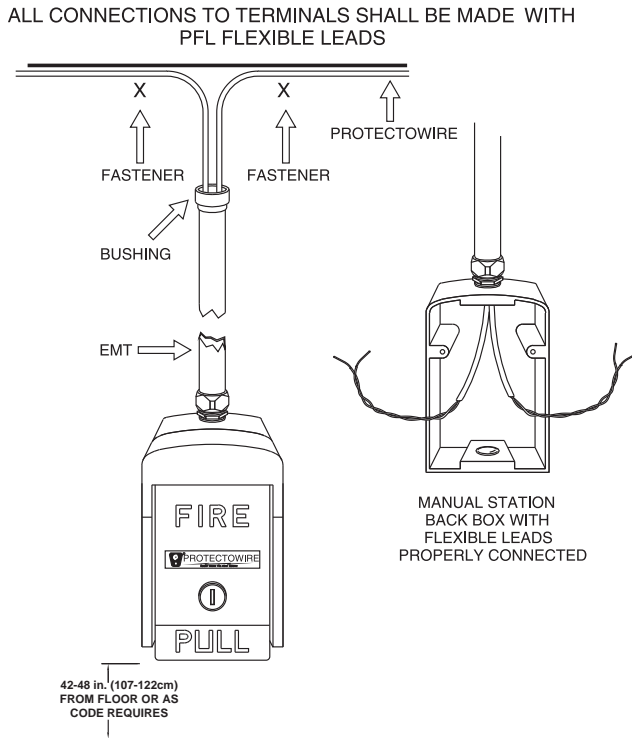
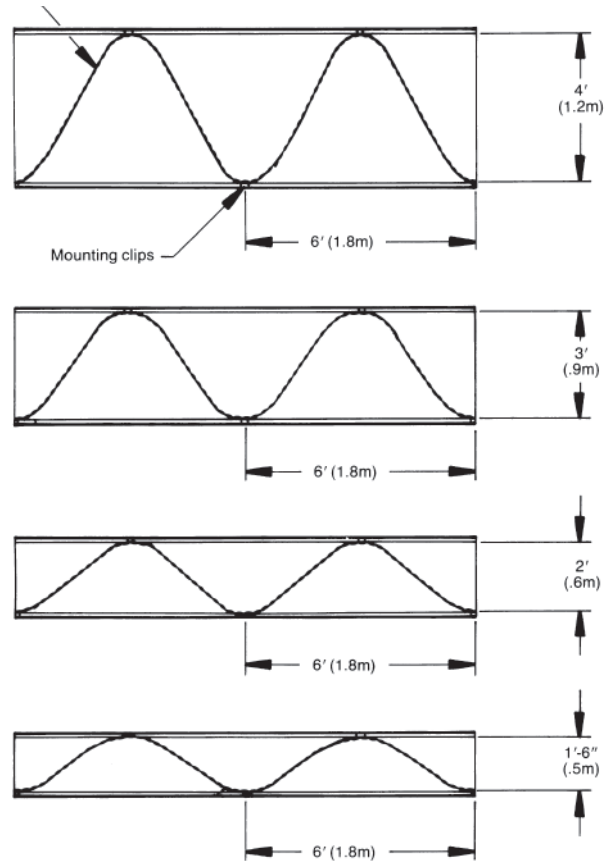

Figure 19 Detail at Manual Station



Estimating chart and formulas	
Width of cable tray	Multiplier
4 ft. (1.2m)	1.75
3 ft. (.9m)	1.50
2 ft. (.6m)	1.25
1 ft. 6 in. (.5m)	1.15

Length of cable tray x multiplier = Length of Protectowire
 Length of cable tray in feet ÷ 3 + 1 = Number of mounting clips
 (Approx. 1.1 clips per meter of cable tray length + 1)

Figure 20

Special Application Installations

“Where a line-type detector is used in an application other than open area protection, the manufacturer’s installation instructions shall be followed,” (NFPA 72-10). This section of the manual is intended to provide general guidance for installing Protectowire in several special applications such as cable trays, conveyors, etc. Protectowire Linear Heat Detector should typically be installed as shown in the following diagrams with reference to the corresponding application.

Cable Trays

Figure 20 illustrates Protectowire Linear Heat Detector installed in a sine wave pattern in a cable tray. The Detector is run on top of all power and control cables in a tray and is

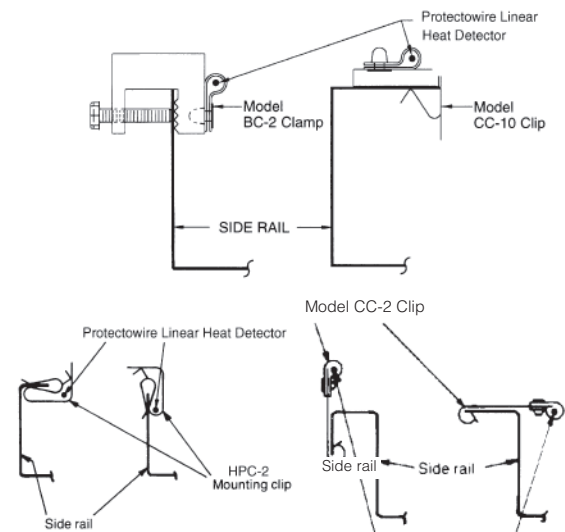

Typical Cable Tray Mountings

Figure 20A

spaced as shown in Figure 20. When additional cables are pulled into the tray they should also be placed below the Detector.

Figure 20A illustrates the application of BC-2, CC-2, CC-10, and HPC-2 mounting clips to various types of cable trays.

Conveyors

Belt type (overhead installation) Figure 21 illustrates Protectowire Linear Heat Detector with Type M messenger wire installed directly over the conveyor to be protected. Whenever possible, the Detector should be fastened to a covering which is not more than 7.5 feet (2.3m) above the conveyor belt and which is in a horizontal plane or parallel to the line of the conveyor. This will act as a heat collector and will provide earlier detection. Support is provided by messenger wire* which is fastened with a turnbuckle at a maximum distance of 250 feet (75.7m). Approved intermediate fastening devices are used at intervals of 15 feet (4.5m) to 20 feet (6.0m) to ensure detector tautness.

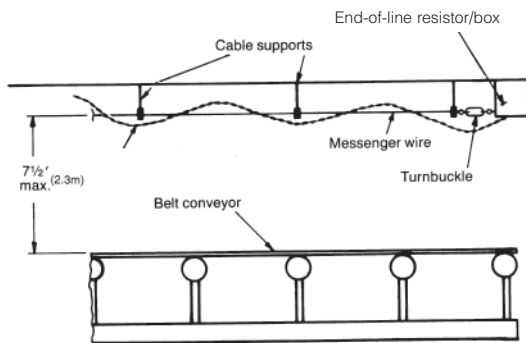

Belt type (idler arm installation)
Figure 21

Figures 21A and 21B illustrates Protectowire Linear Heat Detector with Type M messenger wire installed on either side of the belt in the area between the idler and the roller. Support is provided by messenger wire* which is fastened with a turnbuckle at a maximum distance of 250 feet (75.7m) to ensure Detector tautness. Approved fastening devices are used at each idler to avoid detector contact with moving parts.

Belt side installation - See Figures 21C and 21D. (a) A third optional location for installa-

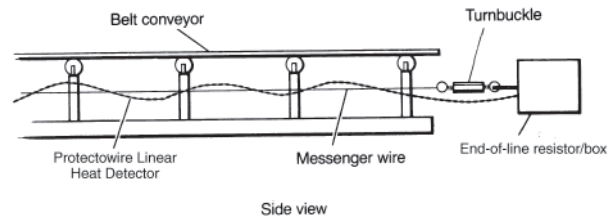

Side view
Figure 21A

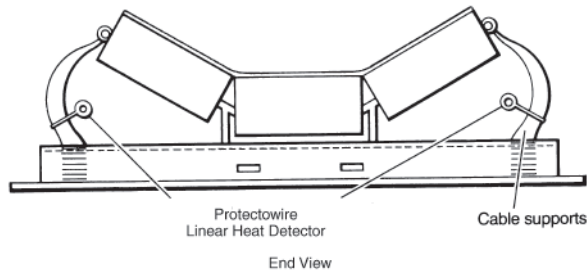

End View
Figure 21B

tion of Protectowire Linear Heat Detector is beside and slightly above the belt.

(b) Install the Detector with Type M messenger wire* on both sides of the belt beneath a 3 x 3 x 1/8 inch (7.6cm x 7.6cm x .3cm) angle iron which is used as a heat collector and a support. The angle iron should be located 3 to 4 inches (7.6cm to 10.2cm) above the belt and directly over the line of the outboard roller bearings.

(c) Support the Detector by securing the messenger wire to turnbuckles and eyes located at intervals of up to 250 feet (75.7m) and also by the use of Protectowire approved fasteners

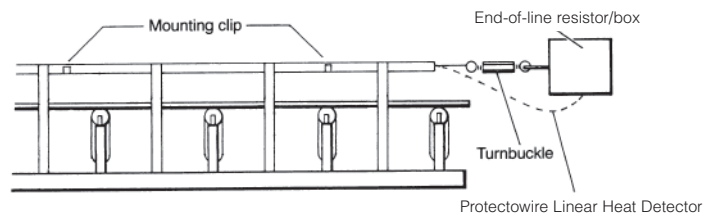
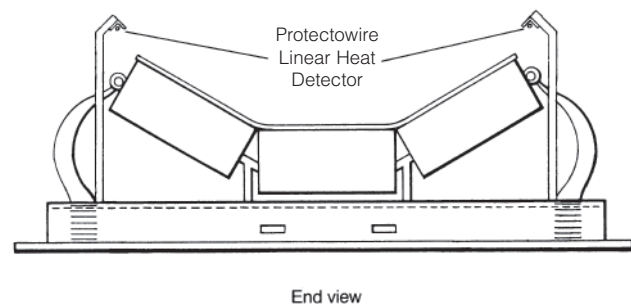

Figure 21C



End view
Figure 21D

spaced about 15 feet (4.5m) to 20 feet (6.0m) apart to limit drooping and avoid contact with moving parts.

(d) An alternate method is to use the Detector without messenger wire and fasten the Detector directly to the angle iron at intervals of 5 feet (1.5m) to 10 feet (3.0m) with approved mounting clips.

*The use of messenger wire is optional; however, when not employed additional fasteners may be required.

Power Distribution Apparatus

Figure 22 illustrates Protectowire Linear Heat Detector laced through a motor control panel. It is secured with PM-3 wire straps to the apparatus being protected. Other equipment that may be protected in the same manner includes transformers, switchgear, substations, resistor banks, etc. where ambient temperatures do not exceed the Detector's rating.

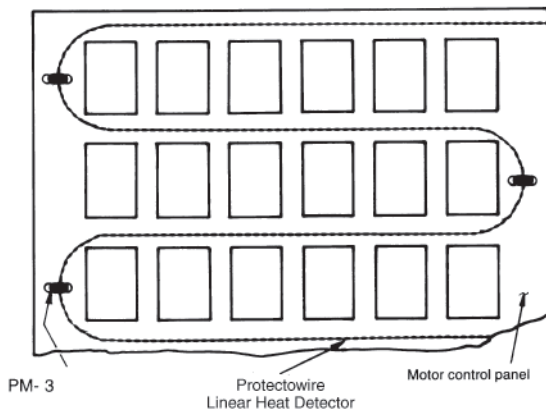
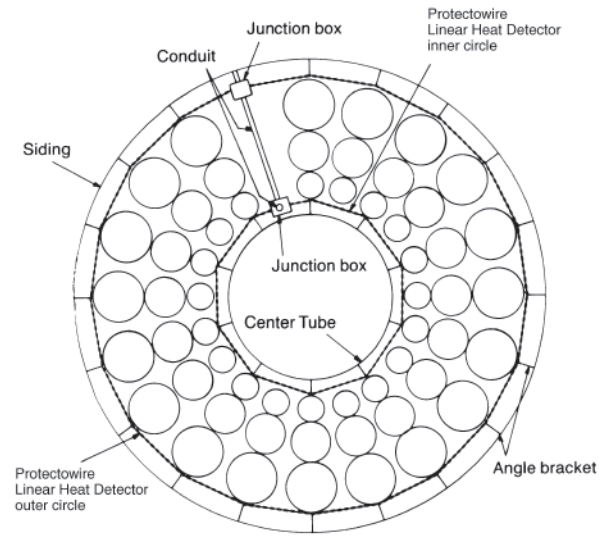

Figure 22

Dust Collectors/Baghouses

Figure 23 illustrates Protectowire Linear Heat Detector, supported by angle brackets, installed 30 inches (.8m) above the inside base of a dust collector.

From the base junction box the Detector is circled around the interior of the outer siding then run in conduit to the center tube where the Detector is circled as shown. The Detector is then run in conduit to the top of the collector where it is supported on messenger wire in the pattern shown in Figure 23A.



Base view horizontal section

Figure 23

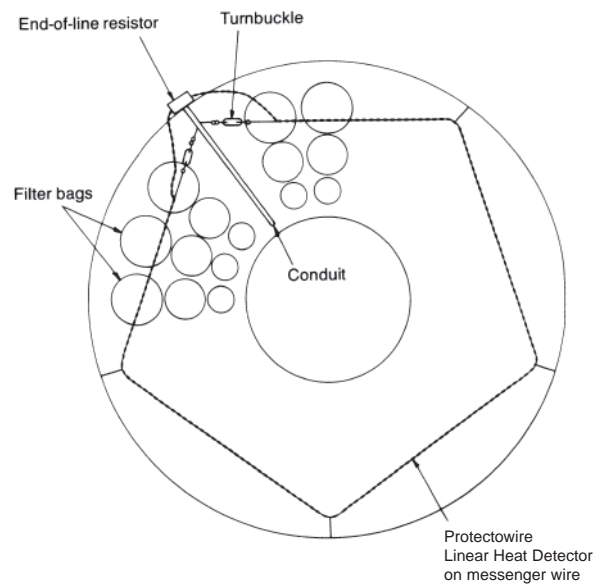

Top view horizontal section

Figure 23A

The Detector may also be installed around the blower motor frames for early detection of an overheating condition.

Open Rack Storage

Figure 24 illustrates Protectowire Linear Heat Detector installed in a section of a palletized open rack. When used in open single and double row racks protected by sprinklers, one line of detection cable is needed at each in-rack sprinkler level. Wider racks may require additional Detector runs at each level. To minimize the risk of mechanical damage to the Detector, the preferred method of mounting is to locate the Detector in the longitudinal flue space and attach it to the horizontal load beam at each sprinkler line level.

If the racks have no sprinklers and are more than 16 feet (4.9m) high the Detector should be run at two levels. If the racks are more than 32 feet (9.8m) high, the Detector should be run at three levels, etc.

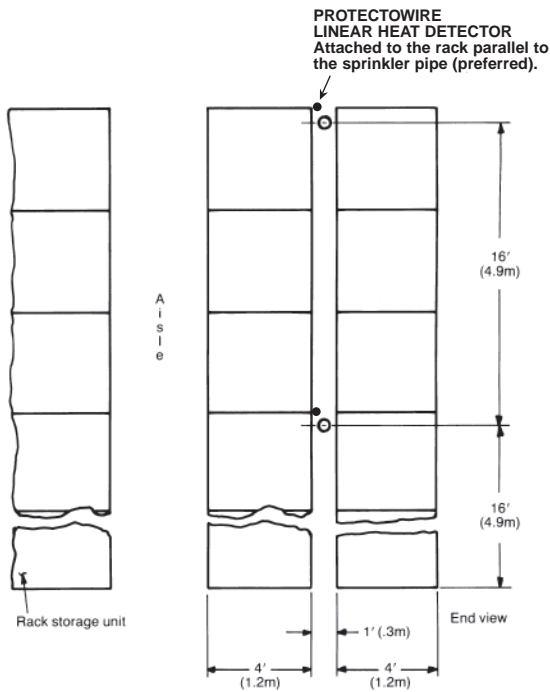

Figure 24

Floating Roof Fuel Storage Tanks

Figures 25, 25A and 25B illustrate Protectowire Linear Heat Detector installed around the perimeter of a floating roof fuel storage tank. The Detector may be run in the area between the primary tube seal and the secondary weather seal, or alternately attached to the foam dam and placed directly over the secondary weather seal. The type of mounting clip will vary according to the structure of the tank to be protected, however, the RMC Series L-Brackets are most commonly used.

ELECTRICAL DIAGRAM
 LINEAR HEAT DETECTION CIRCUITS SHALL BE APPROVED FOR HAZARDOUS LOCATION TYPE I, II, III DIV. 1 GROUPS A-G AND FM APPROVED. ALL CIRCUITS SHALL BE INSTALLED PER THE PROTECTOWIRE CO., INC. CONTROL DRAWINGS IL-1008K OR IL-1008-2F.

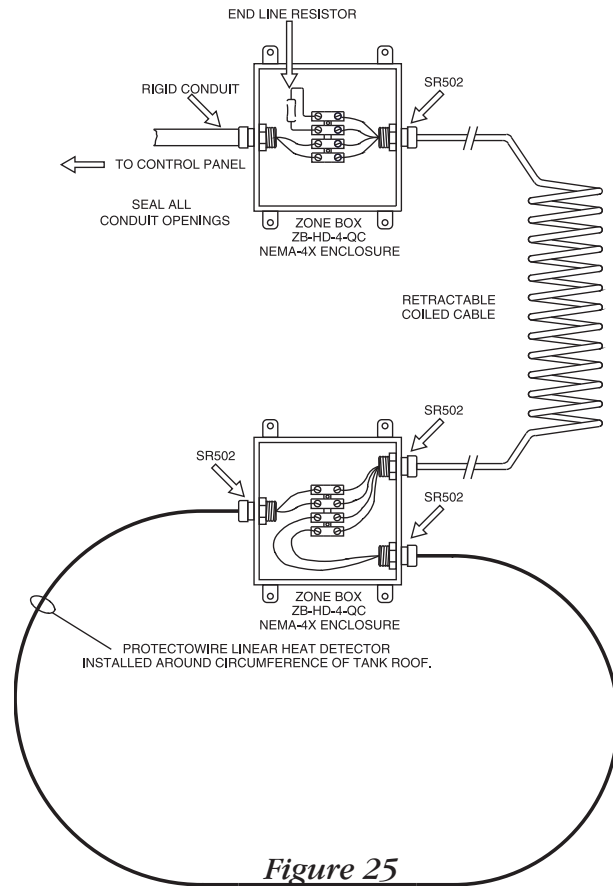

Figure 25

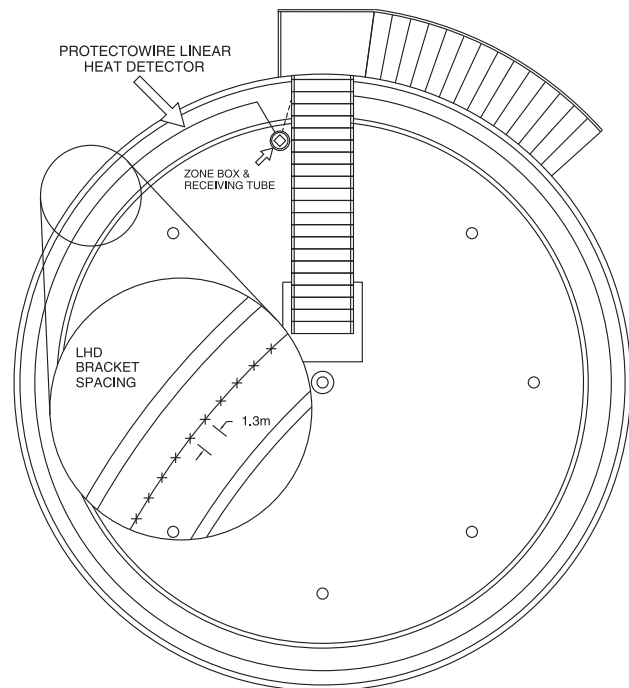

Figure 25A

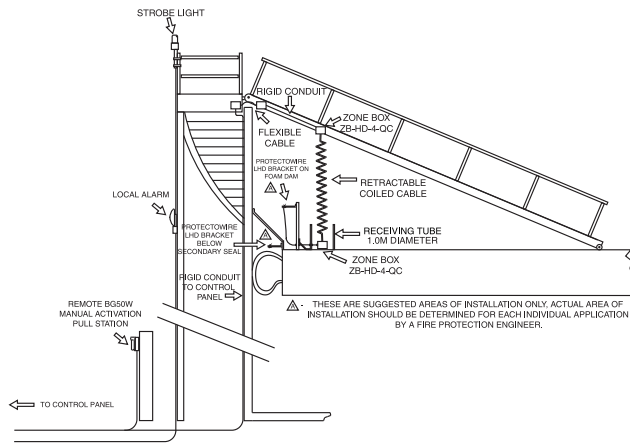

Figure 25B

Refrigerated Storage Areas

When Protectowire Linear Heat Detector is used in refrigerated storage or warehouse applications as the initiating device for pre-action sprinkler systems, Factory Mutual location and spacing guidelines are generally recommended.

Figure 26 shows the FM acceptance criteria for open area ceiling applications which requires that the Detector be installed at a spacing not exceeding the allowable ceiling sprinkler spacing.

Rack detection systems should be installed based upon the following criteria: For single row and double row racks, one line of detection cable is needed at each in-rack sprinkler level. Locate the Protectowire detection cable in the longitudinal flue space and attach it to the horizontal load beam at the sprinkler line level as illustrated in Figures 26A and 26B.

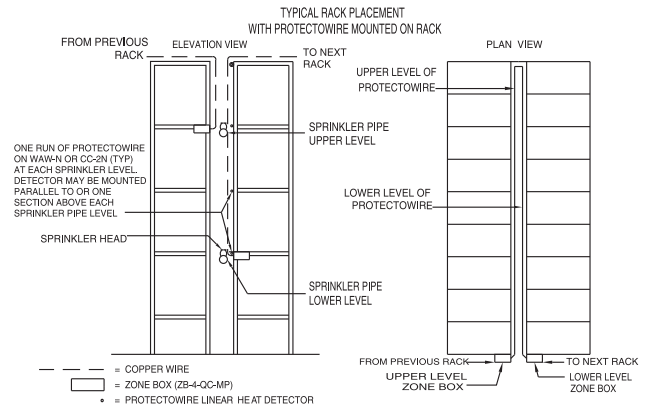

Figure 26A

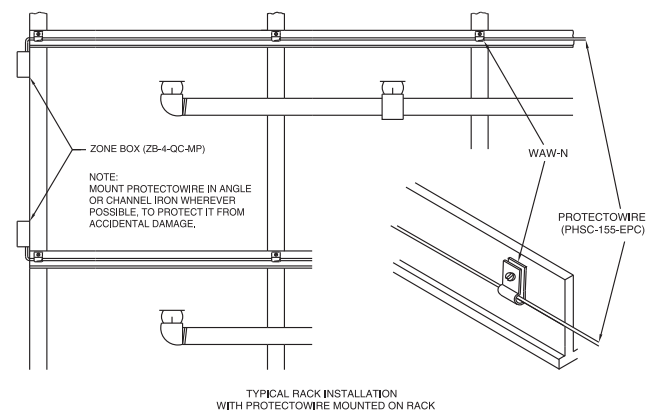

Figure 26B

For multiple-row racks, a line of detection cable is needed for each in-rack sprinkler level. Locate the detection cable in each longitudinal flue space and attach to the horizontal load beams at the sprinkler branch line levels.

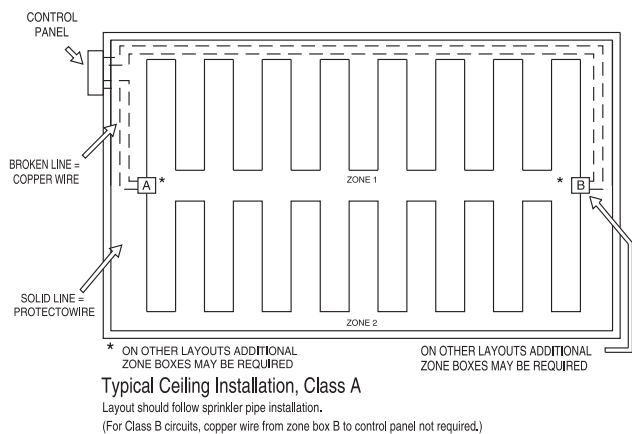

Figure 26

Installation Advisory - When Protectowire is installed in refrigerated warehouses and freezer applications, prior to chill-down, it is important to provide adequate slack or "sag" in the wire during the installation process in order to avoid excessive stress on splicing connections which may result in open circuit trouble conditions. This built-in slack is intended to compensate for the contraction of the Detector core which occurs during the reduction in temperature as the facility is brought down to its subfreezing operating temperature.

The following chart (Figure 27) shows that in a freezer with an operating temperature of -40°F (-40°C), and fasteners placed every 5 feet (1.5m), the minimum sag between each set of fasteners (as measured from the horizontal fastening plane) should be 1.125 inches (2.8cm).

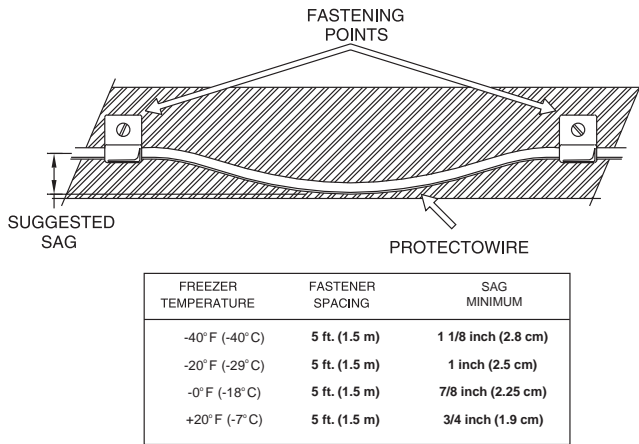

Figure 27

Figures 28 and 28A. The system's design may be further enhanced by installing Protectowire in the cable racks and equipment rooms which house control and power cables for the tunnel's ventilation, communication, and signaling equipment. In cable runs, the Detector may be installed at each rack level in direct contact with the cables. Because the Detector is a cable, it will easily follow tray runs, change levels, and cover vertical cable risers.

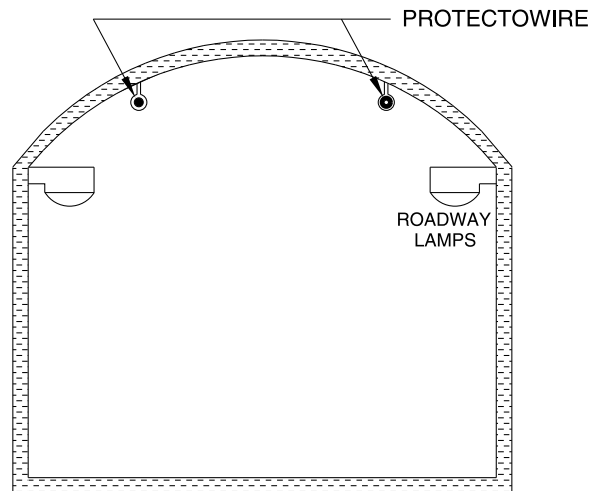

Figure 28

Tunnels

In vehicular tunnel applications, Protectowire Linear Heat Detector is typically installed on the ceiling directly over the roadway as illustrated in

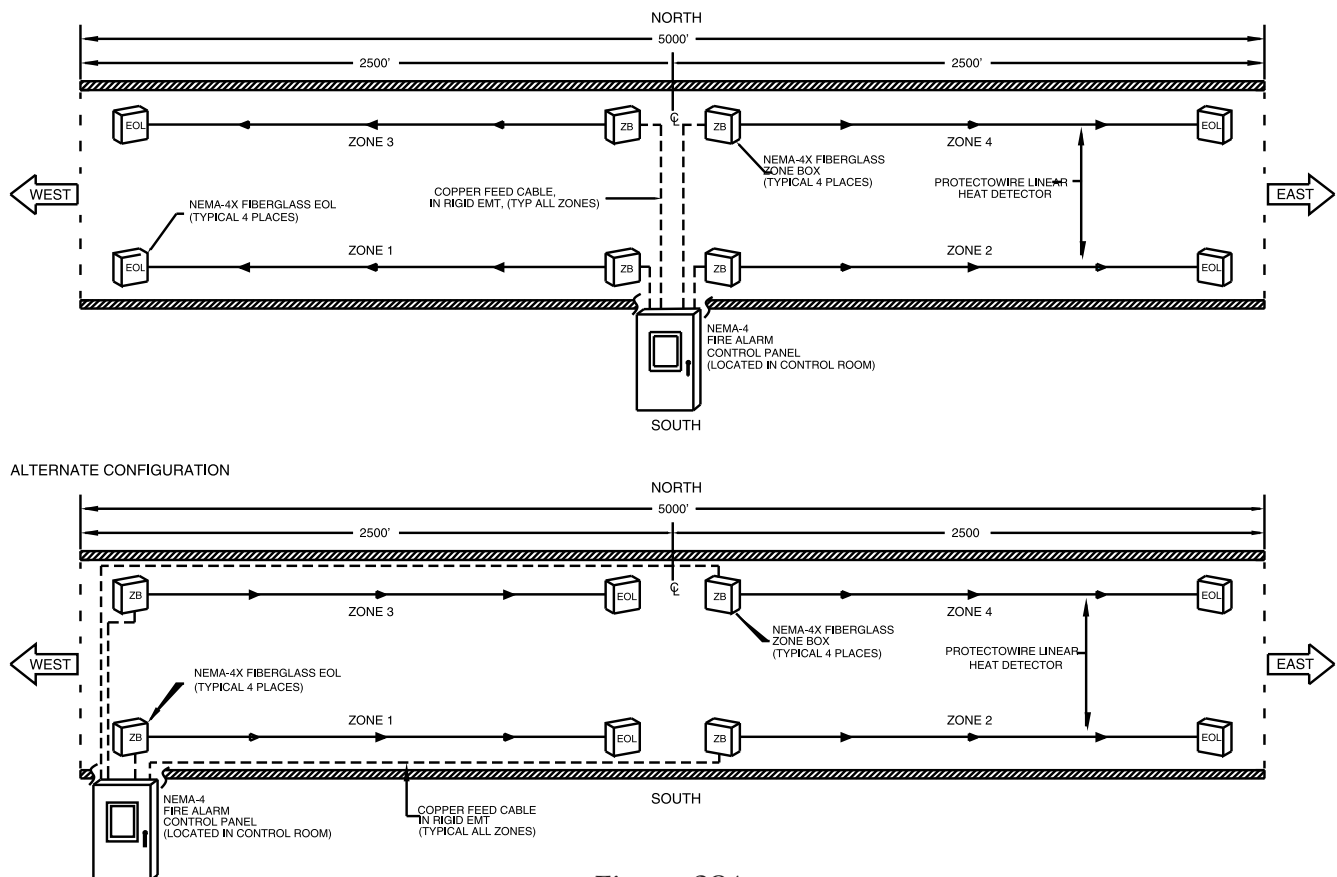

Figure 28A

Self Storage Warehouses

In self-storage facilities, Protectowire may be easily installed longitudinally in each building thereby covering each individual storage compartment. To actually isolate the alarm location, a Protectowire FireSystem Control Panel with Alarm Point Location Meter may be used. By referencing the linear distance of the alarm point displayed on the meter to the footage represented in each cubicle as noted on a facility site plan (Figure 29) mounted next to the control panel, the location of the alarm condition can be easily identified.

The special applications which have been discussed in this section of the manual, represent only a small number of the potential hazards where Protectowire may be applied. This man-

ual is intended to provide general principles only, therefore, the layout illustrations are “typical” in nature, and may require modification or adjustment based upon an actual engineering evaluation of the specific hazard and its relevant factors. If your specific application is not shown here, or if you need additional product application information or assistance, please contact The Protectowire Company.

Inspection and Testing

This section covers the minimum recommended requirements for inspection, and testing Protectowire Linear Heat Detector. In general, the requirements follow those recommended in NFPA 72 for fixed-temperature, non-restorable line type heat detectors. This manual does not cover inspection, testing or maintenance of other related devices or components of the fire alarm system.

Visual Inspection

Visual inspections of the installed system shall be made to ensure that there have been no changes to the installation site, building structure, or environmental factors that can effect equipment performance. Visual inspections shall be performed upon initial equipment installation and at least semiannually thereafter. A more frequent schedule may be used if required by the authority having jurisdiction.

Because Protectowire is frequently used in special applications where it may be inaccessible for safety considerations such as continuous process operations, or excessive height, it shall be inspected during scheduled shutdowns where approved by the authority having jurisdiction. In all cases, however, the extended interval should not exceed 18 months.

Test Frequency

As an initiating device, testing Protectowire Linear Heat Detector should be an integral part of a complete inspection and test program designed to ensure reliable operation and service of the entire fire detection/suppression system. Classified as a heat detector, Protectowire shall be tested upon initial installation and on an annual basis thereafter, unless a more frequent schedule is required by the local authority having jurisdiction.

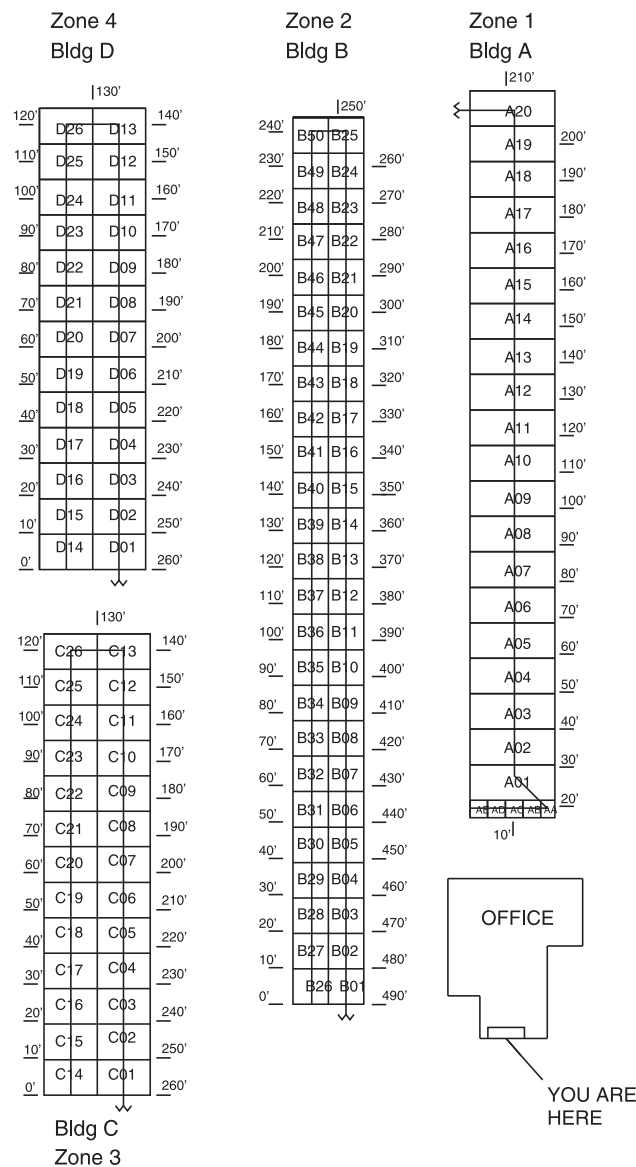

Figure 29

Testing

Inspection, testing and maintenance of all fire detection/releasing systems shall be performed only by experienced and qualified personnel. All people and facilities that receive alarm, trouble or supervisory signals shall be properly notified prior to the start of testing and again after the testing has been concluded. Suppression systems shall be secured from inadvertent actuation by disconnecting electric actuators or releasing solenoids, closing valves or taking other actions as appropriate for the specific system for the duration to the test. All system devices and releasing components must be returned to their normal condition after completion of the system testing.

Classified as a fixed-temperature, non-restorable line type heat detector, Protectowire is subject to the following test method as described in NFPA 72:

“Do not heat test. Test mechanically and electrically for function. Measure and record loop resistance. Investigate changes from acceptance test.”

This test procedure may be easily accomplished in Class B initiating circuits by using the built-in test button contained in some factory supplied end-of-line zone boxes, or by using a jumper wire to apply a short across the end-of-line resistor to create an alarm. In a Class A initiating circuit the recommended procedure is to remove the plus and minus return legs of the circuit at the control panel terminals. This action should cause a trouble signal at the control panel.

To create an alarm condition on the circuit (alarm overrides trouble), place a jumper across the disconnected return leads. This action will cause the necessary alarm condition to activate the circuit and complete the test.

To measure loop resistance, place each circuit in alarm and leave the short across the detection circuit as described above. Disconnect each detection circuit's wires from the terminals of the control panel. Place an ohm meter across the disconnected zone wires (out + and out -) and record the resistance measured. Compare these values at each annual testing. Any change in loop resistance should

be investigated for possible deterioration of the inner conductors with particular attention given to termination points, in-line splices or areas of the Detector where the outer jacket has been compromised or damaged.

In some areas, local codes or the authority having jurisdiction may require a heat test in lieu of the recommended electrical test procedure. A simple method of heat testing a non-restorable fixed-temperature linear detector, is to select a convenient location in the detection loop and using approved splicing connectors or zone boxes, install a small test length of linear detector between the splice connection points. The test area may be heated by whatever means required to satisfy the test requirements. When finished, the heat actuated section can be removed and replaced with a new piece of detector, thereby restoring the system back to normal operation.

Protectowire Test Equipment

To assist the installer and service personnel in locating heat actuated sections of the Protectowire Linear Heat Detector, or portions of the Detector which have been shorted due to mechanical damage, two portable test instruments are available from The Protectowire Company.

APL-90 Meter Adapter

The APL-90 Meter Adapter is designed to convert any Digital Multimeter which contains a 200 millivolt scale, to a Protectowire Alarm Point Location Meter. It enables the user to determine the distance of the alarm point (short) from the start of the Protectowire portion of the detection circuit. The APL-90 is housed in a high impact plastic case which measures 3.75 x 2.50 x 1 inch (9.5 x 6.4 x 2.5 cm). The unit weighs 4 ounces (113 g), and is powered by one 9 volt Type 1604 battery, which provides sufficient power for approximately 100 hours of use.

The Adapter is equipped with a standard size double banana plug with male probes spaced .75 of an inch (1.9 cm) on center. This plug provides the means to connect into a Digital Multimeter. A power ON/OFF switch, Power

On LED indicator, and Calibration Check/Test switch are also provided. A programmable micro jumper located inside the Adapter is provided so that the user may easily select either Feet or Meters as the unit of measurement to be digitally displayed.

MFL-92 Fault Locator System

The Fault Locator System is designed to detect and locate the alarm point (shorted) on the Protectowire Linear Heat Detector. Unlike the APL-90 Meter Adapter which determines the alarm location based upon conductor resistance readings which are subject to variations, the Fault Locator System is able to locate the exact location of the actuated section by using an advanced audio signaling technique.

The MFL-92 consists of two modular units. A Tone Generator Model FDG-92 and a Tone Receiver Model FDR-92. Both modules are housed in durable ABS plastic enclosures each small enough to be hand carried. Each module weighs less than 8 ounces (227 g).

The FDR-92 Tone Receiver is powered by one 9 volt Type 1604 battery with an average life of 50 hours. The unit contains a tone signal pickup LED indicator and two phone jacks. One for the exploring Pickup Head and one for an optional earphone for use in areas where the ambient noise level is high.

The second module which is the FDG-92 Tone Generator, is powered by one 9 volt Type 1604A Alkaline battery. Depending upon the load that the device is connected to, the expected battery life will range from 4 to 20 hours.

Conversion Factors

- 1 inch = 2.54 cm
- 1 foot = 3.05 decimeters
- 1 millimeter = .04 inches
- 1 centimeter = .39 inches
- 1 meter = 3.28 feet
- F° = Degrees Fahrenheit
 $F^{\circ} = \frac{9}{5}C^{\circ} + 32^{\circ}$
- C° = Degrees Celsius (Centigrade)
 $C^{\circ} = \frac{5}{9}(F^{\circ} - 32^{\circ})$

Chemical Resistance Chart for Protectowire Jacket Materials

Ratings - Chemical Effect:

A = Little or no effect

B = Minor effect

C = Moderate effect

D = Severe effect, Not recommended

Chemicals	EPC/TRI XLT	EPR	Chemicals	EPC/TRI XLT	EPR
Acetic Acid 50%	D	A	Methanol	A ¹	A
Acetone	D	A	Methyl Ethyl Ketone	D	A
Acrylonitrile	—	A	Nitric Acid (5-10%)	A ¹	B
Ammonia 10%	B ¹	A ²	Nitric Acid (20%)	A ¹	B
Ammonia, liquid	A ²	A ²	Nitrobenzene	D	A
Aniline	C ¹	A	Phosphoric Acid (<40%)	B ²	B
n-Butyl Acetate	D	A	Potassium Hydroxide 10%	A ¹	A
Diethylene Glycol	A	A ²	Propanol	—	A
Diethylether	—	A	Sea Water	A ²	A
Ethanol	—	A	Sodium Chloride	A ²	A
Ethylene Glycol	A ¹	A	Sodium Hydroxide 50%	A	A
Gasoline	C ¹	C ¹	Sulfuric Acid (<10%)	A ¹	A
Glycerol	—	A	Sulfuric Acid (75-100%)	D	A
Hexane	B ¹	A	Water, Fresh	A ²	A ²
Hydrochloric Acid 10%	A ²	A	Zinc Chloride 10%	A ²	A
Hydrogen Sulfide (aqua)	B ¹	A ¹	<u>Oils:</u>		
			Diesel Fuel	A ²	B
			Fuel	A ²	B
			Hydraulic Oil	A	A

Explanation of Footnotes:

¹Satisfactory to 72°F (22°C)

²Satisfactory to 120°F (49°C)

All information supplied in these Chemical Resistance Charts by The Protectowire Company in relation to its products and their application is intended for general reference only. The information is not a guarantee of product performance or a recommendation for product use in the environments indicated. The Protectowire Company, assumes no liability whatsoever in respect to application, or use made of the aforementioned information or products, or any consequence thereof.

Chemical Resistance Chart **For Protectowire Type XCR Jacket Material**

This chemical resistance chart cannot predict the effect on the jacket of complex chemical mixtures. The appropriate chemical resistance tests using a representative sample of the chemical(s) or a trial installation of the Protectowire Linear Heat Detector should be performed to determine acceptable product performance.

Chemical	Formula	Concentration	Max. Temp. [°C]
Acids			
Hydrochloric	HCl	37%	150
Hydrofluoric	HF	50%	150
Nitric	HNO ₃	65%	66
Phosphoric	H ₃ PO ₄	85%	150
Sulphuric	H ₂ SO ₄	98%	23
Bases			
Ammonium hydroxide	NH ₄ (OH)	30%	150
Potassium hydroxide	KOH	30%	121
Sodium hydroxide	NaOH	50%	121
Sodium hypochlorite	NaClO	5%-stabilized at pH 12	150
Hydrocarbons			
n-Hexane	CH ₃ (CH ₂) ₄ CH ₃	100%	150
Toluene	C ₆ H ₅ CH ₃	100%	66
Alcohols and Ethers			
Methanol	CH ₃ OH	100%	65
Ethanol	CH ₃ CH ₂ OH	100%	140
Organic Acids, Esters and Ketones			
Acetic acid	CH ₃ COOH	100%	>100
		50%	>121
Acetone	CH ₃ COCH ₃	100%	66
Acetophenone	C ₆ H ₅ COCH ₃	100%	50
Ethyl Acetate	CH ₃ COOCH ₂ CH ₃	100%	50
Classic Polymer Solvents			
Dimethyl formamide	CH ₃ CON(CH ₃) ₂	100%	50
Dimethyl sulphoxide	CH ₃ SOCH ₃	100%	>100
N-Methylpyrrolidone		100%	25
Halogenated Solvents			
Chlorobenzene	C ₆ H ₅ Cl	100%	66
Chloroform	CHCl ₃	100%	Not resistant
Amines and Nitriles			
Acetonitrile	CH ₃ CN	100%	>100
Aniline	C ₆ H ₅ NH ₂	100%	100
Dimethyl amine	(CH ₃) ₂ NH	100%	25
Peroxides			
Hydrogen peroxide	H ₂ O ₂	30%	>88
Automotive Fluids			
Crude Oil		100%	150
Dexron II (gear oil)		100%	150
Gasoline		100%	150
Diesel Fuels		100%	150
Mineral Oil		100%	150

The maximum recommended temperatures listed in the XCR Chemical Resistance Chart refers to the point at which the chemicals indicated would damage the jacket material. These temperatures have no relationship to the alarm temperature of the Detector, but should be referenced to determine if limitations to the maximum recommended ambient temperature for the Detector is necessary in chemical environments. Any breach or adverse chemical effect on the integrity of the Protectowire jacket, will lead to premature detector failure and a reduced service life for the product.

Protectowire Linear Heat Detector

TYPE EPC – VINYL JACKET



PHSC-155-EPC 155° (68°C)
Max. Recommended Ambient Temp 115° F (46° C)



PHSC-190-EPC 190° (88°C)
Max. Recommended Ambient Temp 150° F (66° C)



PHSC-220-EPC 220° (105°C)
Max. Recommended Ambient Temp 175° F (79° C)



PHSC-280-EPC 280° (138°C)
Max. Recommended Ambient Temp 200° F (93° C)



PHSC-356-EPC 356° (180°C)
Max. Recommended Ambient Temp 221° F (105° C)

TRI-WIRE™ DUAL TEMPERATURE VINYL JACKET



PHSC-6893-TRI 155°/200° (68°/93°C)
Max. Recommended Ambient Temp 115° F (46° C)

TYPE XCR FLUOROPOLYMER JACKET



PHSC-155-XCR 155° (68°C)
Max. Recommended Ambient Temp 115°F (46°C)



PHSC-190-XCR 190° (88°C)
Max. Recommended Ambient Temp 150°F (66°C)



PHSC-220-XCR 220° (105°C)
Max. Recommended Ambient Temp 175°F (79°C)



PHSC-280-XCR 280° (138°C)
Max. Recommended Ambient Temp 200°F (93°C)



PHSC-356-XCR 356° (180°C)
Max. Recommended Ambient Temp 250°F (121°C)

TYPE EPR –

POLYPROPYLENE ELASTOMER JACKET



PHSC-155-EPR 155° (68°C)
Max. Recommended Ambient Temp 115° F (46° C)

PHSC-190-EPR 190° (88°C)
Max. Recommended Ambient Temp 150° F (66° C)

PHSC-280-EPR 280° (138°C)
Max. Recommended Ambient Temp 200° F (93° C)

PHSC-356-EPR 356° (180°C)
Max. Recommended Ambient Temp 250° F (121° C)

TYPE XLT – PROPRIETARY POLYMER JACKET



PHSC-135-XLT 135° (57°C)
Max. Recommended Ambient Temp 100° F (38° C)

Installation hardware

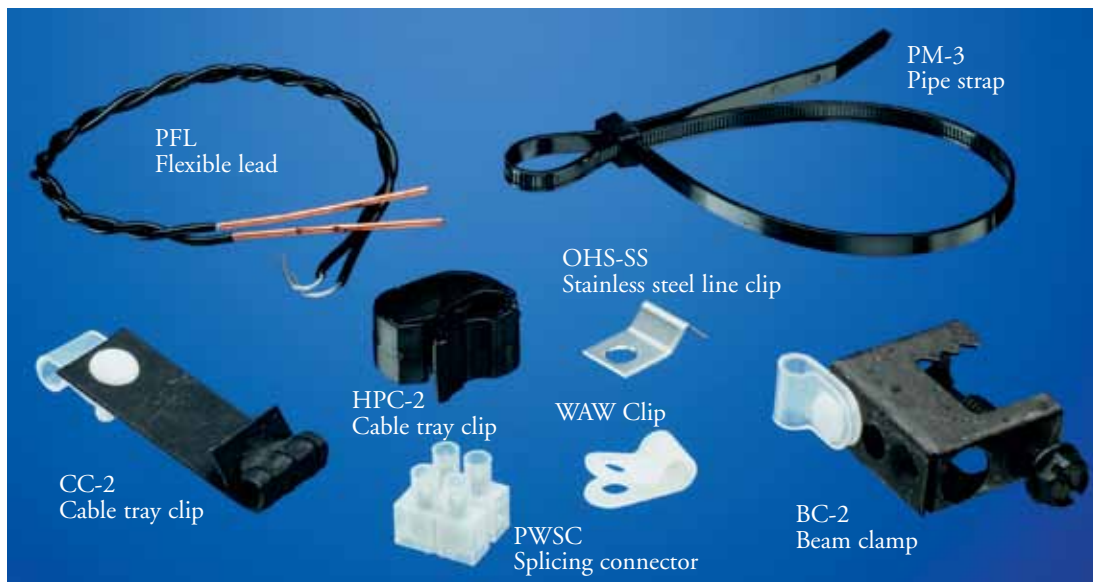

PROTECTOWIRE[®] *FireSystems*

The Protectowire Company, Inc.
40 Grissom Road, Plymouth, MA 02360-7205 U.S.A.
781-826-3878; Fax 781-826-2045
Website: www.protectowire.com; E-mail: pwire@protectowire.com

Manufacturer of
Special Hazard
Fire Detection Systems

