

SM12 & SM16

STEREO MIC/LINE MIXING CONSOLES
OPERATION MANUAL

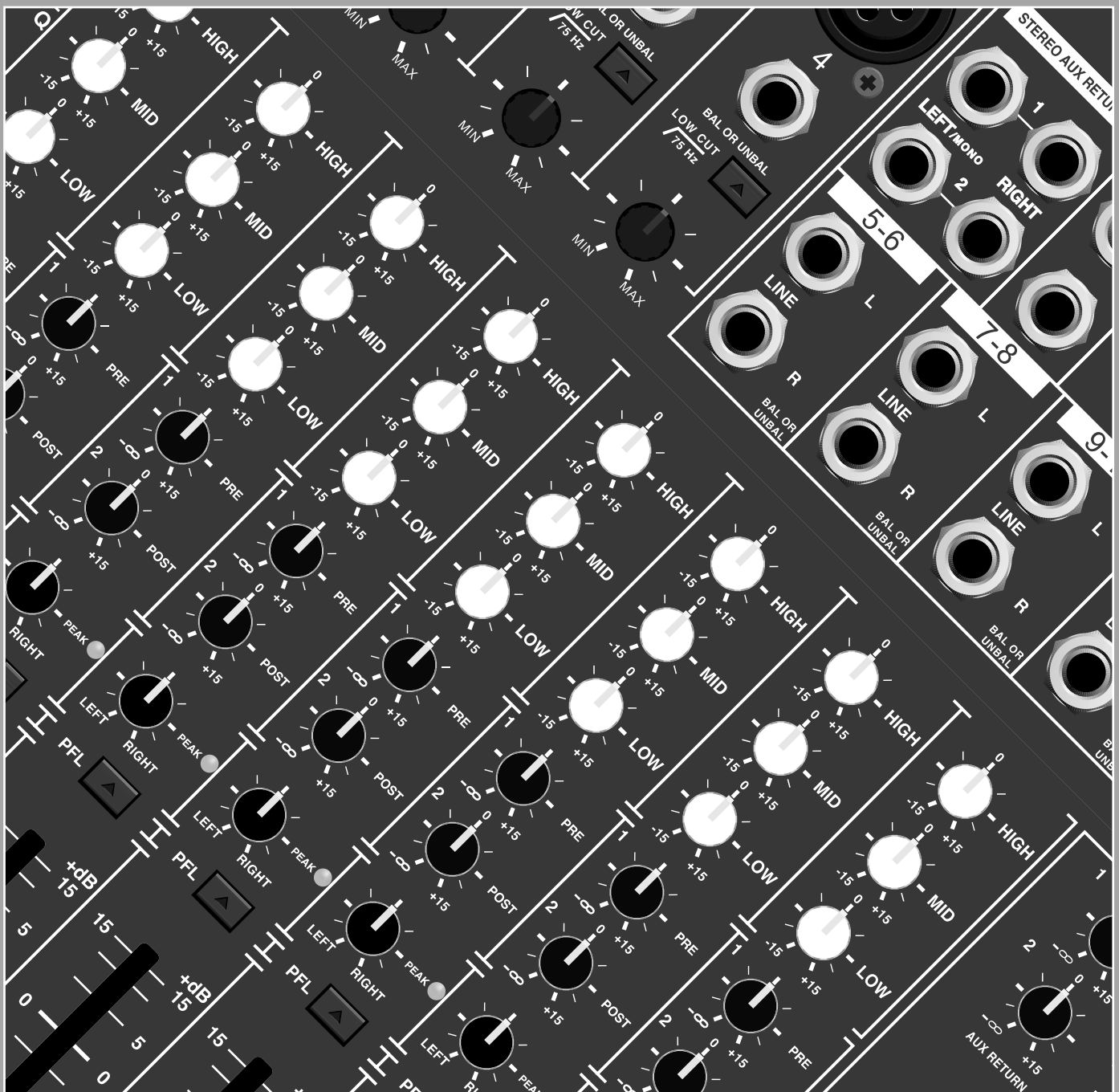

INTRODUCTION AND CONTENTS

The Australian Monitor Pro Series SM12 and SM16 stereo console mixers are designed to be compact, ultra low noise and feature packed.

With a mixture of mono channels featuring balanced XLR or TRS inputs and switchable 48V phantom power, and stereo channels all boasting 3 stage EQ and pre and post fader auxiliary sends, the SM series mixers are as versatile as they are cost effective.

The SM Series mixers feature peak LED indication and low cut filters on all mono channels, high quality 60mm faders and sealed potentiometers, 19 inch rack mount kit and accurate 10 segment bar graph meters for the stereo output buss.

The Australian Monitor Pro Series SM12 and SM16 give the audio professional a sonically superior mixing console offering a feature set and versatility usually found in mixing consoles many times their price.

INTRODUCTION	3
MONO CHANNELS	4
STEREO CHANNELS	5
MASTER SECTION	6
REAR PANEL	7
OPERATION	8
BLOCK DIAGRAM	9
SPECIFICATIONS	10

AUS, EUR, USA
Copyright 17th Oct 2004
Rev A: 17th Oct 2004

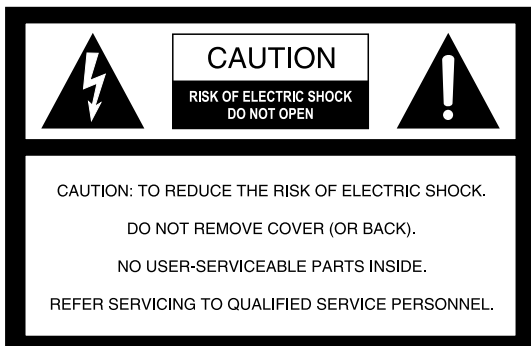

WARNING !

TO REDUCE THE RISK OF FIRE OR ELECTRIC SHOCK.
DO NOT EXPOSE THIS EQUIPMENT TO RAIN OR MOISTURE.



This symbol is intended to alert the user to the presence of uninsulated "dangerous voltage" within the product's enclosure that may be of sufficient magnitude to constitute a risk of electric shock to persons.



This symbol is intended to alert the user to the presence of important operation and maintenance (servicing) instructions in the literature accompanying the appliance.

Caution:

To prevent electric shock do not use this (polarised) plug with an extension cord, receptacle or other outlet unless the blades can be fully inserted to prevent blade exposure. To prevent electric shock, match wide blade of plug to wide slot, fully insert.

MONO CHANNELS

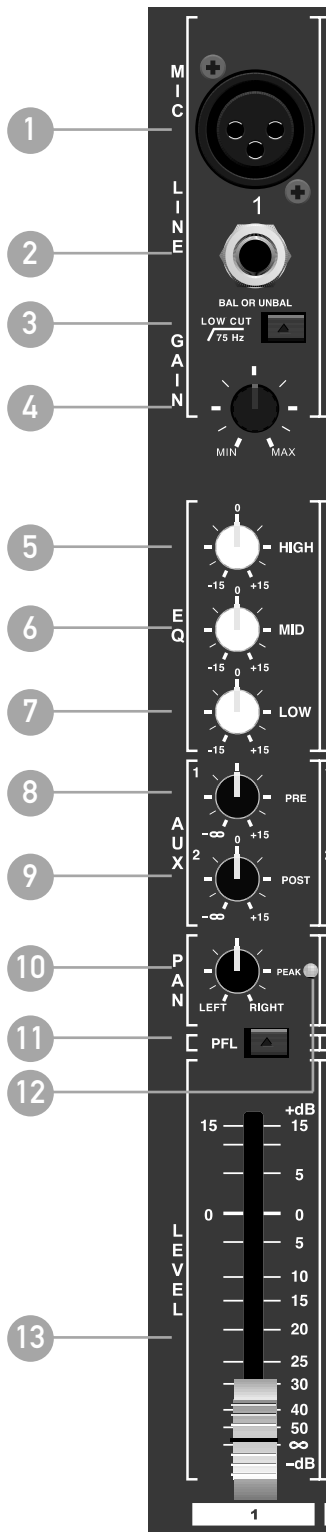

MIC/LINE INPUT SECTION

- 1 MIC**
Balanced XLR input

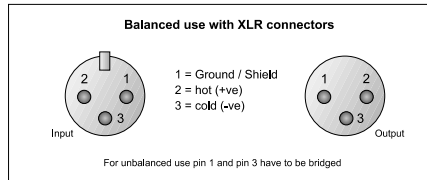

- 2 LINE**
6.35mm TRS input

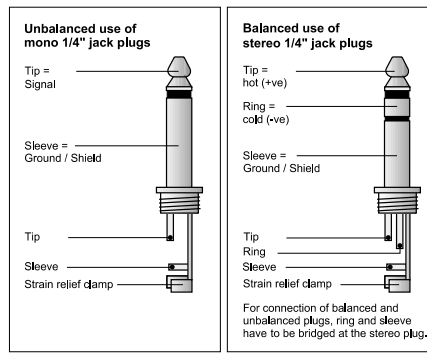

- 3 LOW CUT FILTER SWITCH**
This switch will roll off frequencies below 75Hz at an 18dB per octave slope. This can be used to eliminate rumble caused by sensitive lectern mics etc.

- 4 GAIN**
This is the initial gain control for each input and should be set to optimise each inputs level while still leaving headroom so the input signal does not reach clipping level. This gain stage has a range from +10dB to +60dB.

EQ SECTION

- 5 HIGH**
This is a shelf EQ filter that adjusts treble frequency levels and will give up to 15dB of boost or cut at 12kHz. The centre position will give a flat response.

- 6 MID**
This mid range EQ control adjusts mid range frequencies and has a fixed 2 octave bandwidth at 2.5kHz. This control will give up to 15dB of boost or cut. The centre position will give a flat response.

- 7 LOW**
This low frequency shelf EQ control adjusts bass frequencies and will give up to 15dB of boost or cut at 80Hz. The centre position will give a flat response.

AUXILIARY SECTION

- 8 PRE**
Aux 1 is a mono split of the channel input signal and is post EQ but pre the channel fader.

- 9 POST**
Aux 2 is a mono split of the channel input signal and is post EQ and post channel fader.

- 10 PAN**
The channel pan control is used to position the channel signal in the stereo field.

- 11 PFL**
The Pre Fader Listen (PFL) switch is used to monitor the input signal before the channel fader. This can be switched to either the headphone/local monitor output or the master left/right outputs (see master section)

- 12 PEAK LED**
This red LED illuminates when the channel is going into overload (clip)

- 13 LEVEL**
This channel output fader adjusts the level of the channels signal before it is sent to the master output buss.

STEREO CHANNELS

LINE INPUT SECTION

14 LINE L/R

These 6.35mm TRS jacks will accept either balanced or unbalanced line level signals. For mono operation use left input only.

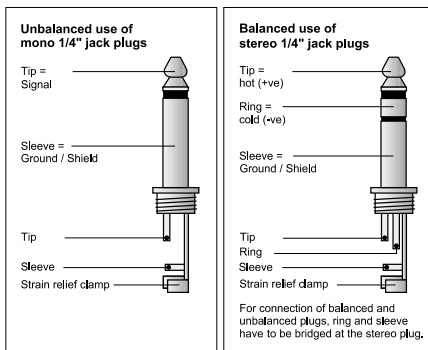

EQ SECTION

15 HIGH

This is a stereo shelf EQ filter that adjusts treble frequency levels and will give up to 15dB of boost or cut at 12kHz. The centre position will give a flat response.

16 MID

This stereo mid range EQ control adjusts mid range frequencies and has a fixed 2 octave bandwidth at 2.5kHz. This control will give up to 15dB of boost or cut. The centre position will give a flat response.

17 LOW

This low frequency stereo shelf EQ control adjusts bass frequencies and will give up to 15dB of boost or cut at 80Hz. The centre position will give a flat response.

AUXILIARY SECTION

18 PRE

Aux 1 is a mono split of the channel input signal and is post EQ but pre the channel fader.

19 POST

Aux 2 is a mono split of the channel input signal and is post EQ and post channel fader.

20 PAN

The channel pan control is used to position the channel signal in the stereo field. This differs from the mono channels as this pan control will determine the level of either the Left or Right buss that is sent to the master mix. For example if the pan control is turned fully clockwise, only the Right signal path will be sent to the master mix. If the Left input only is connected (a mono signal) the pan control will work as per the mono channels.

21 PEAK LED

This red LED illuminates when the channel is going into overload (clip)

22 PFL

The Pre Fader Listen (PFL) switch is used to monitor the input signal before the channel fader. This can be switched to either the headphone/local monitor output or the master left/right outputs (see master section)

23 LEVEL

This Channel output fader adjusts the level of the channels signal before it is sent to the Master output buss.

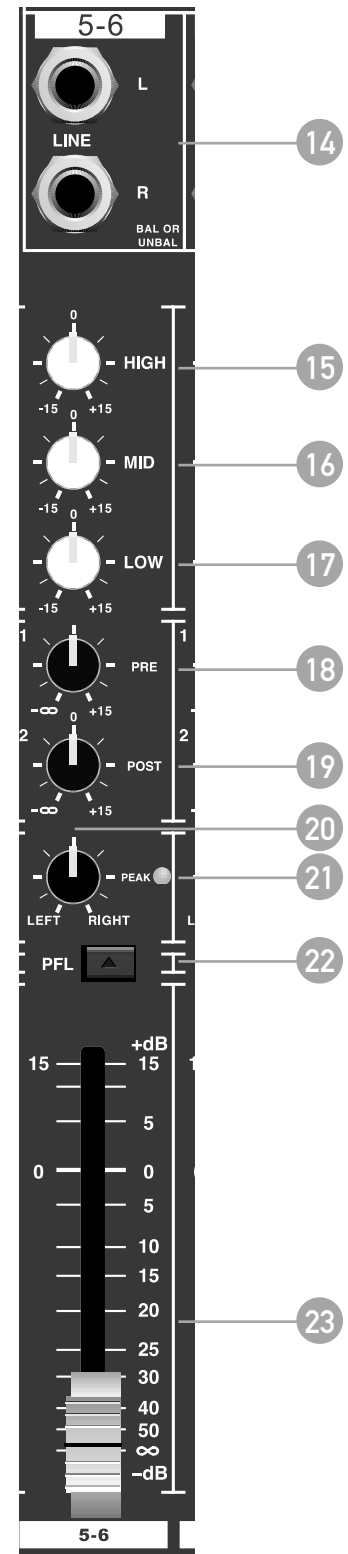

MASTER SECTION

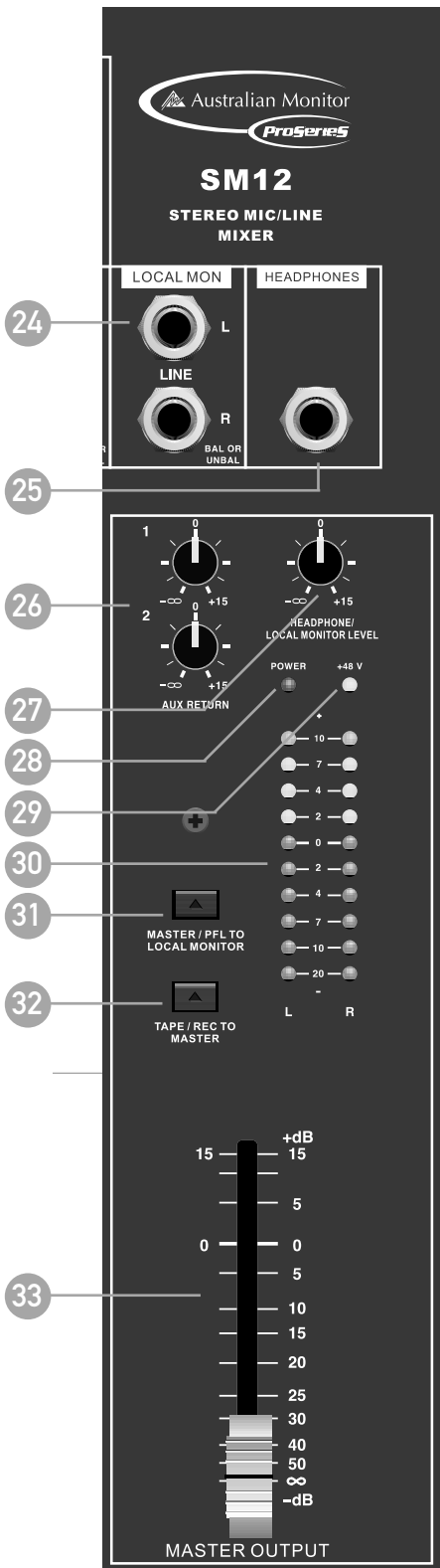

24 LOCAL MON

These TRS 6.35mm jacks provide a stereo output that can be sent to a local monitor amp and speakers for control room or bio box monitoring of either the PFL buss or the master output buss.

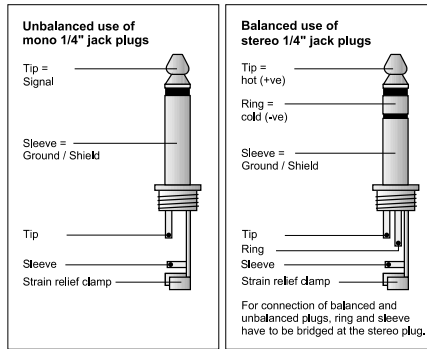

25 HEADPHONES

This is a monitor output for headphones. This outputs signal will follow whatever is assigned to the Local Monitor output.

26 AUX RETURN 1/2

These controls adjust the level of the stereo auxiliary returns. Both Aux Return 1 & 2 are permanently assigned to the Master Mix.

27 HEADPHONE/LOCAL MONITOR LEVEL

This control adjusts the output level of the Local Monitor outputs and the Headphone

output. This level is independent of the Master Mix.

28 POWER LED

This LED indicates that the mixer is "on"

29 +48V

This LED indicates that 48 volt phantom power is active.

30 L/R OUTPUT METER

The Master Output level is displayed on these 10 segment Bar Graph peak meters.

31 MASTER/PFL TO LOCAL MONITOR

This switch determines whether the Master mix signal or the PFL signal will be sent to the Local Monitor/Headphone output.

32 TAPE/REC TO MASTER

This switch determines whether a tape or other stereo source connected to the Tape In RCA connectors is sent to the Master Mix.

33 MASTER OUTPUT

This fader controls the master output level of both the Left and Right busses to the master XLR and TRS outputs of the mixing console.

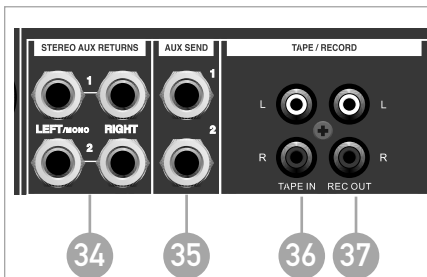

35 AUX SEND 1/2

These unbalanced 6.35mm jacks can be used to send the output of each channels Aux sends to effects devices such as reverb or delay units.

36 L/R TAPE IN

These stereo RCA connectors allow connection of a tape deck, CD/DVD player etc to the mixer and are routed to the Master Mix.

37 L/R RECORD OUT

These stereo RCA connectors allow for a tape deck or digital recorder to be connected to mixing console for recording the output of the Master Mix.

34 STEREO AUX RETURNS 1/2

These 2 additional stereo inputs can be used for the return of stereo effects units such as reverb or delay units and are permanently assigned to the Master Mix. These can also be used as extra line level inputs and can be mono if only the left input is used.

WARNING!

TO REDUCE THE RISK OF FIRE OR ELECTRIC SHOCK, DO NOT EXPOSE THIS PRODUCT TO RAIN OR MOISTURE. DO NOT REMOVE CHASSIS (OR BACK). NO USER SERVICEABLE PARTS INSIDE. REFER SERVICING TO QUALIFIED SERVICE PERSONNEL.

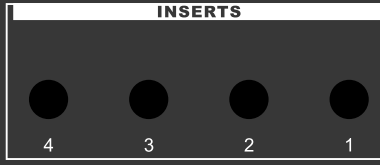

38 INSERTS 1-4 (1-8 ON THE SM16)

An insert point is provided for each Mono Channel on the SM12 and SM16 mixing consoles. These insert points are a split of the channels input signal which is post input gain and Low cut filter with the return path pre EQ. These inserts are 6.35mm TRS sockets with Tip being send and ring being return.

Balanced use of stereo 1/4" jack plugs

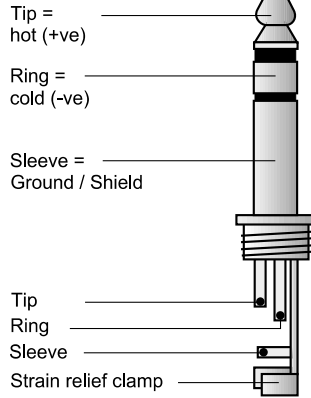

For connection of balanced and unbalanced plugs, ring and sleeve have to be bridged at the stereo plug.

Tip = Send, Ring = Return



- 39
- 40
- 41

39 POWER
This switch turns mains power "on" to the mixer

40 AC POWER
This is the connection for the supplied AC power supply.
⚠ Please use supplied mains power supply only. Always connect the power supply to the mixer before connecting to the mains supply.

- 42

41 PHANTOM
This switch turns 48 volt phantom power "on" to all mono channels. Phantom power is required for Electret or Condenser style microphones

42 STEREO OUT
Both balanced XLR and 6.35mm TRS jacks are included and provide Stereo mix output at the level set by the Master output fader. Both sets of outputs can be used simultaneously.

OPERATION

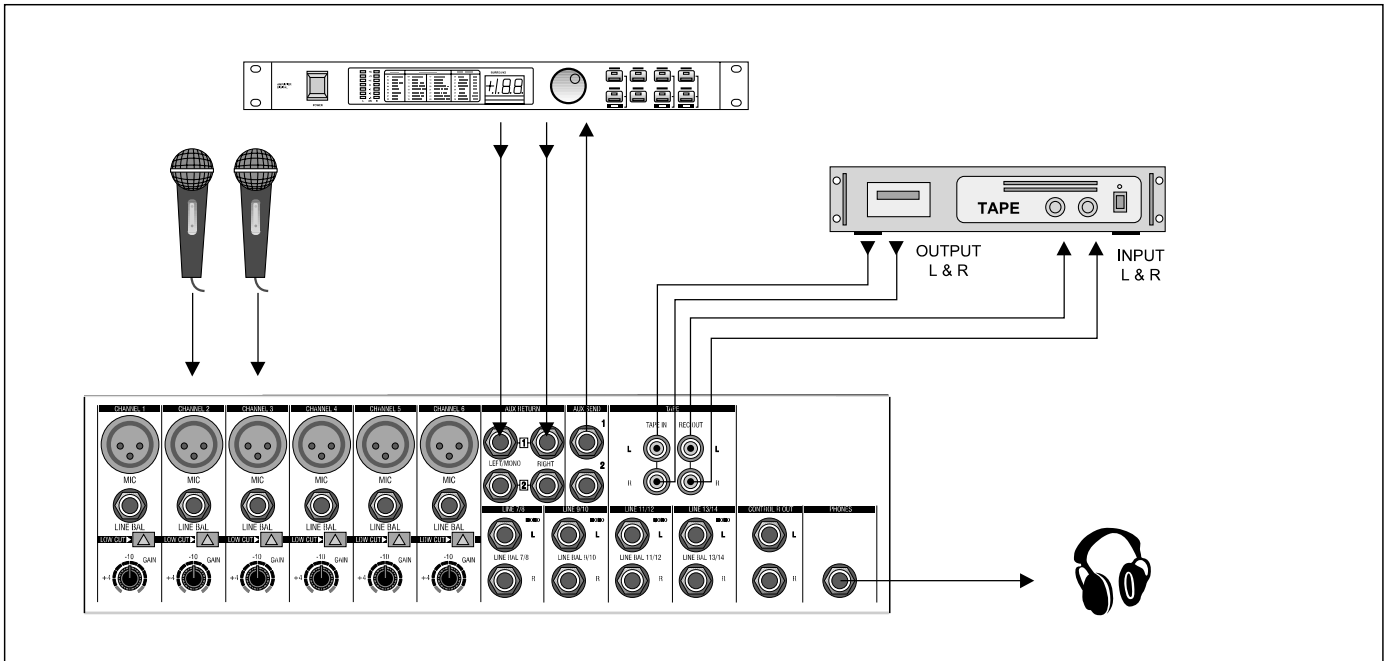

Before connecting any input sources to your SM12 or SM16 stereo console mixer, please make sure the following initial settings are correct.

- All gain controls and faders are set to minimum
- All Auxiliary sends are set to minimum
- EQ is set flat (i.e. in centre position)
- Ensure the power supply is correctly connected
- No PFL's are active

Connect mic or line source to desired channel inputs (make sure phantom power is switched on if required) and ensure Master Outputs are correctly connected to your audio system.

- 1 Set the Master Output to unity gain (set to "0")
- 2 Turn up the input gain for your selected channel to 12 O'clock (half way)
- 3 Generate input signal (i.e. voice for a microphone, play background source etc)
- 4 Ensure the selected channels Peak LED is not illuminating
- 5 Raise the selected channels fader till the desired level is achieved
- 6 The L/R Output meter should be continuously metering at up to 0dB with any transient signals not exceeding the +6dB indicator.
- 7 Adjust input gain stage to ensure correct gain settings
- 8 EQ input signals as required remembering that boosting frequencies will add to the signals gain.
- 9 Repeat for remaining channels



NOTE: A full discussion of setting up a complex system with correct gain structure is beyond the scope of this manual. The procedure above assumes that the installer has correctly set up external equipment connected to this mixer prior to initiating the setup procedure.

BLOCK DIAGRAM

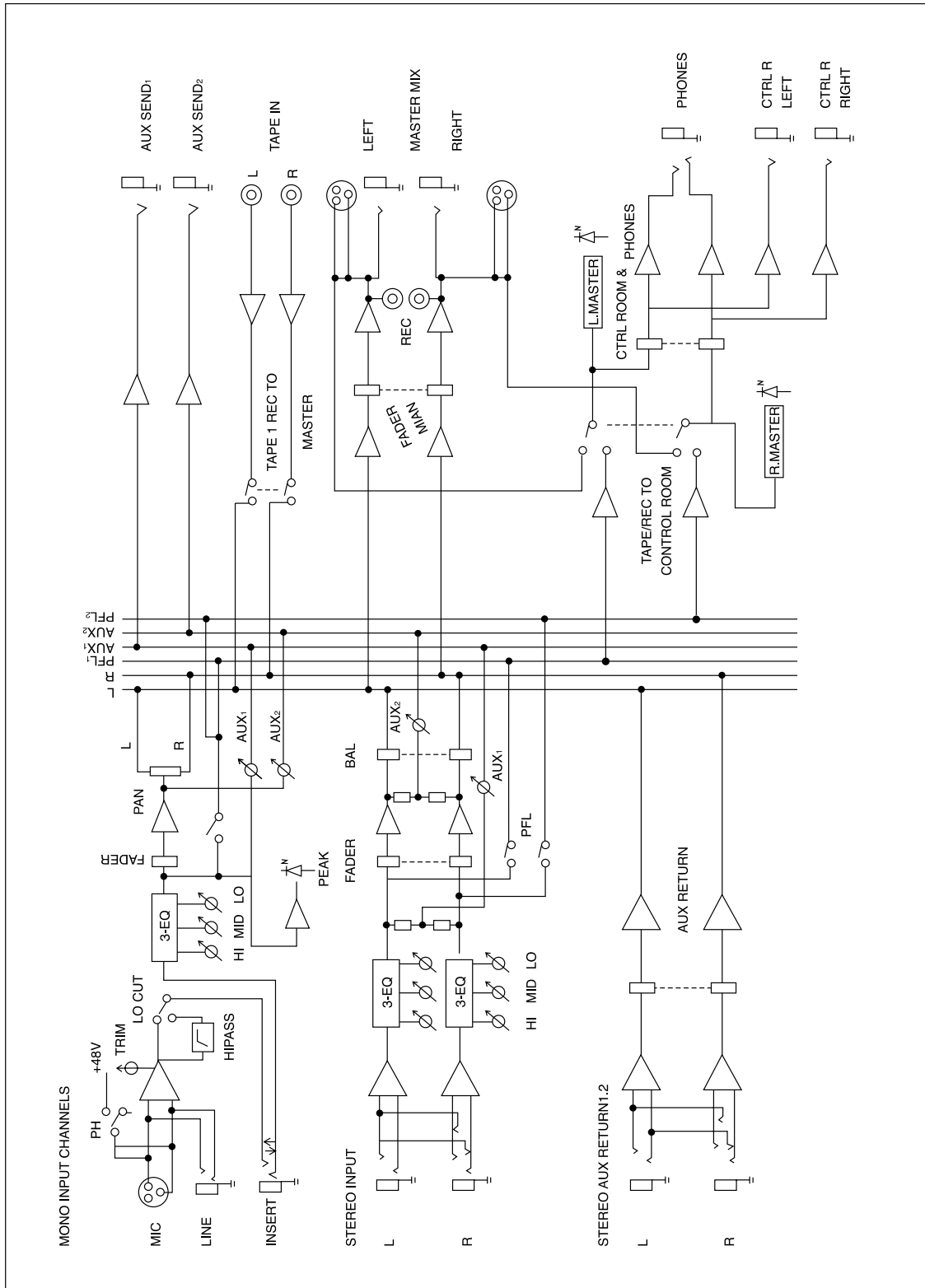

SPECIFICATIONS

MONO INPUTS

Mic Input	Electronically balanced, discrete input configuration
Bandwidth	10Hz to 60kHz \pm 3dB
Distortion (THD & N)	0.01% at +4dBu, 1kHz, Bandwidth 80kHz
Mic E.I.N. (22Hz - 22kHz)	-129.5dBu, 150 Ω source -117.3dBqp, 150 Ω source -132.0dBu, input shorted -122.0dBqp, input shorted
GAIN range	+10dB to +60dB

Line Input	Electronically balanced
Bandwidth	10Hz to 60kHz \pm 3dB
Distortion (THD & N)	0.01% at +4dBu, 1kHz, Bandwidth 80kHz
Line Level Range	+10dBu to -40dBu

Equalisation	
Hi Shelving	12kHz \pm 15dB
Mid Range	2.5kHz \pm 15dB
Lo Shelving	80Hz \pm 15dB

STEREO INPUTS

Line Input	Unbalanced
Bandwidth	10Hz to 55kHz \pm 3dB
Distortion (THD & N)	0.01% at +4dBu, 1kHz, Bandwidth 80kHz

Equalisation	
Hi Shelving	12kHz \pm 15dB
Mid Range	2.5kHz \pm 15dB
Lo Shelving	80Hz \pm 15dB

MASTER MIX SECTION

Max. Output	+22dBu Balanced
Aux. Send Max. Out	+22dBu Unbalanced
Control Room Out	+22dBu Unbalanced
Signal-to-Noise Ratio	112dB, all channels at Unity Gain

POWER SUPPLY (mains voltages)

USA/Canada	-115VAC, 60Hz, power supply unit MXUL2 (included)
Europe/Australia	-230VAC, 50Hz, power supply unit MXUK2 (included)

PHYSICAL

SM12	
Dimensions (H x W x D)	70mm x 293mm x 344mm
Net Weight	3.6kg (PSU not included)
Gross Weight	5.8kg

SM16	
Dimensions (H x W x D)	70mm x 399mm x 344mm
Net Weight	5kg (PSU not included)
Gross Weight	8.0kg

