

INTRODUCTION

Congratulations! You have purchased one of the most sophisticated cordless telephones on the market! The VT 1923 has been designed to offer a new standard in cordless telephone technology.

Unlike most other cordless phones, the VT 1923 digitizes your voice using advanced ADPCM digital voice coding to provide noise and distortion free performance. In most conditions you will not be able to tell you are using a cordless phone. Gone are the annoyances of static, interference and having to listen to other people's conversations on your cordless phone.

The VT 1923 scrambles your voice before it transmits it. This allows you the security of knowing that no one can tune in and eavesdrop on your conversations.

The VT 1923 decodes and displays name and/or number Caller ID (CID) information where available and when subscribed to. The alpha-numeric display can show both the name and number of the calling party. Up to 24 name characters or 11 phone number digits can be displayed on the LCD.

With the VT 1923, the user can easily answer a call by pressing any key other than the OFF, MUTE or VOLUME Keys. In addition, the Handset keypad

and LCD illuminate while the Handset rings to signal an incoming call. This is very useful in a dark environment. The VT1923 also provides a one-way Page/Find. Pressing the Base PAGE key will cause the Handset to ring in a manner which distinguishes it from normal incoming ringing. This can be used to alert the Handset user, or to simply locate the Handset in the event that it is misplaced.

The VT 1923 uses special memory in both the Base and Handset which is not susceptible to power failures. This provides permanent storage of all memory dial numbers, CID information as well as the Base and Handset security codes.

When an optional battery pack is installed in the Base unit, the VT 1923 uses this battery pack to provide operational backup in case of power failure. In this way you have access to all normal phone functions during a total power outage. Calls can still be placed and received without interruption. More than 5 hours backup will be possible with a fully charged battery pack in the Base unit.

The VT 1923 informs you that another extension is currently in use on the same phone line. The phone will also alert you when you are Out of Range, even when you're not using the phone!

INTRODUCTION

Special Features

- 900 MHz Operation.
- Fully Digital Link between Handset and Base with ADPCM voice coding.
- Digitally-Scrambled Voice Communication.
- Name / Number CID display.
- 2 row by 12 character 5x7 dot matrix alpha-numeric LCD.
- 50 CID memory locations.
- Backlit LCD on the Handset
- Backlit Handset display.
- 20 location Programmable Memory for 20 Digit Phone Number.
- 10 Channel Operation with auto channel selection.
- Out-of-Range indication while the Handset is in use or in standby mode.
- Removable Handset battery pack.
- Spare battery charger in the Base Unit.
- Complete battery back-up in case of power failure (with optional spare battery pack installed in Base).
- Face-up Handset charging.
- Easy answer - When the phone rings, simply press any key other than OFF, MUTE, or the Volume Keys on the Handset to answer.
- Auto hang up when returning the Handset to the Base cradle.
- Extension in use indicator.
- 24 Bit Digital Security Code
- DTMF and Pulse Dialing.
- Low Battery Detect and Warning indicator.
- Up to 7 hours continuous talk time or 7 days standby time.
- Volume Adjust on Handset.
- REDIAL, HOLD, PAGE and MUTE.
- Hearing-Aid Compatible Receiver.
- Detachable power supply.
- Non-volatile storage of security code and memory dial records.
- Programmable Ringer Types.

This manual is designed to make you familiar with the VT 1923. We strongly recommend you read the manual before using your phone.

INTRODUCTION

Parts Check List

1. Handset
1. Base Unit
1. AC Power Adapter
2. One-Line Telephone Cord
3. Battery Pack
4. Wall mount accessory
5. Belt clip
6. Owner's Manual

To purchase replacement battery packs, call VTECH Communications at 1-800-595-9511. In Canada, call VTECH Electronics at 1-800-267-7377.

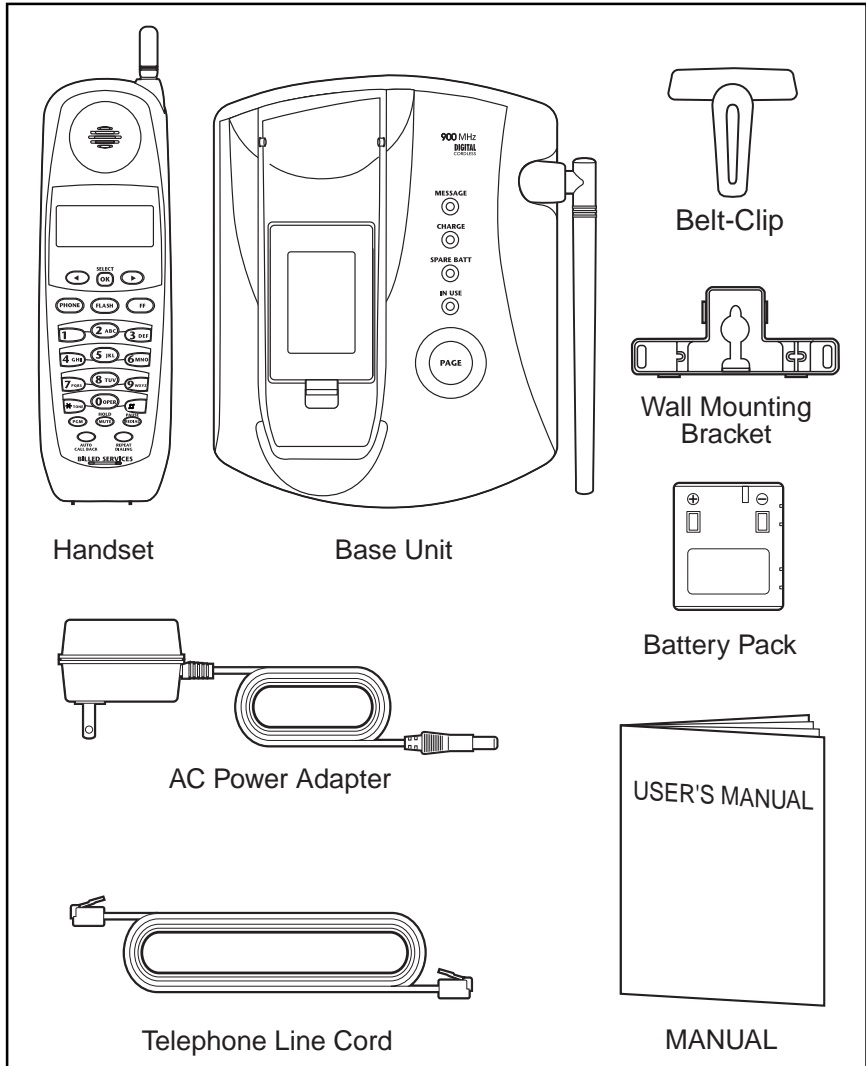

FCC AND IC REGULATIONS

This equipment complies with Parts 15 and 68 of the Federal Communications Commission (FCC) rules for the United States. It also complies with regulations RSS210 and CS-03 of Industry and Science Canada. Operation is subject to the following two conditions: (1) this device may not cause interference, and (2) this device must accept any interference, including interference that may cause undesired operation of the device.

A label is located on the underside of the Base Unit containing either the FCC registration number and Ringer Equivalence Number (REN) or the IC registration number and Load Number. You must, upon request, provide this information to your local telephone company.

This equipment is compatible with inductively coupled hearing aids.

Should you experience trouble with this telephone equipment, please contact:

VTECH COMMUNICATIONS

SERVICE DEPT. at 1-800-595-9511.
In Canada, call VTECH Electronics at 1-800-267-7377.

For repair/warranty information. The telephone company may ask you to disconnect this equipment from the line network until the problem has been corrected.

FCC Part 15

Warning: Changes or modifications to this unit not expressly approved by the party responsible for compliances could void the user's authority to operate the equipment.

The equipment has been tested and found to comply with part 15 of the FCC rules. These limits are designed to provide reasonable protection against harmful interference in a residential installation. This equipment generates, uses and can radiate radio frequency energy and, if not installed and used in accordance with the instructions, may cause harmful interference to radio communications. However, there is no guarantee that interference will not occur in a particular installation. If this equipment does cause harmful interference to radio or television reception, which can be determined by turning the equipment off and on, the user is encouraged to try and correct the interference by one or more of the following measures:

- Reorient or relocate the receiving antenna.
- Increase the separation between the equipment and receiver.
- Connect the equipment into an outlet or on a circuit different from that to which the receiver is connected.
- Consult the dealer or an experienced radio/TV technician for help.

FCC AND IC REGULATIONS

FCC Part 68

The FCC requires that you connect your cordless telephone to the nationwide telephone network through a modular telephone jack (USOC RJ11C, RJ11W or RJ14).

Your telephone company may discontinue your service if your equipment causes harm to the telephone network. They will notify you in advance of disconnection, if possible. During notification, you will be informed of your right to file a complaint with the FCC.

Occasionally, your telephone company may make changes in its facilities, equipment, operation, or procedures that could affect the operation of your equipment. If so, you will be given advance notice of the change to give you an opportunity to maintain uninterrupted service.

The Base Unit contains no user serviceable parts. The Handset contains a user replaceable battery pack.

If it is determined that your telephone equipment is malfunctioning, the FCC requires that it not be used and that it be unplugged from the modular jack until the problem has been corrected. Repairs to this telephone equipment can only be made by the manufacturer or its authorized agents or by others who may be authorized by the FCC. For repair procedures, follow the instructions outlined under the VTECH Limited Warranty.

This equipment may not be used on coin service provided by the phone company or Party Lines.

The REN is useful in determining the number of devices you may connect to your telephone line and still enable the devices to ring when you receive a call. The general rule is that the REN value should not exceed 5.0 total; however, contact your local telephone company for the specific number in your area.

FCC AND IC REGULATIONS

IC (Industry Canada)

This telephone is registered for use in Canada.

Notice: The REN assigned to this device denotes the number of devices you may connect to the telephone loop which is used by the device to prevent overloading. The termination on a loop may consist of any combination of devices subjected only to the requirement that the sum of the REN does not exceed five (5.0).

Notice: The Industry Canada label identifies certified equipment. This certification means that the equipment meets certain telecommunications network protective, operational and safety requirements. The Department does not guarantee the equipment will operate to the user's satisfaction.

Before installing this equipment, users should ensure that it is permissible to be connected to the facilities of the local telecommunications company. The equipment must also be installed using an acceptable method of connection. The customer should be aware that compliance with the above conditions may not prevent degradation of services in some situations.

Repairs to certified equipment should be made by an authorized Canadian maintenance facility designated by the supplier. Any repairs or alterations made by the user to this equipment, or equipment malfunctions, may give the telecommunications company cause to request the user to disconnect the equipment.

Users should ensure for their own protection that the electrical ground connections of the power utility, telephone lines and internal metallic water pipe system, if present, are connected together. This precaution may be particularly important in rural areas.

Caution: Users should not attempt to make such connections themselves, but should contact the appropriate electrical inspection authority, or electrician, as appropriate.

Your VT 1923 is designed to operate at the maximum power allowed by the FCC and IC. This means your Handset and Base Unit can communicate only over a certain distance - which will depend on the location of the Base Unit and Handset, weather, and the construction and layout of your home or office.

IMPORTANT SAFETY INSTRUCTIONS

When using your telephone equipment, basic safety precautions should always be followed to reduce the risk of fire, electric shock and injury to persons, including the following:

1. Read and understand all instructions.
2. Follow all warnings and instructions marked on the product.
3. Unplug this product from the wall outlet before cleaning. Do not use liquid cleaners or aerosol cleaners. Use a damp cloth for cleaning.
4. Do not use this product near water (for example, near a bath tub, wash bowl, kitchen sink, or laundry tub, in a wet basement, or near a swimming pool).
5. Do not place this product on an unstable cart, stand, or table. The product may fall, causing serious damage to the product.
6. Slots and openings in the cabinet and the back or bottom are provided for ventilation. To protect it from overheating, these openings must not be blocked by placing the product on the bed, sofa, rug, or other similar surface. This product should never be placed near or over a radiator or heat register. This product should not be placed in a built-in installation where proper ventilation is not provided.
7. This product should be operated only from the type of power source indicated on the marking label. If you are not sure of the type of power supply to your home, consult your dealer or local power company.
8. Do not allow anything to rest on the power cord. Do not locate this product where the cord will be abused by persons walking on it.
9. Never push objects of any kind into this product through cabinet slots as they may touch dangerous voltage points or short out parts that could result in a risk of fire or electric shock. Never spill liquid of any kind on the product.
10. To reduce the risk of electric shock, do not disassemble this product, but take it to a VTEch authorized service facility. Opening or removing cabinet parts other than specified access doors may expose you to dangerous voltages or other risks. Incorrect reassembling can cause electric shock when the appliance is subsequently used.
11. Do not overload wall outlets and extension cords as this can result in the risk of fire or electric shock.

IMPORTANT SAFETY INSTRUCTIONS

12. Unplug this product from the wall outlet and refer servicing to a VTech authorized service facility under the following conditions:
 - A. When the power supply cord or plug is damaged or frayed.
 - B. If liquid has been spilled into the product.
 - C. If the product has been exposed to rain or water.
 - D. If the product does not operate normally by following the operating instructions. Adjust only those controls that are covered by the operating instructions, because improper adjustment of other controls may result in damage and will often require extensive work by a VTech authorized technician to restore the product to normal operation.
 - E. If the product has been dropped and the cabinet has been damaged.
 - F. If the product exhibits a distinct change in performance.
13. Avoid using a telephone (other than a cordless type) during an electrical storm. There may be a remote risk of electric shock from lighting.
14. Do not use the telephone to report a gas leak in the vicinity of the leak.

CAUTION: TO REDUCE THE RISK OF FIRE OR INJURY TO PERSONS BY BATTERY, READ AND FOLLOW THESE INSTRUCTIONS.

1. Use only the appropriate type and size battery pack specified in the instruction manual provided for this product.
2. Do not dispose of the battery pack in a fire. The cell may explode. Check with State and local codes for possible special disposal instructions.
3. Do not open or mutilate the battery pack. Released electrolyte is corrosive and may cause damage to the eyes or skin. It may be toxic if swallowed.
4. Exercise care in handling battery in order not to short the battery with conducting materials such as rings, bracelets, and keys. The battery or conductor may overheat and cause burns.
5. Charge the battery pack provided with or identified for use with this product only in accordance with the instructions and limitations specified in the instruction manual.
6. Observe proper polarity orientation between the battery pack and battery charger.

VTECH COMMUNICATIONS

SERVICE DEPT. at 1-800-595-9511.
In Canada, call VTECH Electronics at
1-800-267-7377.

SAVE THESE INSTRUCTIONS

GETTING STARTED

AC Power Adapter

Plug the **AC power adaptor** into a live electrical outlet and the **DC POWER CONNECTOR** into the back of the Base Unit.

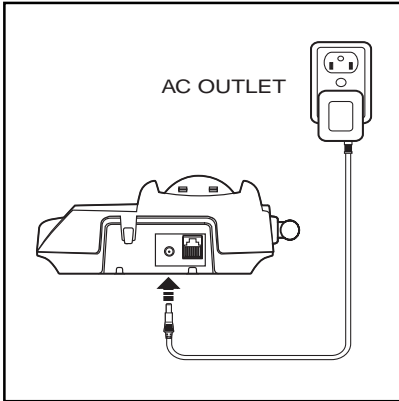

Slide the Handset battery cover down, and remove it from the Handset.

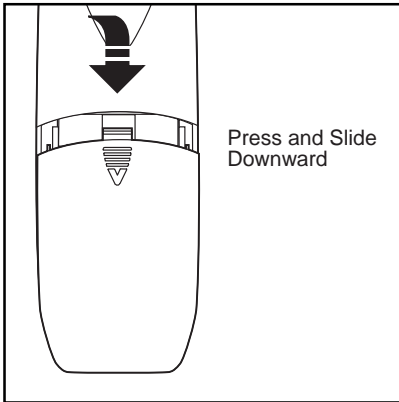

Install the BATTERY PACK, with the metal contacts facing down and aligned with the Handset contacts. Replace Handset battery cover.

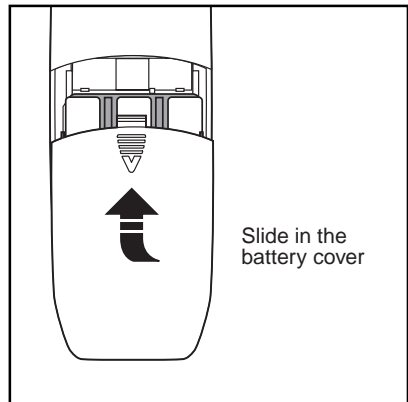
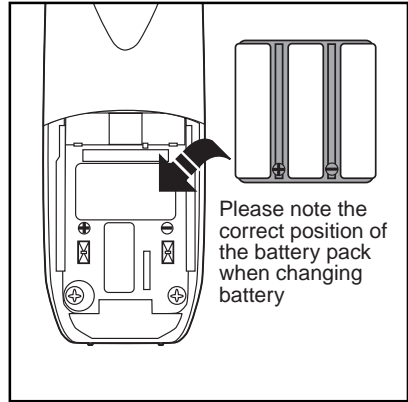

Place the Handset into the Base Unit cradle. Make sure the Charging light is illuminated. **Charge for at least 16 hours before first using the phone.** The Handset can charge face up or down.

GETTING STARTED

Setting the Tone/Pulse Switch

Set the **TONE/PULSE** switch, located on the antenna side of the Base Unit, to the desired dialing mode. In most areas, **TONE** is the desired mode.

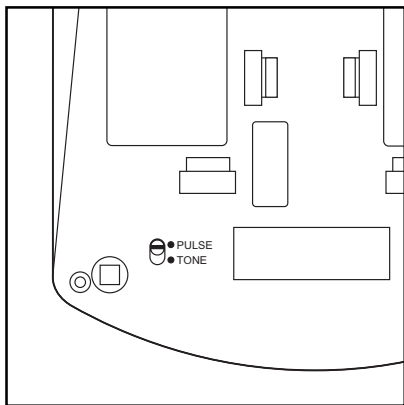

After charging the battery pack, connect the telephone line cord to a live telephone outlet and the TEL. LINE jack, located on the back edge of the Base Unit.



If your Base Unit is not connected to a live telephone outlet, the Handset will display:

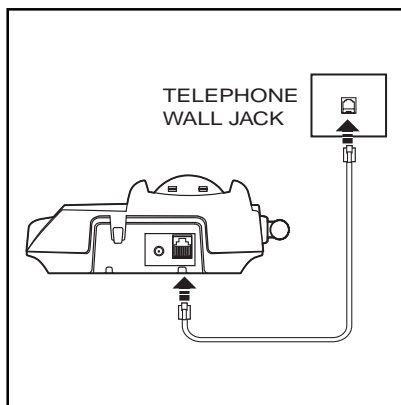

For best results, raise the antenna on the Base Unit and Handset when using the phone.

WALL MOUNTING

The Wall Mounting bracket is designed to fit on standard Wall Mounting plates.

1. **Choose a spot near an electrical outlet and a telephone jack.**

Your phone requires a modular telephone jack and a standard electrical outlet (120v AC). The power cord is six feet long; make sure there is an electrical outlet within reach of the Base Unit. The outlet should not be controlled by a wall switch. If the switch is ever turned off, the phone will not operate.

2. **Position the wall mount bracket on the base.**

Line up the tabs on the wall mounting bracket with the holes on the bottom of the base. Snap the wall mounting bracket firmly into place.

3. **Mount the base on the wall.**

Position the base so the mounting studs will fit into the holes on the bottom of the base. Position the power cord to extend down the wall. Slide the base down on the mounting studs until it locks into place.

4. **Connect the telephone line cord.**

Insert one end into the TEL.LINE jack on the back edge of the base. Insert the other end into the wall jack.

5. **Plug the AC adapter into an electrical outlet and the DC connector into the power jack located on the back of the Base Unit .**

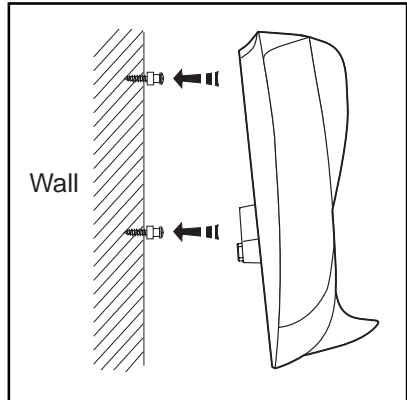
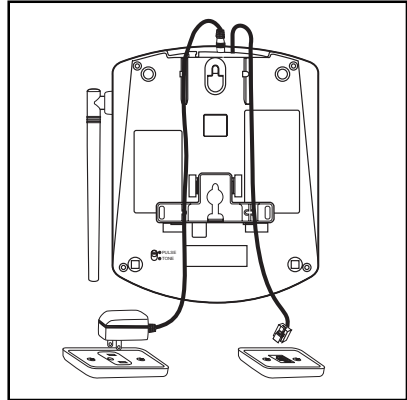

THE HANDSET LAYOUT

THE HANDSET FEATURES

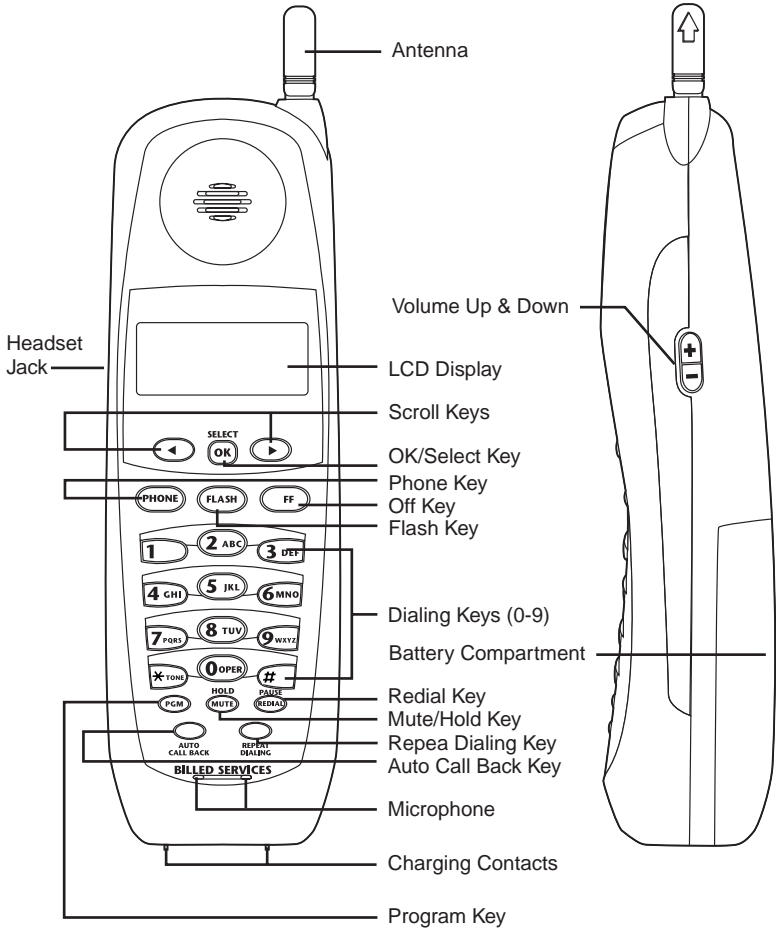

THE BASE UNIT LAYOUT

THE BASE UNIT FEATURES

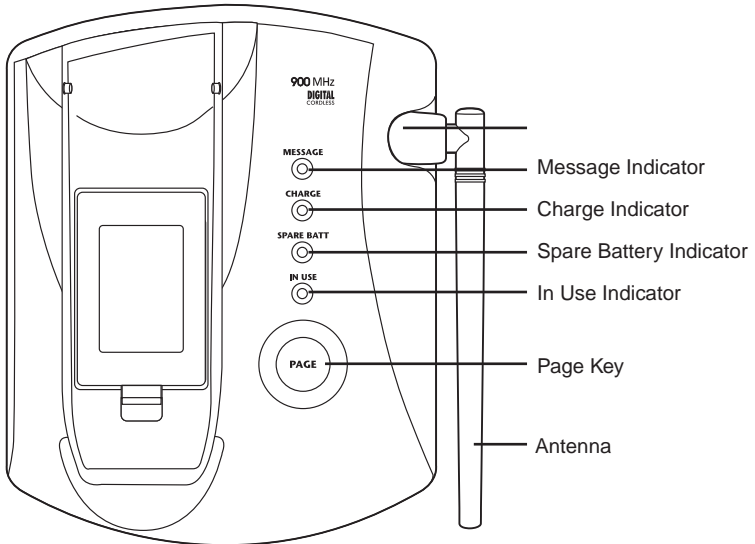
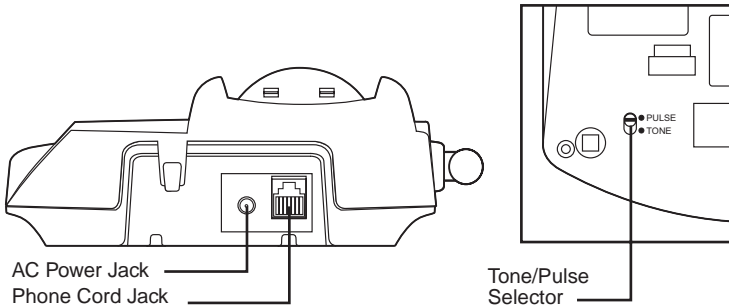

BASIC OPERATION

AREA CODE PROGRAMMING

To benefit from all the Caller ID features of your telephone, you must enter your home area code.

If you live in an area where you dial calls within your own area code by dialing 7 digits (no area code), follow these steps (with the Handset **OFF**):

- Press **PGM**.
- Press until **AREA** is blinking.



- Press **OK/SELECT**.
- **HOME** should be blinking. If not, press until it blinks.

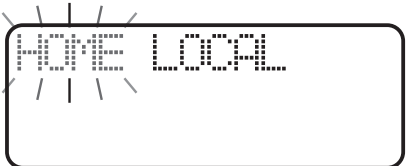

- Press **OK/SELECT**. You will see



- Enter your **own home area code**.
- Press **OK/SELECT**.

LESS COMMON ALTERNATIVE

If you live in an area where all local calls require 10 digits (area code plus phone number, without dialing "1" first:)

- Press **PGM**.
- Press until **AREA** is blinking.

- Press **OK/SELECT**.
- **HOME** should be blinking. If not, press until it blinks.
- Press **OK/SELECT**. **ENTER AREA CODE** is displayed.
- Enter **000**.
- Press **OK/SELECT** and continue below.

You may program up to 5 local area codes. An area code is "local" if you do not dial "1" when you make calls to that area code. In other words, you make calls to "local" area codes by dialing 10 digits (area code plus phone number) without a preceding "1". This might include your own area code

- Press **PGM**.
- Press ▶ until **AREA** is blinking.
- Press **OK/SELECT**.
- Press ▶ until **LOCAL** is blinking.

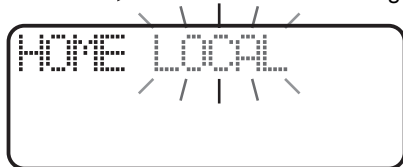

- Press **OK/SELECT**.
- Press ▶ until the desired location is blinking (**#1.....#5**).

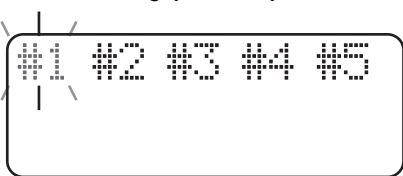

- Press **OK/SELECT**. **ENTER AREA CODE** is displayed.
- Enter a "local" area code.
- Press **OK/SELECT**.

BASIC OPERATION

MAKING CALLS

Press **PHONE**. Listen for Dial Tone. Dial the phone number. Press **OFF** to end your call.

CALL TIMER

While the Handset is **ON**, the approximate duration of your call is displayed.

REDIAL/PAUSE

- Press **PHONE**.
- Press **REDIAL**.
- The last number you called will be redialed.

ANSWERING CALLS

Press **PHONE** TALK is displayed on the Handset. Press **OFF** to end your call.

HANDSET VOLUME

Adjust the Handset volume with the and keys, located on the side of the Handset. There are 4 volume levels.

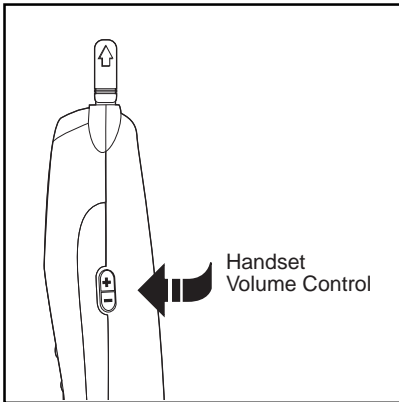

MUTE

When you mute a call, the other person cannot hear you, but you can hear them. To mute a Handset call, press **MUTE/HOLD** during the call. The Handset will display :



You can still hear the other person talk, but they cannot hear you. Press **MUTE/HOLD** again to return to normal 2-way conversation.

HOLD

To put a Handset call on hold, press and hold the **MUTE/HOLD** key for 2 seconds. The Handset will display :



Neither you nor the other person can hear each other. Press **PHONE** or Speaker to re-turn to normal 2-way conversation.

BASIC OPERATION

CALL WAITING

If you subscribe to Call Waiting, you will hear a tone when you receive a second call while on the phone. If you subscribe to Caller ID on Call Waiting, the Handset displays who is calling before you answer.

To answer Call Waiting during a normal handset call, press **PHONE**.

PAGING THE HANDSET

- To make the Handset ring, press **PAGE** on the Base.
- To stop the ringing, press **OFF** on the Handset or **PAGE** on the Base Unit.

MESSAGE INDICATOR

If you subscribe to Voice Mail, the Message light on the Base Unit will flash when you have new messages. The Handset will display:



Once you have reviewed your new messages, the **MESSAGE WAITING** indication on the Handset, and the Voice Mail light on the Base will turn off.

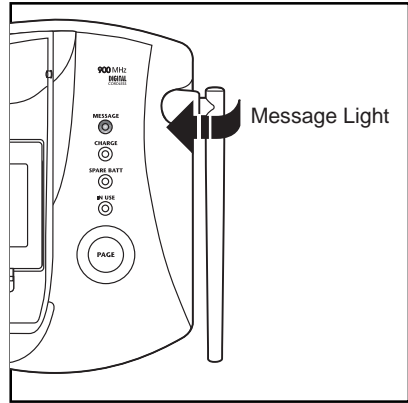

MESSAGE TIPS

After hearing your messages, wait until the Voice Mail indicators turn off before you make another call. This will ensure the indicators do not remain on after the messages are reviewed.

If, after reviewing all new voice messages, the Handset or Base Unit Message indicator remains on, using the Handset, follow these steps:

- Press **PGM**.
- Press **#**. The Handset displays:



- With **LIGHT-OFF** flashing, press **OK/SELECT**.

If you have new messages, but the Message Waiting indicators do not turn on, ask your phone company to make sure your Voice Mail service has Visual Message Indication assigned.

BASIC OPERATION

SETTING THE HANDSET RINGER

- Press **PGM** .
- Press **▶** until **RINGER** is blinking.



DIRECTORY AREA
RINGER

- Press **OK/SELECT** . **TYPE** is blinking.



RINGER TYPE VOL

- Press **OK/SELECT** .



RINGER TYPE
1 2 3 4 OFF

There are 4 ringer styles. The current setting is blinking.

- Press **◀** or **▶** to hear the other ring styles **OR** turn the Handset ringer **OFF**.
- When the desired ringer typer is blinking press **OK/SELECT** .

To turn the Handset ringer **ON** again, follow the steps in, "**Setting the Handset Ringer**".

HANDSET RINGER VOLUME

- Press **PGM** .
- Press **▶** until **RINGER** is blinking.



DIRECTORY AREA
RINGER

- Press **OK/SELECT** .
- Press **▶** until **VOL** is blinking.



RINGER TYPE VOL

- Press **◀** or **▶** to raise or lower the ringer volume.



RINGER VOLUME
))

- Press **OK/SELECT** . When you confirm the volume level.

CID-CALLER ID

This telephone provides three types of Caller ID:

CALLER ID

Displays the name and number of each caller after the phone begins ringing (requires Caller ID service from your telephone company).

CALLER ID ON CALL WAITING

Shows the name and number of each caller on Call Waiting after you hear the Call Waiting tone (requires Caller ID on Call Waiting service).

The phone has a Call Log, which stores the name, number, date, and time of the last 50 calls received. You can review the Call Log to see who called while you were out. You can speed-dial numbers from the Call Log. And you can store names and numbers from the Call Log into your directory.

Reviewing The Call Log

With the Handset OFF:

- Press ◀ or ▶ . You will see the number of NEW (not viewed) and OLD (previously viewed) calls.
- Continue to press ◀ or ▶ to review the callers. For example.



Some locations are not equipped to send Caller ID information when a person places a call. When you receive calls from such locations, your phone will display :



If a caller purposely blocks their phone number from being delivered by Caller ID, your phone will display :



HINT: If an x_ follows the phone number it indicates the party has called more than once.



The above CID record show John Smith has called 3 time to You.

ERASING CALLS

To erase a call; with the Handset OFF:

- Press ◀ or ▶ until you see the call you want to erase.
- Press **OK/SELECT** .
- Press ▶ until ERASE is blinking.



Press **OK/SELECT** .

CID-CALLER ID

- Press **▶** until **YES** is blinking. Then press **OK/SELECT**.

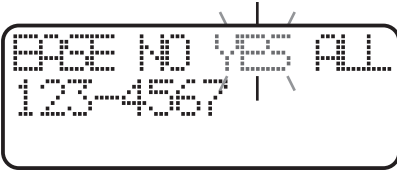

To erase your entire Call Log; after you have viewed all calls and the handset is OFF:

- Press **◀** or **▶** until you see any call in the log.
- Press **OK/SELECT**.
- Press **▶** until **ERASE** is blinking. Press **OK/SELECT**.
- Press **▶** until **ALL** is blinking. Then press **OK/SELECT**. The handset displays:



- Press **▶** until **YES** is blinking. Then press **OK/SELECT**.

SPEED DIALING FROM CALLER ID

With the Handset **OFF**:

- Press **◀** or **▶** until you see the desired caller.
- Press **PHONE**. You will hear a dial tone, and the number will be dialed automatically.
- Press **◀** or **▶** until see the desired caller.
- Press **OK/SELECT**.
- Press **OK/SELECT** when you see Dial blinking to dial out the telephone number.

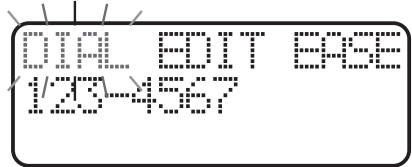

DIRECTORY

TO STORE A NAME AND NUMBER

- Press **PGM**. **DIRECTORY** will be blinking.



- Press **OK/SELECT**.
- The screen will display :



Use the Dialing keys to enter the desired name. Press the key until the desired letter or character appears. A guide to the characters:

KEY	CHARACTERS
1	1
2	A>B>C>2
3	D>E>F>3
4	G>H>I>4
5	J>K>L>5
6	M>N>O>6
7	P>Q>R>S>7
8	T>U>V>8
9	W>X>Y>Z>9
0	0
*	*
#	& ' , - . # @

If consecutive characters are found on the same key (*D* and *E*, for example), you'll need to press to advance to the next space. For example, to enter the name **DEAN**:

Press **3** (*D*)
Press
Press **3** twice (*E*)
Press **2** (*A*)
Press **6** twice (*N*)

When the name is complete, press **OK/SELECT**. The screen will display:

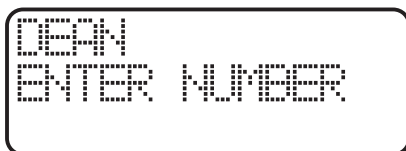

Enter the phone number. Press **REDIAL/PAUSE** if you need to enter a 2-second pause in the dialing sequence. (For example, you might store a voice mail access number, pause, password.)

When the phone number is complete, press **OK/SELECT**.

DIRECTORY

STORING A CALLER ID RECORD IN THE DIRECTORY

With the Handset **OFF**:

- Press ◀ or ▶ until you see the desired call.
- Press **OK/SELECT**.
- Press ▶ until **EDIT** is blinking.
- Press **OK/SELECT**.

If you want to edit the name, press to erase letters. Use the dialpad to enter new letters. When the name is correct, press **OK/SELECT**.

If you want to edit the number, press to erase digits. Use the dialpad to enter new digits. When the number is correct, press **OK/SELECT**.

You will then hear a long beep. The name and number have been stored in the Directory.

Making DIRECTORY Calls

- Press **OK/SELECT**. **DIRECTORY** will appear.



- Press ◀ or ▶ to scroll to the desired name; *or* search by entering the first letter of the name, and then press ◀ or ▶ if necessary.
- Press **PHONE**. You will hear a dial tone, and the number will be dialed.

EDITING A DIRECTORY ENTRY

- Press **OK/SELECT**. The Handset says **DIRECTORY**.
- Press ◀ or ▶ to scroll to the desired name; *or* search by entering the first letter of the name, and then press ◀ or ▶ if necessary.
- Press **OK/SELECT**.
- Press until **EDIT** is blinking.
- Press **OK/SELECT**. The name appears.
- If you want to edit the name, press ▶ to erase letters. Use the dialpad to enter new letter. When the name is correct, press **OK/SELECT**.

If you want to edit the number, press ▶ to erase digits. Use the dialpad to enter new digits. When the number is correct, press **OK/SELECT**.

Erasing A DIRECTORY Entry

- Press **OK/SELECT**.
- Press ◀ or ▶ to scroll to the desired name; *or*, search by entering the first letter of the name, and then press ◀ or ▶ if necessary.
- Press **OK/SELECT**.
- Press ▶ until **ERASE** is blinking.
- Press **OK/SELECT**. Press ▶ until **YES** is blinking.
- Press **OK/SELECT**.

HEADSET OPERATION

Your Vtech cordless phone is equipped with a 2.5mm Headset Jack for use with an optional accessory Headset for hands-free operation.

If you choose to use the Headset option, you must obtain an optional accessory Headset, which is compatible with the Vtech cordless phone.

To purchase a Headset, call Vtech at 1-800-595-9511.

Once you have a compatible 2.5mm Headset, locate the Headset Jack on the Vtech cordless phone Handset. Connect the plug on the Headset cord to the jack on the cordless Handset. The plug should fit securely. Do not force the connection.

OPERATION

NOTE:

Whenever a compatible Headset is connected to the cordless Handset, the microphone on the Handset will be muted. This is done to limit the effect of background noise.

The following operational characteristics apply to Vtech Headsets. The same may also apply to other, non-Vtech supplied Headsets, but Vtech assumes no responsibility for their performance.

The Vtech compatible Headset has a reversible, monaural design. You can wear your Headset on either ear, leaving one ear free for room conversation.

The headband can be adjusted to fit the contour of your head. Using both hands, slide the headband up or down

so that it rests comfortably on your head, with the speaker cushion centered against your ear.

For maximum sound quality, the flexible microphone should be positioned at the corner of your mouth, about one inch from your face.

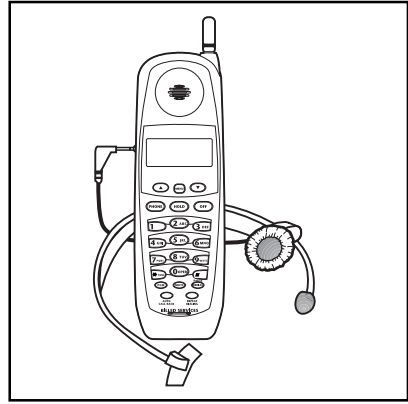

BELT CLIP

The Vtech cordless phone is also equipped with a detachable belt clip. Align the pins on the inside edge of the clip with the notches on the sides of the Vtech cordless phone Handset. The belt clip should snap securely into place. Do not force the connection.

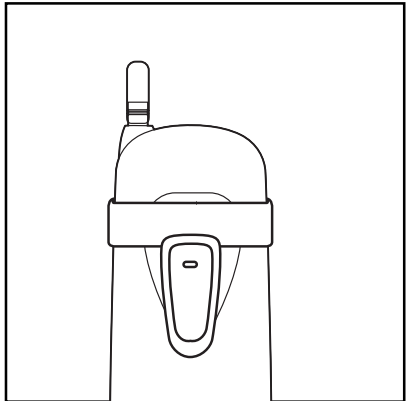

ADDITIONAL OPERATIONS

BILLED SERVICES (BLUE KEYS)

The Handset provides 3 keys that give you easy access to convenient custom features:

- * 69 Auto Callback
3-Way Calling

NOTE:

You can subscribe to any of these services for a monthly fee. If you do not subscribe, a fee is charged to your phone bill when you use the services. For specific information about rates, contact your local telephone company.

*69 AUTO CALLBACK

This key will dial the last person who called you, whether you answered the call or not. (This is most useful if you do not subscribe to Caller ID.)

Repeat Dialing

This key will repeatedly dial the last number you called. For example, if you dial a number that's busy, press **OFF**, then **Repeat Dialing**, then **OFF** again. For up to 30 minutes, your line will keep trying to reach the number. When it gets through, your phone will ring to let you know. Press **PHONE** and wait for the other person to answer.

3-WAY CALLING

This key allows you to talk to 2 people at 2 different locations at the same time. While you have one person on the line:

- Press **3-Way Calling** and listen for dial tone. •Dial the phone number of the second person.
- After the second person has answered, press **3-Way Calling**.

You are now connected with both people. Press **3-Way Calling** again to drop the last person. Press **OFF** to end your call.

MAINTENANCE

Taking Care Of Your Telephone

Your VT 1923 cordless telephone contains sophisticated electronic parts, so it must be treated with care.

Avoid rough treatment

Place the Handset down gently. Save the original packing materials to protect your telephone if you ever need to ship it.

Avoid water

Your telephone can be damaged if it gets wet. Do not use the Handset outdoors in the rain, or handle it with wet hands. Do not install your Base Unit near a sink, bathtub or shower.

Electrical storms

Electrical storms can sometimes cause power surges harmful to electronic equipment.

For your own safety, use caution when using electric appliances during storms.

Cleaning your telephone

Your telephone has a durable plastic casing that should retain its luster for many years. Clean it only with a soft cloth slightly dampened with water or a mild soap. Do not use excess water or cleaning solvents of any kind.

Remember that electrical appliances can cause serious injury if used when you are wet or standing in water. If your Base Unit should fall into water, **DO NOT RETRIEVE IT UNTIL YOU UNPLUG THE POWER CORD AND TELEPHONE LINE CORDS FROM THE WALL.** Then pull the unit out by the unplugged cords.

IN CASE OF DIFFICULTY

If you have difficulty operating your phone, the suggestions below should solve the problem. If you still have difficulty after trying these suggestions, call VTECH Communications at 1-800-595-9511. In Canada, call VTECH Electronics at 1-800-267-7377.

The Phone Doesn't Work At All

- Make sure the Power Cord is plugged
- Make sure the telephone line cord is plugged firmly into the Base Unit and the telephone wall jack.
- Make sure the batteries are properly charged. If the 'LOW BATTERY' message is shown, the battery pack needs charging.

No Dial Tone

- First check all the suggestions above.
- If you still don't hear a dial tone, disconnect the Base Unit from the telephone jack and connect a different phone. If there is no dial tone on that phone either, the problem is in your wiring or local service. Call your local telephone company.

You Get Noise, Static, Or A Weak Signal Even When You're Near The Base Unit

- Household appliances plugged into the same circuit as the Base Unit can sometimes cause interference. Try moving the appliance or the Base Unit to another outlet.

You Get Noise, Static, Or A Weak Signal When You're Away From The Base Unit

- You may be out of range. Either move close to the Base, or relocate the Base Unit.
- The layout of your home may be limiting the range. Try moving the Base Unit to another position.

The Handset Does Not Ring When You Receive A Call

- Make sure you have the Handset ringer activated. To set the ringer, see "**PROGRAMMING THE RINGER**".
- Make sure the telephone line cord is plugged firmly into the Base Unit and the telephone jack. Make sure the power cord is plugged in.
- You may be too far from the Base Unit.
- You may have too many extension phones on your telephone line to allow all of them to ring. Try unplugging some of the other phones.

You Hear Other Calls While Using Your Phone

- Disconnect your Base Unit from the telephone jack, and plug in a regular telephone. If you still hear other calls, the problem is probably in your wiring or local service. Call your local telephone company.

You Hear Noise In The Handset, And None Of The Keys Or Buttons Work

- Make sure the power cord is plugged in.

Common Cure For Electronic Equipment

Electronics, like people, can sometimes get confused. If the unit does not seem to be responding normally, then try putting the Handset in the cradle. If it does not seem to respond after trying this a few times, do the following (in the order listed):

1. Disconnect the power to the Base.
2. Disconnect (remove) the Handset battery pack.
3. Remove the base unit battery pack where applicable.
4. Wait a few minutes.
5. Connect power to the Base.
6. Install the handset battery pack.
7. Install the base unit battery pack where applicable.
8. Place the handset in the base unit cradle. If the handset has not been recently charged, allow 8 hours before use.

WARRANTY STATEMENT

WHAT DOES OUR WARRANTY COVER?

- Any defect in material or workmanship.

FOR HOW LONG AFTER THE ORIGINAL PURCHASE?

- To the original purchaser only - ONE YEAR.

WHAT WILL VTECH DO?

- At our option, repair or replace your unit.

HOW DO I SEND MY UNIT, IN OR OUT OF WARRANTY?

- In the U.S. Call VTECH Communications customer service for Return Authorization at:
1-800-595-9511. In Canada, call 1-800-267-7377
- Properly pack your unit. Include any cables & accessories which were originally provided with the product. We recommend using the original carton and packing materials.
- Include in the package a copy of the sales receipt or other evidence of date of original purchase (if the unit was purchased within the last twelve months).
- Print your name and address, along with a description of the defect, and include this in the package.
- Include payment for any service or repair not covered by warranty, as determined by VTECH Communications.
- Ship the unit via UPS Insured, or equivalent to:
- In the U.S.

VTECH COMMUNICATIONS
11035 SW 11th STREET
BDLG. B, SUITE 270
BEAVERTON, OREGON 97005

If you purchased your phone in Canada, Ship the unit via UPS Insured, or equivalent to:

VTECH ELECTRONICS
SUITE 200-7671 ALDERBRIDGE WAY
RICHMOND, B.C. V6X 1Z9

VTECH Communications assumes no responsibility for units sent without prior Return Authorization.

WARRANTY STATEMENT

WHAT DOES OUR WARRANTY NOT COVER?

- Batteries
- Damage from misuse, neglect, or acts of nature (lightning, floods, power surges, etc.)
- Products which may have been modified or incorporated into other products
- Products purchased and/or operated outside the USA, its territories, or Canada.
- Products serviced by the owner or a service facility not expressly authorized by VTECH Communications
- Products purchased more than 12 months from current date
- Units purchased in "AS IS" condition, or units purchased as "Distressed Merchandise".

HOW DOES STATE LAW OR PROVINCIAL LAW RELATE TO THIS WARRANTY?

- This warranty gives you specific rights. You may also have other rights which vary from state to state as province to province.

TECHNICAL SPECIFICATIONS

FREQUENCY CONTROL

Crystal Controlled Dual PLL
Synthesizer

TRANSMIT FREQUENCY

Handset : 923.10 MHz to 927.75 MHz
(All 30 channels within this
range)

Base : 902.3 MHz to 906.65 MHz
(All 30
channels within this range)

RECEIVE FREQUENCY

Handset : 902.3 MHz to 906.65 MHz
(All 30 channels within this
range)

Base : 923.10 MHz to 927.75MHz
(All 30 channels within this
range)

NOMINAL EFFECTIVE RANGE

Maximum power allowed by FCC and
IC. Actual operating range may vary
according to environmental conditions
at the time of use.

SIZE

Handset :18 x 5.7 x 4.1cm (L x W xT)
Maximum (Antenna
excluded)

Base : 20.5 x 17 x 70cm (L x W x
T) Maximum (Antenna
excluded)

WEIGHT

Handset : 150 grams
Base : 295 grams

POWER REQUIREMENTS

Handset : Self-contained nickel-
cadmium rechargeable
battery supply, 3.6V
nominal, 600mAh capacity.

Base : 9VDC @ 300mA

MEMORY

Speed Dial: 50 Memory locations, 16
digits per location.

CID : Alpha Numeric Display
50 Memory locations

SPECIFICATIONS ARE TYPICAL AND MAY CHANGE WITHOUT NOTICE.



VTECH COMMUNICATIONS LTD.



Is a trademark of VTECH COMMUNICATIONS LTD., a member
of THE VTECH GROUP OF COMPANIES.

Distributed in the U.S.A. by VTECH Communications, 8770 SW Nimbus Avenue / Beaverton.
Oregon, 97008

Distributed in the Canada by Vtech Electronics Canada Ltd., Suite 200-7671 Alderbridge
Way Richmond, B.C. V6X 1Z9.

Copyright 1999 for VTECH COMMUNICATIONS LTD..
Printed in China

91-xxxx-xx-00
ISSUE 0