

Snowblowers

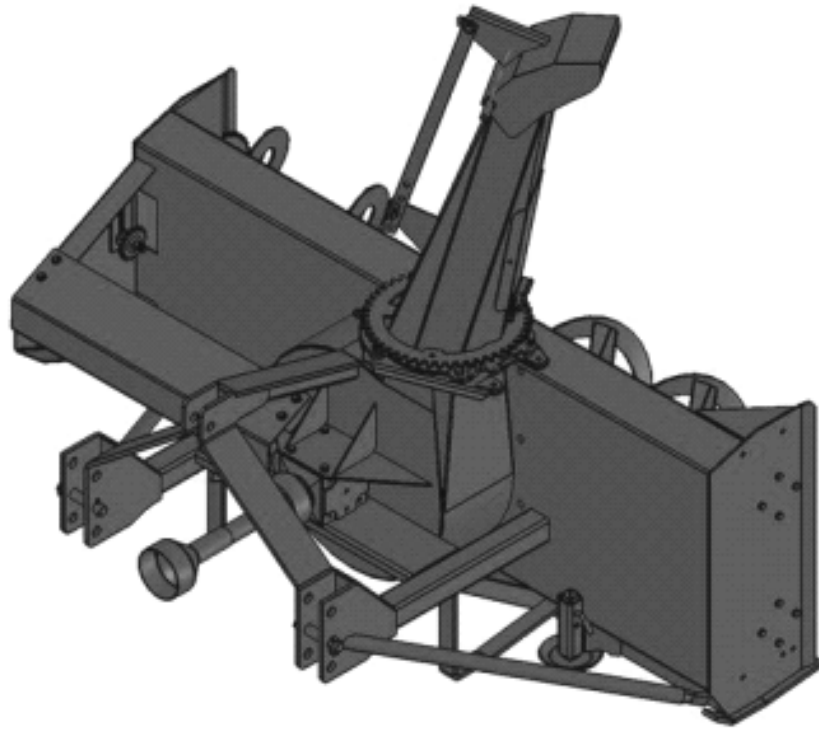

Owners Manual
Parts List for 87D (87" Double Auger) Snowblower



M K Martin Enterprise

3950 Steffler Rd Elmira Ont N3B 2Z3
(519) tel 664-2752 / fax 664-3695
E-mail: sales@mkmartin.ca

87D Meteor Snowblower Table of Contents

1. Registration and Warranty
2. Safety Introduction
3. Safety
4. Decal Location
5. Sign Off Form
6. Assembly Information
7. Operation
8. Installing manual Chute Rotator
9. Installing Hydraulic Chute Rotator
10. Main Parts
11. Chute Rotator Parts
12. Gearbox Parts
13. Comer PTO Parts
14. Canimex PTO Instructions
15. Bolt Torque
16. Maintenance – Lubrication - Storage – Notes

Welcome to our lineup of Meteor Snowblowers

M K Martin Enterprise Inc has been building the Meteor Snowblowers since 1985. With proper care and maintenance the Meteor Snowblower will give you years of reliable service. The most common damage to a Snowblower is from foreign objects. Please ensure that the area to be cleared of snow has been cleared of articles before the first snow falls. This gives you peace of mind and the assurance that you won't get damaging objects into your blower. Please read this manual to become familiar with the Meteor Snowblower and the safe operation of the Meteor Snowblower.

Warranty and Limitation Of Liability

All equipment is sold subject to mutual agreement that it is warranted by M K Martin Enterprise Inc. (hereafter called the company) to be free of any defects of material and workmanship. But the company shall not be liable for special, indirect or consequential, damages of any kind under this contract or otherwise. The company's liability shall be limited exclusively to replacing or repairing without charge, at it's factory or elsewhere, at it's discretion, any material, or workmanship defects, which becomes apparent within one year from the date of purchase. The company will have no liability for damages of any kind. The buyer by the acceptance of the equipment will assume all liability for any damages, which may result from the use or misuse by his employees or others.

Warranty coverage is null and void unless the Warranty Registration form has been completely filled in and is on file at

M K Martin Enterprise Inc
3950 Steffler Road
Elmira Ont. Ca.
N3B 2Z3

For your record

Purchase Date Y20 M

Model # _____

Serial # _____

Please cut at dotted line and return this registration form to the company via Mail, Fax (519-664-3695) or e-mail-- sales@mkmartin.ca

M K Martin Inc
3950 Steffler Road
Elmira Ont. Ca.
N3B 2Z3

Meteor

Buyers

Purchase Date Y20 M

Model # _____

Serial # _____

Name _____

Address _____

Postal Code _____

Safety

Take Note! This safety symbol is found throughout this manual to call your attention to instructions involving yourself and others working around the machine.

- **Failure to follow these instructions can result in injury or death!**



This symbol means

**--Attention!
--Become Alert!
--Your Safety is involved!**

Signal words are used in this book.

Caution: Indicates a potentially hazardous situation that may result injury.

Warning: Indicates a potentially hazardous situation that could result in serious injury or death.

Danger: Indicates a hazardous situation that needs to be avoided. It is you the operator that needs to be aware of these dangers.

If you have any questions not answered in this manual, please contact your dealer or M K Martin Enterprise Inc.

3950 Steffler Rd

Elmira On Ca

N3B 2Z3

Tel; 519-664-2752

Fax; 519-664-3695

e-mail; sales@mkmartin.ca



Safety – It's in your interest.



Safety Guidelines.

Safety of the operator is one of our main concerns, however it is up to the operator to practice caution.

To avoid personal injury, study the following precautions and insist that those working with you to follow them.

The Meteor Snowblower has only 2 shields, one shield is the PTO drive shield and the other is a shield for the power hood turner if used. **Do not** use the blower with the auger drive cover removed, as this is part of the blower frame.

Replace any decals that may be missing or not readable. Location of decals are indicated elsewhere in this manual.

Do not use this machine while under the influence of drugs or alcohol.

Review the safety instructions with all users annually.

This equipment should not be operated by children: or those unfamiliar with the operation of the Meteor® Blower. **Do not allow persons to operate this machine until they have read this manual and/or were instructed by a qualified person.**

Do not paint over, remove or deface any safety signs or warning decals on the Meteor® Blower. **Observe all safety signs and practice the instructions on them.**

Do not use this machine to push snow as this can result in the augers to be broken or bent.



Please be careful with the extra weight on the back of the tractor. It may be necessary to add weights on the front of the tractor to keep it balanced properly.



When changing shearpins or removing ice or snow from the machine **Please stop the engine and remove the key on the tractor!** This will reduce the possibility of the blower to be started and cause personal injury.

75-108 Meteor Snowblower Assembly Information

1. 2 set Hood Bearing Assembly
2. 4 pc 5/8 Wavewasher (*thin*)
3. 2 pc 5/8 x 2 UNF Bolts
4. 2 pc 5/8 UNF Locknut
5. 1 pc 2 hole Chute Clamp
6. 1 Assembly Instructions

Upon Receiving the Meteor Snowblower

The blowers are shipped in a packaged state

These blowers are packaged without hood turner device.

Carefully remove the chute and PTO shaft from the area of the auger and set them aside. Locate the bag or package of small components.

Remove the ties that hold the Plastic ring on the blower and place the base of the chute on top of the plastic ring. (Note: Plastic Ring can be lightly coated with grease at this time.)

Take two 5/8 bolts and drop them down through the chute clamp, turn the clamp upside down while holding the bolts in the holes. place a 5/8 wave washer on the bolts, then a 5/8 bearing and finish off with a second 5/8 wave washer. Turn the clamp right side up with the washers bearings on the bolts. Carefully insert the bolts into the mounting holes and secure with locknuts.

Install the PTO with the shear bolt yoke at the gearbox. *This will provide more space to change the shear bolt.*

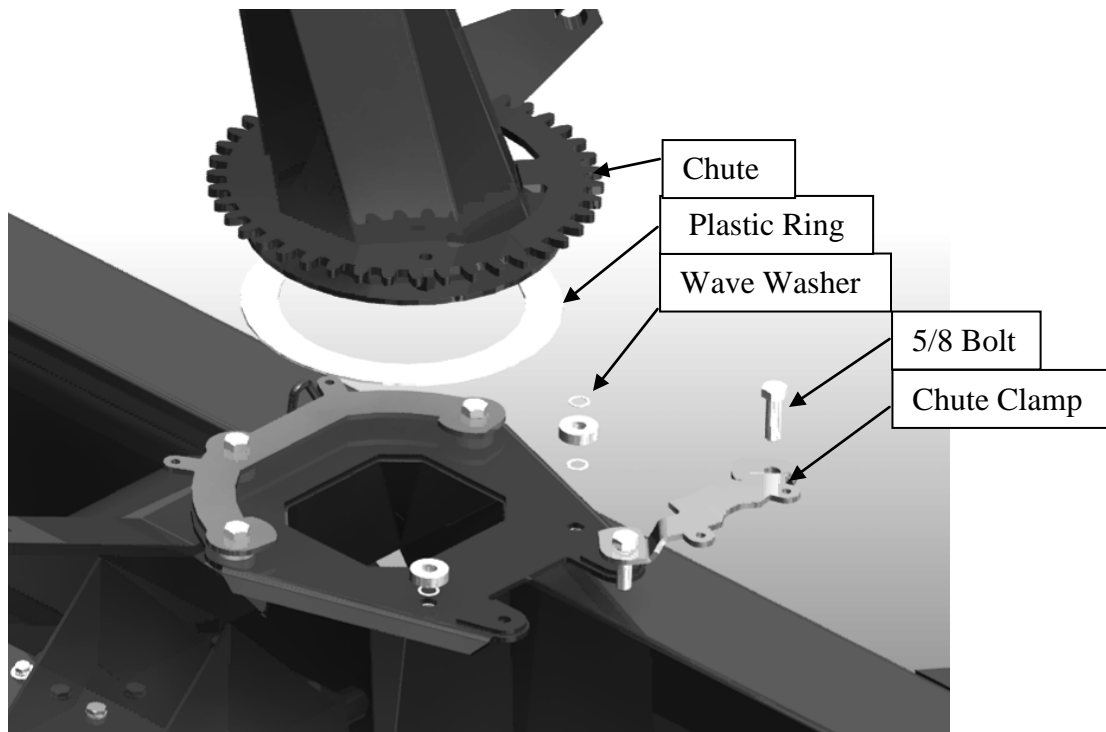

75-108 Installing the Hand Crank

The Crank package consists of

- Tail Bracket --- (1)
- Upper Bracket- (2)
- Worm Gear ---- (3)
- Crank ----- (4)
- Spring Pin ----- (5)
- Set Screws ----- (6)
- Bolts ----- (7)

Bolts	
2 pc	3/8x1
2pc	3/8 Lockwasher
2pc	5/8 x 2 1/4 UNF Bolt to replace 5/8 x 2

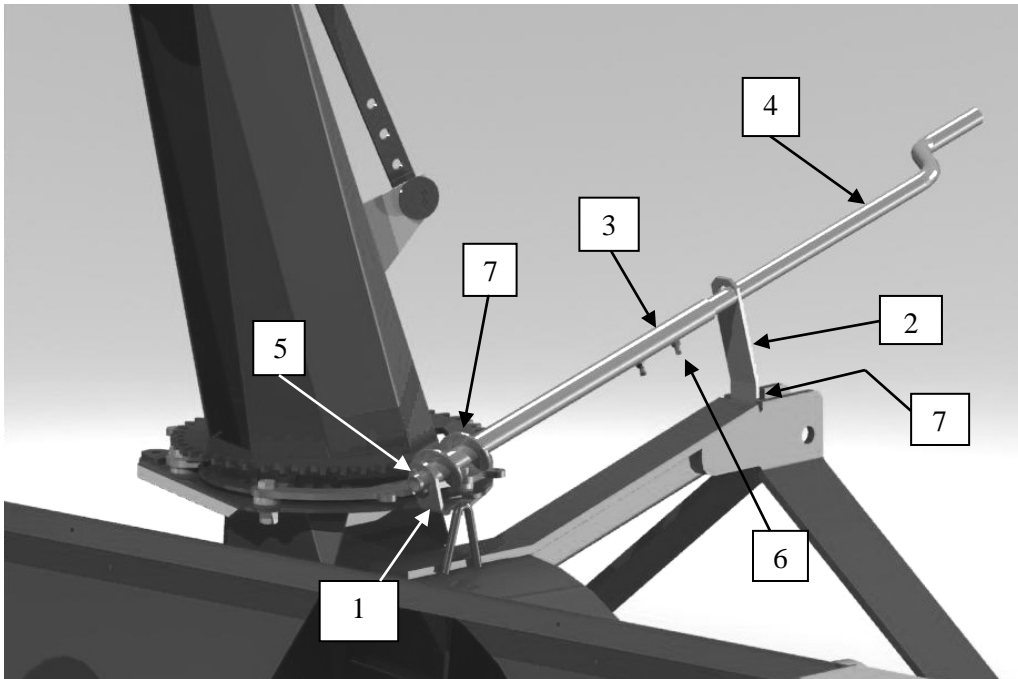

First remove the 2 nuts and bolts (as indicated), and insert the Crank Tail bracket[1] and reinstall with 5/8 x 2 1/4 bolts (supplied) and Locknuts.

Insert the bottom end of the worm gear [3] into the Tail Bracket, slide the top bracket [2] into place and secure with bolts [7]. Install spring pin [5]

Slide Crank [4] into tube as shown and secure with the Set Screws [6],



Please note! When the blower is raised, the Crank will be closer to the tractor and could damage the cab or cause injury to the operator!

Hydraulic Rotator (Accessory)

The hydraulic chute rotator uses a hydraulic motor, controlled by the tractor hydraulics to rotate the chute. The kit includes a safety shield that also keeps the snow and ice from building up on top of the gears.

The motor kit is bolted to the base with 2, 1/2-20 UNF bolts. The shield is mounted with 4, 5/16 bolts as shown.

When installing the hydraulic elbows, turn them in "**not more than 4 rounds**" then tighten the jamnut to secure the elbow in the direction that you want the hoses to go, *as shown*.

The relief valve is factory preset to 900 PSI.

Route the hoses and tie them to the top "A" frame support, away from moving equipment. Ensure that the hoses do not get too tight or rub on the frame when the blower is raised or lowered.

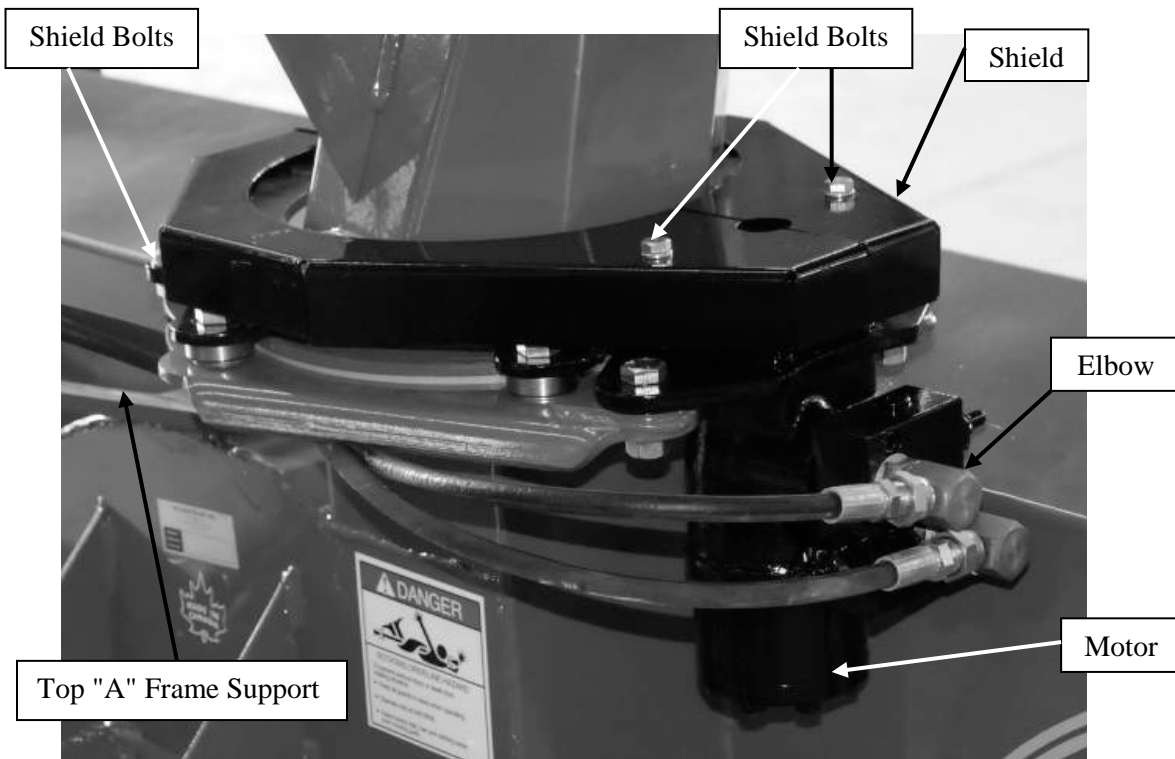

87D Meteor® Snowblower

This Blower is ideal for tractors 60 HP Cat #2 3PH.

Attaching the Meteor® Blower for the first time.

Set the blower on a level surface and back the tractor up to it. Place the lower 3PH arms of the tractor between the lower hitch plates on the blower and insert the hitch pins that came with the blower, secure these with the Lynch Pins. Next swing the top link into place and adjust the length so the top link pin can be inserted. You will have to supply the top link pin. With the top link set at this length the blower will be flat or parallel to the ground.

Do not fasten the PTO shaft to the tractor.

1. Slowly lift the blower until the gearbox shaft is at the same height as the PTO output on the tractor.
2. Push (or collapse the telescopic part of the PTO completely). If you cannot collapse it far enough to slide get it on the tractor then it has to be shortened.
3. Measure the amount that the shaft is too long. Remove it from the blower and pull it apart.
4. Take a hacksaw and cut ½ of the measurement from each end, cut both the plastic tube and the metal core.
5. Use a file to remove the burrs from the cut parts, wipe any filings from the surfaces and slide the shaft together to be sure that it slides freely.
6. Make sure the plastic shield is free to rotate on the shaft before installing on the machine.
7. Reinstall the PTO on the blower and fasten it to the tractor pushing the spring-loaded pin in and sliding the yoke onto the tractor spline until the pin snaps into place.
8. Next lift the 3PH arms to the highest point, determine the overlap on the PTO shaft. It should be at least 3” if it is too short then the PTO will jam rather than collapse. This will put severe strain on the shaft and gearbox.



9. It may come apart and this will allow a spinning PTO to become an uncontrolled weapon and could severely injure or kill someone!
10. After it has been determined that the PTO is OK and will not jam or come apart, make sure any bystanders are well away from the machine.
11. Lower the blower to ground level, engage the PTO and slowly start the blower. Make sure that everything is turning freely.
12. Slowly increase the speed until you have reached 540 RPM on the PTO. This is the speed that this blower was designed for. If it turns faster the fan could be going dangerously fast. If it turns slower it will not perform very well as the snow will not get blown very far.

Snowblower performance will vary greatly due to ambient temperature and type of snow.

Operating the Meteor® Snowblower

This blower is on the back of the tractor facing toward the rear. While blowing snow the tractor has to be backed into the snow.



Stay in the seat of the tractor all the time that the blower is running.



Make sure the area is clear of people while blowing snow.



Do not direct discharged snow toward people, cars or buildings as stones or bits of ice can go a long distance.

When you get to the place that you want clear snow, lower the blower to the ground and turn the chute to discharge the snow in the direction you want the snow to go. Engage the PTO and slowly bring the blower up to operating speed. After the blower is running use reverse gear and start backing up. The chute can be rotated from the tractor seat while blowing snow.

If your drive is paved then you may need to lengthen the top 3PH link to tilt the blower ahead so it will scrape the hard surface better.

If your drive is gravel then you may want to shorten the top 3PH link to tilt the blower back so it will not dig into the loose gravel. In colder climates where the bare ground is frozen during most of the winter the blower can be adjusted to scrape the snow off the frozen drive after freeze-up.

In areas where the gravel is not frozen most of the time we have skid shoes available to bolt on the end plates to raise the blower a few inches above the gravel.



This blower is designed to blow snow, but will blow loose gravel if care is not taken.



After the job is finished: **Disengage the PTO to stop the blower** before driving away or getting off the tractor.

The auger is protected with a safety shear bolt that will shear off if the auger becomes jammed.

The fan is also protected with a shear bolt in the PTO shaft universal joint if the fan becomes jammed.



When replacing the shear bolts STOP the engine before attempting to replace them!

There is a hydraulic hood turner available that couples into the tractor hydraulic remotes if your tractor is so equipped. This will allow you to rotate the hood without reaching back to the blower especially if you have a cab on your tractor.

87D Meteor Parts

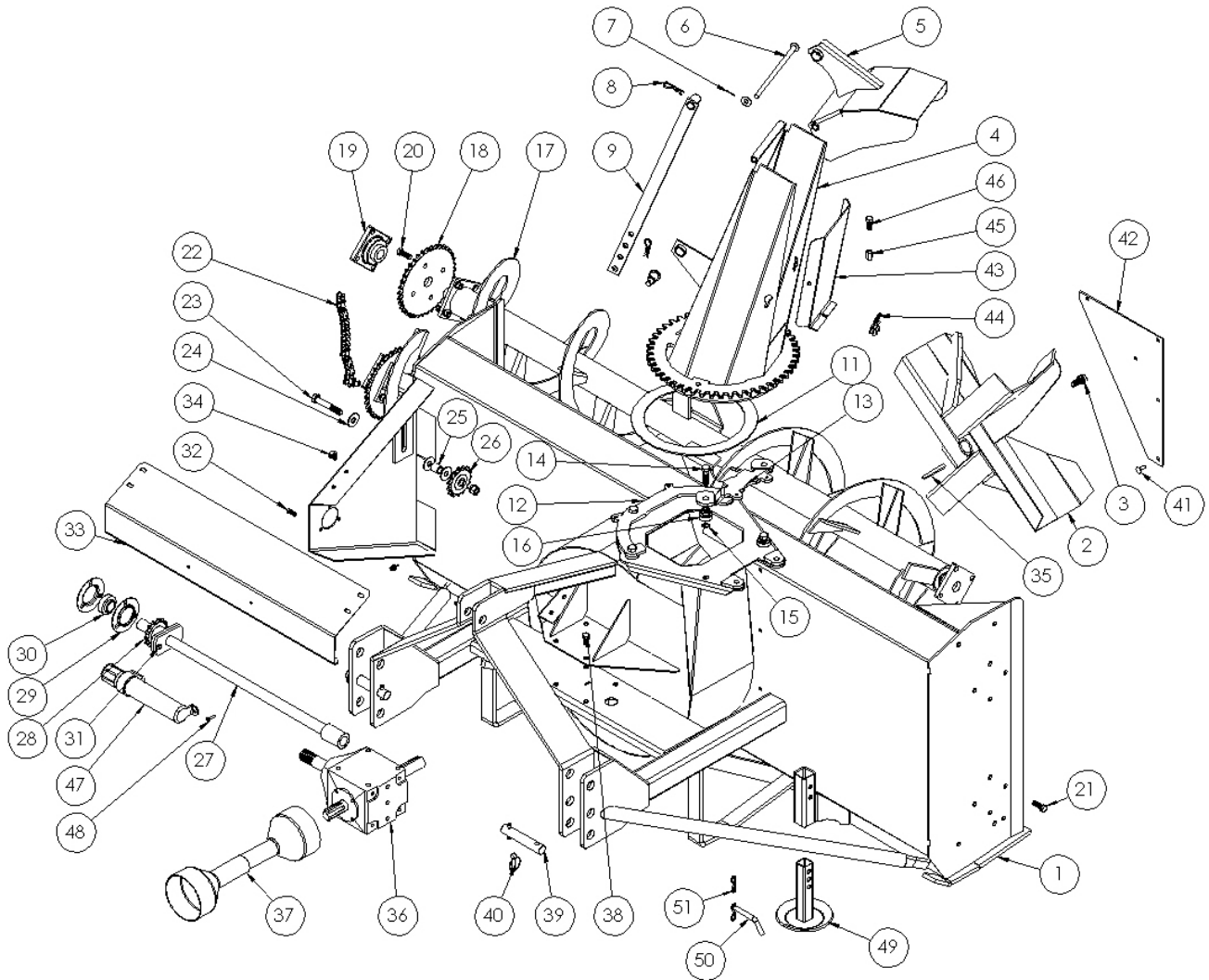

87D Meteor Snowblower			
Item No	Description	Part No	Req
1	Main Body	519-8711505D	1
2	Fan	519-87115208	1
3	Hexbolt 5/8x1 1/2 #2 c/w lw	OL	1
4	Chute	519-87116009	1
5	Deflector	519-87115608	1
6	Hinge Pin	519-87115808	1
7	Cotter Pin 1/8x1	OL	1
8	Hair Pin 5/32	OL	2
9	Adjuster	519-871155	1
10	Adjuster Pin	519-871154	1
11	Antifriction Ring	519-871161	1

87D Meteor Snowblower			
Item No	Description	Part No	Req
12	3 Hole Chute Clamp	519-87116209	1
13	2 Hole Chute Clamp	519-87116309	1
14	Hexbolt 1/2x2 unf c/w ln	OL	5
15	5/8 Wave Washer	519-871702	10
16	5/8 Bearing	519-870711	5
17	Auger	519-871164D	2
18	Auger Sprocket	519-871165	2
19	Complete Bearing	519-871169	4
	Bearing Insert Only	519-871170	4
	Cast Flange Only	519-871171	4
20	Hexbolt 1/2x1 1/2 c/w n, lw	OL	8
21	Hexbolt 1/2x1 1/2 c/w n, lw	OL	16
22	Auger Drive Chain	519-871026D	1
23	Hexbolt 5/8x4 c/w n, lw	OL	1
24	Flatwasher 3/4"	OL	3
25	Spacer	519-871028	1
26	Idler Sprocket	519-872029	1
27	Cross Shaft	519-871184	1
28	Auger Shear Sprocket	519-873025	1
29	Flangette	519-871174	2
30	Bearing	519-871175	1
31	5/16x1 1/4 c/w ln	OL	1
32	Hexbolt 3/8x1 c/w n,lw	OL	3
33	Cross Shaft Shield	519-871055D	1
34	Hexbolt 3/8x1 c/w n, lw	OL	4
35	Fan Key 3/8 sq x 3 5/8	519-871062	1
36	Gearbox	519-871186	1
37	PTO Assembly	519-871187	1
38	Hexbolt 1/2x1 c/w lw	OL	8
39	Hitch Pin	519-8720965	2
40	Lynch Pin	OL	2
41	3/8x1 Carriage bolt c/w ln, lw	OL	5
42	Fan Plate	519-20906	1
43	Chute Front	519-20883	1
44	Rubber Latch	519-099-460	1
	Pin	519-099-012	1
	Cotter Pin 1/16x1/2	OL	1
45	Chute Stop Nut	519-5117009	1
46	Hexbolt 1/2x1 1/2 c/w lw	OL	1
47	OP Manual Tube	DJA70111	1
48	RH 1/4x1 screw c/w ln	OL	2
49	Option Skid Shoe	519-21539	2
50	1/2" Bent Pin	OL	2
51	1/8" Hair Pin	OL	2

**87-97 Meteor Chute Rotator
Manual Chute Rotator**

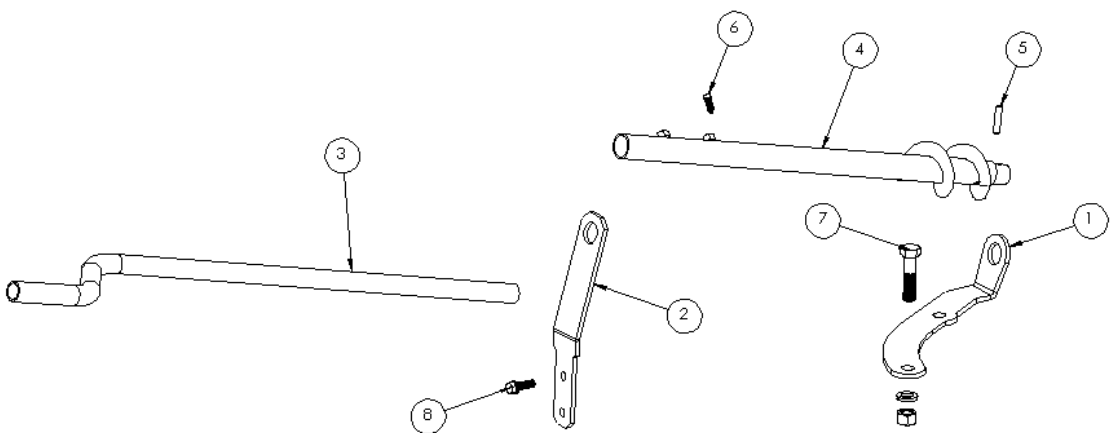

2010	Manual Rotator		
Item No	Description	Part No	Req
1	Crank Tail Bracket	519-87719109	1
2	Upper Hand Crank Bracket	519-87109009	1
3	Crank	519-68109109	
4	Crank Worm	519-68719209	1
5	5/16x1 1/2 Spring Pin	OL	1
6	5/16x3/4 sq h Setscrew	OL	2
7	5/8-11x2 1/2 Bolt c/w ln	OL	2
8	3/8x1 1/4 Bolt c/w n, lw	OL	2

Hydraulic Chute Rotator

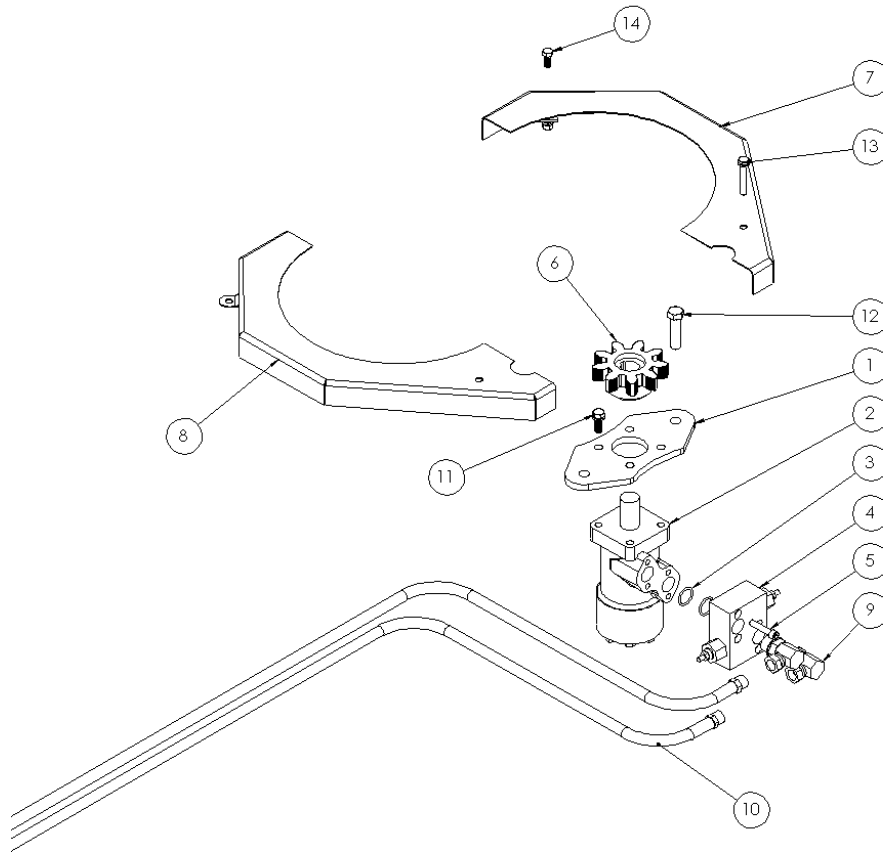

2010	Hydraulic Rotator		
Item No	Description	Part No	Req
1	Motor Bracket	519-511703	1
2	Motor	519-511704	1
3	O Ring 3/32x.755id	OL	2
4	Crossover Relief Valve	519-511705	1
5	Socket Head Cap Screw 5/16x1 1/2	OL	4
6	Small Gear	519-511706	1
7	Right Shield	519-87170709	1
8	Left Shield	519-87170809	1
9	Elbow	519-9515-10-6	2
10	Hose	519-871709	2
11	Hexbolt 3/8x1 c/w lw	OL	4
12	Hexbolt 1/2-20x2 UNF c/w n, lw	OL	2
13	Hexbolt 5/16x1 1/2 c/w lw	OL	2
14	Hexbolt 5/16x1 c/w n, lw	Ol	2

**75 – 87 – 87D - 97 Meteor Snowblower
Main Gearbox**

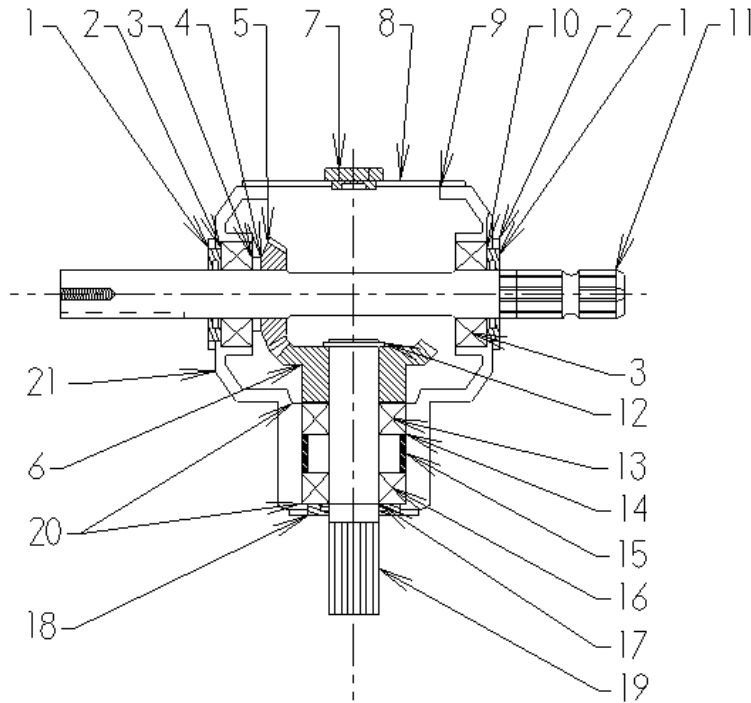

T 27D Gearbox			
Item	Description	Part #	Req
1	Double Lip Seal 40x80x12	519-87100748	2
2	Snap Ring	519-85200030	2
3	Bearing 30208	519-80900024	2
4	Shim 515	519-02447500	1
5	Gear Z18 M6.15	519-01325002	1
6	Gear Z18 M6.15	519-02675000	1
7	Plug	519-86500006	2
8	Cover	519-02671300	1
9	Bolt M10 x 14	519-81101031	4
10	Shim 79.7	519-01107500	1
11	Shaft (Thru)	519-02674221	1
12	Snap Ring 40 UN17435	519-85100029	1
13	Bearing 30207	519-80900026	1
14	Snap Ring 72 17437	519-85200131	1
15	Spacer	519-02677100	1
16	Bearing 6207	519-80100025	1
17	Snap Ring UN17435	519-85100005	1
18	Double Lip Seal 35x72x10	519-87100152	1
19	Shaft	519-02672000	1
20	Shim 48.0	519-02597500	2
21	Casing	519-02670301	1

Comer T50 PTO

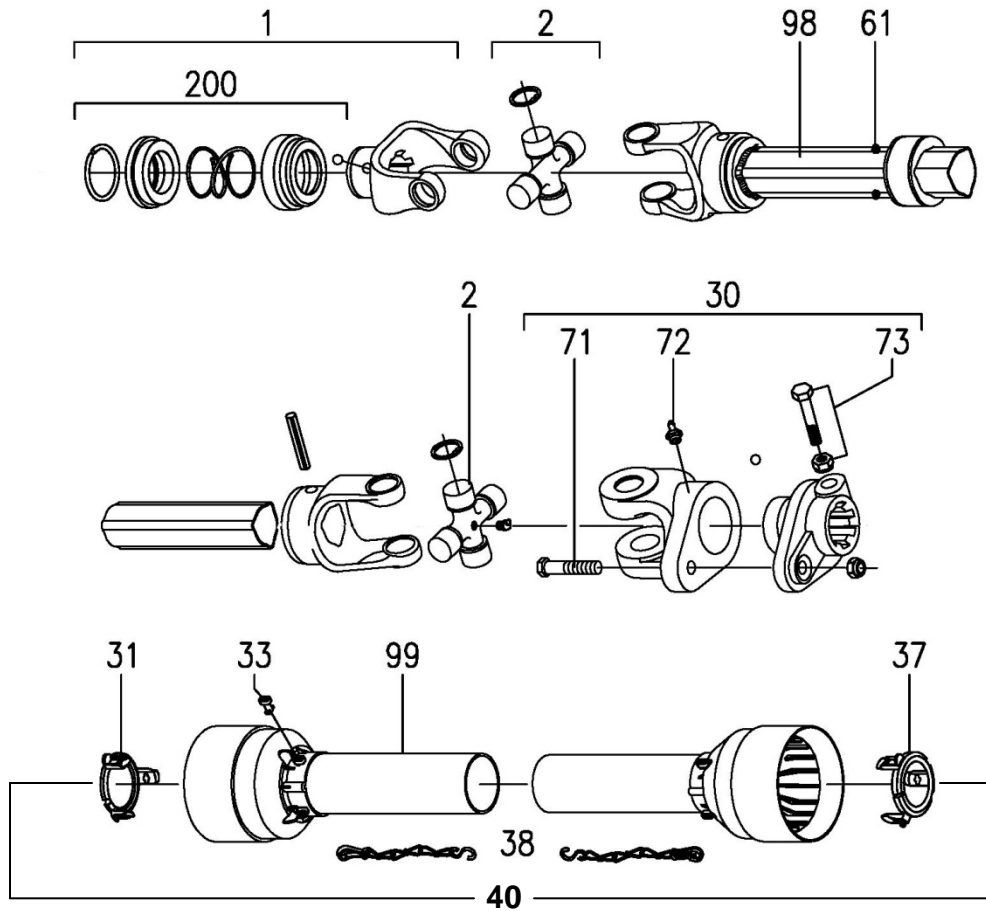

Item #	Description	Part#	Req
1	Complete Collar Yoke	141.025.363.1	1
2	Cross Journal Assy	180.015.130	2
30	Complete Shear Yoke	143.250.016.1	1
31	Guard Retaining Collar for Outer Tube	8180.015.288	1
33	Special Plastic Bolt	8180.014.240	6
37	Guard Retaining Collar of Inner Tube	8180.015.289	11
38	Safety Chain	180.016.025	2
40	Complete Guard with Instruction Manual	142.250.372.7521	1
61	Special Grease Nipple	8180.012.418	3
71	Bolt & Nut M10x55 cl. 8.8	165.000.511	1
72	Grease Fitting	190.000.020	1
73	Bolt & Nut M12x1.25x70 cl. 8.8	165.000.525	2
200	Collar Kit for 1 3/8" Yoke	165.000.628	1
	Danger Label for Outer Tube	190.000.216	1
	Danger Label for Outer Guard Tube	190.000.215	1
	PTO Instruction Manual	190.000.371	1



PTO Installation Instructions for Snowblower

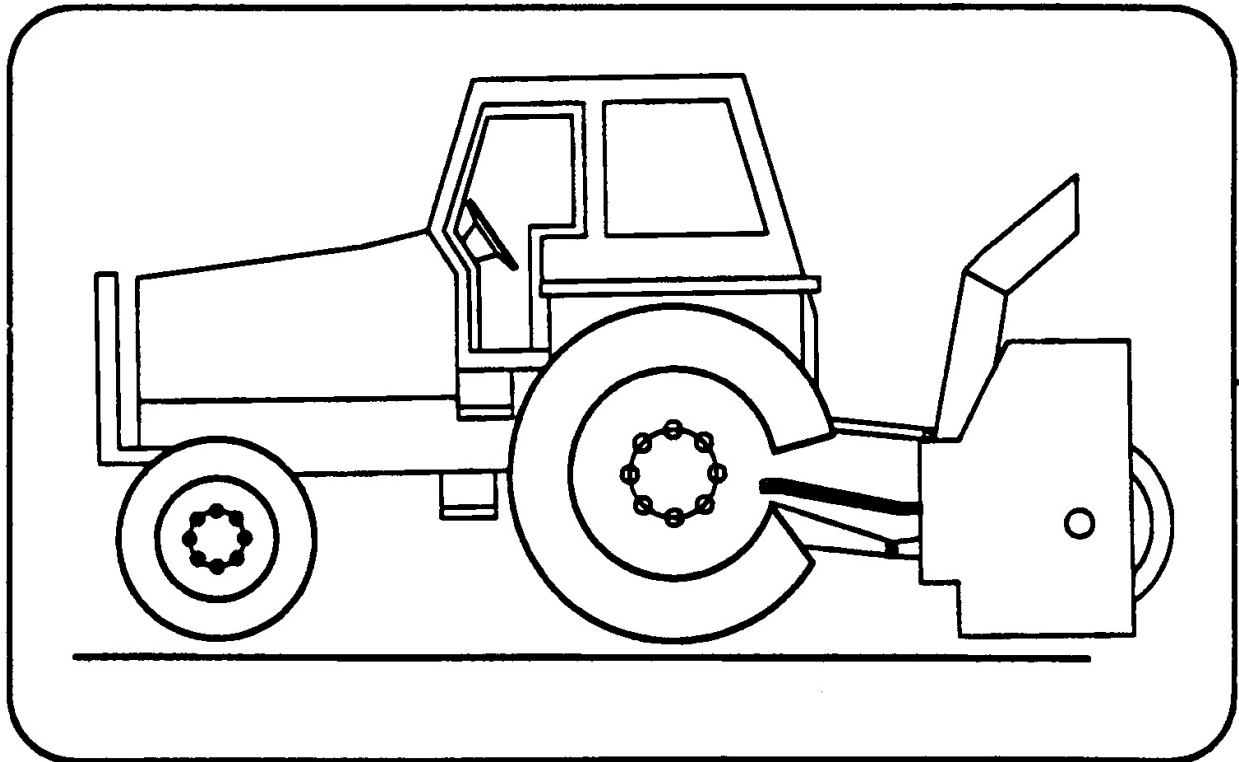

**PTO Installation Instructions for Snowblower
For Better PTO Shaft and Gearbox Operation**

A proper initial installation will give you years of satisfactory service on your equipment. Please read carefully, following instructions which have been specially made to help you and make you satisfied of your purchase.

Warning! Unfortunately, snowblowers will be faced with forgotten or hidden objects under the snow, such as: chain, tires, stones, pieces of wood, etc. In spite of all our efforts, machines are not built to resist all those conditions.

Danger: Too big tractors

It is dangerous to use a that is too big or too powerful. The tractor will always be able to overload the blower, even if the machine is already at maximum capacity. Tractor being very high, too large angles at PTO universal joints will result, and the life of the universal joints will be shortened dramatically.

P T O Shaft angles

PTO shafts are made to transmit power with angle at universal joints. However these angles should be kept to a minimum. Larger angles shorten the life of PTO. Take for example a snowblower sold for a tractor horse-power of 60-75 HP which would be attached to a 60HP tractor operating at maximum capacity of (60HP continuous).

HP	PTO angles	Estimated life in hours
60@540 RPM	5°	450 hours
	10°	195 hours
	15°	90 hours
	20°	40 hours
	25°	20 hours

How to determine PTO angle

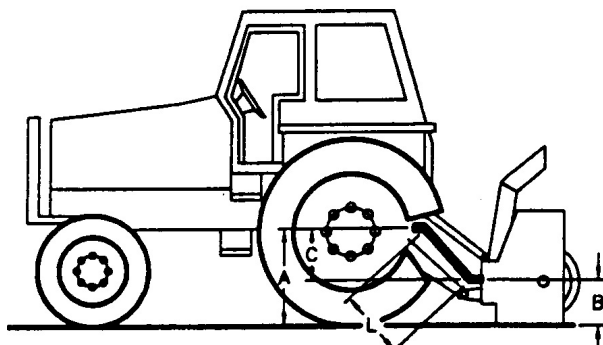

- A** =PTO height at tractor
- B**= PTO height at blower
- C**= A-B
- L** = Cross center distance in working position

- 1) Lower blower on ground
- 2) Measure A,B and L
- 3) Subtract B of A (A-B=C)
- 4) Divide L by C (L/C=F)
- 5) Compare F Factor in the table below to find PTO angle. (Interpolate if necessary)

F Factor	Angle
6	10°
3.75	15°
2.75	20°
2.15	25°
1.75	30°

Previous examples clearly demonstrate that universal joint angle is directly related with life of PTO. In order to reduce angle, it is necessary to increase the angle between snowblower and tractor.

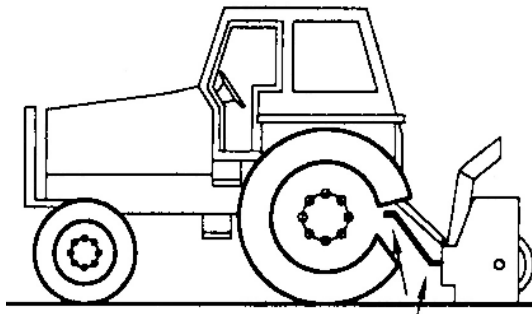

**Too Large Angles at PTO Joints
To Avoid**

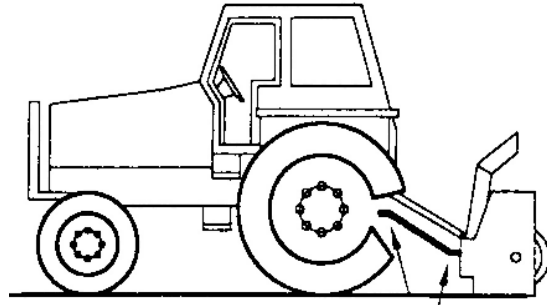

**Reasonable Angles at PTO Joints
Acceptable**

If it is impossible to increase the distance between snowblower and tractor, in order to maintain a reasonable angle at the PTO, it is recommended to use a larger size PTO that is a greater capacity PTO. (please refer to your dealer for more details).

For snowblowers of 100HP, an additional gearbox is also available that can be mounted on the existing snowblower gearbox, which increases the input shaft height, reducing the angle at PTO joints. This Gearbox has an input speed of 1000RPM which greatly increases PTO capacity.

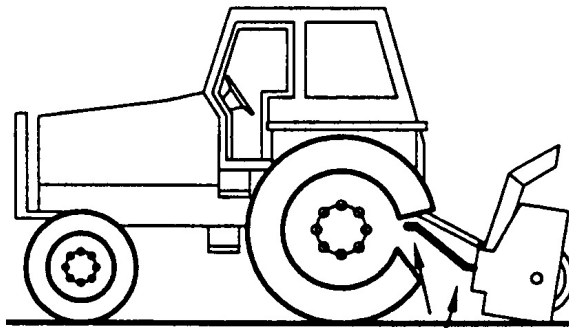

**Non-Equal Angles at PTO Joints
To Avoid**

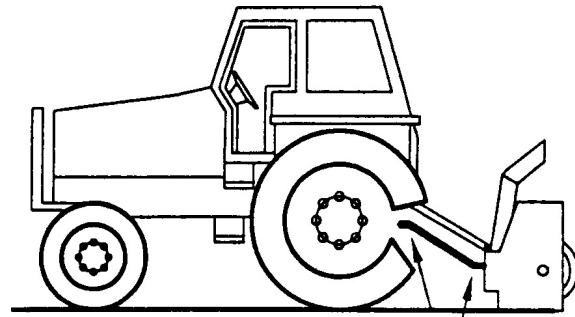

**Equal Angles At PTO Joints
Recommended**

Angles at each end of PTO

A popular habit is to change snowblower angle in order to obtain a better scraping effect. This practice can become harmful to the PTO if the angle is unequal at each end, There will be fan speed variation (as the fan speed up and slow down twice per revolution) as well as a drastic increase of loading on the cross and bearings. **To avoid** it is recommended to keep tractor PTO and snowblower input shaft always parallel.

Shear Bolts

Shear bolts are built to break under shock loads on the fan or auger. However under certain circumstances this security is not adequate. Example: a sudden high impact shock on the fan may, in some cases break the fan shaft without breaking the shear bolt.

If the shear bolt breaks, make sure to always replace it with the same grade of category bolt (grade 5 for PTO series **20-40-50-60**, and grade 8 for PTO series **80**) it is necessary to always maintain this bolt very tight in order to keep the efficiency of the shearing mechanism.

Warning: The gearbox shafts are made with special alloy steel. However they are case hardened to increase capacity to shock load. These shafts cannot be broken under normal loads. However undesirable objects may enter the fan and either bend or break the gearbox shaft. It is understood that the gearbox cannot be built to resist every possible overload and consequently, gearbox fan shafts will not be replaced under warranty. Therefore the user of the snowblower must be very careful.

Maximum length of PTO shaft

Warning: Telescopic tubes of PTO should overlap a minimum length to meet ideal conditions for transmitting power.

Following table could be used as a guide to find maximum permissible length of PTO.

PTO Description	Over-all length Closed	Over-all length Opened Max	Telescopic tube overlap
T20-056P	29 3/4"	41"	5"
T40-056P	30 1/2"	40 1/2"	6"
T50-071P	36 1/2"	51 1/4"	7"
T60-071P	37 3/4"	51 1/4"	7"
T80-066P	36"	47 1/4"	7"
T80-076P	40 1/2"	53"	8"
T90-071P	39"	51"	8"





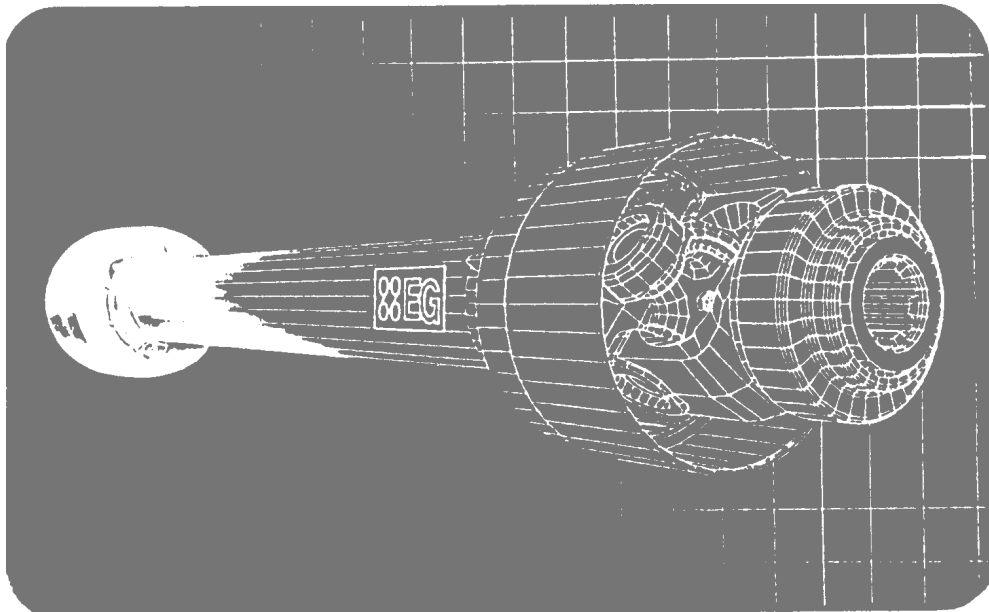

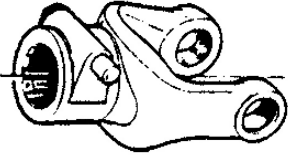
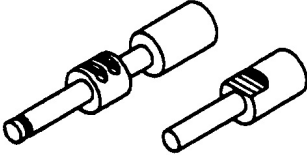
Effective PTO Drive Shaft Maintenance



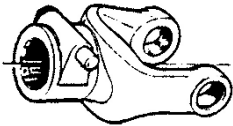

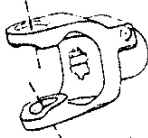
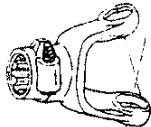

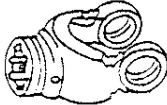
	Avoidable Damage	Possible Causes	Corrective Actions
Quick-disconnect yoke 	Quick-disconnect pin tight or completely seized Quick-disconnect pin damaged (broken or bent) Quick-disconnect pin damaged in locking position 	Quick-disconnect pin dirty (insufficient maintenance) Quick-disconnect pin defective (forced into place, incorrect handling). Excessive shaft length Axial load too high	Clean, oil and follow service instruction Replace Quick-disconnect pin Shorten shaft length (cut both telescopic tubes as well as shield, remove burrs) Replace Quick-disconnect pin Clean and grease telescopic tubes. Replace both tubes if necessary

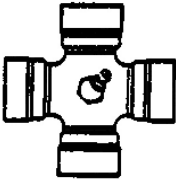
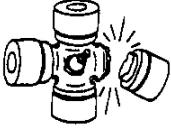
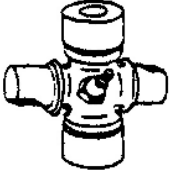
Note: newer PTO shafts may have a locking collar. (Damages Causes and corrective actions will still be similar.

	Avoidable Damage	Possible Causes	Corrective Actions
Yoke  	Deformed Yoke  	Excessive shaft length Axial load too high Excessive working angle and torque	Shorten shaft length (cut both telescopic tubes as well as shield, remove burrs) Replace defective yokes Clean and grease telescopic tubes. Replace both tubes if necessary Replace defective yokes Verify compatibility between shaft and working conditions (torque vs. angle) Disengage tractor PTO during lifting or lowering the implement. Change to a larger PTO size
	Distorted Yoke 	Overload caused by high starting and peak torque	Engage PTO more carefully Use appropriate safety device Replace defective yoke
	Worn or pounded Yoke 	Excessive working angle	Avoid excessive angle Replace defective yokes

	Avoidable Damages	Possible Causes	Corrective Actions
<p>Cross Kit</p> 	<p>Cross Arms broken</p> 	<p>Extreme torque peak or shock load</p> <p>Axial loads too large</p>	<p>Use appropriate safety device</p> <p>Change to a larger PTO size</p> <p>Shorten PTO shaft</p> <p>Replace defective cross bearings</p>
	<p>Bearing caps turning in their cross journal</p> <p>Overheated bearing caps</p>	<p>Excessive continuous torque and/or excessive working angle</p> <p>Inadequate greasing</p>	<p>Verify compatibility between shaft and working conditions</p> <p>Carefully follow greasing instructions</p> <p>Replace defective cross bearings</p>
	<p>Accelerated wear of cross kit</p> 	<p>Excessive continuous torque and/or excessive working angle</p> <p>Inadequate greasing</p>	<p>Verify compatibility between shaft and working conditions</p> <p>Carefully follow greasing instructions</p> <p>Replace defective cross bearings</p>

Note: Cross bearings must be greased every 8 working hours

	Avoidable Damages	Possible Causes	Corrective Actions
<p>Telescopic tube</p> 	<p>Telescopic tube failure or twisting</p> 	<p>Excessive torque or shock load</p> <p>Short tube engagement (overlap)</p>	<p>Use appropriate safety device</p> <p>Change to a larger PTO size</p> <p>Replace the PTO drive shaft with one of adequate length</p> <p>Replace defective tubes</p>
	<p>Accelerated wear of telescopic tubes</p> 	<p>Accelerated wear of telescopic tubes</p> 	<p>Extreme load when sliding</p> <p>Short tube engagement</p> <p>Inadequate greasing</p> <p>Conditions (sand etc)</p>

Note: Telescopic tubes must be cleaned and greased every 16 working hours

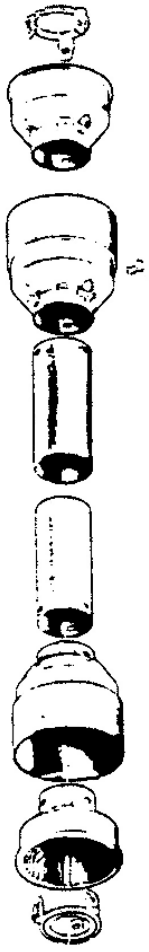
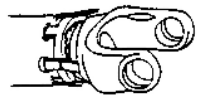
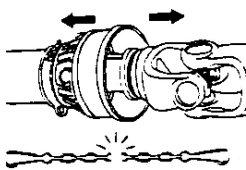
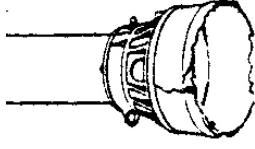
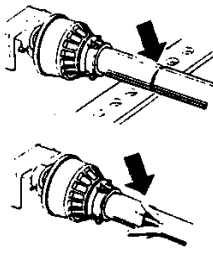
	Avoidable Damages	Possible Causes	Corrective Actions
	Excessive wear of shield bearings 	Insufficient lubrication Incorrect chain mounting Shield interfering with implement	Follow lubrication instructions Mount chain to allow maximum angularity Avoid shield contact with machine or tractor Replace shield bearings
	Chain failure 	Shield interfering with implement Incorrect chain mounting	Avoid shield contact with machine or tractor Mount chain to allow for maximum angularity Replace defective parts
	Guard cone damaged 	Guard cone in contact with implement or tractor Excessive angularity	Eliminate interference between guard cone and any part of implement or tractor Avoid excessive angles Replace damaged guard cone
	Guard tubes damaged (deformed and split at one side) 	Guards are in contact with tractor or implement Guard tube overlap too short or no overlap with PTO tube extended	Eliminate interference between guard cone and any part of implement or tractor Replace damaged tubes Adjust guard tube length with longer tubes

Note: Shield bearing must be greased every 8 working hours

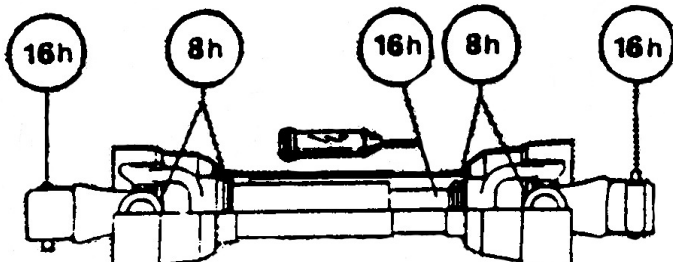

Bolt Torque
As used on this equipment

Bolt torque table shown below gives torque values for the various bolts used. This chart is for non-lubricated threads. Replace with the same strength bolt.

Torque Specifications. Torque values are identified by their head markings

Diameter	SAE 2		SAE 5		SAE 8	
"A"	Lb-ft	N.m	Lb-ft	N.m	Lb-ft	N.m
1/4	6	(8)	9	(12)	12	(17)
5/16	10	(13)	19	(25)	27	(36)
3/8	20	(27)	33	(45)	45	(63)
7/16	30	(41)	53	(72)	75	(100)
1/2	45	(61)	80	(110)	115	(155)
5/8	95	(128)	160	(215)	220	(305)
3/4	165	(225)	290	(390)	400	(540)
1	225	(345)	630	(850)	970	(1320)

Allen head cap screws are similar to SAE 8 quality.

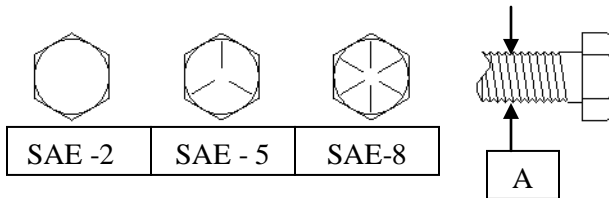

These torques are for a reference only. Not all these sizes and grades are necessarily used in this machine. Bolts that are used as a pivot or hinge have to be used with a locknut, therefore only tighten enough to secure the bolt and still allowing the part to rotate freely.

87D Meteor Snowblower

Maintenance

- PTO Shearbolt – M10x50 - - 8.8
- Auger Shearbolt – 5/16 x 1 1/4” Gr #2
- Auger Drive Chain Tightener – tighten chain allowing ¼” sag in the bottom span of chain (between drive and driven sprocket).

Lubrication

- Gearbox- check oil level every **50** hours. Fill to oil level plug (middle of gearbox) with SAE 90 gear oil. SAE 80W90 gear oil may also be used.
- Auger and Shear Sprocket Bearing – grease sparingly every **50** hours. (By using too much grease you will push the seals off the bearing).
- PTO Shaft – grease every **10** hours. Pull apart and apply grease to the sliding members. Grease the yoke bearings at this time as well.
- Auger Chain – apply oil on a regular basis especially after using the snowblower.

Storing the Meteor Snowblower in the off season

- At the end of the season lubricate the Bearings, PTO shaft and Auger chain before storing it.

Notes

Part numbers – Abbreviations

O/L – obtain locally

N --- Nut

LW- Lockwasher

- All fasteners are Grade #2 unless otherwise specified.
- Customer supplies hydraulic cylinders.