

Cannon[®]

Canterbury Freestanding Instruction Manual

Please read this manual before installing and using this heater.



Model: CANTFS-SDEEB

Distributor
This appliance is designed, manufactured and distributed by:

Sampford IXL

Tel: 1300 727 421

Please leave instruction manual with the owner

CONTENTS	PAGE
WARRANTY	3
SAFETY WARNINGS	5
OPERATION	6
OPTIONAL ACCESSORIES	7
CANTERBURY FREESTANDING SPECIFICATIONS	8
CANTERBURY FREESTANDING INSTALLATION INSTRUCTIONS	9
FRONT GLASS REMOVAL AND INSTALLATION	10
FLUEING INSTALLATION	11
ELECTRICAL CONNECTION AND GAS CONNECTION	12
LOG INSTALLATION	13
SETTING THE GAS PRESSURE	14
SERVICE INSTRUCTIONS	15 –16
WIRING DIAGRAM	17
TROUBLESHOOTING	18 – 19

WARRANTY

This Warranty against defects for your newly purchased Cannon product is proudly prepared by Sampford IXL Pty Ltd of 421 Smith Street, Fitzroy, VIC 3065, phone 1300 727 421.

1. Sampford IXL products come with guarantees that do not exclude the following consumer entitlements under the Australian Consumer Law:
 - a. replacement or refund for a major failure and compensation for any other reasonably foreseeable loss or damage; and
 - b. to have the goods repaired or replaced if goods fail to be of acceptable quality and the failure does not amount to a major failure.
 2. Sampford IXL warrants that your product and related supply will be free from defects in materials and workmanship during the warranty term. Your warranty term can be found in your original instruction booklet contained in this box, commencing from the date of purchase. Sampford IXL acknowledges this product requires professional installation and product removal is hazardous to consumers, accordingly any necessary inspections and services will be carried out on site. You should not attempt de-installation.
 3. Subject to Point 1, Sampford IXL will repair any defects in materials and workmanship during the warranty term and if the product is deemed irreparable provide a replacement of an equivalent current model where the balance of the warranty period from the original date of purchase will take effect.
 4. To the fullest extent permitted by law and subject always to Point 1, Sampford IXL will not be liable for:
 - a. any loss or damage arising from loss of use, loss of profits or revenue; or
 - b. for any indirect or consequential loss or damage resulting from any breach of this warranty against defects.
 5. Defective Sampford IXL products may be repaired using refurbished parts or if required, completely replaced by a refurbished product of the same type.
- c. will not apply where the defect in or failure of the product is attributable to misuse, abuse, accident or non-observation of the manufacturer's instructions. This product must be used in accordance with the manufacturer's instructions;
 - d. will not cover faults due to normal wear and tear with reasonable use nor consumable components such as globes, filters, glass items, etc;
 - e. will not cover any damages or problems caused to this product by natural forces eg. storm, fire, flood, and earthquake; or by intrusion or accumulation (or both) of foreign matters eg. dust, soil, and moisture. Sampford IXL recommends that you take out appropriate insurances to protect your product to this end;
 - f. will not apply if this product is installed in a mobile dwelling eg. caravan or boat;
 - g. will not apply if this product is removed from the location where it was first installed;
 - h. is immediately void if the serial or model number label is removed or defaced;
 - i. is immediately void if the product is serviced or repaired by a unauthorised/unqualified personnel;
 - j. covers use of this product for domestic use only;
 - k. will not be restarted or extended upon repair or replacement of the product or a part.

How to Make a Claim Under Your Cannon Warranty

7. To make a claim under this Warranty you will need to:
 - a. contact Sampford IXL service department on 1300 727 421 or aftersaleservice@sampfordixl.com.au to provide details and register your claim enabling a Sampford IXL assessment;
 - b. submit proof of purchase with your claim eg. tax invoice or purchase receipt;
 - c. where a property has been constructed by a builder/developer and it is fitted with IXL products, please submit proof of purchase by way of the certificate of occupancy, with your claim.
 8. Sampford IXL will contact you to make arrangements for service on site.
 9. Subject to Point 1, you will be responsible for any costs relating to the provision of your product to a Sampford IXL Authorised Service Dealer.
 10. Subject to Point 1, in the event you live more than 50 km from a Sampford IXL Authorised Service Dealer you may be subject to travel or transport costs to facilitate the repairing or replacement of your IXL product.
6. Subject to Point 1, this Warranty:
- a. will only be provided to the original purchaser where the original purchase was made from a Sampford IXL Authorised Dealer or Reseller and proof of such purchase can be presented at the time of service;
 - b. only applies to Sampford IXL products purchased in Australia from a Sampford IXL Authorised Dealer or Reseller and installed by a qualified person where a Certificate of Compliance in accordance with State/Territory laws is provided;

Limitations to Your Cannon Warranty

11. Sampford IXL and its Authorised Service Dealers reserve the right to seek reimbursement of any costs incurred by them should your Cannon product be found to be in good working order.

Privacy

The privacy of your personal information has always been important to us. To learn more about how we collect, keep and use your personal information, please obtain a copy of our privacy statement by visiting our website at www.sampfordixl.com.au or by contacting us via email on info@sampfordixl.com.au or by telephone on 1300 727 421.

Enter the details of the date installed and the Compliance Certificate number in the appropriate area on the rear page of this manual.



- DO NOT** operate this appliance before reading the instruction booklet.
- DO NOT** place articles on or against this appliance.
- DO NOT** store chemicals or flammable materials, or spray aerosols near this appliance.
- DO NOT** operate with panels, covers or guards removed from this appliance.
- DO NOT** connect an LP gas cylinder located indoors.

Don't risk your appliance warranty
Only a licensed person will give you a Compliance Certificate, showing that the work complies with all the relevant standards.
Only a licensed person will have insurance protecting their workmanship for 6 years.
You **MUST** use a licensed person to install this appliance who **MUST** give you your Compliance Certificate to ensure the manufacturers appliance warranty will be honoured.

SAFETY WARNINGS

Please read this manual before installing and using the heater.

Safety Warnings

1. What to do if you smell gas

- (a) Turn OFF the main gas supply
- (b) Extinguish any open flame
- (c) Open windows
- (d) Do not touch electrical switches
- (e) Do not use your telephone
- (f) Call your gas supplier immediately from a neighbour's phone

2. Improper installation, adjustment, alteration, service or maintenance can cause injury or property damage. Refer to the sections of this manual for correct procedures, or consult with place of purchase, a licensed plumber, a gas supplier or the CANNON distributor listed in this manual.

3. Do not build this heater into bookcases or walls. Install only in locations as referred to in these instructions.

4. Due to high temperatures the room heater should be located out of traffic and away from:

- Furniture and draperies
- Combustible materials
- Gasoline and other flammable liquids

Do not place clothing or other flammable material on or near the heater.

5. Keep curtains*, clothes, furniture and other flammable materials at least 900mm from front and sides of heater.

* At the owner's discretion curtain clearance can be less than 900mm as long as they are restrained from the front, top and sides of the heater. The manufacturer takes no responsibility if curtain clearance is less than 900mm and not restrained.

6. Children and adults should be alerted to the hazard of high surface temperature and should take care to avoid burns or clothing ignition.

This appliance is not intended for use by persons (including children) with reduced physical, sensory or mental capabilities or lack of experience and knowledge, unless they have been given supervision or instruction concerning use of the appliance by a person responsible for their safety. Children should be supervised to ensure that they do not play with the appliance.

7. Never attempt to burn paper or any other material in the heater.

8. **Do not** place articles on or against this appliance.

Do not use or store flammable materials near this appliance.

Do not spray aerosols in the vicinity of this appliance while it is in operation

Do not modify this appliance.

9. If removed, the glass window must be put back onto the unit prior to operating the heater.

10. Installation and repairs should be performed by a licensed service person only, refer to back of brochure for service number.

11. The heater must be properly connected to a flue system (purchase separately to heater). Operation of this heater, when not connected to a properly installed and maintained flue system can result in carbon monoxide (CO) poisoning and possible death.

12. Testing the effectiveness of the flue. Before testing the flue confirm air vents are unobstructed. If an extraction system or other heating appliances are present switch them on. This is to test that there is no interaction between the Cannon heater and other appliances.

Refer to Australian Standard Gas Installations AS 5601.

For 'air movement not to affect appliance'.

For 'air supply to appliance'.

For 'ventilation requirements'

13. On first lighting your heater an odour and possibly some harmless smoke may be emitted due to its new condition. This is quite normal and will disappear after a few hours use.

Important: When this heater is operating the mesh guard/glass front is hot. The mesh guard, or glass front is fitted to this appliance to reduce the risk of fire or injury from burns and no part of it should be permanently removed. For protection of young children or the infirm, a secondary guard is recommended (not supplied with heater).

This appliance meets the following standards:

Standards Australia

AS/NZS 3100

AS 5601

AS 4553:2008

OPERATION

Operating Instructions

Plug the power cord into the switch socket and turn on the power to the heater (**FIG 1**). Alternatively, switch on the isolation switch and circuit breaker at the main switchboard if the heater has fixed wiring. Refrain from using an extension cord.

User controls **FIG 2**.

When there is power available to the heater and it is in the off or Standby mode, a red LED located inside the ON/OFF button will flash twice and will extinguish for approximately 3 seconds and then repeat this cycle continuously.

To turn the heater ON press the ON/OFF button once.

- The LED will illuminate and an audible beep will sound but there will be approximately 5 seconds delay before the ignition system commences. On successful ignition the heater will operate on Low Fire and Low Fan for approximately 3 minutes then will switch to selected setting (if already chosen, otherwise it will switch to NORMAL setting automatically).
- The LED will extinguish approximately 30 seconds following the ignition startup.
- Select the desired heating level by pressing the LOW, NORMAL or BOOST button once as required.
- LOW is LOW heat and LOW speed fan. BOOST is High heat and High speed fan.
- To turn the heater OFF press the ON/OFF button once. An audible beep will sound twice to indicate the heater is off. The burner will extinguish but the fan will continue to operate for approximately 3 minutes. Remember that the fan will continue to operate for approximately 3 minutes after the OFF button has been pressed but you can turn the heater ON again without having to wait for the fan to stop operating.
- If the ignition system fails to ignite or keep the burner alight, the system will beep 4 times and go into safe shutdown mode. It will beep 4 times every 30 seconds to alert you to the fact. Press the ON/OFF button once to restart the heater during this time. You **MUST** wait at least 5 minutes before trying to turn the heater on again if there have been several attempts to ignite the heater without success.

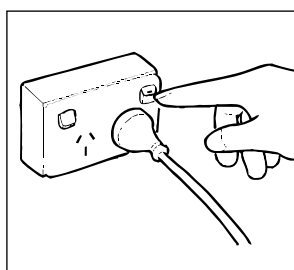

FIG 1

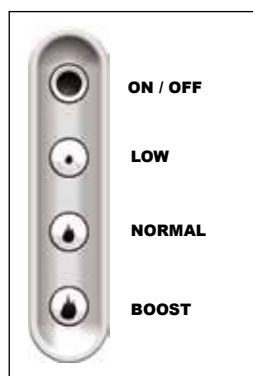

FIG 2

- If there is an interruption to the power supply the heater will fail safely and switch off. When the power supply has been restored you **MUST** wait at least 5 minutes before turning the heater ON.

Cleaning

All cleaning should be carried out when the heater is cold. Normally the heater should only need wiping with a lint-free damp cloth. Any stubborn stains can be removed with a nonabrasive spray on cleaner. If an abrasive cleaner is used the paint finish will be damaged.

For heaters fitted with the glass front: All cleaning should be carried out when the heater is cold. Clean the outer glass with a mild liquid or spray on glass cleaner. Do not use harsh abrasive cleaners or sharp metal scrapers to clean the heater glass front since they can scratch the surface, which may result in shattering of the glass.

Internally the heater should only be cleaned by an authorised service person listed in this manual. If your heater requires attention contact your supplier or authorised service person listed in this manual.

Flame Characteristics

The heater flame should be stable, not lifting from the burner. The logs should glow after approximately 15 minutes operation on BOOST setting.

The heater is designed to operate with luminous flames and may exhibit slight carbon deposit on the logs. If there is any excess carbon build-up on logs, or the burner flame is unstable, contact Sampford IXL in your state.

Important

The appliance **MUST be serviced at least annually by an authorised service person. This maintenance cost is not covered under the warranty terms and conditions. More frequent cleaning may be required due to excessive lint build-up from carpeting, bedding materials, pet hair, etc.**

It is imperative that control compartments, burners and circulating air passage ways of the appliance be kept clean.

Do not use this heater if the glass is cracked or with the safety screen removed.

Do not use heater with broken or missing logs.

High wind gusts can affect the heaters flueing and switch the heater off. If this happens, restart the heater as normal. If the problem persists contact Sampford IXL.

OPTIONAL ACCESSORIES

Every Cannon heater brings you the optional convenience of being controlled via a remote thermostat.

For added convenience the heater can now be connected to a home automation system, such as C-bus. This allows the heater to be turned on or off remotely (normal heat setting only). Speak to your home automation specialist for further information.



Remote thermostat



Canterbury mesh guard

Product codes

- Remote thermostat: RTKIT
- Canterbury mesh guard: CANTFSMG-B
- Flue Kit: FLUERO-B
- Extra flue length: FLUEFL-B
- Cathedral ceiling flue box: BOX-B

Flue kit includes: (purchase separately)

- 3 x 870mm lengths of 125mm dia. painted flue
- 1 x 870mm length of 125mm dia. plain flue
- 1 x Ceiling ring
- 1 x 125mm cowl
- 1 x painted bottom flue spigot

CANTERBURY FREESTANDING SPECIFICATIONS



Cannon Canterbury Freestanding

Gas type	Natural or Propane gas, as indicated on data plate
Gas consumption	26 MJ/hr input
Energy output	5.98 kW / 21.45 MJ/hr
Energy star rating	4.06 stars
Heater type	Gas space heater approved to AS4553:2008
Operating pressure	Natural gas: 0.75 kPa (high)/ 0.40 kPa (low) Propane gas: 2.65 kPa (high)/ 1.1 kPa (low).
Gas regulator	Integral part of controller
Min. inlet pressure	1.13 kPa (Nat Gas) 2.75 kPa (Propane)
Fan	3 speed
Ignition	Electronic direct spark
Power requirement	240 VAC 10 Amp switch socket
Power consumption	90 VA maximum
Optional accessories	<ul style="list-style-type: none"> • Clip on mesh safety guard • Cathedral ceiling flue box • Remote control thermostat
Flue kit (purchase separately)	<ul style="list-style-type: none"> • 3 x 870mm lengths of 125mm ø painted flue • 1 x 870mm length of 125mm ø plain flue • 1 x ceiling ring • 1 x flue spigot adaptor • 1 x 125mm ø flue cowl
Overall dimensions	Refer to FIG 3

Please note: The data label is located on the left hand side panel near the electronic control box.

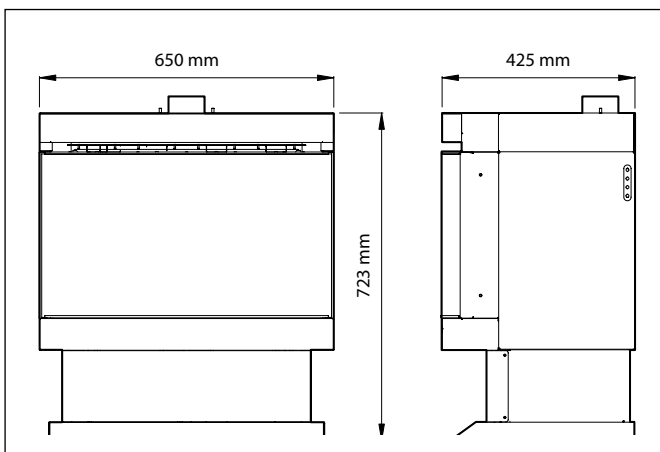

FIG 3 Back View and Side View

CANTERBURY FREESTANDING INSTALLATION INSTRUCTIONS

Overview

1. This appliance MUST be installed by a suitably licensed person only.
2. This appliance shall be installed in accordance with these manufacturer's installation instructions, local gas fitting regulations, municipal building codes, electrical wiring regulations, and AS5601 the Australian Standard for gas installations. Refer also AS5601 for gas pipe sizing tables.

This heater is not suitable as a fire place insert.

Installation Instructions

Avoid installing the heater in front of the shortest wall of a high pitched roof as the possibility of down draught will cause problems with the heater operation and may not be fixable.

Ensure there are no obstructions around the cowl (i.e. overhanging tree branches).

Refer to the Australian Standard Gas Installations AS 5601: for 'location of flue terminal'.

Terminating a flue in a roof space is not permitted.

To avoid any unnecessary delays and inconvenience to your customer, please contact Technical Support on 1300 727 421 if the installation is unusual or you have any concerns with the installation and/or heater operation before the installation commences.

Make sure that the heater is fully commissioned and be certain to test the integrity of the flue operation, taking into account any influences created by range-hoods, exhaust fans, central heating, etc.

Any service request resulting from incorrect installations are not covered by our warranty conditions and these will result in charges, usually to the end user, so please be sure that the installation and commissioning has been satisfactorily carried out before calling for any warranty service.

Please ensure that the end user is fully instructed on how to operate the heater.

Clearances

1. Ensure the minimum clearances to combustible construction are maintained during installation, including adequate space for the proper operation and servicing of the heater.

For clearances to curtains and furnishings refer to warning 4 & 5 on page 5.

For minimum clearances refer **FIG 4** and **FIG 5**.

2. Remove the carton from the heater and lift heater from wooden pallet.

Check that the heater is suitable for the gas available. Refer to the data label located on the left side panel near the electronic control box.

(Please dispose of packaging appropriately, keep it away from children).

3. Prepare electrical and gas connections, a 10 Amp switch socket needs to be located within 1.5m of the heater.
4. Fit rear spacers as per **FIG 5**.

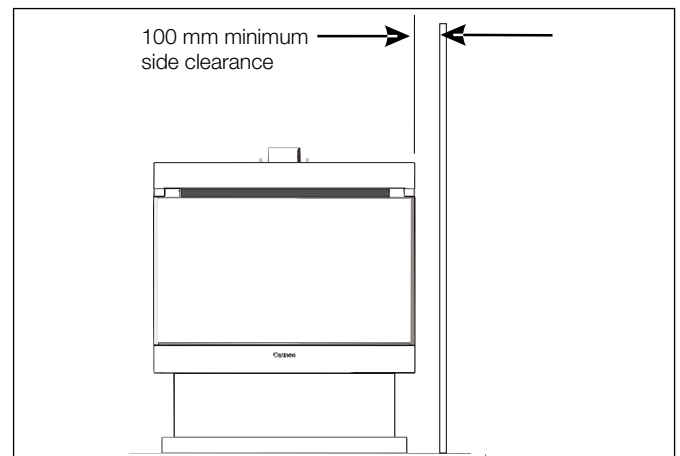

FIG 4

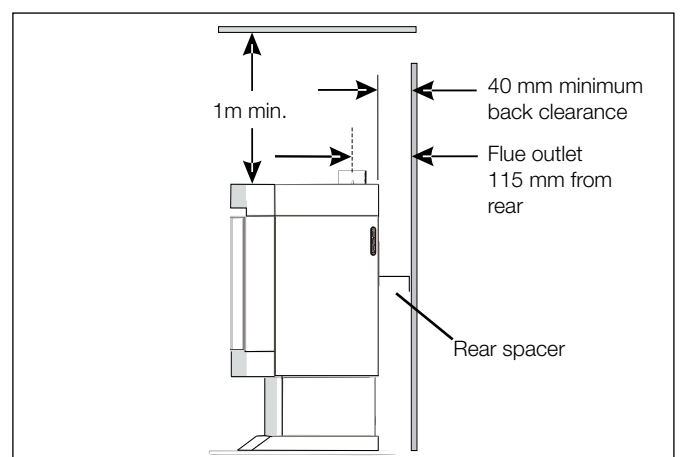

FIG 5

FRONT GLASS REMOVAL AND INSTALLATION

Front Glass Installation

1. Place heater in position. (Check flue and gas connection positions. Refer to gas connection instructions on page 12 and flue installation instructions on pages 11)
2. Remove the front glass surround by holding it firmly on either side and pulling it towards yourself. Refer **FIG 6**.
3. Remove the inner glass. Slacken off screws in top clamp and remove side clamps. Refer to **FIG 7**.

To Refit The Front Glass Surround

Ensure that the glass surround is replaced the correct side up. The rearward sloping frame must be at the top and the vertical edge must be at the bottom. Refer **FIG 8**.

This heater can be placed on either combustible or non combustible floor surfaces.

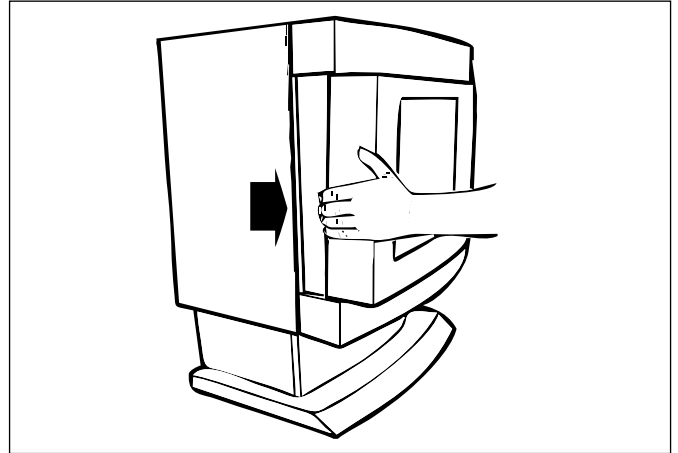

FIG 6

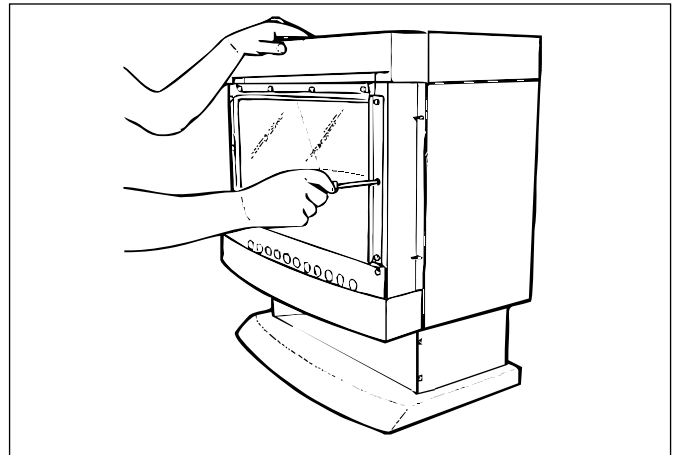

FIG 7

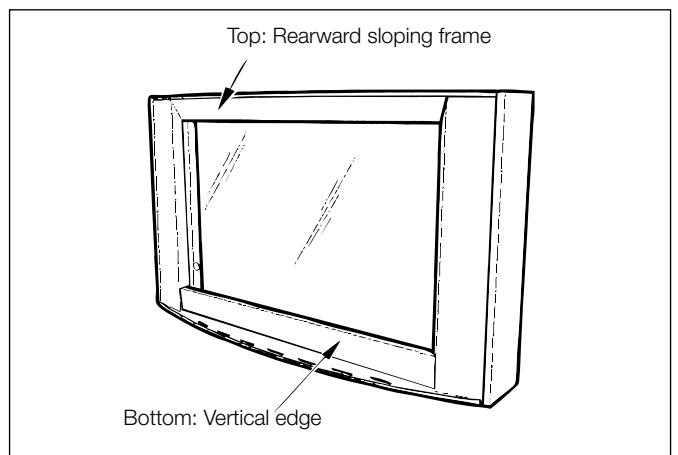

FIG 8

FLUEING INSTALLATION

This heater is a flued appliance. It must be properly connected to a flue system in accordance with the latest edition of the Australian Standard Gas Installations, AS 5601.

If elbows are required, we recommend 45° only and no more than two in the total flue run, there should also be a minimum of 250mm straight flue section in between bends.

If practical, locate the heater in a position to minimise the need for elbows.

There must be at least 1.8m of vertical flue before any changes in direction of the flue.

If placed against a combustible wall the 40mm rear spacers locate against the wall.

1. Ensure clearances to combustible constructions have been observed. For clearances refer page 9.
2. The centre line of the flue is 115mm from rear of appliance (including rear spacers).
3. Carry out installation as per **FIG 9** (ceiling plate installation) and **FIG 10** (flue installation).

Cut a hole 180mm \varnothing in the ceiling in line with the flue position. Secure ceiling plate against the ceiling by bending out the tabs above the ceiling.

Please note: If the ceiling has an incline, the ceiling box will need to be fitted. The ceiling box is an accessory and can be ordered from the supplier. Installation instructions are supplied with the ceiling box. Part no: BOX-B.

Flue kit

The flue kit contains:

- 2 x 870mm lengths of 125mm \varnothing painted upper flue.
- 1 x 870mm painted bottom flue spigot.
- 1 x 870mm length of 125mm \varnothing plain flue.
- 1 x ceiling plate.
- 1 x 125mm AGA approved gas cowl.

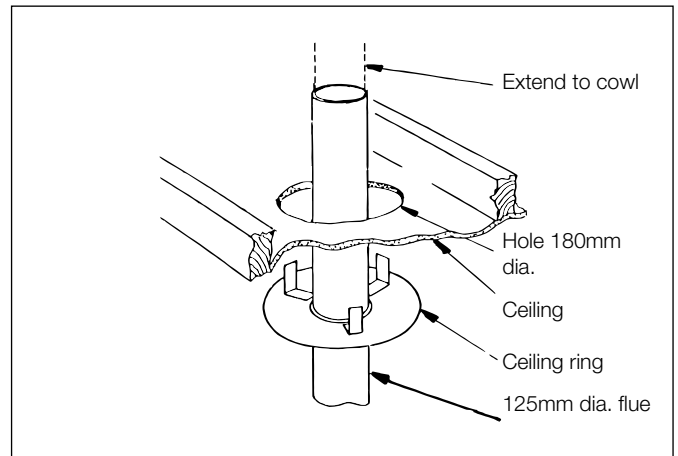

FIG 9

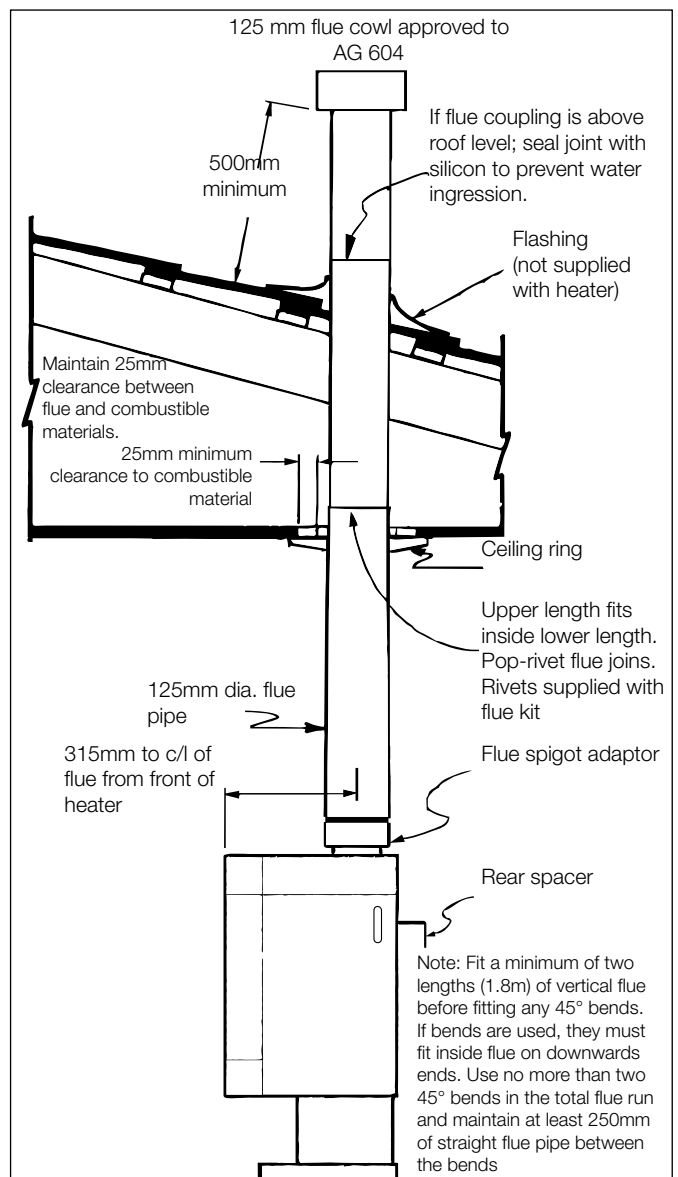

FIG 10

ELECTRICAL CONNECTION

Electrical Connection

This appliance is designed to operate on 240V AC power supply. Failure to operate unit at correct supply voltage may create unsafe conditions.

The heater is supplied with a flexible power cord with a plug fitted. A 10 Amp switch socket must be located within 1.5m of the heater.

A suitable double pole isolation switch must be installed externally for servicing or emergency shut down of the heater.

All fixed wiring must be installed by a suitably qualified person and comply to the appropriate electrical wiring rules.

It is critical that the appliance is earthed and that the active and neutral are not reversed. Issues arising from incorrect electrical wiring at premises will not be covered under warranty (including use of extension cords). We recommend that the heater is connected directly to a switch socket by its own power cord. Refrain from using extension leads.

GAS CONNECTION

Connect incoming gas supply pipe to 1/2" compression fitting at rear of appliance. For inlet position refer **FIG 11**.

Solid copper pipe to be used only.

Heater is not to be connected using a flexible hose.

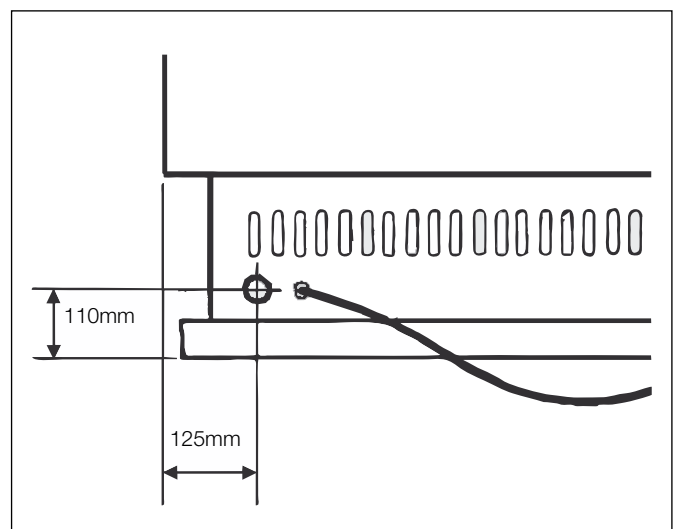

FIG 11

LOG INSTALLATION

1. The burner is contained within the burner chamber.
Refer **FIG 12**.
2. Carefully unpack the log set. Logs are numbered as follows:
 - #1 - Left front log
 - #2 - Left back log
 - #3 - Right front log
 - #4 - Right back log

Position the four individually numbered logs in the following order on the burner bed as shown in **FIG 13-16**. The locating pins on burner bed must engage with corresponding holes in the individual logs.

- a) Place log #1 into the 2 front left pins on the burner bed, ensuring that the charring faces the front.
Refer **FIG 13**.
 - b) Place log #2 onto the 2 left back pins. Refer **FIG 14**.
 - c) Place log #3 on single right front pin, ensure fork locates over log #2. Refer **FIG 15**.
 - d) Place log #4 on single right back pin, ensure left side of log rests on depression in #3 log. Refer **FIG 16**.
3. Refit the inner glass, making sure not to over tighten the screws.
 4. Refit the front glass surround.

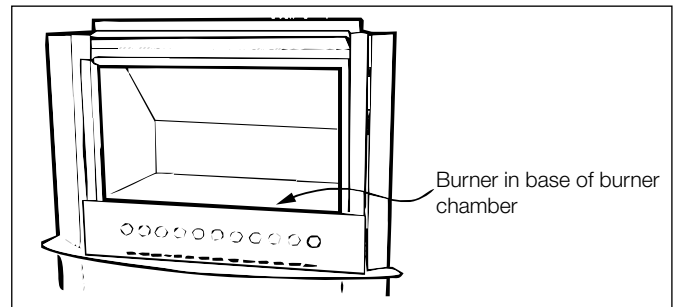

FIG 12

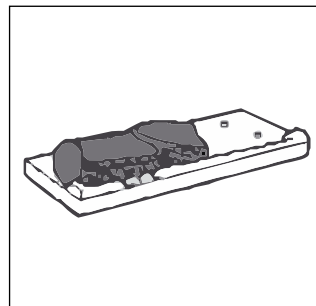

FIG 13

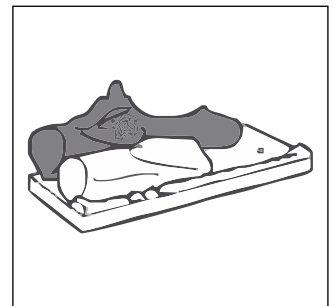

FIG 14

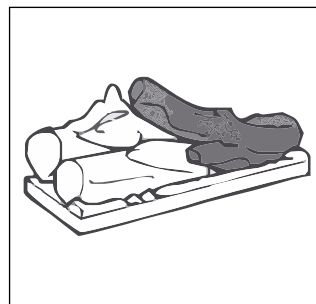

FIG 15

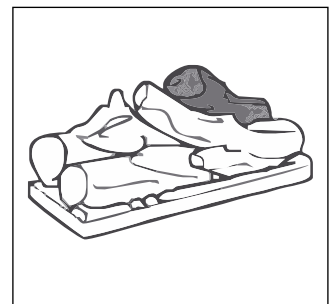

FIG 16

SETTING THE GAS PRESSURE

- Gas valve layout is as indicated in **FIG 17**. Pressures for 'Burner high flame' and 'Burner low flame' are factory set, however if pressures need to be checked or adjusted follow the procedures described below. To check outlet pressure at burner 'high flame' and 'low flame' positions remove the plastic cap from the regulator adjustment location as indicated in **FIG 18**.
- The pressure point is closed with a captive screw. Turn screw 6 revolutions anticlockwise to open the pressure point as indicated on **FIG 19 (a)** and place manometer tube over the test point as per **FIG 19 (b)**.
- Switch the control buttons to 'High flame' position. Wait for heater to switch to 'BOOST' setting (time delay on startup). Retain screwdriver in position and using a spanner adjust the outer nut on the control to give a high pressure reading (refer to spec table on page 8). **(Turn clockwise to increase pressure and anticlockwise to decrease pressure)**. Refer **FIG 20**.
- Switch the control buttons to 'Low flame' position. Retain spanner in position and using a screwdriver adjust the central screw control to give a low pressure reading (refer to spec table on page 8). **(Turn clockwise to increase pressure and anticlockwise to decrease pressure)**. Refer **FIG 21**.
- Remove spanner and screwdriver. Switch from high to low to ensure settings are correct.
- Switch heater off and remove the manometer tube. Tighten pressure test point by turning the captive screw fully clockwise.
- Replace plastic cap. Ensure the little lug is positioned towards lower right hand side to clear the controls.
- Refit the fascia, making sure not to damage the power cord or switch cable.
- Operate the heater on BOOST, NORMAL and LOW settings. The flame should be stable, no lifting from the burner and the logs should glow after approximately 15 minutes of operation at BOOST setting.

If the flame is unstable:

- Check that the burner is located correctly.
- Check that the glass front is located correctly and is against the sealing rope.
- Check that the gas pressure is correctly adjusted.
- Check that the flue is operating correctly.

If the heater still does not operate to specification refer to the troubleshooting chart on page 18, or contact Sampford IXL in your state.

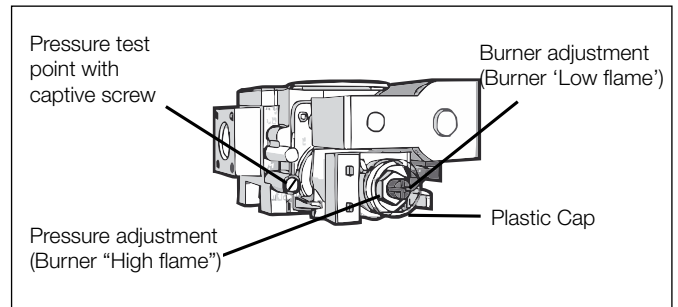

FIG 17

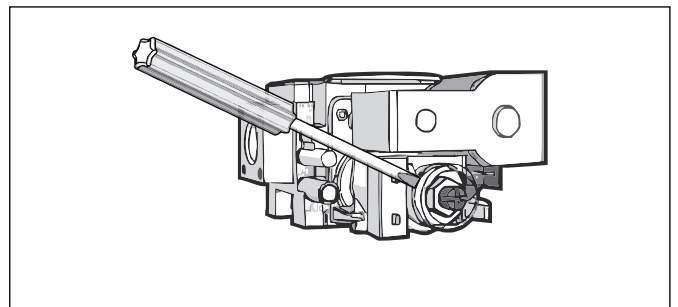

FIG 18

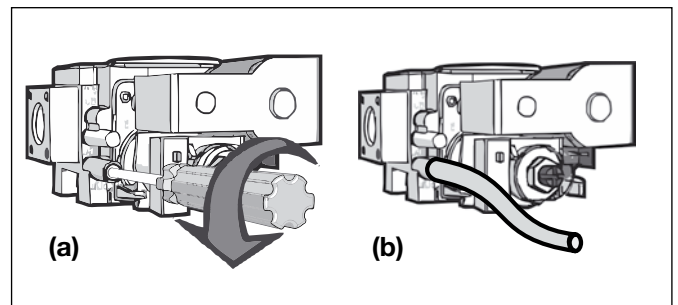

FIG 19

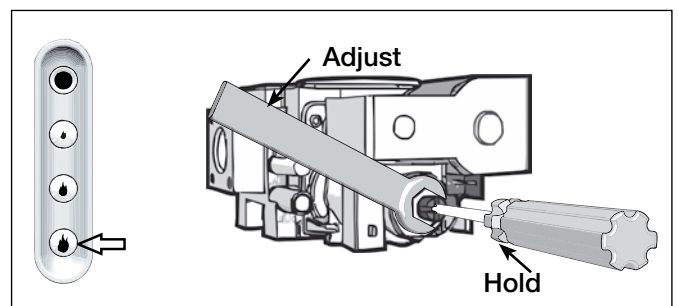

FIG 20

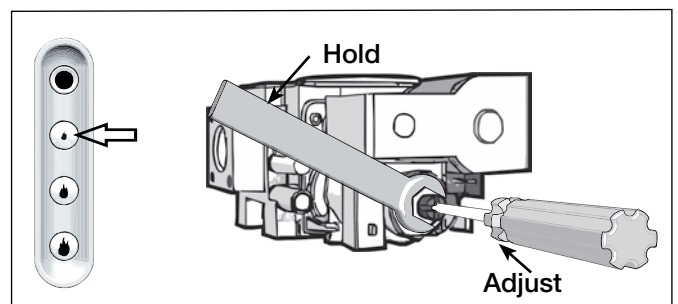

FIG 21

SERVICE INSTRUCTIONS (DO NOT MODIFY THIS APPLIANCE)

General

1. Service work MUST be carried out by an authorised service person only.
2. Unplug from switch socket or turn off power at isolating switch if heater is hard wired.
3. Always shut off the gas supply and ensure that the heater is cool before commencing any service operations.
4. Always check for gas soundness after servicing.

To Replace The Inner Glass

1. Refer page 10, of the installation instructions.
2. Refit glass and replace in reverse order ensuring the inside surface of the glass is clean and free from finger marks.

To Replace The Outer Glass

1. Remove the front glass surround by holding it firmly on either side and pulling it towards yourself.
2. Loosen bottom glass frame and remove top glass frame.
3. Replace glass and refit in reverse order.

Note: ensure the inside surface of the glass is clean and free from finger marks.

To Replace The Gas Valve

1. Remove the lower pedestal front by unscrewing four screws, 2 either side.
2. Unplug the cables from the gas control and disconnect the earth connection.
3. Disconnect the gas inlet (1/2" compression nut) connection at entry gas control and the 16mm nut at the outlet of the gas control.
4. Remove the three M3 screws from the cradle retaining the gas control.
5. Remove gas control valve from heater.
6. Replace gas control in reverse order and check for gas tightness

Note: check the gas pressure on high and low burner settings. Refer 'gas control', page 14.

To Replace The Electronic Controller

1. Unplug both fan and main loom from wiring harness.
2. Remove bracket securing electronic controller in position.
3. Replace electronic controller and refit in reverse order.

To Replace The Ignition Module (Device)

1. Unplug wire connectors from ignition module.
2. Remove module mounting bracket by removing mounting screw.
3. Using pliers bend tabs so that module can come away from the mounting bracket.
4. Replace ignition module and ensure that all wires are reconnected correctly

To Replace The Room Circulation Fan

1. Remove the lower pedestal front by unscrewing four screws 2 either side.
2. Disconnect the fan plug from the plug carrier. Remove the two M5 wing nuts which locate the fan to the fan chamber underside. Lower fan from male thread.
3. Disconnect the silicon tubes from the fan pressure switch, rotate the fan scroll 90° and remove the silicon tubes from the venturi located in the fan scroll. Remove fan from fan chamber.
4. Replacement fan. Remove the venturi and bracket from original fan. Insert and secure the venturi and bracket on replacement fan.
5. Insert fan into fan chamber ensuring that the venturi is not disturbed. Replace silicon tubes onto the venturi and locate fan onto male thread. Secure with M5 wing nuts, ensuring rubber buffer locates over thread. Refer FIG 23.
6. Replace silicon tubes onto fan pressure switch and reconnect fan plug into plug carrier. (Note: Black tube to engage with black nipple on pressure switch)
7. Test operation of room circulation fan and fan pressure switch - turn heater on low burner/fan. The room fan should operate instantaneously and a possible 5 - 10 second delay for the fan pressure switch to energise dependant on room temperature. The burner should also operate on high setting (after the 3 min delay on initial start). If the heater fails to light even when the fan is spinning refer to fault codes on page 18.

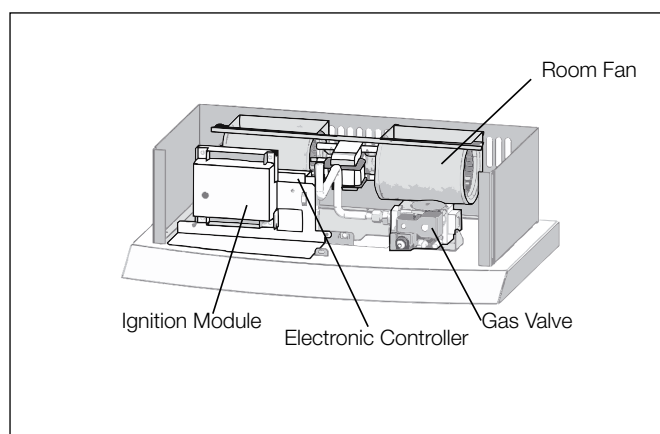

FIG 22

SERVICE INSTRUCTIONS (DO NOT MODIFY THIS APPLIANCE)

To Replace The Fan Pressure Switch

1. Remove the lower pedestal front by unscrewing four screws 2 either side.
2. Remove the screw retaining the bracket mounting the electronic controller. Move the bracket and controls to the front of the heater.
3. Remove the connecting wiring from the pressure switch.
4. Remove the silicon tubes from the pressure switch.
5. The pressure switch is secured onto the rear of the fan chamber housing by two M5 screws. Remove screws.
6. Replace the pressure switch. For wiring, one wire to "C" (common) and the other connect to "NO" (Normally Open). Polarity not important.
7. Re-attach silicone tubes making sure that the black tube attaches to the black side of the pressure switch. Make sure that the tubes are not pinched or kinked.
8. Test operation of fan pressure switch - turn heater on low heat. If heater fails to light even when the fan is spinning refer to fault codes on pages 18 & 19.

To Replace The Burner And Spark/Sense Electrodes

1. Remove the logs from the burner chamber. Refer Page 13.
2. Remove the burner chamber front, 4 screws.
3. Remove 2 M5 wing nuts from under side of burner.
4. Disconnect the 16mm nut at the inlet of the injector.
5. Disconnect the spark and sense electrodes from the ignition module.
6. Lift the burner assembly upward and carefully remove from the burner chamber.
7. Replace in reverse order checking location of spark/sense electrodes, **FIG 24**. Spark gap between electrode and spark plate is 6 - 8mm. Check for gas tightness. Flame sense electrode must be in constant flame. For log placement refer page 13 of this manual.

To Replace The Power Cord

Contact Sampford IXL service department.

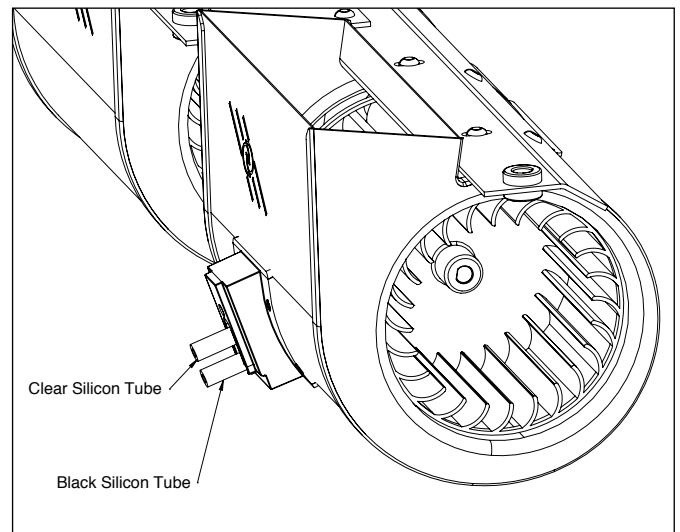

FIG 23 Room Fan

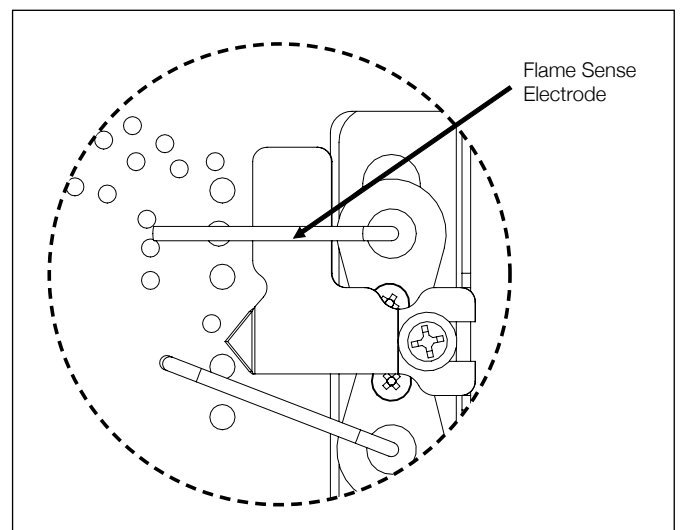

FIG 24

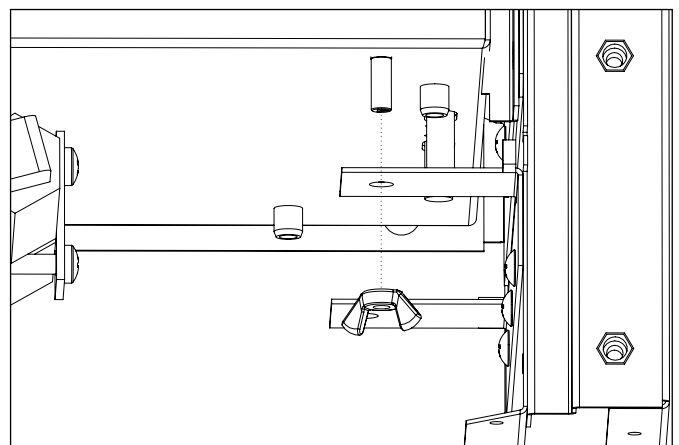

FIG 25 Securing the burner bed

WIRING DIAGRAM

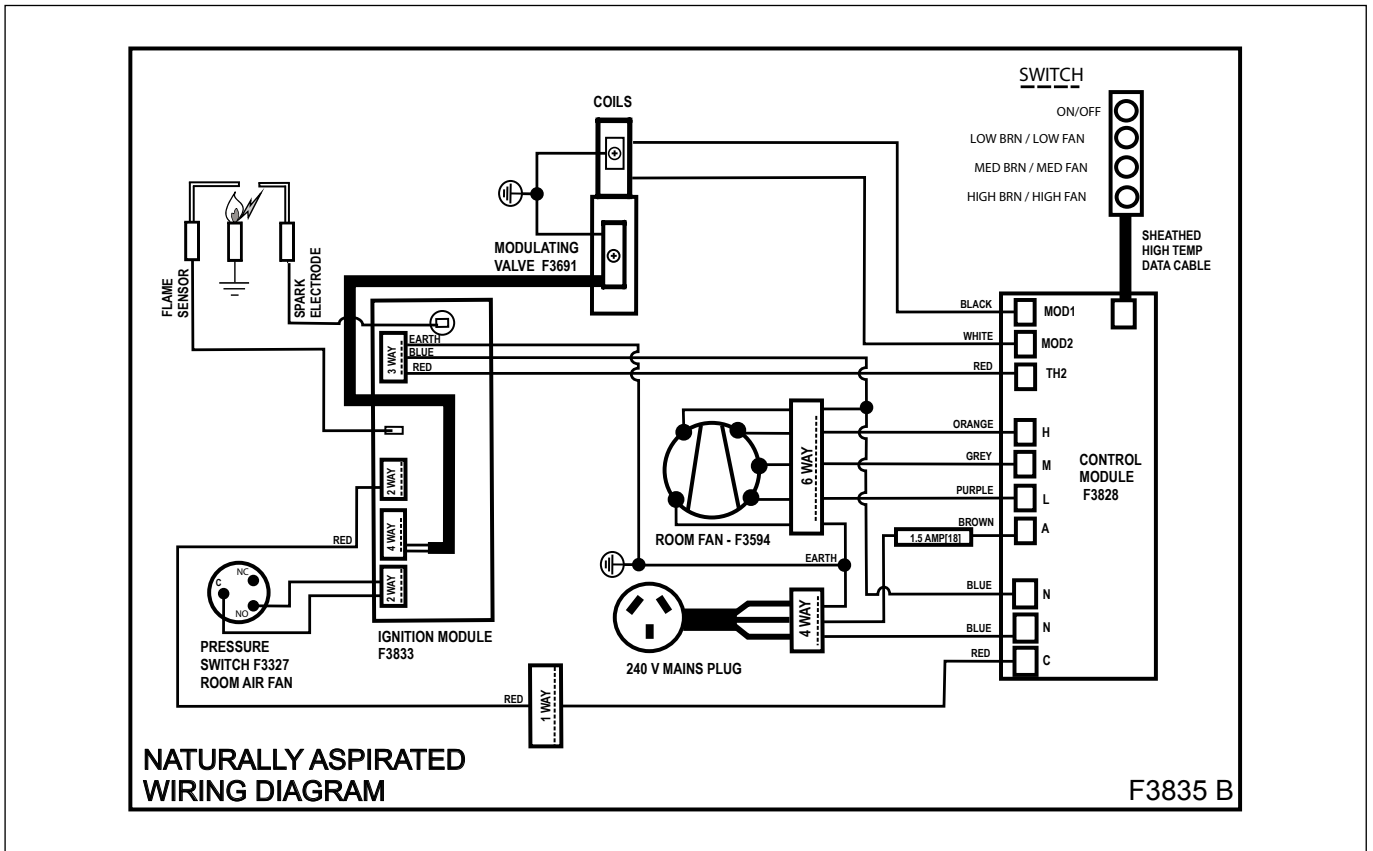

FIG 26

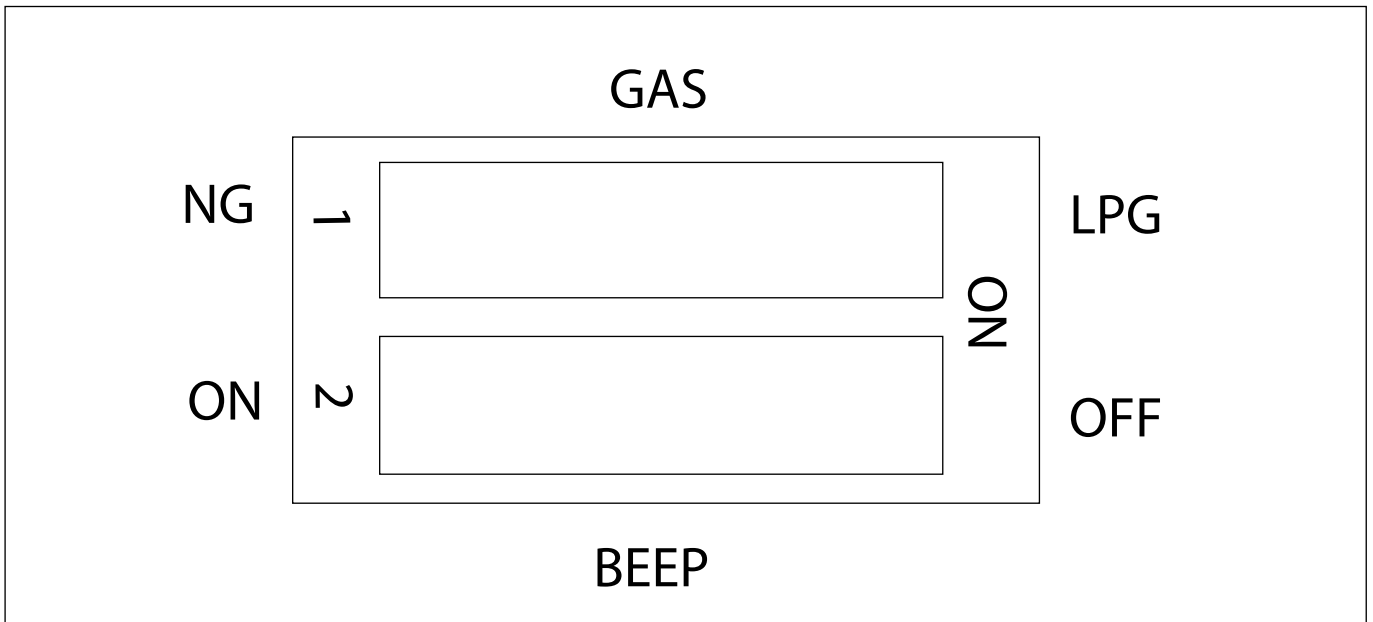

FIG 27 Switch Control Diagram highlighting NG/LP settings & audible beep.

TROUBLESHOOTING

To check the operation of the heaters electrical system you will require a digital multimeter with the functions to measure ac/dc voltage, continuity, resistance and micro-amps.

It is critical that the appliance is earthed and that the active and neutral are not reversed.

Cannon Canterbury Freestanding

There is a green and red LED on the ignition controller. These LEDs act as diagnostic aids when the heater safety systems produce a safe shutdown condition.

Green LED: this is on when the flame is sensed at the flame sensor electrode.

Red LED: this flashes according to the fault code.

No LEDs means there is no power to the ignition module. Check that the heater switch is set to ON by pressing the ON/OFF button. Check the supply voltage. Check the 1.5 Amp fuse, replace if necessary. It is critical that the appliance is earthed and that the active and neutral are not reversed. Do not use an extension cord. This appliance is designed to operate at 240V AC. Substantial voltage dips, or running the unit at voltages substantially lower than 240V AC may cause nuisance shutdowns. If there is still a problem check the power supply plug from the white box with a multimeter (240V AC). If there is no power from this plug when the heater should be on, replace the white box. Remember to re-test the gas pressures any time that the white box is changed. It is recommended that any callout to a customer's home should prompt the checking and resetting of the gas pressures.

Fault Codes

Long	Short	Morse Code	Meaning	Action
1	0	—	Normal operation	
2	1	— — •	Heater has attempted to light, however it did not sense flame within the allowed time.	Check the gas supply to the unit is not switched off. Check the gas pressures. Check the flame and spark electrode connections and that they are positioned correctly. Ensure that the spark is being produced at the spark electrode tip, and is strong (clearly visible and around 6-8mm in length). Adjust if necessary. The burner tray is earthed through contact with the chassis. Check using a multimeter between the earth pin (or earth tab) and the burner tray. If the unit continues to spark after flame is present, ensure that the supply voltage polarity is not reversed.
2	2	— — ••	Flame was established, however the flame electrode has sensed that the flame has become unstable and has shutdown the gas.	Check that the flame sense electrode and the spark plate are correctly positioned. Check the flame sense connections. Check that the flue is correctly constructed. Abnormally strong downdrafts can cause flame instability therefore it is recommended that an appropriate flue cowl is used for windy areas. Improper gas pressures can also cause issues. Check the gas pressures.
1	2	— ••	Room fan (circulation fan) pressure signal not detected.	Check the fan for dust build up and lint. Check that the room air fan is spinning. Check that the pressure tubes are connected correctly and not pinched or kinked. The black tube should run from the black side of the pressure switch to the bottom tapping on the fan venturi. The clear tube should go from the light side of the pressure switch and to the top tapping on the venturi. Make sure that the pressure switch wires are connected correctly. One wire should be to C (Common) and the other should be to NO (Normally Open). If it still doesn't work after checking the above, change the pressure switch.

TROUBLESHOOTING

Fault Codes Continued

Long	Short	Morse Code	Meaning	Action
3	1	— — — •	Room fan (circulation fan) pressure signal has been interrupted.	Check the fan for dust build up and lint. Check that the room air fan is spinning. Check that the pressure tubes are connected correctly and not pinched or kinked. The black tube should run from the black side of the pressure switch to the bottom tapping on the fan venturi. The clear tube should go from the light side of the pressure switch and to the top tapping on the venturi. Make sure that the pressure switch wires are connected correctly. One wire should be to C (Common) and the other should be to NO (Normally Open). If it still doesn't work after checking the above, change the pressure switch.
2	8	— — ••••••••	Room fan (circulation fan) pressure switch has not switched within the expected time.	Check the fan for dust build up and lint. Check that the room air fan is spinning. Check that the pressure tubes are connected correctly and not pinched or kinked. The black tube should run from the black side of the pressure switch to the bottom tapping on the fan venturi. The clear tube should go from the light side of the pressure switch and to the top tapping on the venturi. Make sure that the pressure switch wires are connected correctly. One wire should be to C (Common) and the other should be to NO (Normally Open). If it still doesn't work after checking the above, change the pressure switch.

Other Possible Faults

No gas to burner.	<ul style="list-style-type: none"> • The gas valve should open at the same time as the igniter sparks. If there is no gas to the burner when this occurs check the solenoid coils for continuity. • Check that the gas pressure is present at the test point when the spark is being generated. • Check that there is gas to the inlet of the gas control.
Fuse blowing.	<ul style="list-style-type: none"> • If the fuse continues to blow check the solenoid coils for a signs of them being shorted. • Check the fan and wiring for short circuit.

COPY RATING LABEL HERE

Don't Risk Your Appliance Warranty

Only a licensed person will give you a compliance certificate, showing that the work complies with all the relevant standards. And only a licensed person will have insurance protecting their workmanship for 6 years. So make sure you use a licensed person to install this appliance and ask for your compliance certificate to ensure the manufacturers appliance warranty will be honoured.

Date installed:

Compliance Certificate No:

Installed by:



Gmk 10025
Gmk 10030
AS4553:2008

Part Number:
F3842_B

Sampford IXL

For service to this appliance or spare parts contact the **CANNON** distributor:

Sampford IXL – Spare Parts

Phone: 1300 727 421

Fax: 1300 727 425

Email: aftersaleservice@sampfordixl.com.au