

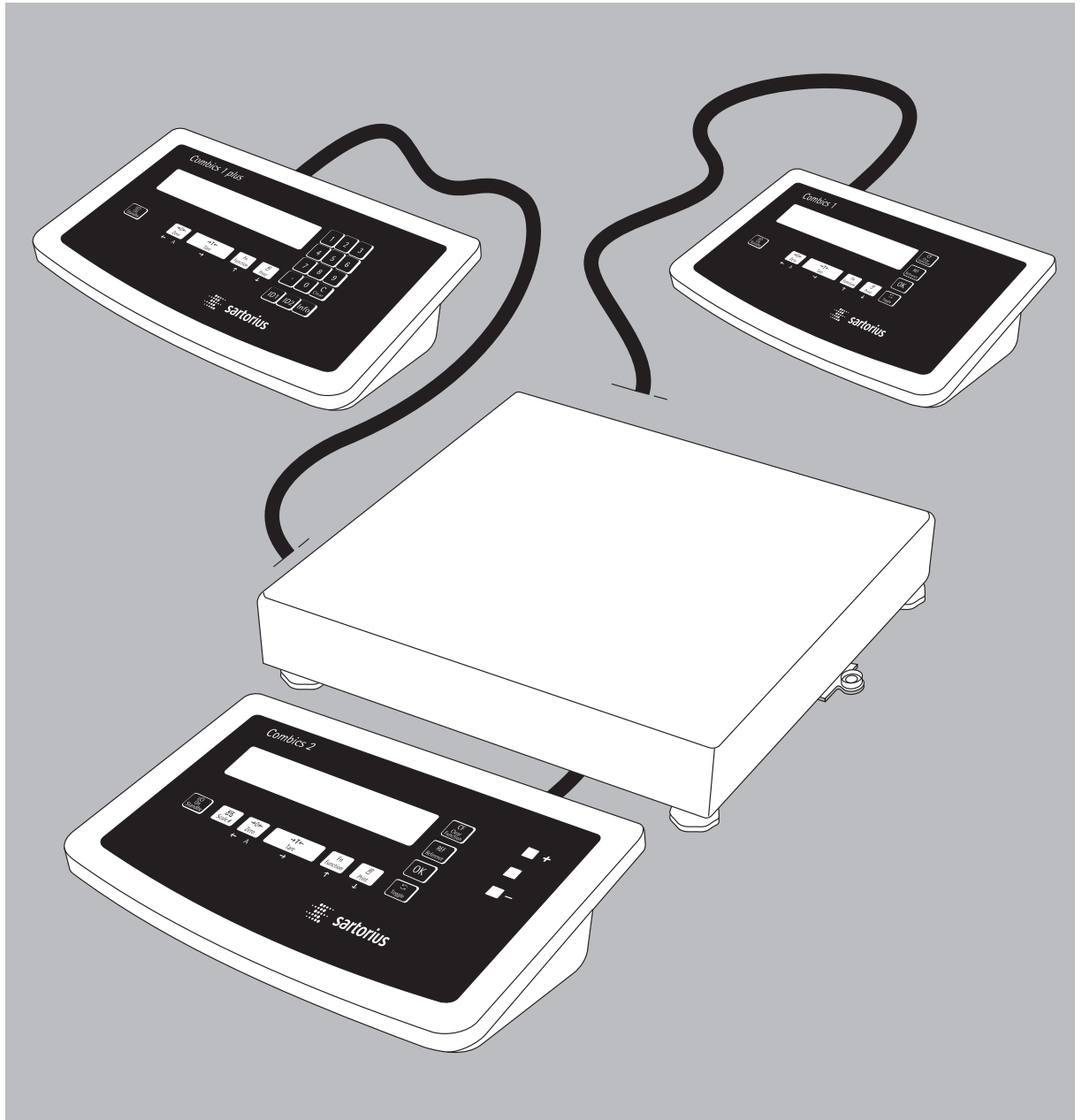

Operating Instructions

Sartorius Combics Complete Scales

Models CH1NE | CH1NG | CW1P | CW1NP | CW1S | CW1FS | CW1NFS | CW1NS | CW2P | CW2S | CW2FS



Intended Use

Combics complete scales are rugged scales with indicators (Combics 1, Combics 1 plus and Combics 2) for the complex quality control tasks you perform every day. They meet the highest requirements placed on the accuracy and reliability of weighing results:

- in the food industry
- in the pharmaceutical industry
- in the chemical industry
- in the electronics and metal-working industries

Combics complete scales are:

- Rugged and durable (stainless steel housing)
- Easy to clean and disinfect
- Easy to operate, thanks to the following features:
 - large, backlit display segments
 - large keys with positive click action
- Independent of the weighing instrument location
- Equipped with a range of interfaces for flexible use
- Password-protected from unauthorized changes in parameters (optional)

Combics 1 plus speeds up your routine procedures with:

- Input functions for tare values through numeric keypad
- Option for 2 alphanumeric lines to identify samples
- Connectivity for bar code scanner to enter tare values or ID codes

Combics 2 indicators have the following features:

- Built-in application programs:
 - Counting
 - Neutral measurement
 - Weighing in percent
 - Averaging
 - Checkweighing
 - Classification
 - Net-total formulation
 - Totalizing
- Automatic initialization when you switch on the Combics
- Automatic taring when a load is placed on the weighing instrument
- Optional remote control using an external computer

Symbols

The following symbols are used in these instructions:

- indicates required steps
- describes what happens after you have performed a certain step
- ⚠ indicates a hazard

Hotline:

For advice on the use of these applications, just call or fax your local Sartorius office. For the address, please visit our Internet website at: www.sartorius.com

Contents

Page		Page	
2	Intended Use	79	Data Interfaces
4	Warnings and Safety Precautions	81	Pin Assignment Charts
5	General View of the Equipment	83	Installing the Interface Cable
6	Getting Started	84	Cabling Diagram
12	Operating Design	85	Synchronization
12	Weighing/Measurement	86	Configuring the Data Interface as a COM Port
14	Configuration (Operating Menu)	86	Data Input Format
15	Operation	87	Data Output Format
15	Weighing $\Delta\Delta$	89	Configuring the Data Interface as a Printer Port
23	Individual ID Codes	89	Configuring Printouts
25	Calibration and Adjustment	91	Sample Printouts
27	Counting \clubsuit	94	Error Codes
31	Neutral Measurement \clubsuit $\pi\pi$	95	Care and Maintenance
35	Checkweighing ∇	95	Repairs
40	Classification ∇ \square	95	Cleaning
45	Weighing in Percent %	95	Safety Inspection
49	Averaging (Animal Weighing) \boxtimes	96	Recycling
52	Net-total Formulation \downarrow	97	Overview
55	Totalizing Σ	97	Common Specifications
59	Configuration	97	Model-specific Specifications
59	Operating Menu Overview	98	Type Designation
60	Setting the Language (Example)	101	Dimensions (Scale Drawings)
61	Entering/Changing the Password (Example)	103	Accessories
63	Operating Menu Overview (Parameters)	107	Declaration of Conformity
		109	EC Type-approval Certificate
		111	Plates and Markings
		119	Index
			Appendix:
			General Password

Warning and Safety Precautions

Safety Information:

- Please read these operating instructions carefully before using your scale to prevent damage to the equipment.
- ⚠ Do not use this equipment in hazardous areas.
- ⚠ Use only standard cables that have protective grounding conductors. The protective conductor must not be disconnected for any reason.
- ⚠ Disconnect the scale from power before connecting or disconnecting peripheral devices.
- ⚠ The scale may be opened only by trained service technicians.
- ⚠ If you operate the equipment under ambient conditions subject to higher safety standards, you must comply with the applicable installation regulations.
- ⚠ If there is visible damage to the equipment or power cord, unplug the equipment and make sure it cannot be used for the time being.
- ⚠ If you use electrical equipment in installations and under ambient conditions requiring higher safety standards, you must comply with the provisions as specified in the applicable regulations for installation in your country.

Installation:

- Proceed with extreme caution when using pre-wired RS-232 connecting cables from other manufacturers, as the pin assignments may not be compatible with Sartorius equipment. Check all pin assignments against the cabling diagrams and disconnect any lines that are not assigned.
- ⚠ Always wear gloves, safety boots and protective clothing when lifting the load plate with a vacuum lifting pad. Danger of injury! This work may be carried out only by authorized and properly trained personnel.
- Weighing platforms with dimensions larger than 1 x 1 m are provided with suspension supports. Be careful not to stand under the load when the weighing platform/load plate is being transported or lifted with a crane. Always comply with the applicable accident prevention regulations. Make sure to avoid damaging the terminal box and housing or the load cell during transport.
- Connect only Sartorius accessories and options, as these are optimally designed for use with your Combics indicator. The operator shall be solely responsible for installation and testing of any modifications to Sartorius equipment, including connection of cables or equipment not supplied by Sartorius. Contact Sartorius for detailed operating specifications in accordance with the Standards for immunity to interference.
- Do not expose the indicator to aggressive chemical vapors or to extreme temperatures, moisture, shocks, or vibration.
- Clean your Combics only in accordance with the cleaning instructions (see “Care and Maintenance”).
- If you have any problems with your Combics indicator, contact your local Sartorius customer service center.

IP Rating:

- CW1P | CW1NP | CW2P | CH1NE models are rated to IP44 (with option L1: IP65);
- CW1(F)S | CW1N(F)S | CH1NG | CW2(F)S models are rated to IP67.
- The IP65/IP67 protection rating is ensured only if the rubber gasket is installed and all connections are fastened securely (including the caps on unused sockets). Weighing instruments must be installed and tested by a certified technician.
- If you install an interface port after setting up your indicator, keep the protective cap in a safe place for future use. The cap protects the interface connector from vapors, moisture and dust or dirt.

Using the Equipment in Legal Metrology in the EU*:

- When the indicator is connected to a weighing instrument and the resulting weighing instrument is to be verified, make sure to observe the applicable regulations regarding verification. When connecting a Sartorius weighing instrument, please observe the “Guide to Verification” on the enclosed CD and the permitted weighing range as listed in the Declaration of Conformity.
- EU legislation requires that a control seal be affixed to the verified device. The control seal consists of a sticker with the “Sartorius” logo. This seal will be irreparably damaged if you attempt to remove it. If any of the verification seals are damaged, make sure to observe the national regulations and standards applicable in your country in such cases. In some countries, the verification will become null and void and the equipment must be re-verified.

* Including the Signatories of the Agreement on the European Economic Area

General View of the Equipment

Combics 1 | Combics 1 plus

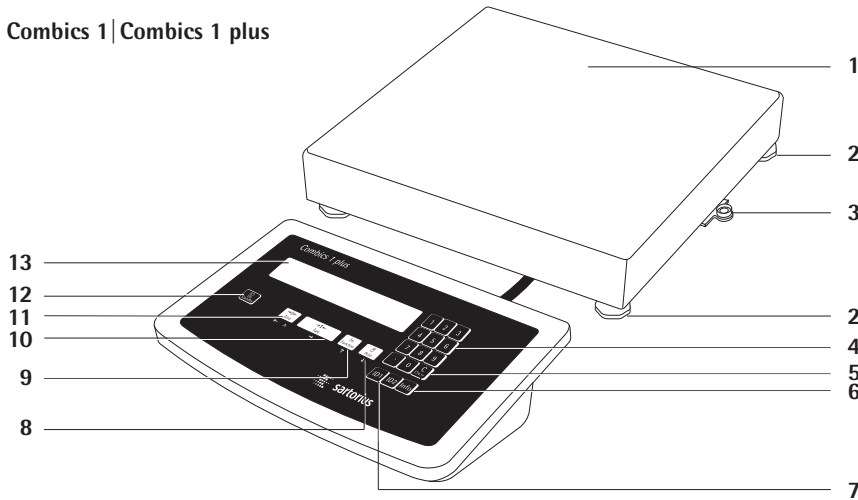

Combics 2

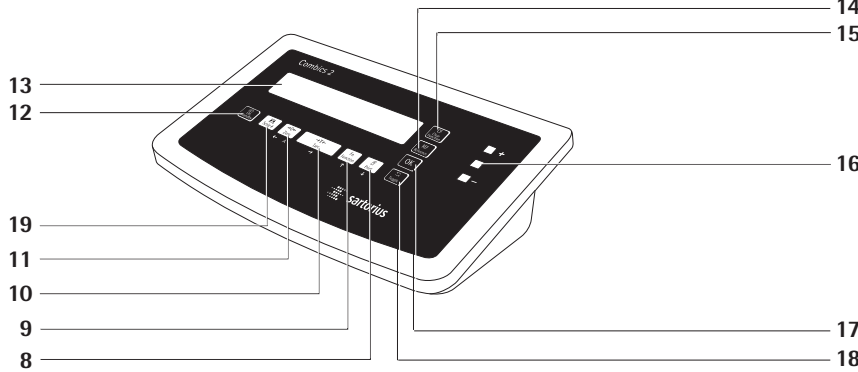

Rear view: Model: CW1P | CW1NP | CW2P

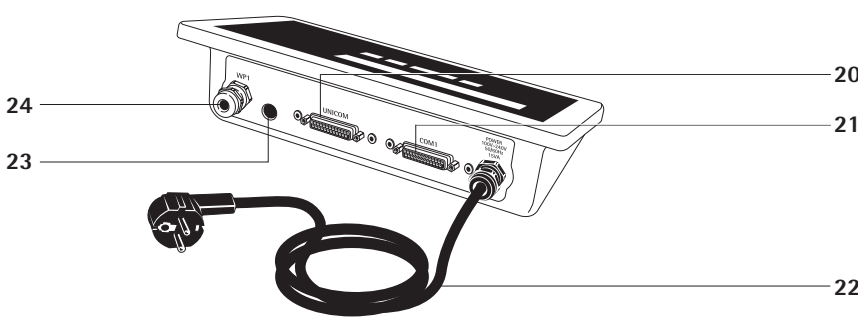

Rear view: Model: CW1S | CW1NS | CW2S | CW1FS | CW1NFS | CW2FS | CH1NE | CH1NG

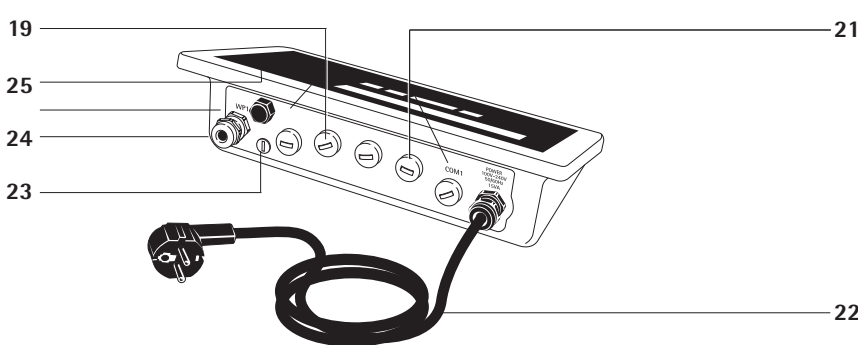

Display and Keypad:

- 1 Load plate
 - 2 Leveling feet
 - 3 Level indicator
 - 4* Keypad for numeric input
 - 5* "Clear" key (deletes ID codes and tare input)
 - 6* "Info" key (shows ID codes and tare input)
 - 7* ID keys (for entering ID codes)
 - 8 Data output
 - 9 Gross/net; 2nd unit or 10 x higher resolution (depending on the settings)
 - 10 Tare
 - 11 Zero
 - 12 On/off key
 - 13 Display (for a detailed view, see chapter entitled "Operating Design")
 - 14 Select reference weight (depending on the application)
 - 15 "Clear" key
 - 16 LEDs (for checkweighing and classification)
 - 17 Start application
 - 18 Toggle to the application program | application-specific information
 - 19 Toggle to different weighing platform
- * Combics 1 plus only

Rear View

- 20 Second "UNICOM" interface port for bar code scanner or external rechargeable battery pack (Combics 2 only) (additional functions optional)
- 21 RS-232C "COM1" interface port (standard)
- 22 Power cord with country-specific plug
- 23 Menu access switch (standard operating mode or legal metrology mode)
- 24 Connector for weighing platform
- 25 Vent valve

Getting Started

The complete scale is available in various versions. If you have ordered special options, the indicator will be supplied with these options premounted at the factory.

Storage and Shipping Conditions

- Allowable storage temperature: -10 ...+40°C (+14°F ... + 104°F)
- Unpackaged equipment may lose its accuracy when exposed to strong vibration. Excessive vibration may compromise the safety of the equipment.
- Do not expose the indicator unnecessarily to extreme temperatures, moisture, shocks, or vibration.

Unpacking

- After unpacking the equipment, please check it immediately for any visible damage.
- If you detect any damage, proceed as directed in the chapter entitled "Care and Maintenance" under "Safety Inspection."
- If you will need to ship the equipment later, save all parts of the packaging because only the original packaging provides the best protection for shipment.
- Before shipping, be sure to disconnect all cables to prevent damage.

Equipment Supplied

- Indicator
- Weighing platform
- Operating instructions (this manual)
- Special accessories listed on the bill of delivery, if ordered

Installation Instructions

Choose a location that is not subject to the following unfavorable conditions:

- Excessive temperatures (operating temperature range: -10°C to +40°C; +14°F to +104°F)
- Aggressive chemical vapors
- Excessive moisture (depends on IP rating)

Conditioning the Indicator

Moisture in the air can condense on cold surfaces whenever the equipment is moved to a substantially warmer place. To avoid the effects of condensation, condition the indicator for about 2 hours at room temperature, leaving it unplugged from AC power.

Checking the Geographical Data Entered for Use in Legal Metrology

Preparation

(see also the "Device Information" menu items listed under "Operating Menu Overview" in the chapter entitled "Configuration".)

- Press I/O to turn on the Combics
- While all segments are lit, press ←T←
 - > *APPL* is displayed
- Select "Info": Press Fn repeatedly; press ←T← to confirm
- Select "Device Specific Information":
 - for WP1 or WP2: Press Fn repeatedly; press ←T← to confirm
 - > Press Fn repeatedly to scroll through the geographical data (data shown depends on input before verification), for example:
 - Latitude (in degrees): 5 1 4
 - Elevation (in meters): 5 13 5
 - or
 - Acceleration of gravity in m/s^{-2} : 9.8 10 5

The scale can be used anywhere in Germany if the geographical data is as follows:

- Latitude: 51.00 degrees
 - Elevation: 513 meters
- This data corresponds to the following value:
Acceleration of gravity: 9.810 m/s^{-2}

These values are calculated for Germany based on a mean value for the Earth's acceleration. The greater the precision of the geographical data entered, the greater the precision achieved with the weighing instrument; the tolerance range, however, is also restricted accordingly.

The tolerance ranges, for example for a scale with 3000 e, are as follows:

- $\pm 100 \text{ km}$ for the latitude and
- $\pm 200 \text{ m}$ for the elevation above sea level.

⚠ If used outside the specified zone, the scale must be re-verified for use in legal metrology. Please contact an authorized service technician.

Seal on Indicators Verified for Use in Legal Metrology in the EU*:

EU legislation requires that a control seal be affixed to the verified device. The control seal consists of a sticker with the "Sartorius" logo. This seal will be irreparably damaged if you attempt to remove it. If the seal is broken, the validity of the version becomes null and void, and you must have your scale re-verified.

* Including the Signatories of the Agreement on the European Economic Area

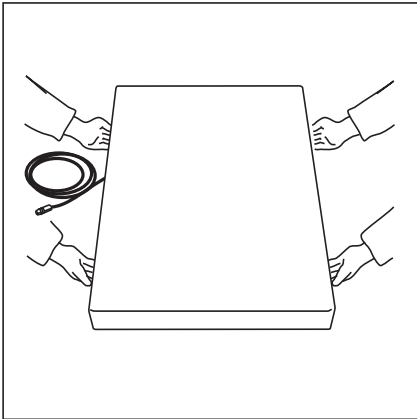

Unpacking the Platform

Important note:

These instructions apply to platforms that are 60 x 80 cm and larger.

- Remove the weighing platform and weighing pan from the packaging.
- When transporting or lifting the device, hold the unit on the longer sides and observe the safety precautions (wear safety shoes and gloves if necessary).
- Remove any plastic wrapping, packaging strips and styrofoam.

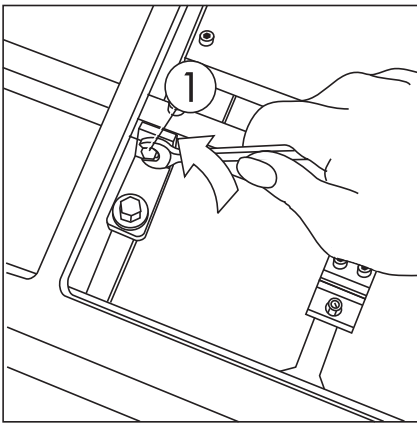

Removing the Transport Locking Device

- Bring the scale to the location where it will be used and remove the weighing pan.
- Loosen the transport locking device by removing screw 1.

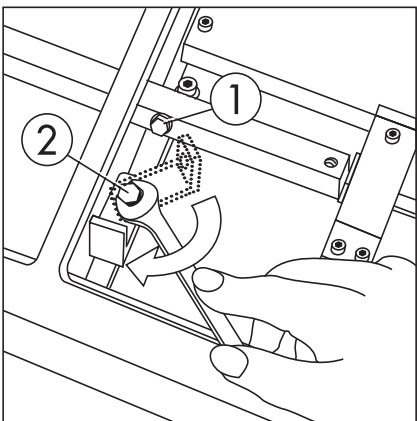

- Loosen screw 2, turn the fastening bracket by 180° and then tighten screw 2.
- Tighten screw 1 again at the lever.

Important Note Regarding Transport of the Weighing Platform

⚠ Be sure to refasten the transport locking device before transporting the weighing platform.

Level the weighing platform at the weighing location using the adjustable feet so that the air bubble is centered in the level indicator circle. Check that all four adjustable feet are in contact with the surface.

The load must be equally distributed over all four leveling feet.

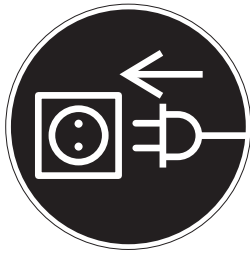

Connecting the Equipment to AC Power

- Check the voltage rating and the plug design.
- The scale is powered through the pre-installed power cord. The power supply is built into the scale, which can be operated with a supply voltage of 100V to 240V. Make sure that the voltage rating printed on the manufacturer's ID label is identical to that of your local line voltage. If the voltage specified on the label or the plug design of the AC adapter does not match the rating or standard you use, please contact your Sartorius office or dealer.
The power connection must be made in accordance with the regulations applicable in your country.
- To power a protective class 1 device, plug the power cord into an electrical outlet (mains supply) that is properly installed with a protective grounding conductor (protective earth = PE).

Safety Precautions

If your local AC output does not have a protective grounding conductor (protective earth), have a certified electrician install equivalent protection according to your country's valid installation requirements. Make sure the protective grounding effect is not neutralized by use of an extension cord that lacks a protective grounding conductor.

Connecting Electronic Peripheral Devices

- Make absolutely sure to unplug the device from AC power before you connect or disconnect a peripheral device (printer or PC) to or from the interface port.

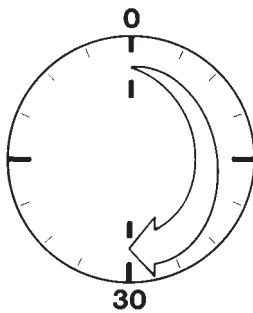

Warmup Time

To deliver exact results, the device must warm up for at least 30 minutes after initial connection to AC power or after a relatively long power outage. Only after this time will the device have reached the required operating temperature.

Using Equipment Verified as Legal Measuring Instruments in the EU*:

- Make sure to allow the equipment to warm up for at least 24 hours after initial connection to AC power or after a relatively long power outage.

Connecting the External Rechargeable Battery Pack (Accessory: YRB10Z)

- △ Disconnect the equipment from AC power (unplug the AC adapter)

- Installation
For model CW1P | CW1NP | CW2P: Connect a 25-pin D-SUB male connector (connecting cable YCC02-RB01) to a second "UNICOM" interface port
For model CW1(F)S | CW1N(F)S | CW2(F)S: see the section "Pin Assignment Chart" (via connecting cable YCC02-RB02 or as option L2)

Operating

- Hours of operation: up to 40, depending on the weighing platform connected; without options. The Combics will automatically switch to battery operation whenever there is a power shortage or the power is cut off. Once the mains power supply is reinstated, the Combics will automatically switch back to normal operation.

Battery symbol

Battery fully charged:

Battery empty:

* including the Signatories of the Agreement on the European Economic Area

Connecting a Bar Code Scanner (Accessory: YBR02CISL)

⚠ Disconnect the equipment from AC power (unplug the AC adapter)

○ Installation

For model CW1NP | CW2P:

- Connect a 25-pin D-SUB male connector (connecting cable YCC02-BR01) to a second "UNICOM" interface port
- For bar code scanner and external rechargeable battery: please use T connector YTC01.

For model CW1N(F)S | CW2(F)S: see the section entitled "Pin Assignment Chart" (via connecting cable YCC02-RB02 or as option M8)

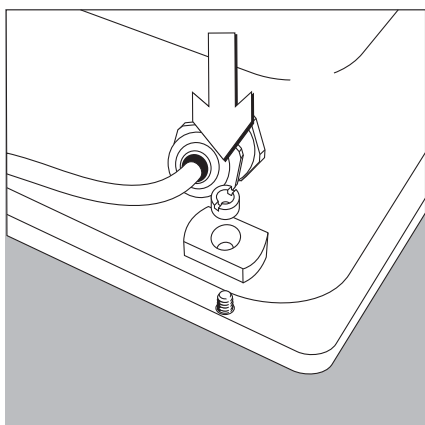

Installing the Verification Adapter for Use in Legal Metrology (on verifiable models only)

- Remove the nut located on the back of the indicator
- Use the slotted screw to install the adapter plate

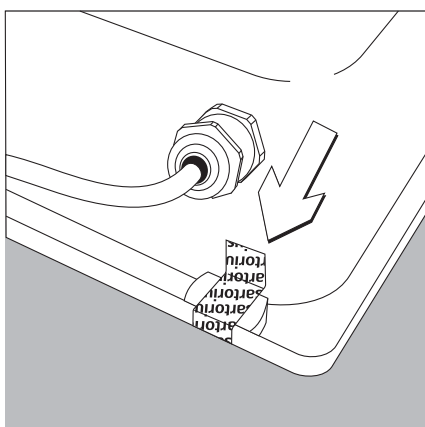

- Affix the verification seal over the adapter

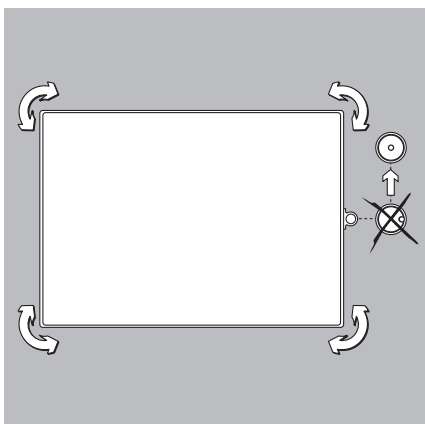

Leveling the Weighing Platform

Purpose:

- To compensate for uneven areas at the place of installation
 - Make sure that the equipment is placed in a perfectly horizontal position for consistently reproducible weighing results
- Always re-level the weighing platform after changing the place of installation.

- Remove the weighing pan.
- Level the weighing platform using the four adjustable feet. Keep turning the feet until the air bubble is centered in the level indicator circle.

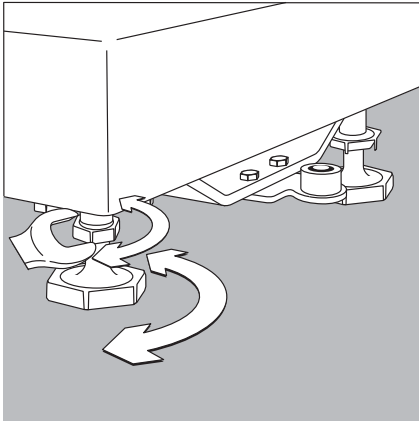

- Loosen the lock nuts on the leveling feet using an SW17 wrench.
- Use an SW5 Allen wrench to extend or retract the leveling feet.
 - > Setting the adjustable feet:
 Raise the weighing platform by extending the leveling feet (turning clockwise).
 Lower the weighing platform by retracting the leveling feet (turning counterclockwise).

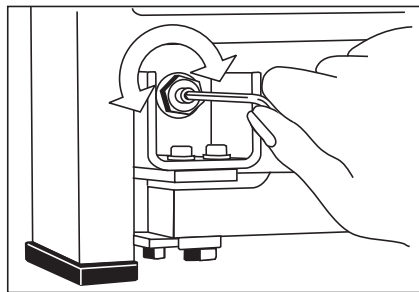

- After aligning the weighing platform, tighten the lock nuts against the platform frame.
 - > Small platforms (1 weighing cell): against the platform frame,
 large platforms (4 weighing cells): against the platform foot.
- Make sure that all the leveling feet are touching the surface.
 The load must be equally distributed over all the leveling feet.
- Once you have leveled the weighing platform, tighten the lock nuts.
- Place the weighing pan back onto the weighing platform.

Operating Tolerances

Never exceed the maximum capacity of the weighing platforms. The maximum loading capacities of the weighing platforms are listed in the table below and depend on the position of the weight loaded on the platform (center, sides, one-sided corner load):

Platform dimensions	Center	Side	Corner
320 x 240	50	35	20
400 x 300	130	85	45
500 x 400	300	200	100
500 x 400 (P*)	600	400	200
650 x 500 (S**)	450	300	150
800 x 600 (P*)	1,200	800	400
800 x 600 (S**)	900	600	300
800 x 800	4,500	3,000	1,500
1000 x 800	4,500	3,000	1,500
1000 x 1000	4,500	3,000	1,500
1250 x 1000	4,500	3,000	1,500
1500 x 1250	4,500	3,000	1,500
1500 x 1500	4,500	3,000	1,500
2000 x 1500	4,500	3,000	1,500

* Steel

** Stainless steel

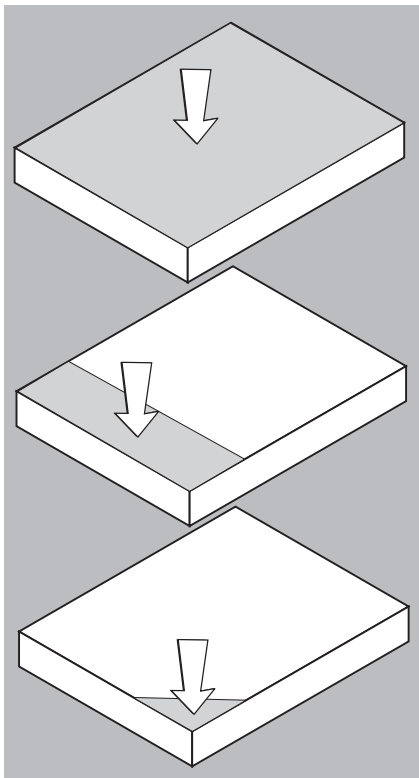

For CH*E models:

Platform dimensions 300 x 400	Loading capacity (center) in kg 130
----------------------------------	--

For CH*G models:

Platform dimensions 300 x 400	Loading capacity (center) in kg 130
----------------------------------	--

Platform dimensions 800 x 600	Loading capacity (center) in kg 600
----------------------------------	--

Shock Resistance

The weighing platform features a rugged construction, but you should not allow objects to fall onto the weighing pan. Also avoid bumps to the side of the unit and shocks. The weighing platform withstands the loads specified in standard DIN 1EC68, Part 2-27.

Important Note About Planning Structures for Attachment to the Weighing Platform

The weighing platform is suitable for installation in systems. The scale drawings should be used as the basis for selecting any necessary structures to be affixed to the platform. Use the YAS041S fastening set to secure the weighing platform.

Moving or rotating parts on the weighing pan must be designed so that they do not influence the weighing results. For example, rotating parts must be balanced. The weighing pan must have clearance on all sides to prevent any falling objects or dirt from creating a connection between the weighing platform and any permanent structures.

Cables and hoses between the weighing platform and other devices must not exert any force on the weighing platform. These cables must not touch the weighing pan.

When setting up systems in hazardous areas (zone 2 or 22), be sure to observe and comply with the relevant regulations (e.g., EN60079-14).

Pay special attention that electrostatic charges resulting from moving parts (e.g., conveyors) are avoided or discharged.

Preload Range (Zero-Point Range)

The weight of any structures that are permanently mounted on the weighing platform constitutes the "preload." The preload is electronically compensated in the weighing platform so that the entire weighing range is available and so that the scale can be zeroed or calibrated (using external weights).

Larger preloads will lead to a reduction of the weighing range. The weight on the scale may not fall below the following weighing range values:

- At least 30 kg of the weighing range must remain for models CH*G-150 1G-H
- At least 60 kg of the weighing range must remain for models CH*G-300 1G-H

⚠ You must always set the preload prior to verifying the scale for legal metrology.

All structures must be mounted on the weighing platform before it is connected to AC power.

Operating Design

Keys

The operation of Combics 1, Combics 1 plus and Combics 2 involves just a few keys. These keys have one function during measurement and another during configuration. Some of the keys have one function when pressed briefly, and another when held for longer than 2 seconds.

If a key is inactive, this is indicated as follows when it is pressed:

- The error code "-----" is displayed for 2 seconds. The display then returns to the previous screen content.
- An acoustic signal (double-beep) is emitted.

Weighing/Measurement

Input Through the Keypad

Keys below the Display

 On/off key
(in standby mode, αFF is displayed).

 - Press briefly:
Zero the instrument
- Press and hold (> 2 sec):
Show the adjustment/
configuration counter

 - Tare the instrument
- Save numeric input as tare weight
(Combics 1 plus only)
- Press and hold (> 2 sec):
Start calibration/adjustment







 Toggle the display between
(depends on configuration):
- first and second weight unit,
- gross and net values, or
- normal and 10-fold increased
display resolution



 - Press briefly: Print
- Press and hold (> 2 sec):
Print GMP footer



 When two weighing instruments
are connected, this key toggles the
display between instruments
(Combics 2 only).



Keys to the Right of the Display on Combics 1 plus

Keys for entering ID codes and tare values

, , ... , 
Numeric keypad for entering
values that are identified by the key
subsequently pressed (e.g.,  for
tare input or "ID" key for ID codes)

 Press to delete data (either ID code
or tare input, depending on subse-
quent key; e.g.,  for tare)
When pressed during numeric input:
deletes the last character entered

 Press to enter data (either ID code
or tare value, depending on sub-
sequent key; e.g.,  for tare)

, 
Press to store or view ID codes
(user-defined data to identify
weight values)

Keys to the Right of the Display on Combics 2

These keys are used for operating
applications. Please refer to the individ-
ual application descriptions for details.

 Deletes initialization values or
totalizing memory, depending on
configuration.







 For modifying reference values.

 Store a value or start an
application program.

 Toggle between display modes
within an application program

Input Through the Digital Input Port

The indicator is equipped with a control
input (universal input port). You can
connect a hand switch or foot switch
to this port, if desired. Assign one
of the following functions to this port
in the operating menu:

-  key
-  (> 2 sec.)
-  key
-  key (> 2 sec.)
-  key
-  key
-  key

Operating Design

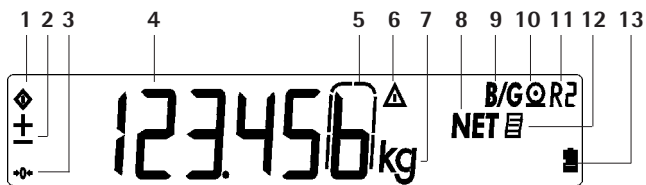

Display during weighing/measurement
(Combics 1, Combics 1 plus) (example)

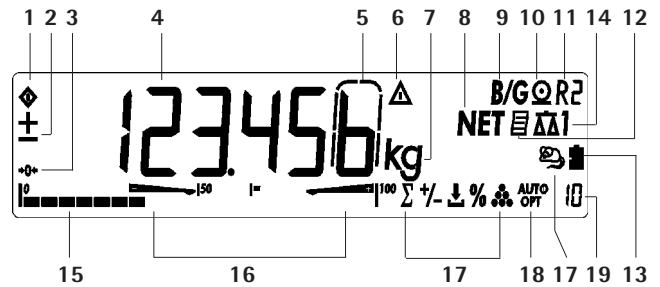

Display during weighing/measurement
(Combics 2) (example)

Display in Weighing Mode

The illustration above shows all of the main display elements and symbols shown during weighing.

- 1 Busy symbol; indicates that an internal process is in progress
- 2 ± sign for the value displayed
- 3 Identifies “zero” as a weight value (after the weighing instrument has been zeroed)
- 4 Weight value or calculated value (main display)
- 5 In legal metrology, on equipment with $e = d$, the digit shown with a border is not valid
- 6 Identification of calculated value in the main display (value not valid in legal metrology)
- 7 Weight unit of the value displayed
- 8 Net value in the main display (when data is stored in tare memory)
- 9 Gross value in main display (when data is stored in tare memory)
- 10 Printing in progress
- 11 Display of the range on multiple-range instruments
- 12 GMP-compliant printing in progress (Combics 1 plus and Combics 2 only)
- 13 Battery symbol showing status of rechargeable battery (empty outline indicates battery is drained)

- 14 Indicates active weighing instrument; flashes to prompt calibration/adjustment (Combics 2 only)
- 15 Bar graph (Combics 2 only)
 - Shows how much of the available weighing capacity is “used up” by the current load, or
 - Shows the measured value in relation to a target value (with the Checkweighing or Classification application)
- 16 Symbols for Checkweighing and classification (Combics 2 only)
- 17 Application symbols: Totalizing, Checkweighing, Classification, Net-total Formulation, Weighing in Percent, Counting and Neutral Measurement. For details, please refer to the the descriptions of the applications (Combics 2 only).
- 18 Symbols for reference updating (Combics 2 only)
 - Auto: Depending on the weight value, a reaction is triggered in the application
 - Opt: Automatic reference updating has been performed (Counting application)
- 19 Numeric display; e.g., shows reference value (Combics 2 only)

Saving Data in Weighing Mode

- All of the application parameters saved (e.g., reference values) remain stored and are still available when
- you switch the Combics off and then back on again
 - you return to the originally selected application from a second one (for example, when you switch from Averaging back to Counting, all parameters saved for Counting are available)

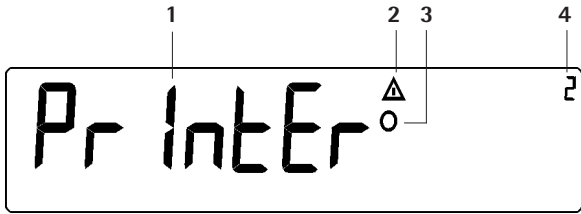

Display of menu settings: Text menu (example)

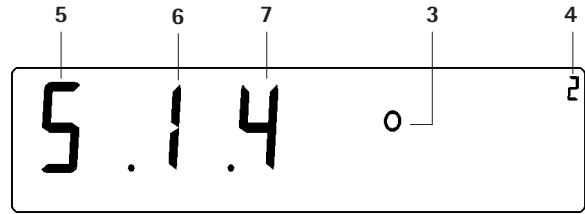

Display of menu settings: Numeric menu (example)

Configuration (Operating Menu)

Navigation and input in the operating menu are implemented using the keys below the display (on Combics 1 plus, numeric values can be entered using the numeric keypad)

Opening the Menu

Press the key to switch the Combics off and then on again; while all segments are displayed, press the key briefly.

Navigating the Menu

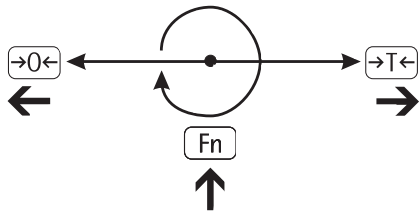

- Close the active submenu and return to next higher menu level ("back")

- Press briefly (< 2 sec):
Select and store a menu item
- Press and hold (> 2 sec):
Exit the menu

- Show the next item on the same menu level (the display scrolls through all items in series)

- Print the menu settings starting from the current position, or print Info data

Alphanumeric Input in the Menu

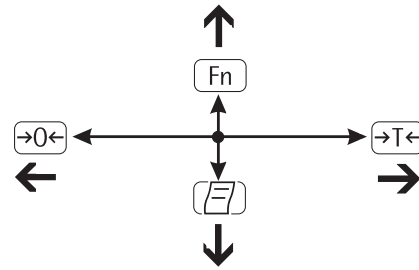

- Press briefly:
Activate character to the left of the current character (when first character is active: exit input mode without saving changes)
- Press and hold (> 2 sec):
Exit the input mode without saving changes

- Press briefly (< 2 sec):
Confirm currently active character and move 1 position to the right (after the last character: store input)
- Press and hold (> 2 sec):
Store current input and display the menu item

- Cursor in first position, no characters entered yet: Delete character(s) and enter 0
- Change the displayed character; scroll forward (sequence: 0 to 9, decimal point, minus sign, Z to A, space)

- Cursor in first position, no characters entered yet: Delete entire string and enter a space
- Change the displayed character; scroll backwards (sequence: Space, A to Z, minus sign, decimal point, 9 to 0)

Numeric input in Combics 1 plus operating menu:

Enter values (date and time, etc.) using the 10-key numeric keypad

Display of Menu Settings

The illustration above shows all of the main display elements and symbols shown during menu configuration.

- 1 Selected menu item on text level (e.g., "Printer" for configuring the connected printer)
- 2 Indication that there are additional submenus
- 3 Indication that this is the currently active setting
- 4 Menu history (indicates the highest menu level)
- 5 Highest level in numeric menu
- 6 Second level in numeric menu
- 7 Third level in numeric menu

Saving Data in Configuration Mode

The parameters selected in the operating menu remain stored after you switch off the Combics.

You can prevent unauthorized changes in operating menu settings by requiring password input for menu access.

Operation

Weighing Δ

The basic weighing function is available at all times.

Features:

- Zero the weighing instrument by pressing $\rightarrow 0 \leftarrow$
- Store the weight on the instrument as tare by pressing $\rightarrow T \leftarrow$
- Tare container weight automatically
- Enter tare weight through bar code scanner (Combics 1 plus and Combics 2 only)
- Enter tare weight through numeric keypad (Combics 1 plus only)
- Delete tare values by pressing $\square 0$ and $\rightarrow T \leftarrow$ or $\square C$ and $\rightarrow T \leftarrow$ (Combics 1 plus only)
- Press $\square Fn$ to toggle the display between:
 - Gross and net values,
 - 1st and 2nd weight unit, or
 - normal and 10-fold higher resolution
- Weighing with two weighing instruments (Combics 2 only)
- Individual data ID codes with numeric values for identifying weight values (Combics 1 plus only)
- Print weight value:
 - GMP-compliant printout
 - Automatic printing
 - Automatic data output (see "Data Interfaces")

Automatic Taring (Menu Item 3.7)

When menu item 3.7.2 is active, the first load placed on the weighing instrument that exceeds the specified minimum load is stored, at stability, in the tare memory.

The weighing instrument returns to the initial state when the load is less than 50% of the minimum load.

Minimum Load for Automatic Taring and Automatic Printing (Menu Item 3.5)

You can choose from the following settings for the minimum load:

- 1 digit (no minimum load)
- 2 digits
- 5 digits
- 10 digits
- 20 digits
- 50 digits
- 100 digits
- 200 digits
- 500 digits
- 1000 digits

The "digits" here refer to the intervals in the connected weighing instrument. If the interval of the connected instrument is 1 g, for example, and 1000 digits are required, the minimum load is 1000 g (=1000 digits). If the interval of the connected instrument is 5 g and the same number of intervals is required as in the example above, the minimum load is 5000 g.

Once the load on the weighing instrument exceeds the specified minimum, the instrument is tared and/or a printout is generated, if the operating menu is configured for automatic taring (menu item 3.7.2) and/or automatic printing (menu item 7.13.2).

Automatic Printing (Menu Item 7.13)

When menu item 7.13.2 is active, the first weight value that exceeds the specified minimum load is printed.

If the menu code for automatic taring is also active, the weighing instrument is only tared when the minimum load is exceeded; the value is not printed.

First Weighing Instrument Displayed (Combics 2 only)

You can define which weighing instrument shows the first weight value when you switch on the Combics, under μE IL $!E$ (menu item 8.9).

Entering Tare Weight using a Bar Code Scanner (Combics 1 plus and Combics 2 only)

You can enter the tare value of a container using a bar code scanner. To do this, the "Store value as tare" ($E R E$) menu item must be selected under "Setup > Bar code" in the operating menu. In this case, the value is stored as the tare automatically, without pressing the $\square Tare$ key. The contents of the tare memory are display in Info mode (press and hold $\square \text{Info}$).

Entering ID Codes using a Bar Code Scanner (Combics 1 plus only)

You can use a bar code scanner to enter ID codes. To do this, the "Store value as ID1" ($id i$) menu item must be selected under "Setup > Bar code" in the operating menu. In this case, the value is stored as ID1 automatically, without pressing the $\square ID1$ key. To store the second ID code, the $\square ID2$ key must be pressed.

- To view the stored ID codes:
- Press $\square Info$ and $\square ID1$
 - Press $\square Info$ and $\square ID2$

Calibration/Configuration Counter on Standard Weighing Instruments

Purpose

These two mutually independent counters automatically keep track of changes made in calibration/adjustment parameters and in the operating menu. Counter values are stored in an EEPROM, and remain stored during the entire service life of this memory chip. To view the current values in the counter, press and hold the $\boxed{\leftrightarrow}$ key (longer than 2 sec). The readout shows the "configuration counter" value for 3 seconds first (identified by "P"). Then the "calibration counter" value is shown for 3 seconds (identified by "C"). The information display closes automatically after 6 seconds.

Features of the Calibration Counter:

- Limited to a count of 9999
- Counter set to "C 0000" when the hardware is first put into operation
- Counter cannot be reset
- The counter value is updated ("1" is added) automatically following:
 - Successful calibration/adjustment or linearization
 - Changes in the user-defined calibration/adjustment or linearization weight (menu item 1.18)
 - Changes in any of the following parameters:
 - Function of the \boxed{CAL} key (menu item 1.9)
 - Zero-setting range (menu item 1.11)
 - Initial zero-setting range (menu item 1.12)
 - Resetting of the above parameters to factory settings (menu item 9.1.1)

Features of the Configuration Counter:

- Limited to a count of 9999
- Counter set to "P 0000" when the hardware is first put into operation
- Counter cannot be reset
- The counter value is updated ("1" is added) automatically following:
 - Changes in the following parameters:
 - Place of installation (menu item 1.1)
 - Application filter (menu item 1.2)
 - Stability range (menu item 1.3)
 - Taring (menu item 1.5)
 - Auto zero (menu item 1.6)
 - Weight unit 1 (menu item 1.7)
 - Weight unit 2 (menu item 3.1)
 - Weight unit 3 (menu item 3.3)
 - Resetting of the above parameters to factory settings (menu item 9.1.1)
 - Function of the \boxed{Fn} key changed to or from 10-fold higher resolution display
 - Activation or deactivation of application-dependent automatic taring (menu item 3.7)
 - Resetting of the application parameters to factory settings (menu code 9.1.1)

Device parameters

Password

You can prevent unauthorized changes in the device settings ("SETP") and application settings ("APP", "Combics 2 only) by assigning a password under "Setup > Code" (CODE; see also the chapter entitled "Configuration").

Acoustic Signal

An acoustic signal is emitted when you press a key (active key: single beep; inactive key: double-beep). You can switch the acoustic signal off or on under "Setup > Utilities" (SETP, UT IL IL) (menu item 8.2).

Keys

In the Setup menu under "UT IL IL," you can block or release the keypad for input (menu item 8.3).

Automatic Power-off

In the Setup menu under "UT IL IL" you can configure the Combics to shut down automatically following a specified interval of no user activity (menu item 8.7).

Display Backlighting

In the Setup menu under "UT IL IL" you can choose from the following settings for the display backlighting:

- On (8.8.1)
- Off (8.8.2)
- Shut off after the specified time period has elapsed (8.8.3)

Timer Mode

In the Setup menu under "UT IL IL" you can set the timer interval to 2, 4 or 10 minutes (menu item 8.9).

Operating

Example

Switch on the Combics, zero the weighing instrument, tare the container weight, place sample in container, toggle display to gross weight, 2nd weight unit or 10-fold increased resolution



Switch on the Combics



All display segments are shown for approx. 1 second (self-test)



Display with no load on weighing instrument



Zero the weighing instrument



Display with no load on weighing instrument

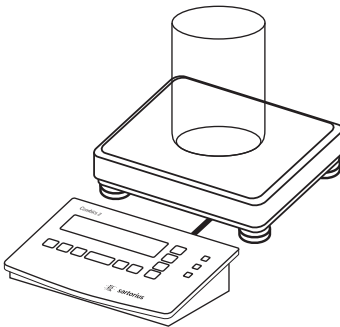

Place container on weighing instrument



Container weight is displayed



Tare the weighing instrument



Display with tared container on weighing instrument

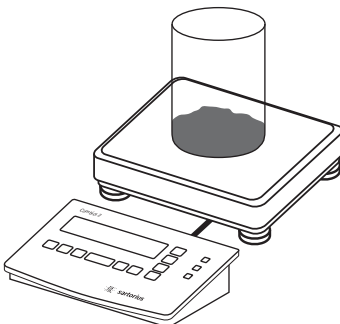

Place sample in container (in this example, 120.2 g)



Display with tared weighing instrument and sample in container

Fn

Toggle display; readout depends on your settings:

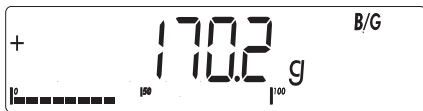

gross weight
(in this example, 50 g for container + 120.2 g substrate) or



display in 2nd weight unit (in this example, kg) or



display with 10-fold increased resolution

Fn

Return to previous readout
(if 10-fold increased resolution is shown, display returns to previous readout automatically after 10 seconds)



Print

Print results

ACE HARDWARE
GOETTINGEN
24.02.2002 15:10

G#	+	170.2	g
T	+	50.0	g
N	+	120.2	g

Operating

Example:

Combics 1 plus: Weighing with tare value entered using the numeric keypad; generate printout of results



Switch on the Combics 1 plus

The automatic self-test runs. Once a readout is shown, Combics 1 plus is automatically zeroed and ready to operate. With no load on the weighing instrument, you can zero the instrument at any time by pressing $\rightarrow 0 \leftarrow$.

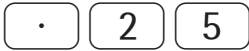

Enter the tare weight in the current weight unit using the keypad (in this example, 0.25 kg).



Tare the weighing instrument

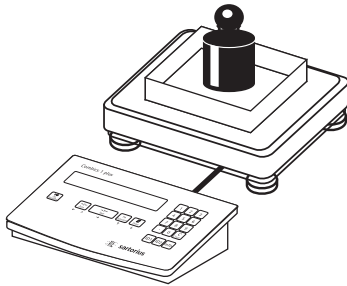

Place container with sample on the weighing instrument



Read the result



Toggle the display from net to gross weight values. The display shows



the gross weight (in this example, 0.250 kg for the container plus 2.000 kg for the sample)

Fn

Toggle to display of net value

+ 2000 kg NET

Print

Print the results

05.04.2004 10:09
Model CW1NP1-30ED-LOCE
Ser.no. 12345678
Vers. 1.0001.04.4
BVers. 01-33-01

Start of GMP header (only if GMP-compliant printout is configured)

ACE HARDWARE
GOETTINGEN
Batch no. 123456
Customer 6.789
05.04.2004 10:09

End of GMP header
Header lines

ID code 1
ID code 2

G# + 2.250 kg
T + 0.000 kg
PT2 + 0.250 kg
N + 2.000 kg

GMP footer (only if GMP-compliant printout is configured)

05.04.2004 10:10
Name :

End of GMP footer

C + **→T←**

Delete tare weight entered through the keypad

or

0 + **→T←**

Example:

Combics 1 plus: Weighing with varying tare values; generate printout of results, delete tare values



Switch on the Combics 1 plus
The automatic self-test runs. Once a readout is shown, the Combics is automatically zeroed and ready to operate. With no load on the weighing instrument, you can zero the instrument at any time by pressing $\rightarrow 0 \leftarrow$.

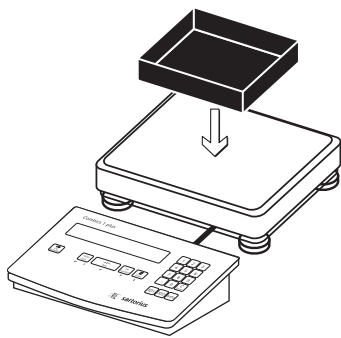

Place empty container on the weighing instrument



Tare the weighing instrument
Note: With the automatic tare function enabled, you do not need to press $\rightarrow T \leftarrow$ to tare the weighing instrument; the tare weight is stored automatically when you place the container on the weighing instrument.



Wait until a zero value is displayed together with the NET symbol.

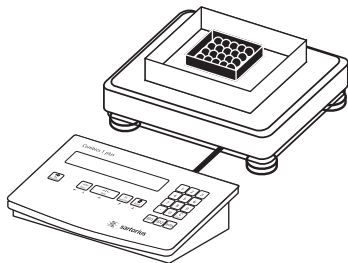

Place packaged sample in the container

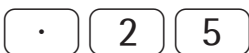

Enter the tare weight of the packaging in the current weight unit using the keypad (in this example, 0.25 kg).



Save the package weight. The package tare is added to the container tare.



Read off net weight



Print the results

G#	+	6.433	kg
T	+	4.183	kg
PT2	+	0.250	kg
N	+	2.000	kg



Enter a zero ("0") using the keypad



Save the value entered. This deletes tare values; the display shows the gross value



Print the results

G#	+	6.433	kg
T	+	0.000	kg
N	+	6.433	kg

Individual ID Codes (Identifiers)

You can assign ID codes (such as product name, batch number, etc.) while weighing, for identification of measured values.

Features

- Assign up to two ID codes.
- Assign both a name and a value for each ID code.
- The name is left-justified and the value is right-justified on the printout. If the entire code is too long for one line, additional lines are printed.
- Enter ID code names in Setup under: *SEtUP: PrtPrOt* (printouts):
7.4.3 (ID1)
and
7.4.4 (ID2)
- Enter up to 20 characters for the ID code name. No more than 11 characters are displayed during input; all 20 characters are printed.
- Maximum length for values: 21 characters.
- Enter numeric values for ID codes using the numeric keypad and press **ID1** or **ID2** to save.
- To delete the last character entered in the ID code value: Press **C**
To delete the entire ID code: Press **C** and then **ID1** or **ID2**
- If both the name and value fields are empty, no ID code is printed.

- Print ID codes: Refer to the Setup menu for menu item numbers. Data is output to COM1 menu item 7.7.x) or UniCOM (menu item 7.8.x).
- Show ID codes: Press **Info** and then **ID1** or **ID2**
- To store values entered using a bar code scanner: Scan the value for ID1

Function Keys

ID1 Store the input as value for first or
ID2 second ID code.

C Delete the selected ID code value

Info Display ID codes

Application Parameters: ID Codes

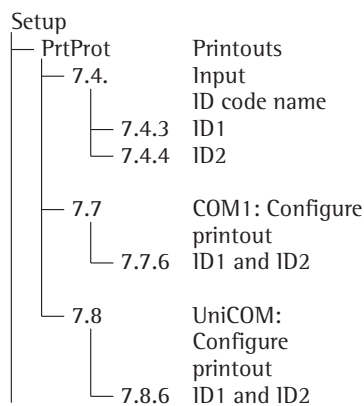

Example:

Entering ID code values.

Enter "123.456" and "678.9" as values for ID codes 1 and 2.

See "Entering the Password" in the chapter entitled "Configuration" for details on how to enter ID code names.

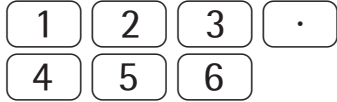

Enter value for ID code 1 (in this example, 123.456)



Confirm value for the first ID code



Enter value for ID code 2 (in this example, 678.9)



Confirm the value for the second ID code

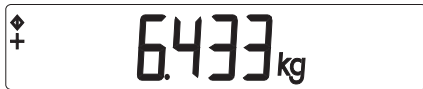

Place container with sample on the weighing instrument



Print weight value (perform further weighing operations as desired, and print)

ID1		123.456
ID2		6.789
24.02.2003		10:09

ID code 1
ID code 2

Ser.no.	12345678
G#	+ 6.433 kg
T	+ 0.000 kg
N	+ 6.433 kg



Delete ID code:
You can delete each ID code individually when the weighing series has been completed.



Operation

Calibration and Adjustment

Purpose

The accuracy of weighing results must be carefully controlled. This is achieved through calibration and adjustment.

Calibration technically means to determine the difference between the weighing instrument readout and the actual weight on the platform to determine the accuracy. This does not involve making any changes in the scale.

Adjustment means to bring a weighing instrument to the level of accuracy required for its use.

Configuring Functions for Use of the Scale in Legal Metrology

To set any of the Combics scales for use in legal metrology, use the switch located on the back on the left of indicator housing. This switch is covered by a cap.

On CH models, there is an additional switch on the scale. To set the switch to the correct position, please refer to the corresponding drawing ("Plates and Markings") in this instruction manual.

To use the scale as a legal for trade instrument, all switches must be in the "locked" position.

Example

External calibration and manual adjustment with default weights

Setup menu settings:
1.9.1; 1.10.2



Unload and zero the weighing instrument



Start calibration (e.g., when calibration prompt is flashing: $\Delta\Delta$)



The following is displayed for 2 seconds



You are prompted to place the required weight on the weighing instrument (e.g., 10 kg)

Features for CW-Modelle

Settings in the Setup menu:

- External calibration/adjustment with the default weight value or standard weight (1.9.1) (not available on verified instruments)
- External calibration/adjustment with a user-defined weight (1.9.3) (not available on verified instruments)
- Internal calibration/adjustment for IS platform (1.9.4), WP2 only
- Block the $\rightarrow T \leftarrow$ key to prevent use of the two functions described above (1.9.10)
- Calibrate first; then adjust automatically (1.10.1) (not available on verified instruments)
- Calibrate, then prompt for manual input of adjustment command (1.10.2)
- Calibration prompt: flashing $\Delta\Delta$ symbol (1.15.2). If more than one weighing instrument is connected, the instrument number is also displayed.
- Block external calibration/adjustment (1.16.2)

CW Scales

- Display altitude and geographical latitude or acceleration of gravity after $\square CAL$ is shown at the beginning of the calibration procedure (menu item 8.12.2). These values are shown only if they have been entered in the service menu and activated.
For each of these parameters, the term is displayed first (RLT $LEUD$, LAL $LEUD$ or $GRAV$ $LEUD$) for 1 second, and then the corresponding value is displayed continuously until you press $\rightarrow T \leftarrow$.

Note

On verified weighing instruments, the external calibration/adjustment function is available only when the menu access switch is in the "open" position, which entails breaking the verification seal (refer to the chapter entitled "Care and Maintenance"). The equipment must be re-verified after the seal has been broken.

CH Scales

- Using a verified scale as a legal measuring instrument:
Before using the scale as a legal measuring instrument, you must carry out an internal calibration operation by selecting the "Internal Calibration" function at the place of installation.
- To do so, press and hold the --- key. During internal calibration, "CI" (for internal calibration) appears in the display. Once the calibration procedure is complete, a weight will be displayed automatically.

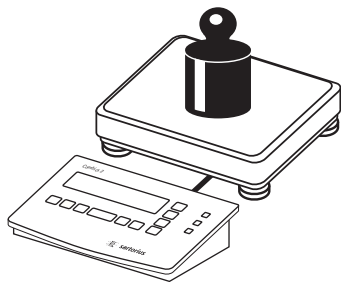

Position the calibration weight on the weighing instrument



The difference between the weight value and the true mass is displayed, with ± sign.

```
External calibration
Nom. + 10000.0 g
Diff. - 0.3 g
-----
```

Calibration record is printed, if adjustment was not performed and the process was stopped by pressing $\rightarrow 0 \leftarrow$



Activate calibration/adjustment manually (press the $\rightarrow 0 \leftarrow$ key to cancel)



The calibration weight is displayed at the conclusion of calibration

```
-----
14.01.2002 13:00
Model CW2P1-30ED-LCE
Ser.no. 12345678
Vers. 1.1007.12.1
BVers. 01-25-01
-----
```

A GMP-compliant printout is generated

```
External calibration
Nom. + 10000.0 g
Diff. - 0.3 g
External adjustment
Diff. + 0.0 g
-----
```

```
14.01.2002 13:02
Name:
-----
```

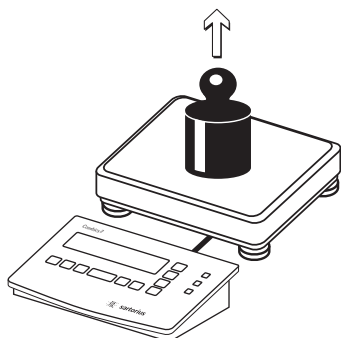

Unload the weighing instrument

Counting ☼

With the Counting application, you can determine the number of parts that each have approximately equal weight.

Features:

- Store the weight on the weighing instrument as reference weight
- Enter reference weight using a bar code scanner
- Enter tare weight using a bar code scanner
- Automatic reference sample updating (user-definable)
- Counting with two weighing instruments
- Toggle the display between piece count and weight by pressing **[↵]**
- Info mode for display of average piece weight and reference sample quantity by pressing **[↵]** (> 2 sec)

Before the quantity on the weighing instrument can be calculated, the average piece weight must be entered in the application. There are 2 ways to do this with the Combics:

- By placing the number of parts defined as the reference sample quantity on the weighing instrument and pressing **[OK]** to store the average piece weight.

The reference sample quantity is shown in the numeric display, and can be changed by pressing **[REF]**.

How the reference weight is calculated depends on the menu setting for resolution (3.9). Either the value is rounded off in accordance with the display resolution, or the display resolution is increased 10-fold (+1 decimal place) or 100-fold (+ 2 decimal places), or maximum internal resolution is applied.

- By entering the reference piece weight (i.e., the weight of one piece) using a bar code scanner (menu setting: "Setup> Bar code > Store value as reference (REF)"). In this case, the value is stored as a reference automatically, without pressing the **[OK]** key.

This value remains active in the reference memory until you delete it by pressing **[CF]**, overwrite it or until you select a different application. It also remains in memory when you switch to a different application program, or switch off the Combics.

- Tare function:
 - 1) If you store a tare (weight value) by pressing the **[⇄]** key, you can later enter a tare value manually. The tare value you enter is added to the stored tare value.
Setting: menu code 3.25.1 (factory default)
 - 2) A tare value entered manually overwrites a stored tare value (weight value). If you enter a tare value manually, a tare value (weight value) stored later overwrites the manually entered value.
Setting: menu code 3.25.2
Operating menu setting:
APPL : ☼ : 3.25.

Application Parameters: Counting

- 3. 5. Minimum Load for Automatic Taring and Automatic Printing
 - 3. 5. 1* 1 digit
 - 3. 5. 2 2 digits
 - 3. 5. 3 5 digits
 - 3. 5. 4 10 digits
 - 3. 5. 5 20 digits
 - 3. 5. 6 50 digits
 - 3. 5. 7 100 digits
 - 3. 5. 8 200 digits
 - 3. 5. 9 500 digits
 - 3. 5.10 1000 digits
- 3. 6. Minimum Load for Initialization
 - 3. 6. 1* 1 digit
 - 3. 6. 2 2 digits
 - 3. 6. 3 5 digits
 - 3. 6. 4 10 digits
 - 3. 6. 5 20 digits
 - 3. 6. 6 50 digits
 - 3. 6. 7 100 digits
 - 3. 6. 8 200 digits
 - 3. 6. 9 500 digits
 - 3. 6.10 1000 digits
- 3. 7. Automatic Taring: 1st Weight Tared
 - 3. 7. 1* Off
 - 3. 7. 2 On
- 3. 8. Start Application with Most Recent Application Data when Combics is Switched On
 - 3. 8. 1 Automatic (on)
 - 3. 8. 2* Manual (off)
- 3. 9. Resolution for Calculation of Reference Value
 - 3. 9. 1* Display resolution
 - 3. 9. 2 Display resolution + 1 decimal place
 - 3. 9. 3 Display resolution + 2 decimal places
 - 3. 9. 4 Internal resolution
- 3.11 Storage Parameter
 - 3.11. 1* At stability
 - 3.11. 2 At increased stability
- 3.12. Reference Sample Updating
 - 3.12. 1 Off
 - 3.12. 3* Automatic
- 3.13. Reference Weighing Instrument
 - 3.13. 1* No reference instrument selected
 - 3.13. 2 WP1
 - 3.13. 3 WP2
- 3.25. Tare function
 - 3.25. 1* The tare value entered is added to the stored tare value
 - 3.25. 2 Overwritable tare value

Storage Parameter

The reference weight is saved when the weighing instrument has stabilized. "Stability" is defined as the point at which fluctuation of a measured value lies within a defined tolerance range. The narrower the tolerance range, the more stable the weighing instrument is at "stability." This setting is also applied when you zero the weighing instrument.

Under menu item 3.11 you can determine whether the value is saved "At stability" (normal tolerance range) or "At increased stability" (narrower tolerance range).

If you select "At increased stability," the average piece weight stored will be more accurate and the results more reproducible, but the response time of the weighing instrument might be longer.

Minimum Load for Initialization

The minimum load for initialization is configured under menu item 3.6. If the load exceeds this limit, the weighing instrument can be initialized. If the load is too light, the following will occur when you try to save a value:

- The error code *1nF 29* is displayed
- A warning signal is emitted (double-beep)
- The weighing instrument is not initialized
- The preset reference sample quantity is stored

Reference Sample Updating

In the Application settings under 3.12, you can define whether the reference sample is updated automatically. Reference sample updating is performed automatically only when the following 6 criteria are met:

1. Menu item 3.12.3 is active
2. The current piece exceeds the original piece count by at least two
3. The current piece count is less than twice the original piece count (does not apply for the first update if the piece count is entered using a bar code scanner).

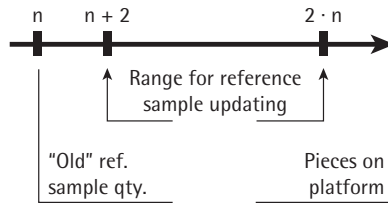

4. The current piece count is less than 100.
5. The internally calculated piece count (such as 17.24 pcs) differs by less than ± 0.3 pcs from the whole number (17 pcs in this example).
6. The weighing instrument is stable in accordance with the defined stability parameter.

When automatic reference sample updating is active, the AUTO symbol is displayed in addition to the Counting symbol (♣). When the reference sample has been updated, OPT is displayed below AUTO. During an updating operation, OPT and the updated piece count are displayed briefly in the main display.

At the conclusion of reference sample updating, a beep is sounded and the new reference weight and reference sample quantity are stored. Activate the "Info" mode to view the reference values (press and hold [S] > 2 sec).

Counting with Two Weighing Instruments

You can use two weighing instruments simultaneously with the Counting application. When using two instruments, you can choose from the following operating modes:

- Counting with two equivalent weighing instruments
- Counting with one reference weighing instrument and one counting platform

Counting with Two Equivalent Weighing Instruments

Use this mode when samples of widely varying weight are counted at one workstation. Count the lighter-weight pieces on one weighing instrument and the heavier pieces on another. When you press [TAB] to toggle from one weighing instrument to the other, the application is re-initialized. You can define which of the two weighing instruments is active in the display when the Combics is switched on (menu item 8.11). This is the first weighing instrument active when you switch on the Combics, regardless of the setting for automatic initialization of the Counting application.

Counting with One Reference Weighing Instrument and One Counting Platform

In this mode, a high-resolution weighing instrument with a relatively low maximum capacity is used as a reference weighing instrument. The weighing platform is used for weighing heavier samples, and has a high capacity with a relatively low resolution. This way, you can both determine the reference sample quantity very precisely and count large amounts of parts, without requiring an expensive high-resolution, high-capacity weighing platform. Specify which weighing instrument is the reference instrument under menu item 3.13. The system toggles automatically to the reference weighing instrument for initialization (*rEF* is displayed). Following initialization, the system toggles to the counting platform.

The system does not toggle automatically for automatic reference sample updating; the update is based on whichever instrument is active.

Example:

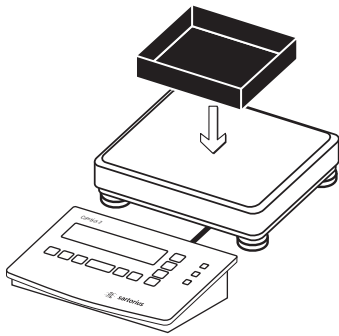

Place empty container on the weighing instrument



Tare the weighing instrument



Set the desired reference sample quantity (in this example, 20)

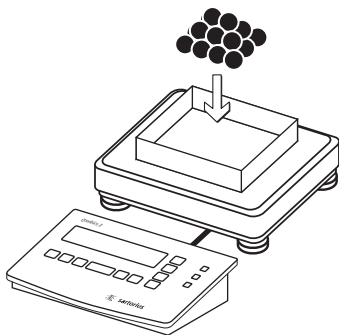

Place the corresponding number of pieces (20) in the container



Confirm reference sample weight



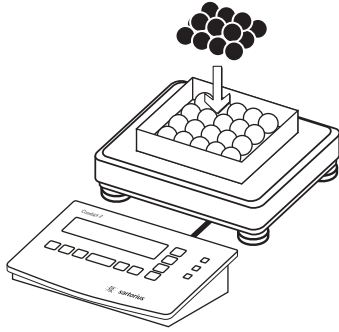

Add more parts to the container (in this example, 18 pcs)



OPt is displayed if automatic reference sample updating is enabled



Toggle the display from piece count to weight

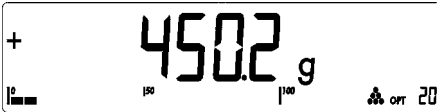

< 2 sec.

Toggle to Info mode

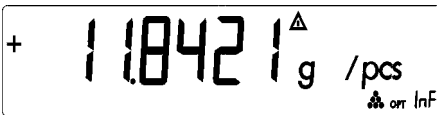

Piece count is displayed



Toggle to the next display mode

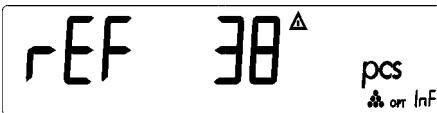

Reference sample quantity is displayed



(> 2 sec)

Return to weighing mode





Print results

G#	+	610.0 g
T	+	200.0 g
N	+	410.0 g
Qnt		38 pcs

Neutral Measurement

When the Neutral Measurement application is selected, you can use your weighing instrument to measure the length, surface and volume of parts that have roughly the same specific weight. The *o* symbol is displayed as the weight unit.

Features:

- Store the weight on the weighing instrument as reference weight
- Enter reference weight using a bar code scanner
- Enter tare weight using a bar code scanner
- Toggle the display between weight and calculated value by pressing 
- Info mode for display of reference weight by pressing  (> 2 sec)

To calculate the result correctly, the average weight of a reference quantity must be known (in the example below, the reference is 1 meter of electrical cable). There are 2 ways to do this with the Combiics:

- By placing the number of parts defined for the reference value on the weighing instrument and pressing  to store the average piece weight.

The reference value is shown in the numeric display, and can be changed by pressing .

How the reference weight is calculated depends on the menu setting for resolution (3.9). Either the value is rounded off in accordance with the display resolution, or the display resolution is increased 10-fold (+1 decimal place) or 100-fold (+ 2 decimal places), or maximum internal resolution is applied.

- By entering the reference weight (i.e., the weight of one piece) using a bar code scanner (menu setting: "Setup> Bar code > Store value as reference (REF)"). In this case, the value is stored as a reference automatically, without pressing the  key.

This value remains active in the reference memory until you delete it by pressing , overwrite it or until you select a different application. It also remains stored after you switch off the Combiics.

- Tare function:
 - 1) If you store a tare (weight value) by pressing the  key, you can later enter a tare value manually. The tare value you enter is added to the stored tare value.
Setting: menu code 3.25.1 (factory default)
 - 2) A tare value entered manually overwrites a stored tare value (weight value). If you enter a tare value manually, a tare value (weight value) stored later overwrites the manually entered value.
Setting: menu code 3.25.2

Operating menu setting:

APPL :  : 3.25.

Application Parameters: Neutral Measurement

- 3. 5. Minimum Load for Automatic Taring and Automatic Printing
 - 3. 5. 1 * 1 digit
 - 3. 5. 2 2 digits
 - 3. 5. 3 5 digits
 - 3. 5. 4 10 digits
 - 3. 5. 5 20 digits
 - 3. 5. 6 50 digits
 - 3. 5. 7 100 digits
 - 3. 5. 8 200 digits
 - 3. 5. 9 500 digits
 - 3. 5.10 1000 digits
- 3. 6. Minimum Load for Initialization
 - 3. 6. 1 * 1 digit
 - 3. 6. 2 2 digits
 - 3. 6. 3 5 digits
 - 3. 6. 4 10 digits
 - 3. 6. 5 20 digits
 - 3. 6. 6 50 digits
 - 3. 6. 7 100 digits
 - 3. 6. 8 200 digits
 - 3. 6. 9 500 digits
 - 3. 6.10 1000 digits
- 3. 7. Automatic Taring:1st Weight Tared
 - 3. 7. 1 * Off
 - 3. 7. 2 On
- 3. 8. Start Application with Most Recent Application Data when Combiics is Switched On
 - 3. 8. 1 Automatic (on)
 - 3. 8. 2 * Manual (off)
- 3. 9. Resolution for Calculation of Reference Value
 - 3. 9. 1 * Display resolution
 - 3. 9. 2 Display resolution + 1 decimal place
 - 3. 9. 3 Display resolution + 2 decimal places
 - 3. 9. 4 Internal resolution
- 3.10. Decimal Places for Display of Results
 - 3.10. 1 * None
 - 3.10. 2 1 decimal place
 - 3.10. 3 2 decimal places
 - 3.10. 4 3 decimal places
- 3.11. Storage Parameter
 - 3.11. 1 * At stability
 - 3.11. 2 At increased stability
- 3.13. Reference Weighing Instrument
 - 3.13. 1 * Off
 - 3.13. 2 WP1
 - 3.13. 3 WP2
- 3.25. Tare function
 - 3.25. 1 * The tare value entered is added to the stored tare value
 - 3.25. 2 Overwritable tare value

Storage Parameter

The reference weight is saved when the weighing instrument has stabilized. "Stability" is defined as the point at which fluctuation of a measured value lies within a defined tolerance range. The narrower the tolerance range, the more stable the weighing instrument is at "stability." This setting is also applied when you zero the weighing instrument.

Under menu item 3.11 you can determine whether the value is saved "At stability" (normal tolerance range) or "At increased stability" (narrower tolerance range).

If you select "At increased stability," the average piece weight stored will be more accurate and the results more reproducible, but the response time of the weighing instrument might be longer.

Decimal Places for Display of Results

In neutral measurement, not only whole numbers but also decimal numbers (for example, 1.25 o electrical cabling) can be displayed. The number of decimal places displayed in neutral measurement is configured under menu item 3.10. The measured result can be displayed with 0, 1, 2 or 3 decimal places.

Minimum Load for Initialization

The minimum load for initialization is configured under menu item 3.6. If the load exceeds this limit, the weighing instrument can be initialized. If the load is too light, the following will occur when you try to save a value:

- The error code *inF 29* is displayed
- A warning signal is emitted (double-beep)
- The weighing instrument is not initialized
- The preset reference value is stored

Neutral Measurement with Two Weighing Instruments

You can use two weighing instruments simultaneously with the Neutral Measurement application. When using two instruments, you can choose from the following operating modes:

- Neutral measurement with two equivalent weighing instruments
- Neutral measurement with one reference weighing instrument and one measurement platform

Neutral Measurement with Two Equivalent Weighing Instruments

Use this mode when samples of widely varying weight are measured at one workstation. Measure the lighter-weight pieces on one weighing instrument and the heavier pieces on another. When you press \overline{AVA} to toggle from one weighing instrument to the other, the application is re-initialized.

You can define which of the two weighing instruments is active in the display when the Combics is switched on (menu item 8.11). This is the first weighing instrument active when you switch on the Combics, regardless of the setting for automatic initialization of the Neutral Measurement application.

Neutral Measurement with One Reference Weighing Instrument and One Measuring Platform

In this mode, a high-resolution weighing instrument with a relatively low maximum capacity is used as a reference weighing instrument. The measuring platform has a high capacity, but a relatively low resolution.

This allows you to both determine the reference value with high resolution; i.e., very precisely, and to measure large samples, without requiring an expensive high-resolution, high-capacity weighing platform.

Specify which weighing instrument is the reference instrument under menu item 3.13. The system toggles automatically to the reference instrument for initialization (*rEF* is shown in the main display). Following initialization, the system toggles to the measuring platform.

Example:

Determine the length of an amount of electrical cable after weighing in the defined reference unit value

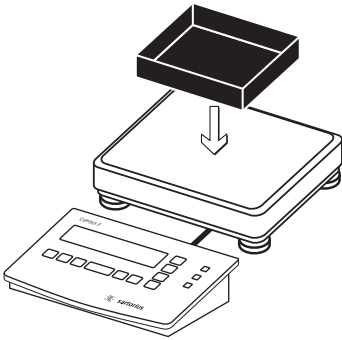

Place empty container on the weighing instrument



Tare the weighing instrument



REF (repeatedly, if necessary)

Set the desired reference value (in this example, 2)

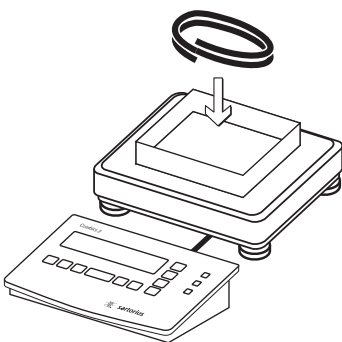

Place a sample corresponding to the reference quantity in the container (in this example, 2 meters of electrical cable)



Confirm reference sample weight



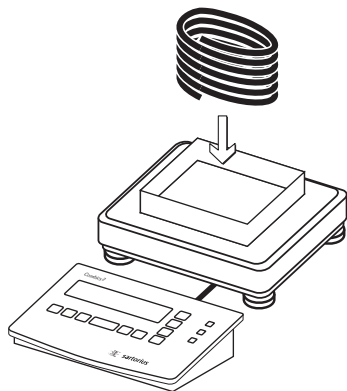

Remove the reference material and place the sample to be measured on the weighing instrument (in this example, 8 meters of electrical cable)



Print results

G#	+	734.1	g
T	+	200.0	g
N	+	534.1	g
Qnt		8	o

Checkweighing $\%$

When the Checkweighing application is selected, you can check whether sample weights correspond to a specified target weight; i.e., whether the weight on the weighing instrument is within a given tolerance range. The tolerance range is defined by upper and lower limits. The result is displayed in the main indicator, in the bar graph and by color-coded LEDs.

Features:

- The target value can be taken over as a weighed value from a weighing instrument, and the tolerance limits are defined as a perceptual deviation from the target value. The following percentages can be selected as the deviation: 0.1%, 0.2%, 0.5%, 1%, 1.5%, 2%, 3%, 5% or 10%.
- The target value, lower tolerance limit (minimum) and upper tolerance limit (maximum) can be taken over as weighed values from the weighing instrument.
- Target and tolerance limits checked during input; values must conform to: Upper limit \geq Target \geq Lower limit \geq 1 digit
- Checkweighing range: either 30% to 170% of the target, or from 10% to infinity
- Application started automatically with most recent application data when Combics switched on
- Automatic taring
- Automatic printing
- Toggle the display between weight and tolerances limits by pressing (S). When tolerances are displayed, weights exceeding the tolerance limits are shown with "LL" (too low) or "HH" (too high).
- Digital input/output interface
- Info mode for display of tolerance limits by pressing (S) (> 2 sec)

Checkweighing entails comparing the current weight value to a defined target. The target value has a tolerance range which can be entered either as an absolute value or percentage (menu item 4.5).

- Entering the tolerance range as an absolute value (weighed value) (menu item 4.5.1):
Start initialization by pressing (OK); the middle segments of the bar graph flash to prompt the placement of the weight on the weighing instrument. Place the weight on the instrument and press (OK) to store.
The bar graph segment for the lower limit flashes to prompt the weight for lower limit. Place the weight on the weighing instrument and press (OK) to store.
The bar graph segment for the upper limit flashes to prompt the weight for upper limit. Place the weight on the weighing instrument and press (OK) to store.
- Entering the tolerance range as a percentage (menu item 4.5.2):
A value for the percentage is shown in the numeric display (lower right-hand corner) together with the "%" sign. Press (REF) to change the percentage value (0.1%, 0.2%, 0.5%, 1%, 1.5%, 2%, 3%, 5%, 10%).
Start initialization by pressing (OK); the middle segments of the bar graph flash to prompt the placement of the weight on the weighing instrument. Place the weight on the instrument and press (OK) to store. To can change the percentage value for the tolerance limits again before the target value is stored, press (REF).

Before the new initialization, the previous initialization values must be deleted by pressing (CF).

- Tare function:
 - 1) If you store a tare (weight value) by pressing the (T+) key, you can later enter a tare value manually. The tare value you enter is added to the stored tare value.
Setting: menu code 3.25.1 (factory default)
 - 2) A tare value entered manually overwrites a stored tare value (weight value). If you enter a tare value manually, a tare value (weight value) stored later overwrites the manually entered value.
Setting: menu code 3.25.2
Operating menu setting:
APPL : $\%$: 3.25.

Application Parameters: Checkweighing

3. 5.	Minimum Load for Automatic Taring and Automatic Printing
3. 5. 1 *	1 digit
3. 5. 2	2 digits
3. 5. 3	5 digits
3. 5. 4	10 digits
3. 5. 5	20 digits
3. 5. 6	50 digits
3. 5. 7	100 digits
3. 5. 8	200 digits
3. 5. 9	500 digits
3. 5.10	1000 digits
3. 7.	Automatic Taring: 1st Weight Tared
3. 7. 1 *	Off
3. 7. 2	On
3. 8.	Start Application with Most Recent Application Data when Combics is Switched On
3. 8. 1	Automatic (on)
3. 8. 2 *	Manual (off)
3.25.	Tare function
3.25. 1 *	The tare value entered is added to the stored tare value
3.25. 2	Overwritable tare value
4. 2.	Checkweighing Range
4. 2. 1 *	30% to 170%
4. 2. 2	10% to infinity
4. 3.	Activate Control Line for "Set" as:
4. 3. 1 *	"Set" output
4. 3. 2	Ready to operate
4. 4.	Activation of Outputs
4. 4. 1	Off
4. 4. 2	Always active
4. 4. 3	Active at stability
4. 4. 4 *	Active within checkweighing range
4. 4. 5	Active at stability within the checkweighing range
4. 5.	Parameter Input
4. 5. 1 *	Min, max, target
4. 5. 2	Only target with percent limits
4. 6.	Automatic Printing
4. 6. 1 *	Off
4. 6. 2	On
4. 6. 3	Only values within tolerance
4. 6. 4	Only values outside tolerance

Display

The result of a measurement is shown either as a weight value or in relation to the target. You can toggle between these two display modes by pressing **[S]**.

- Weight display mode:
 - The main display always shows the weight value, even if the value is outside the tolerance range.
 - The bar graph is displayed with symbols indicating lower limit, target and upper limit. It shows a logarithmic display of the current load if the weight is anywhere from 0 to the minimum load, and a linear display for weights beyond that range.
 - The LEDs indicate the following:
 - Yellow: weight value > upper tolerance limit
 - Green: weight value is within tolerance
 - Red: weight value < lower tolerance limit
 - If no LED lights up:
 - the application is not completely initialized, or
 - the weight value is outside the checkweighing range (see menu item 4.2)
 - the weighing instrument has not stabilized
- Tolerance limit display mode:
 - As "Weight display mode" above, with the exception that:
 - LL is shown on the main display if the weight value is lower than the target, and
 - HH is shown on the main display if the weight value is higher than the target

Digital Input/Output Interface

The Checkweighing application supports the digital input/output interface. There are 4 control lines, or outputs, which are activated as follows (also refer to the diagram):

- Lighter
 - Equal
 - Heavier
 - Set
- The "SET" output normally changes its voltage level when the load is near the target weight. Alternatively, you can assign the "Ready-for-use" function to this port (menu item 4.3.2).
- Under menu item 4.4, you can define whether these control ports are
- inactive (4.4.1)
 - always active (4.4.2)
 - active at stability (4.4.3)
 - active within the check range, or
 - active at stability within the check range
- For example, you can use this function to show the weighed or measured result on a simple external indicator, similar to the 3 LEDs on the Combics 2.

All data output ports have a high voltage level when:

- the application has not been initialized,
- the weighing instrument is not at stability and one of the "at stability..." parameters, (4.4.3 or 4.4.5) is selected, or
- the weight is not within the check range (4.4.4).

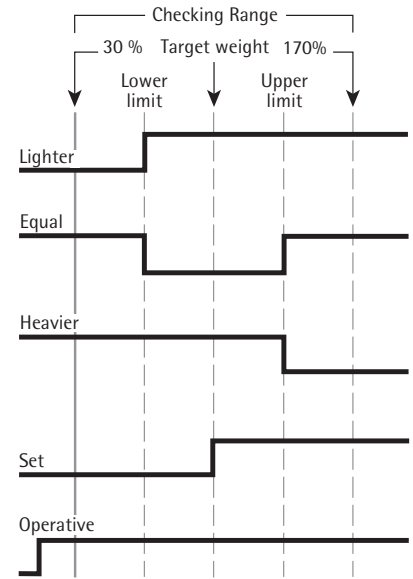

Digital I/O Interface
"SET" control line: set and control lines: Always active/Active at stability

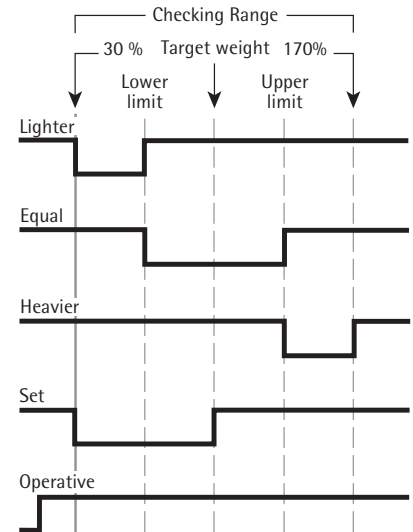

Digital I/O Interface
"SET" control line: set and control lines: active within checkweighing range/ Active within checkweighing range at stability

Output line specifications:

- In the inactive state, the levels are set to "high:" > 3.7 V/+4 mA
- In the active state, the levels are set to "low:" < 0.4 V/-4 mA

⚠ The output lines are not short-circuit proof!

Example:

Initialize the Checkweighing application by taking over the weighed value as target; select percentage to define tolerance range (menu item 4.5.2)

CF

Delete any existing initialization data



OK

Begin initialization



The middle segments of the bar graph flash to prompt the placement of the weight on the weighing instrument

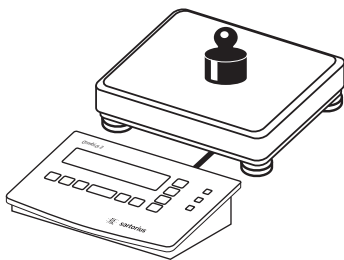

Place the weight for the target on the weighing instrument (in this example, 100.0 g)



REF repeatedly, if necessary

Select the desired percentage for tolerance limits (in this example, 5%)



OK

Store target and calculate tolerance range based on the selected percentage



Optional:  < 2 sec.

Toggle to Info mode to view stored values



Target value is displayed



Toggle to the next display mode



Percentage for limits is displayed



Toggle to the next display mode

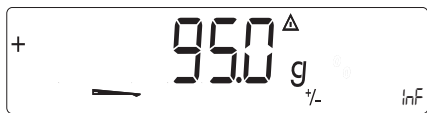

Weight value for the lower limit (minimum) is displayed



Toggle to next display mode (weight value for the upper limit is displayed)



Exit the Info mode

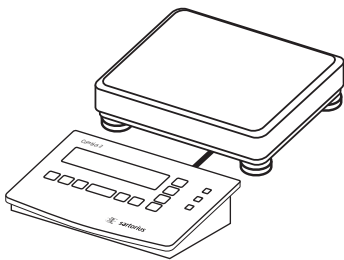

Unload weighing instrument



Example:

Check the weight of a sample; use Tolerance Limit display mode

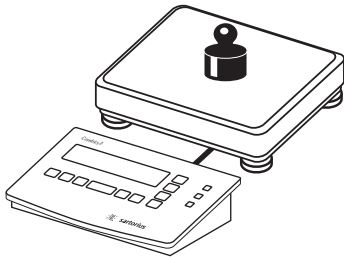

Place a load of unknown weight on the weighing instrument



If the weight is under the lower tolerance limit, LL is shown in the tolerance limit display (load is too light) (the weight display shows the measured weight value)



If the weight is within the tolerance range (in this example, 103.2 g), the weight value is displayed



If the weight is over the upper tolerance limit, HH is shown in the tolerance limit display (load is too heavy) (the weight display shows the measured weight value)



Print results

ACE HARDWARE		GOETTINGEN	
19.03.2002		15:43	
Setp	+	100.0	g
Min	+	95.0	g
Max	+	105.0	g
G#	+	103.2	g
T	+	0.0	g
N	+	103.2	g
Lim	+	3.20	%
W.Diff+		3.2	g

Printout

Target value
Minimum
Maximum

Gross weight
Tare weight
Net weight

Percentage of deviation from target*
Absolute difference from target

* In Tolerance Limit display mode:
If the weight is lighter than the target, the display shows: **S t a t** **LL**
If the weight is heavier than the target, the display shows: **S t a t** **HH**

Classification $\frac{\%}{\text{L}}$ L

With the Classification application, you can determine whether the weight of a given sample lies within the limits of a defined weight class.

Features:

- Configure 3 or 5 classes (menu item 4.8)
- Define contiguous classes
- Define classes that cover the entire weighing range of the weighing instrument
- Range below the specified minimum load is designated "Class 0"
- Define the upper limit of a given class by storing weight on weighing instrument or by entering a weight value and a percentage
- Show the current weight in the main display as a weight value or as belonging to a certain class
- Class of current weight also indicated by 1 LED (when using 3 classes) or 2 LEDs (when using 5 classes) 2 LEDs (when using 5 classes)
- Toggle the display between weight and class by pressing S .
- Digital input/output interface
- Info mode for display of class limits by pressing S (> 2 sec)

To use the Classification application, you need to enter the delimiters that separate one class from another.

- Start the initialization by pressing OK . The lower limit of Class 1 is defined by the preset minimum load. Weight values below minimum load are classified as belonging to Class 0, in part to prevent an unloaded weighing instrument from displaying a value that designates a class.

You can enter the other class delimiters as absolute values or percentages (menu item 4.9).

- Entering the class delimiters as absolute values (weighed values) (menu item 4.9.1):
For each upper limit (except that of the highest class), place a load on the weighing instrument and press OK to store it as the upper limit of a class. The bar graph and the numeric display show the limit currently being configured.
Each time you store a value for an upper limit, a check is run to make sure the value is equal to or greater than the upper limit of the previous class. If the value is invalid, an acoustic signal is emitted; the limit must be entered again.
- Entering delimiters as percentages (menu item 4.9.2):
Define the upper limit of Class 1 by placing the corresponding weight on the weighing instrument and pressing OK . The value is equal to 100 %. The upper limit of Class 2 is equal to 100 % plus the percentage you select by pressing REF (1, 2, 5, 10, 15, 30, 50, 70, 100, 150, 199 %).
Example: A load of 100 g is stored from the weighing instrument as the upper limit of Class 1. The value 15% is then entered, defining the upper limit of Class 2 as 115 g.
In this case, the weight ranges when working with 5 classes are:
Class 0: up to the minimum load
Class 1: Minimum load – 100 g
Class 2: 100 g – 115 g
Class 3: 115 g – 130 g
Class 4: 130 g – 145 g
Class 5: 145 g – maximum capacity

Before a new initialization, the previous initialization values must be deleted by pressing CF .

- Tare function:
 - 1) If you store a tare (weight value) by pressing the T key, you can later enter a tare value manually. The tare value you enter is added to the stored tare value.
Setting: menu code 3.25.1 (factory default)
 - 2) A tare value entered manually overwrites a stored tare value (weight value). If you enter a tare value manually, a tare value (weight value) stored later overwrites the manually entered value.
Setting: menu code 3.25.2
Operating menu setting:
 $\text{APPL} : \frac{\%}{\text{L}}$ $\text{L} : 3.25.$

Application Parameters: Classification









- 3. 5. Minimum Load for Automatic Taring and Automatic Printing
 - 3. 5. 1 * 1 digit
 - 3. 5. 2 2 digits
 - 3. 5. 3 5 digits
 - 3. 5. 4 10 digits
 - 3. 5. 5 20 digits
 - 3. 5. 6 50 digits
 - 3. 5. 7 100 digits
 - 3. 5. 8 200 digits
 - 3. 5. 9 500 digits
 - 3. 5.10 1000 digits
- 3. 6. Minimum Load for Initialization and Defining the Class 1 Lower Limit
 - 3. 6. 1 * 1 digit
 - 3. 6. 2 2 digits
 - 3. 6. 3 5 digits
 - 3. 6. 4 10 digits
 - 3. 6. 5 20 digits
 - 3. 6. 6 50 digits
 - 3. 6. 7 100 digits
 - 3. 6. 8 200 digits
 - 3. 6. 9 500 digits
 - 3. 6.10 1000 digits
- 3. 7. Automatic Taring: 1st Weight Tared
 - 3. 7. 1 * Off
 - 3. 7. 2 On
- 3. 8. Start Application with Most Recent Application Data when Combs is Switched On
 - 3. 8. 1 Automatic (on)
 - 3. 8. 2 * Manual (off)
- 3.25. Tare function
 - 3.25. 1* The tare value entered is added to the stored tare value
 - 3.25. 2 Overwritable tare value
- 4. 3. Activate Control Line for "Set" as:
 - 4. 3. 1 * "Set" output
 - 4. 3. 2 Ready to operate (for process control systems)
- 4. 7. Activation of Outputs
 - 4. 7. 1 Off
 - 4. 7. 2 Always active
 - 4. 7. 3 * Active at stability
- 4. 8. Number of Classes
 - 4. 8. 1 * 3 classes
 - 4. 8. 2 5 classes
- 4. 9. Parameter Input
 - 4. 9. 1 * Weight values
 - 4. 9. 2 Percentage
- 4.10. Automatic Printing
 - 4.10. 1* Off
 - 4.10. 2 On

Minimum Load for Initialization and Defining the Class 1 Lower Limit

The minimum load defines the lower limit for Class 1 (i.e., the delimiter between Classes 0 and 1). The application can only be initialized (to define the upper limit of Class 1) when the load on the weighing instrument exceeds the minimum load.

Display

The result of a given measurement is shown as either a weight value or the class number. You can toggle between these two display modes by pressing .

- Weight display; 3 classes:
The current weight is shown in the display; for example: 108.7 g
Class 1 Bar graph:  Numeric display: 1 LED: red is lit
Class 2 Bar graph:  Numeric display: 2 LED: green is lit
Class 3 Bar graph:  Numeric display: 3 LED: yellow is lit
- Weight display; 5 classes
The current weight is shown in the display; for example: 108.7 g
Class 1 Bar graph:  Numeric display: 1 LED: red is lit
Class 2 Bar graph:  Numeric display: 2 LED: red and green are lit
Class 3 Bar graph:  Numeric display: 3 LED: green is lit
Class 4 Bar graph:  Numeric display: 4 LED: green and yellow are lit
Class 5 Bar graph:  Numeric display: 5 LED: yellow is lit
- Class display; 3 classes
The current class is shown in the display; for example: CLASS 1 and the bar graph indicates the current weight. The LEDs are lit as for the weight display described above.
- Class display; 5 classes
The current class is shown in the display; for example: CLASS 1, and the bar graph indicates the current weight. The LEDs are lit as for the weight display described above.

Digital Input/Output Interface

The Classification application supports the digital input/output-interface. There are 4 control lines, or outputs, which are activated as follows (also refer to the diagram):

- Lighter
 - Equal
 - Heavier
 - Set
- The "Set" line usually indicates that the minimum load is exceeded. Alternatively, you can assign the "Ready-for-use" function to this port.

- Under menu item 4.7, you can define whether these control ports are
- inactive (4.7.1),
 - always active (4.7.2), or
 - active at stability (4.7.3).
- This makes it possible, for example, to connect a simple indicator for weighing or calculation results, similar to the 3-segment checkweighing display on the Combics, or control an automatic process.

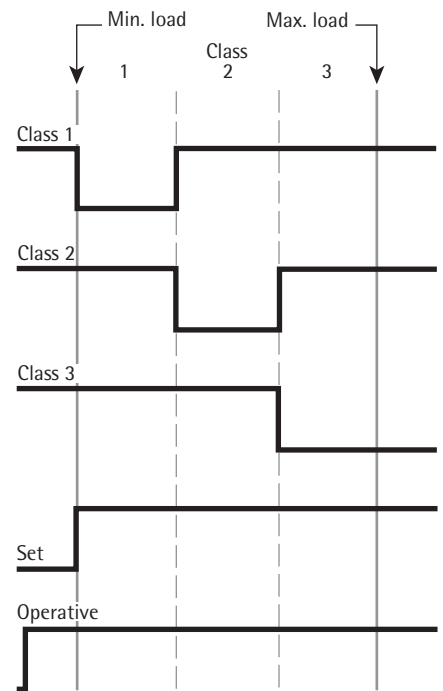

Digital I/O Interface
Control lines when working with 3 classes

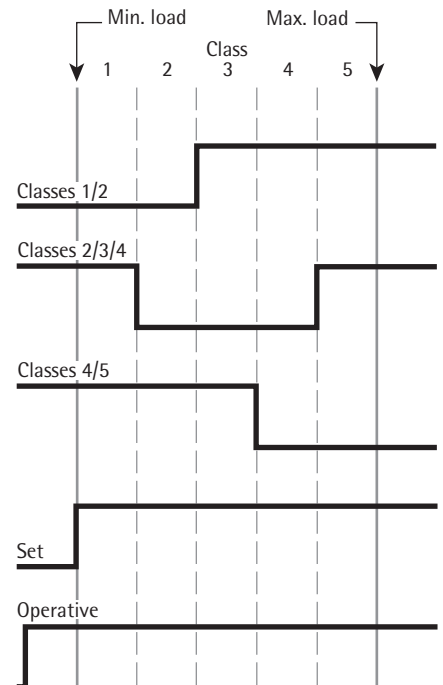

Digital I/O Interface
Control lines when working with 5 classes

Example:

Initialize the Classification application by taking over weighed values (menu item 4.9.1) to define 3 classes (menu item 4.81.)

CF

Delete any existing initialization data



OK

Begin initialization



The minus sign of the bar graph flashes to prompt the weight for the upper limit of the first class. A "1" is shown in the numeric display.

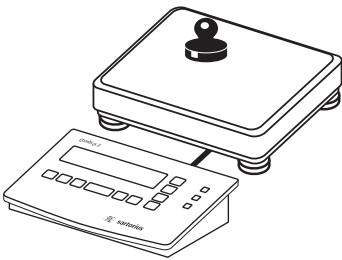

Place the weight for the upper limit of the first class on the weighing instrument (in this example, 10.0 g)



OK

Store the weight value as the upper limit for the first class



The middle segments of the bar graph flash to prompt the placement of the weight for the upper limit of the second class on the weighing instrument. A "2" is shown in the numeric display.

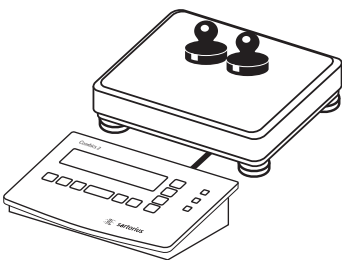

Place the weight for the upper limit of the second class on the weighing instrument (in this example, 20.0 g)



OK



Optional:  < 2 sec.



Optional: 

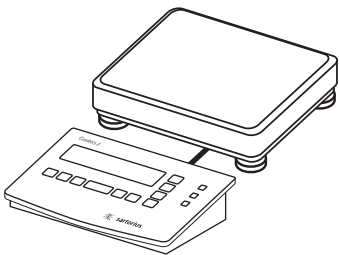

Store the weight value as the upper limit for the second class

When initialization is complete, the display shows the class to which the weight on the weighing instrument belongs.

Toggle to Info mode to view stored values

Upper limit of Class 1 is displayed

Toggle to the next display mode

Upper limit of Class 2 is displayed

Exit the Info mode

Unload weighing instrument

Example:
Determine the class of a given weight

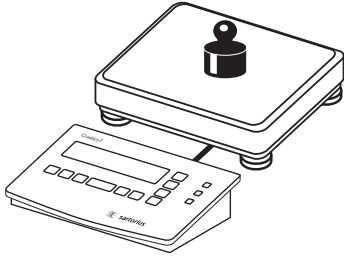

Place a load of unknown weight on the weighing instrument

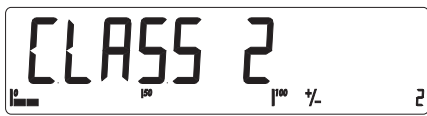

The display shows which class the weight falls into; in this example, Class 2 (10 g – 20 g)



Toggle display to weight readout



The weight of the load is shown (in this example, 17.3 g)



Print results

```

      PET STORE
      GOETTINGEN
05.03.2002      09:43
-----
Lim1  +      10.0 g
Lim2  +      20.0 g

G#    +      17.3 g
T     +       0.0 g
N     +      17.3 g

Class      2
-----
    
```

Printout

Upper limit, Class 1
Upper limit, Class 2



Gross weight
Tare weight
Net weight

Weight class

Weighing in Percent %

With the Weighing in Percent application, you can use your weighing instrument to obtain weight readouts in percent which are in proportion to a reference weight. The % symbol is displayed as the weight unit.

Features:

- Store the weight on the weighing instrument as reference weight
- Enter reference weight using a bar code scanner
- Enter tare weight using a bar code scanner
- Toggle the display between percentage and weight by pressing 
- Show percentage as loss or residue
- Display up to 3 decimal places
- Info mode for display of reference weight by pressing  (> 2 sec)

To determine the weight of a sample relative to a reference weight, you must enter the reference weight in the weighing instrument. There are 2 ways to do this with the Combics:

- By placing the amount of reference material on the weighing instrument specified by the reference percentage and pressing  to calculate the average and store the value.

The reference percentage is shown in the numeric display, and can be changed by pressing .

How the reference weight is calculated depends on the menu setting for resolution (3.9). Either the value is rounded off in accordance with the display resolution, or the display resolution is increased 10-fold (+1 decimal place) or 100-fold (+2 decimal places), or maximum internal resolution is applied.

- By entering the reference weight (i.e., the weight of 100%) using a bar code scanner (menu setting: "Setup> Bar code > Store value as reference (REF)"). In this case, the value is stored as a reference automatically, without pressing the  key.

This value remains active in the reference memory until you delete it by pressing , overwrite it or until you select a different application. It also remains stored after you switch off the Combics.

- Tare function:
 - 1) If you store a tare (weight value) by pressing the  key, you can later enter a tare value manually. The tare value you enter is added to the stored tare value.
Setting: menu code 3.25.1 (factory default)
 - 2) A tare value entered manually overwrites a stored tare value (weight value). If you enter a tare value manually, a tare value (weight value) stored later overwrites the manually entered value.
Setting: menu code 3.25.2
Operating menu setting:
APPL : % : 3.25.

Application Parameters: Weighing in Percent

- 3. 5. Minimum Load for Automatic Taring and Automatic Printing
 - 3. 5. 1 * 1 digit
 - 3. 5. 2 2 digits
 - 3. 5. 3 5 digits
 - 3. 5. 4 10 digits
 - 3. 5. 5 20 digits
 - 3. 5. 6 50 digits
 - 3. 5. 7 100 digits
 - 3. 5. 8 200 digits
 - 3. 5. 9 500 digits
 - 3. 5. 10 1000 digits
- 3. 6. Minimum Load for Initialization
 - 3. 6. 1 * 1 digit
 - 3. 6. 2 2 digits
 - 3. 6. 3 5 digits
 - 3. 6. 4 10 digits
 - 3. 6. 5 20 digits
 - 3. 6. 6 50 digits
 - 3. 6. 7 100 digits
 - 3. 6. 8 200 digits
 - 3. 6. 9 500 digits
 - 3. 6. 10 1000 digits
- 3. 7. Automatic Taring: 1st Weight Tared
 - 3. 7. 1 * Off
 - 3. 7. 2 On
- 3. 8. Start Application with Most Recent Application Data when Combics is Switched On
 - 3. 8. 1 Automatic (on)
 - 3. 8. 2 * Manual (off)
- 3. 9. Resolution for Calculation of Reference Value
 - 3. 9. 1 * Display resolution
 - 3. 9. 2 Display resolution +1 decimal place
 - 3. 9. 3 Display resolution +2 decimal places
 - 3. 9. 4 Internal resolution
- 3.10. Decimal Places for Display of Results
 - 3.10. 1 * None
 - 3.10. 2 1 decimal place
 - 3.10. 3 2 decimal places
 - 3.10. 4 3 decimal places
- 3.11. Storage Parameter
 - 3.11. 1 * At stability
 - 3.11. 2 At increased stability
- 3.13. Reference Weighing Instrument
 - 3.13. 1 * No reference instrument selected
 - 3.13. 2 WP1
 - 3.13. 3 WP2
- 3.15. Display of calculated value
 - 3.15. 1 * Residue
 - 3.15. 2 Loss
- 3.25. Tare function
 - 3.25. 1 * The tare value entered is added to the stored tare value
 - 3.25. 2 Overwritable tare value

Storage Parameter

The reference weight is saved when the weighing instrument has stabilized. “Stability” is defined as the point at which fluctuation of a measured value lies within a defined tolerance range. The narrower the tolerance range, the more stable the weighing instrument is at stability. This setting is also applied when you zero the weighing instrument.

Under menu item 3.11 you can determine whether the value is saved “At stability” (normal tolerance range) or “At increased stability” (narrower tolerance range).

If you select “At increased stability,” the reference weight stored will be more accurate and the results more reproducible, but the response time of the weighing instrument might be longer.

Minimum Load for Initialization

The minimum load for initialization is configured under menu item 3.6.

If the load exceeds this limit, the weighing instrument can be initialized. If the load is too light, the following will occur when you try to save a value:

- The error code *inF 29* is displayed
- A warning signal is emitted (double-beep)
- The weighing instrument is not initialized
- The preset reference percentage is stored

Weighing in Percent with Two Weighing Instruments

You can use two weighing instruments simultaneously with the Weighing in Percent application. When using two instruments, you can choose from the following operating modes:

- Weighing in Percent with two equivalent weighing instruments
- Weighing in Percent with one reference weighing instrument and one weighing platform

Weighing in Percent with Two Equivalent Weighing Instruments

Use this mode when samples of widely varying weight are measured at one workstation. Measure the lighter-weight pieces on one weighing instrument and the heavier pieces on another.

When you press $\frac{AVA}{AVA}$ to toggle from one weighing instrument to the other, the application is re-initialized.

You can define which of the two weighing instruments is active in the display when the Combics is switched on (menu item 8.11). This is the first weighing instrument active when you switch on the Combics, regardless of the setting for automatic initialization of the Weighing in Percent application.

Weighing in Percent with One Reference Weighing Instrument and One Weighing Platform

In this mode, a high resolution weighing instrument with a relatively low maximum capacity is used as a reference weighing instrument. The measuring platform has a high capacity, but a relatively low resolution.

This allows you to both determine the reference value with high resolution; i.e., very precisely, and to measure large samples, without requiring an expensive high-resolution, high-capacity weighing platform.

Specify which weighing instrument is the reference instrument under menu item 3.13. The system toggles automatically to the reference instrument for initialization (*rEF* is shown in the main display). Following initialization, the system toggles to the measuring platform.

Display

With the Weighing in Percent application, the result can be displayed as a remainder or loss. This is configured in Setup under menu item 3.15.

Equations:

$$\text{Residue} = \frac{\text{Current weight}}{100\% \text{ weight}} * 100$$

$$\text{Loss} = \frac{(\text{Current weight} - 100\% \text{ weight})}{100\% \text{ weight}} * 100$$

Example:

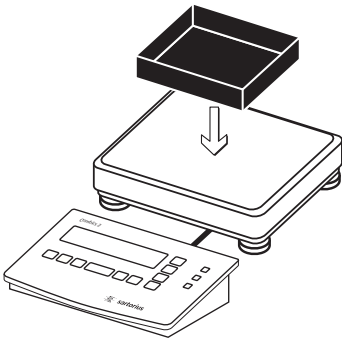

Place empty container on the weighing instrument



Tare the weighing instrument



REF (repeatedly, if necessary)

Set the desired percentage (in this example, 50%)

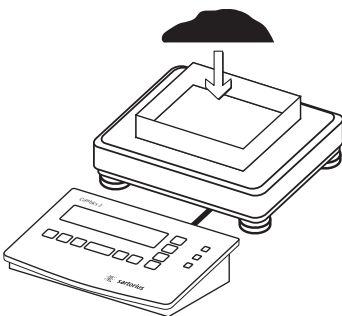

Place reference material corresponding to the reference percentage in the container



Confirm the reference weight



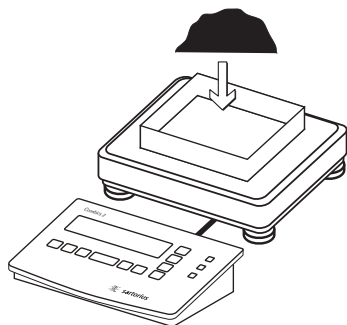

Remove the reference material and place the sample to be measured on the weighing instrument



The percentage of the reference weight equal to the sample is displayed



Print results

G#	+	641.2 g
T	+	200.0 g
N	+	441.2 g

Prc	+	21.00 %

Residue

G#	+	641.2 g
T	+	200.0 g
N	+	441.2 g

D	-	79.00 %

Loss

Averaging (Animal Weighing)

With the Averaging application, you can use your weighing instrument for calculating weights as the average of a number of individual weighing operations. These individual operations are also known as “subweighing operations.”

This function is used to determine weights under unstable ambient conditions or for weighing unstable samples (such as live animals).

Features:

- Averaging started manually or automatically
- Press the **[REF]** key to select the desired number of subweighing operations
- Toggle the display between last result and current weight by pressing **[S]**

A number of subweighing operations are required to form the basis for calculation of an average weight. These are performed consecutively as soon as the weight of one sample differs from that of the previous sample by less than the preset deviation.

The value for this deviation is entered in the Application settings (3.19) as a percentage. This value and the minimum load must be reached to start the averaging routine.

Whether averaging starts automatically or manually is defined under menu item 3.18.

There are four modes for calculating average weights:

- Manual start with preset number of subweighing operations
To use this mode, place the sample or animal on the weighing instrument and press **[OK]**.
- Manual start with the number of subweighing operations entered manually
To use this mode, place the sample/animal on the weighing instrument, press **[REF]** to enter the number of subweighing operations (10, 20, 30, 40) and then press **[OK]**.
- Automatic start with preset number of subweighing operations
The subweighing operations begin when the weight of the sample/animal on the weighing instrument exceeds the minimum load.

- Automatic start with the number of subweighing operations entered manually
To use this mode, press **[REF]** and enter the number of subweighing operations before placing the sample or animal on the weighing instrument. The subweighing operations begin when the weight of the sample/animal on the weighing instrument exceeds the minimum load.

If the “automatic tare” function is configured, the weight of the first load is stored as the tare value, and averaging begins only when the second load is placed on the weighing instrument (provided this weight exceeds the preset minimum load).

Minimum Load for Automatic Start

The minimum load for automatic start is configured under menu item 3.6. If the load exceeds this limit, the averaging routine can begin.

Display

A calculated average value is shown continuously on the main display. The symbol  is displayed. Press **[S]** to toggle the display between this result and the current weight value.

If the menu setting “Display is static until unload threshold reached” (3.21.1) is active, the program returns to the weight display automatically when the weighing instrument is unloaded; i.e., when the load is less than half the minimum load. The result of the most recent averaging operation is not stored. If the menu setting “Display is static until **[CF]** is pressed” (3.21.2) is active, the average weight remains on the weight display after the weighing instrument is unloaded, until the **[CF]** key is pressed or until a new measurement series is started, whether manually or automatically.

- Tare function:
 - 1) If you store a tare (weight value) by pressing the **[T←]** key, you can later enter a tare value manually. The tare value you enter is added to the stored tare value.
Setting: menu code 3.25.1 (factory default)
 - 2) A tare value entered manually overwrites a stored tare value (weight value). If you enter a tare value manually, a tare value (weight value) stored later overwrites the manually entered value.
Setting: menu code 3.25.2
Operating menu setting:
APPL :  : 3.25.

Application Parameters: Averaging (Animal Weighing)

3. 5.	Minimum Load for Automatic Taring and Automatic Printing
3. 5. 1 *	1 digit
3. 5. 2	2 digits
3. 5. 3	5 digits
3. 5. 4	10 digits
3. 5. 5	20 digits
3. 5. 6	50 digits
3. 5. 7	100 digits
3. 5. 8	200 digits
3. 5. 9	500 digits
3. 5.10	1000 digits
3. 6.	Minimum Load
3. 6. 1 *	1 digit
3. 6. 2	2 digits
3. 6. 3	5 digits
3. 6. 4	10 digits
3. 6. 5	20 digits
3. 6. 6	50 digits
3. 6. 7	100 digits
3. 6. 8	200 digits
3. 6. 9	500 digits
3. 6.10	1000 digits
3. 7.	Automatic Taring: 1st Weight Tared
3. 7. 1 *	Off
3. 7. 2	On
3. 8.	Start Application with Most Recent Application Data when Combs is Switched On
3. 8. 1	Automatic (on)
3. 8. 2 *	Manual (off)
3.18.	Start of Averaging Routine
3.18. 1*	Manual
3.18. 2	Automatic
3.19.	Animal Activity
3.19. 1	0.1 % of the animal/object
3.19. 2*	0.2% of the animal/object
3.19. 3	0.5 % of the animal/object
3.19. 4	1% of the animal/object
3.19. 5	2% of the animal/object
3.19. 6	5% of the animal/object
3.19. 7	10% of the animal/object
3.19. 8	20% of the animal/object
3.19. 9	50% of the animal/object
3.19.10	100 % of the animal/object
3.20.	Automatic Printout of Results
3.20. 1*	Off
3.20. 2	On
3.21.	Static Display After Load Removed
3.21. 1*	Display is static until unload threshold reached
3.21. 2	Display is static until [CF] is pressed
3.25.	Tare function
3.25. 1*	The tare value entered is added to the stored tare value
3.25. 2	Overwritable tare value

Example:

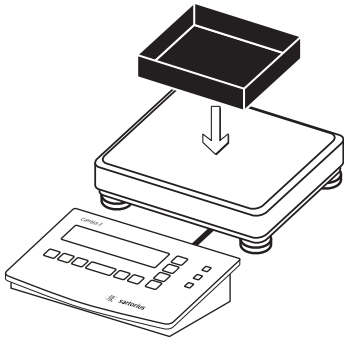

Place empty container on the weighing instrument



Tare the weighing instrument



Set the desired number of measurements (in this example, 20)

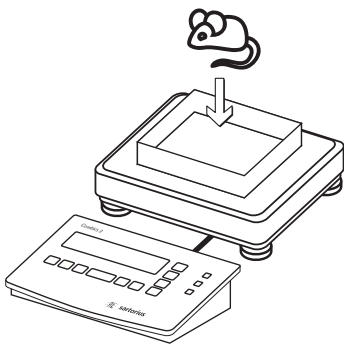

Place 1st animal in bowl



Start measurement



Measurement starts as soon as all criteria are met. The number of subweighing operations remaining is shown in the numeric display.



At the conclusion of the series, the calculated mean value is displayed with the Δ symbol.



Print results

x-Net + 24.6 g

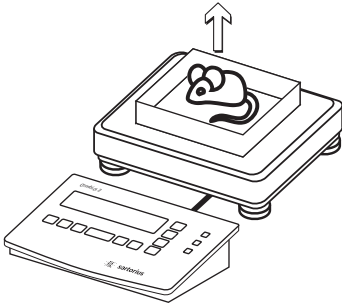

Unload weighing instrument





Once the weighing instrument is unloaded (i.e., the load = less than 1/2 the minimum load), the current weight value is displayed.



Net-Total Formulation

When the Net-Total Formulation application is selected, you can weigh in different components up to a defined total. Each component is saved in the net-total memory. You can print out both the total weight and the individual weights of the components.

Features:

- Weigh in up to 199 components in series
- Current component number shown in the numeric display (indicating the component to be added)
- Toggle the display between “component mode” and “additive mode” by pressing :
 - Component mode: Display the weight of the component currently on the instrument (for 1 second after it is saved; then the instrument is tared)
 - Additive mode: Display the weight of all components on the instrument (after it is saved, the net weight of the last component added is displayed briefly)
- Toggle to a second weighing instrument while weighing on the first
- Automatic printout of component or total weight when weight is saved
- Automatic taring of container weight
- Minimum load for automatic taring
- Minimum load for storing values
- Display the value in totalizing memory in the Info mode, accurately calculated in the active weight unit, by pressing and holding 

Application Parameters: Net-Total Formulation



3. 5.	Minimum Load for Automatic Taring and Automatic Printing
3. 5. 1 *	1 digit
3. 5. 2	2 digits
3. 5. 3	5 digits
3. 5. 4	10 digits
3. 5. 5	20 digits
3. 5. 6	50 digits
3. 5. 7	100 digits
3. 5. 8	200 digits
3. 5. 9	500 digits
3. 5.10	1000 digits
3. 6.	Minimum Load for Automatic Storage/Transfer of Values
3. 6. 1 *	1 digit
3. 6. 2	2 digits
3. 6. 3	5 digits
3. 6. 4	10 digits
3. 6. 5	20 digits
3. 6. 6	50 digits
3. 6. 7	100 digits
3. 6. 8	200 digits
3. 6. 9	500 digits
3. 6.10	1000 digits
3. 7.	Automatic Taring: 1st Weight Tared
3. 7. 1 *	Off
3. 7. 2	On
3.17.	Automatic Individual or Component Printout when Value Stored
3.17. 1	Off
3.17. 2*	Generate printout with complete standard configuration each time  is pressed
3.17. 3	Generate printout with complete standard configuration only once when  is pressed

Minimum Load for Automatic Storage/Transfer of Values

The minimum load for automatic storage or transfer of weight values is configured under menu item 3.6. If the load exceeds this limit, the weight currently displayed can be stored in net-total memory.

Net-Total Formulation with Two Weighing Instruments

This mode is used for weighing large and small components at the same time.

In this mode, you can toggle from the small-component instrument to the large-component instrument during measurement. Once you toggle to the large-component instrument, the  and  keys are available until a component is value is saved. For example, you can tare a partially-filled container taken from the small-component instrument on the large component instrument.

The value in component memory on the small-component instrument is transferred to the large-component instrument and the weight unit is converted, if necessary. The Component and Additive display modes are both available on the large-component instrument.

The value read by the active instrument is saved in component memory. The displayed result is accurately calculated in the active weight unit, for example:

$$\begin{aligned}
 &1243 \text{ g} \\
 &\text{(from an instrument with 1 interval)} \\
 + &1.40 \text{ kg} \\
 &\text{(from an instrument with 5 intervals)} \\
 = &2.643 \text{ kg (calculated result)}
 \end{aligned}$$

When you press  to stop a measurement series, the tare memories for both weighing instruments are cleared, unless the large-component instrument is in SBI mode, in which case the instrument is only tared.

Example:

Weigh in 3 components, display total weight after 2nd component (Additive mode)

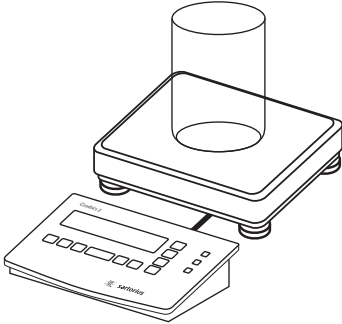

Place empty container on the weighing instrument



Container weight a prompt for first component are shown



Tare the weighing instrument

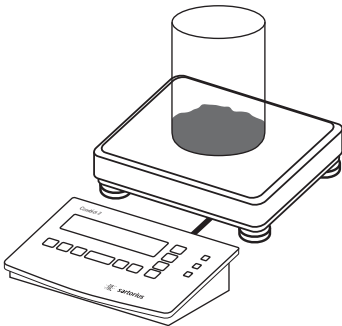

Add the first component (in this example, 68.3 g)



The weight of the first component is displayed



Store the weight of the first component

```
ACE HARDWARE
GOETTINGEN
20.02.2002    15:10
-----
Cmp001      68.3 g
```

Total data record is printed, as configured under menu item 7.7. or 7.8.
The header is printed only once

Component weight



The weighing instrument is tared automatically and the component counter value is increased by one (prompting the next component)

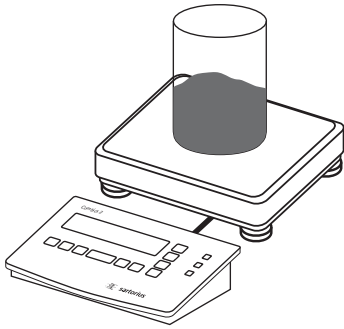

Add the second component (in this example, 82.7 g)



The weight of the second component is displayed

OK

Store the weight of the second component

Cmp002 82.7 g

Component weight is printed



The weighing instrument is tared automatically and the component counter value is increased by one (prompting the next component)

↶

Toggle to the Additive mode



The value displayed equals the weight of all components added up to now plus the current weight



Add the third component (bringing the total to the desired target)

OK

Store the weight of the third component

Cmp003 49.1 g

Component weight is printed

CF

End the weighing-in operation

Total data record is printed, as configured under 7.9. or 7.10.

```

Ser.no      12345678
n            3
S-Comp+    200.1 g
Cont.T+     50.0 g
-----
    
```

Serial number of the weighing instrument
 Number of components
 Content of component memory
 Content of tare memory (container weight)
 Dotted line

Totalizing Σ

With the Totalizing application, you can add weight values to the totalizing memory. The number of values added to the memory is also stored ("transaction counter").

Features:

- Weigh in up to 199 items
- Current transaction number displayed in the text line (indicating the items already added)
- Save weight values manually or automatically
- Accurate calculation of total of weight values from two weighing instruments
- Unfinished totalization stored in battery-backed memory
- Toggle the display between current weight and total value by pressing \square :
 - Totalizing mode: shows the value in totalizing memory plus the current weight; for filling to a defined total
- Automatic printout of component or total weight when weight is saved
- Automatic taring of container weight
- Minimum load for automatic tare
- Minimum load for storing values
- Press and hold \square to display the value in totalizing memory (net, gross) in the Info mode, accurately calculated in the active weight unit.

The Combics has a totalizing memory for adding individual net and gross values. There are two ways to store weight values in the totalizing memory:

- Manually, by pressing the \square key. The value is added to the value already stored, and the transaction counter value increases by one. When a value is added manually, the program does not check whether the weighing instrument has been unloaded since the last time the \square key was pressed.
- Automatically, when the weighing instrument has stabilized and the minimum load is exceeded (menu item 3.16.2). The weighing instrument is considered to be unloaded when the load is less than 50% of the minimum load (menu item 3.6).

The numeric display shows the transaction counter.

Press the \square key to clear the totalizing memory. A printout is generated automatically.

With the weighing instruments connected, you can add values from both instruments to the totalizing memory. The displayed result is accurately calculated in the active weight unit. Example: 1.243 kg (measured on a weighing instrument using 1 scale interval) added to 1.40 kg (measured on a weighing instrument using 5 scale intervals) is displayed as 2.643 kg.

- Tare function:
 - 1) If you store a tare (weight value) by pressing the \square key, you can later enter a tare value manually. The tare value you enter is added to the stored tare value. Setting: menu code 3.25.1 (factory default)
 - 2) A tare value entered manually overwrites a stored tare value (weight value). If you enter a tare value manually, a tare value (weight value) stored later overwrites the manually entered value. Setting: menu code 3.25.2
Operating menu setting:
APPL : Σ : 3.25.

Application Parameters: Totalizing

- 3. 5. Minimum Load for Automatic Taring and Automatic Printing
 - 3. 5. 1 * 1 digit
 - 3. 5. 2 2 digits
 - 3. 5. 3 5 digits
 - 3. 5. 4 10 digits
 - 3. 5. 5 20 digits
 - 3. 5. 6 50 digits
 - 3. 5. 7 100 digits
 - 3. 5. 8 200 digits
 - 3. 5. 9 500 digits
 - 3. 5.10 1000 digits
- 3. 6. Minimum Load for Automatic Storage/Transfer of Values
 - 3. 6. 1 * 1 digit
 - 3. 6. 2 2 digits
 - 3. 6. 3 5 digits
 - 3. 6. 4 10 digits
 - 3. 6. 5 20 digits
 - 3. 6. 6 50 digits
 - 3. 6. 7 100 digits
 - 3. 6. 8 200 digits
 - 3. 6. 9 500 digits
 - 3. 6.10 1000 digits
- 3. 7. Automatic Taring: 1st Weight Tared
 - 3. 7. 1 * Off
 - 3. 7. 2 On
- 3. 8. Start Application with Most Recent Application Data when Combics is Switched On
 - 3. 8. 1 Automatic (on)
 - 3. 8. 2 * Manual (off)
- 3.16. Automatic Storage/Transfer of Value
 - 3.16. 1* Off
 - 3.16. 2 On
- 3.17. Automatic Individual or Component Printout when Value Stored
 - 3.17. 1 Off
 - 3.17. 2* Generate printout with complete standard configuration each time \square is pressed
 - 3.17. 3 Generate printout with complete standard configuration only once when \square is pressed
- 3.25. Tare function
 - 3.25. 1* The tare value entered is added to the stored tare value
 - 3.25. 2 Overwritable tare value

Minimum Load for Automatic Storage/Transfer of Values

The minimum load for automatic storage or transfer of weight values is configured under menu item 3.6. Once the load on the weighing instrument exceeds the specified minimum, the measured value is stored or transferred automatically, if the operating menu is configured for automatic storage (menu item 3.16.2).

Display

Press **[S]** to toggle the display between the weight currently on the weighing instrument and the current weight value plus the value in totalizing memory.

Press and hold **[S]** (> 2 sec) to toggle to the Info mode. In the "Info" mode, the total of gross weight values is shown first. Press **[S]** again to show the net value.

Press the **[S]** key again to show the transaction counter in the main display.

Press **[S]** one more time to exit the Info mode.

To exit the "Info" mode earlier, press and hold **[S]** (> 2 sec).

Printout

Under menu item 3.17 you can configure whether a printout is generated manually, by pressing **[E]** (3.17.3), or automatically when a weight value is stored in the totalizing memory (3.17.2 or 3.17.3).

When you generate a printout manually by pressing **[E]**, the transaction counter value is not printed.

For automatic printouts, you can define whether a printout is generated after each individual transaction (3.17.2) or includes all totalized components (3.17.3).

Each printout starts with the header lines and the date and time, followed by a dotted line, before printing the gross, tare, net and transaction counter values.

The printout of components includes the header lines and date and time only on the first printout. Subsequent printouts include only the gross, tare, net and transaction counter values (and serial number, if configured).

The individual and component printouts are configured under menu items 7.7 and 7.8.

The total data record is printed when you clear the totalizing memory (by pressing the **[CF]** key).

The total data record includes data from the gross totalizing memory (*** G**), the net totalizing memory (*** N**), the total transaction count (**n**) and a dotted line.

The fields selected under menu items 7.9. and 7.10. are printed every time the **[CF]** key is pressed, regardless of whether individual or component printing is configured.

Example:

Totalizing weight values with printout of components

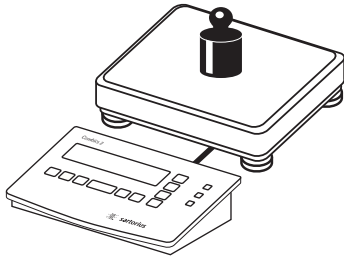

1. Place the sample on the weighing instrument



Weight value is displayed



Store weight value in totalizing memory



Main display: Current weight on the weighing instrument
Numeric display: Transaction counter (in this example: 1)

SARTORIUS		
GOETTINGEN		
06.02.2002		12:15

G#	+	102.9 g
T	+	0.0 g
N	+	102.9 g
n		1

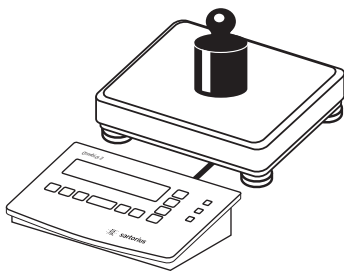

Unload the weighing instrument and then place the second sample on the instrument



Weight value is displayed



Toggle to Totalizing mode



Main display: Totalizing memory content plus current weight
Numeric display: Transaction counter (in this example: 1)



Store weight value in totalizing memory

SARTORIUS
 GOETTINGEN
 06.02.2002 12:19

G#	+	215.2	g
T	+	0.0	g
N	+	215.2	g
n		2	

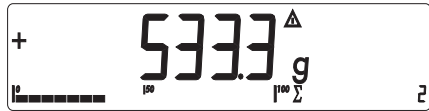

Main display: Totalizing memory content plus current weight
 Numeric display: Transaction counter (in this example: 2)

CF

End totalizing

Total data record is printed, as configured under 7.9. or 7.10.

*G	+	318.1	g
*N	+	318.1	g
n		2	

Number of components
 Contents of component memory
 Contents of tare memory (container weight)
 Dotted line

Configuration

Operating Menu Overview

You can configure the Combics to meet individual requirements by entering user data and setting selected parameters in the operating menu.

The operating menu is a combination of text levels and numeric codes.

- ////// = Setting/function available on Combics 1 plus only
- ▬ = Setting/function available on Combics 2 only
- ▬ = Setting/function available on Combics 1 plus and Combics 2 only

First level display 2nd level display Function

Menu

APPL		Select and configure application programs
	▬ ▴ ▾	Basic Weighing Function
	▬ ● ● ● ●	Counting
	▬ ● ● ● ● n n	Neutral Measurement
	▬ ● ● ● ●	Averaging (Animal Weighing)
	▬ +/-%	Checkweighing
	▬ +/-% CL	Classification
	▬ %	Weighing in Percent
	▬ ↓	Net-Total Formulation
	▬ Σ	Totalizing
Fn-FEY		Define the function of [Fn]
	▬ OFF	No function
	▬ Gross/net	Gross/net toggling
	▬ 2. unit	Show 2nd weight unit
	▬ RES 10	10-fold increased resolution
SETUP		Adapt Combics to user requirements
	▬ WP 1	Settings for weighing instrument on WP1
	▬ COM 1	Settings for the RS-232 interface
	▬ UNICOM	Settings for the optional second interface
	▬ CTRL IN	Set the function of the universal input (control line)
	▬ BARCODE	Set the bar code scanner function
	▬ PRTPRO	Settings for the printout
	▬ UT IL IT	Settings for additional functions
	▬ TIME	Set the time
	▬ DATE	Set the date
	▬ CODE	Enter a password to protect menu settings
INFO		View device-specific information (service date, serial number, etc.)
LANG		Select language for calibration, adjustment and GMP printouts
	▬ DEUTSCH	German
	▬ ENGLISH	English
	▬ US MODE	English with U.S. date/time format
	▬ FRANÇ	French
	▬ ITAL	Italian
	▬ ESPANOL	Spanish

Configuration

Example: Change language from “English” to “English with U.S. date/time format”



Switch on the Combics



While all segments are lit, press the key

First level of menu for selecting the application program *APPL* is shown



Select the *LANG* menu item (press repeatedly until *LANG* is displayed)



Select *LANG* device parameter

The currently active language is shown

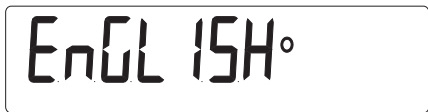

Select the *u.S. ModE* menu item

Press repeatedly until *u.S. ModE* is displayed)



Confirm this menu item

Return to menu level 2 to configure other menu settings, or



return to menu level 1 to configure other menu settings, or



exit the operating menu



Configuration

Example: Assign a password to protect the application program settings “APPL” and the device parameters “SEtUP” from unauthorized changes (in this example: AB2)



Switch on the Combics

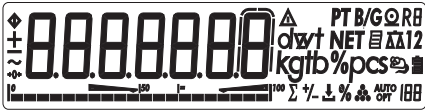

While all segments are lit, press the key



First level of menu for selecting the application program *APPL* is shown



Select the *SEtUP* menu item
(press repeatedly until *SEtUP* is displayed)



Open the *SEtUP* menu



Select the *CoDE* menu item
(Press repeatedly until *CoDE* is displayed)

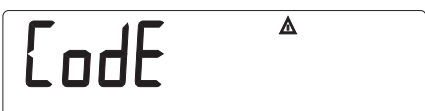

Open the password input menu item



Enter the first character using the and keys (in this example: *A*)



Store character

Configuration

A_

(F), (F), (F)

Ab

→T←

Ab_

Fn, Fn, Fn

Ab2

→T←

Ab2_

→T←

Code [▲]

→O←

→T← > 2 sec

◆ 0.0 g
|° 100 |100

Enter the second character using the (F) and (Fn) keys (in this example: b)

Store character

Enter the third character using the (F) and (Fn) keys (in this example: 2)

Store character

To enter other characters, use the (F) and (Fn) keys and press →T← to confirm

Store the password

Exit this menu level to configure other menu settings, or

Exit the operating menu

To delete a password:

Overwrite the old password with the new password, or enter a space as the password and press →T← to confirm.

Configuration

Operating Menu Overview (Parameters)

- ////// = Setting/function available on Combics 1 plus only
- ▬ = Setting/function available on Combics 2 only
- = Setting/function available on Combics 1 plus and Combics 2 only

* Factory setting

Menu

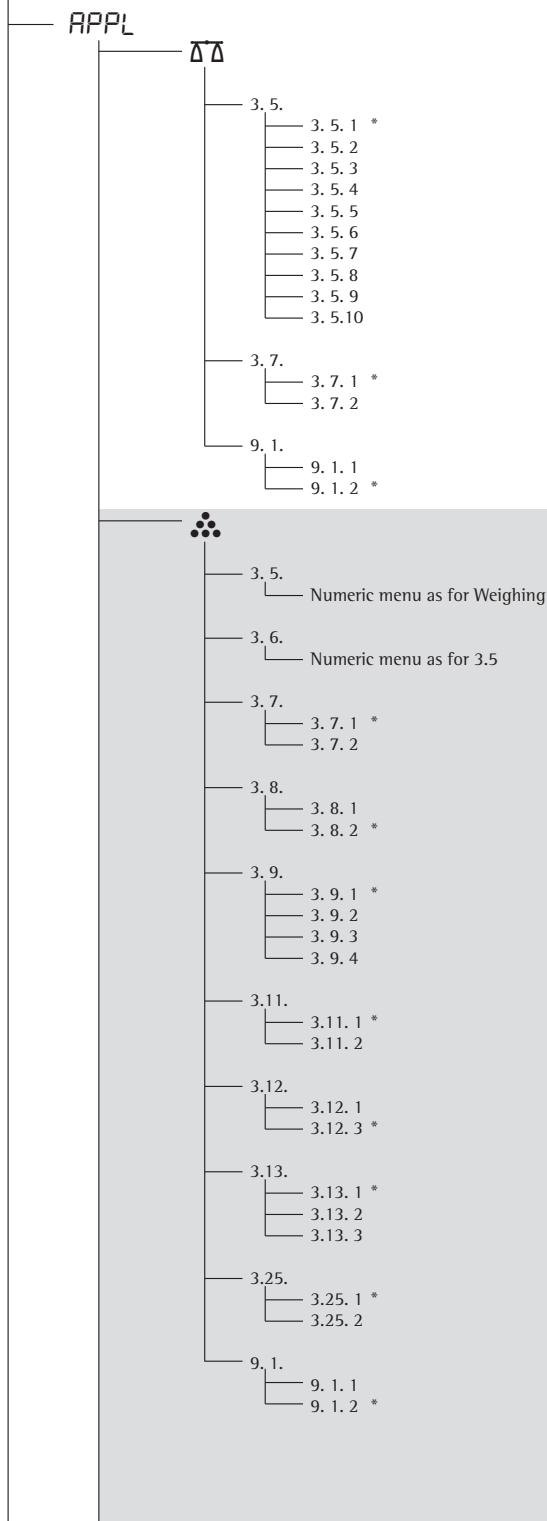

Application Programs

Basic Weighing Function

- Minimum Load for Automatic Taring and Automatic Printing
- 1 digit
 - 2 digits
 - 5 digits
 - 10 digits
 - 20 digits
 - 50 digits
 - 100 digits
 - 200 digits
 - 500 digits
 - 1000 digits

- Automatic Taring: 1st Weight Tared
- Off
 - On

- Factory Settings for All Application Programs
- Yes
 - No

Counting

- Minimum Load for Automatic Taring and Automatic Printing

- Minimum Load for Initialization

- Automatic Taring: 1st Weight Tared
- Off
 - On

- Start Application with Most Recent Application Data when Combics is Switched On
- Automatic (on)
 - Manual (off)

- Resolution for Calculation of Reference Value
- Display resolution
 - Display resolution + 1 decimal place
 - Display resolution + 2 decimal places
 - Internal resolution

- Storage Parameter
- At stability
 - At increased stability

- Reference Sample Updating
- Off
 - Automatic

- Reference Weighing Instrument
- No reference instrument selected
 - WP1
 - WP2

- Tare function
- The tare value entered is added to the stored tare value
 - Overwritable tare value

- Factory Settings for All Application Programs
- Yes
 - No

Configuration

Menu Item	Description	Options
APPL		
3.5.	Numeric menu as for Weighing	Neutral Measurement
3.6.	Numeric menu as for Counting	Minimum Load for Automatic Taring and Automatic Printing
3.7.		Minimum Load for Initialization
3.7.1 *		Automatic Taring: 1st Weight Tared
3.7.2		Off
3.7.2		On
3.8.		Start Application with Most Recent Application Data when Combics is Switched On
3.8.1		Automatic (on)
3.8.2 *		Manual (off)
3.9.		Resolution for Calculation of Reference Value
3.9.1 *		Display resolution
3.9.2		Display resolution + 1 decimal place
3.9.3		Display resolution + 2 decimal places
3.9.4		Internal resolution
3.10.		Decimal Places for Display of Results
3.10.1 *		None
3.10.2		1 decimal place
3.10.3		2 decimal places
3.10.4		3 decimal places
3.11.		Storage Parameter
3.11.1 *		At stability
3.11.2		At increased stability
3.13.		Reference Weighing Instrument
3.13.1 *		Off
3.13.2		To weighing instrument WP1
3.13.3		To weighing instrument WP2
3.25.		Tare function
3.25.1 *		The tare value entered is added to the stored tare value
3.25.2		Overwritable tare value
9.1.		Factory Settings for All Application Programs
9.1.1		Yes
9.1.2 *		No
3.5.	Numeric menu as for Weighing	Minimum Load for Automatic Taring and Automatic Printing
3.6.	Numeric menu as for Counting	Minimum Load for Automatic Start
3.7.		Automatic Taring: 1st Weight Tared
3.7.1 *		Off
3.7.2		On
3.8.		Start Application with Most Recent Application Data when Combics is Switched On
3.8.1		Automatic (on)
3.8.2 *		Manual (off)
3.18.		Start of Averaging Routine
3.18.1 *		Manual
3.18.2		Automatic
3.19.		Animal Activity
3.19.1		0.1 % of the animal/object
3.19.2 *		0.2% of the animal/object
3.19.3		0.5 % of the animal/object
3.19.4		1% of the animal/object
3.19.5		2% of the animal/object
3.19.6		5% of the animal/object
3.19.7		10% of the animal/object
3.19.8		20% of the animal/object
3.19.9		50% of the animal/object
3.19.10		100 % of the animal/object
3.20.		Automatic Printout of Results
3.20.1 *		Off
3.20.2		On



- 3.21.
 - 3.21.1 *
 - 3.21.2
- 3.25.
 - 3.25.1 *
 - 3.25.2
- 9.1.
 - 9.1.1
 - 9.1.2 *

Static Display After Load Removed
 Display is static until unload threshold reached
 Display is static until **[CF]** is pressed

Tare function
 The tare value entered is added to the stored tare value
 Overwritable tare value

Factory Settings for All Application Programs
 Yes
 No



- 3.5.
 - Numeric menu as for Weighing
- 3.7.
 - 3.7.1 *
 - 3.7.2
- 3.8.
 - 3.8.1
 - 3.8.2 *
- 3.25.
 - 3.25.1 *
 - 3.25.2
- 4.2.
 - 4.2.1 *
 - 4.2.2
- 4.3.
 - 4.3.1 *
 - 4.3.2
- 4.4.
 - 4.4.1
 - 4.4.2
 - 4.4.3
 - 4.4.4 *
 - 4.4.5
- 4.5.
 - 4.5.1 *
 - 4.5.2
- 4.6.
 - 4.6.1 *
 - 4.6.2
 - 4.6.3
 - 4.6.4
- 9.1.
 - 9.1.1
 - 9.1.2 *

Checkweighing

Minimum Load for Automatic Taring and Automatic Printing

Automatic Taring: 1st Weight Tared
 Off
 On

Start Application with Most Recent Application Data when Combics is Switched On
 Automatic (on)
 Manual (off)

Tare function
 The tare value entered is added to the stored tare value
 Overwritable tare value

Check Range
 30% to 170%
 10% to infinity

Activate Control Line for "Set" as:
 "Set" output
 Ready to operate (for process control systems)

Activation of Outputs
 Off
 Always active
 Active at stability
 Active within check range
 Active at stability within the check range

Parameter Input
 Min, max, target
 Only target with percent limits

Automatic Printing
 Off
 On
 Only values within tolerance
 Only values outside tolerance

Factory Settings for All Application Programs
 Yes
 No



- 3.5.
 - Numeric menu as for weighing
- 3.6.
 - Numeric menu as for Counting
- 3.7.
 - 3.7.1 *
 - 3.7.2
- 3.8.
 - 3.8.1
 - 3.8.2 *
- 3.25.
 - 3.25.1 *
 - 3.25.2

Classification

Minimum Load for Automatic Taring and Automatic Printing

Minimum Load for Initialization and Definition of "Class 1" Lower Limit

Automatic Taring: 1st Weight Tared
 Off
 On

Start Application with Most Recent Application Data when Combics is Switched On
 Automatic (on)
 Manual (off)

Tare function
 The tare value entered is added to the stored tare value
 Overwritable tare value

Configuration

APPL

+/- CL

- 4.3.
 - 4.3.1 *
 - 4.3.2

Activate Control Line for "Set" as:
 "Set" output
 Ready to operate

- 4.7.
 - 4.7.1
 - 4.7.2
 - 4.7.3 *

Activation of Outputs
 Off
 Always active
 Active at stability

- 4.8.
 - 4.8.1 *
 - 4.8.2

Number of Classes
 3 classes
 5 classes

- 4.9.
 - 4.9.1 *
 - 4.9.2

Parameter Input
 Weight values
 Percentage

- 4.10.
 - 4.10.1 *
 - 4.10.2

Automatic Printing
 Off
 On

- 9.1.
 - 9.1.1
 - 9.1.2 *

Factory Settings for All Application Programs
 Yes
 No

%

Weighing in Percent

- 3.5.
 - Numeric menu as for Weighing

Minimum Load Automatic Taring and Automatic Printing

- 3.6.
 - Numeric menu as for Counting

Minimum Load for Automatic Initialization

- 3.7.
 - 3.7.1 *
 - 3.7.2

Automatic Taring: 1st Weight Tared
 Off
 On

- 3.8.
 - 3.8.1
 - 3.8.2 *

Start Application with Most Recent Application Data when Combics is Switched On
 Automatic (on)
 Manual (off)

- 3.9.
 - 3.9.1 *
 - 3.9.2
 - 3.9.3
 - 3.9.4

Resolution for Calculation of Reference Value
 Display resolution
 Display resolution + 1 decimal place
 Display resolution + 2 decimal places
 Internal resolution

- 3.10.
 - 3.10.1 *
 - 3.10.2
 - 3.10.3
 - 3.10.4

Decimal Places for Display of Results
 None
 1 decimal place
 2 decimal places
 3 decimal places

- 3.11.
 - 3.11.1 *
 - 3.11.2

Storage Parameter
 At stability
 At increased stability

- 3.13.
 - 3.13.1 *
 - 3.13.2
 - 3.13.3

Reference Weighing Instrument
 Off
 To weighing instrument WP1
 To weighing instrument WP2

- 3.15.
 - 3.15.1 *
 - 3.15.2

Display of Calculated Value
 Residue
 Loss

- 3.25.
 - 3.25.1 *
 - 3.25.2

Tare function
 The tare value entered is added to the stored tare value
 Overwritable tare value

- 9.1.
 - 9.1.1
 - 9.1.2 *

Factory Settings for All Application Programs
 Yes
 No

APPL

- 3.5. Numeric menu as for Weighing
- 3.6. Numeric menu as for Counting
- 3.7.
 - 3.7.1 *
 - 3.7.2
- 3.17.
 - 3.17.1
 - 3.17.2 *
 - 3.17.3
- 9.1.
 - 9.1.1
 - 9.1.2 *

Net-Total Formulation (2nd Tare Memory)

Minimum Load Automatic Taring and Automatic Printing

Minimum Load for Automatic Storage/Transfer of Values

Automatic Taring: 1st Weight Tared

Off
On

Printout when Value is Stored in Totalizing Memory

Automatic printout of results: Off

Generate printout with complete standard configuration each time **OK** is pressed

Generate printout with complete standard configuration only once when **OK** is pressed

Factory Settings for All Application Programs

Yes
No

Totalizing

Minimum Load Automatic Taring and Automatic Printing

Minimum Load for Automatic Storage/Transfer of Values

Automatic Taring: 1st Weight Tared

Off
On

Start Application with Most Recent Application Data when Combics is Switched On

Automatic (on)
Manual (off)

Automatic Storage

Off
On

Printout when Value is Stored in Totalizing Memory

Automatic printout of results: Off

Individual of transaction by pressing **OK**

Print components of transaction by pressing **OK**

Tare function

The tare value entered is added to the stored tare value
Overwritable tare value

Factory Settings for All Application Programs

Yes
No

- 3.5. Numeric menu as for Weighing
- 3.6. Numeric menu as for Counting
- 3.7.
 - 3.7.1 *
 - 3.7.2
- 3.8.
 - 3.8.1
 - 3.8.2 *
- 3.16.
 - 3.16.1 *
 - 3.16.2
- 3.17.
 - 3.17.1
 - 3.17.2 *
 - 3.17.3
- 3.25.
 - 3.25.1 *
 - 3.25.2
- 9.1.
 - 9.1.1
 - 9.1.2 *

Key Assignment: **Fn**

No **Fn** key function

Gross/net toggling

Show 2nd unit

10-fold increased resolution. Display: max. 10 seconds

Fn-KEY

- OFF *
- Gross/Net
- 2. unit
- RES 10

Configuration

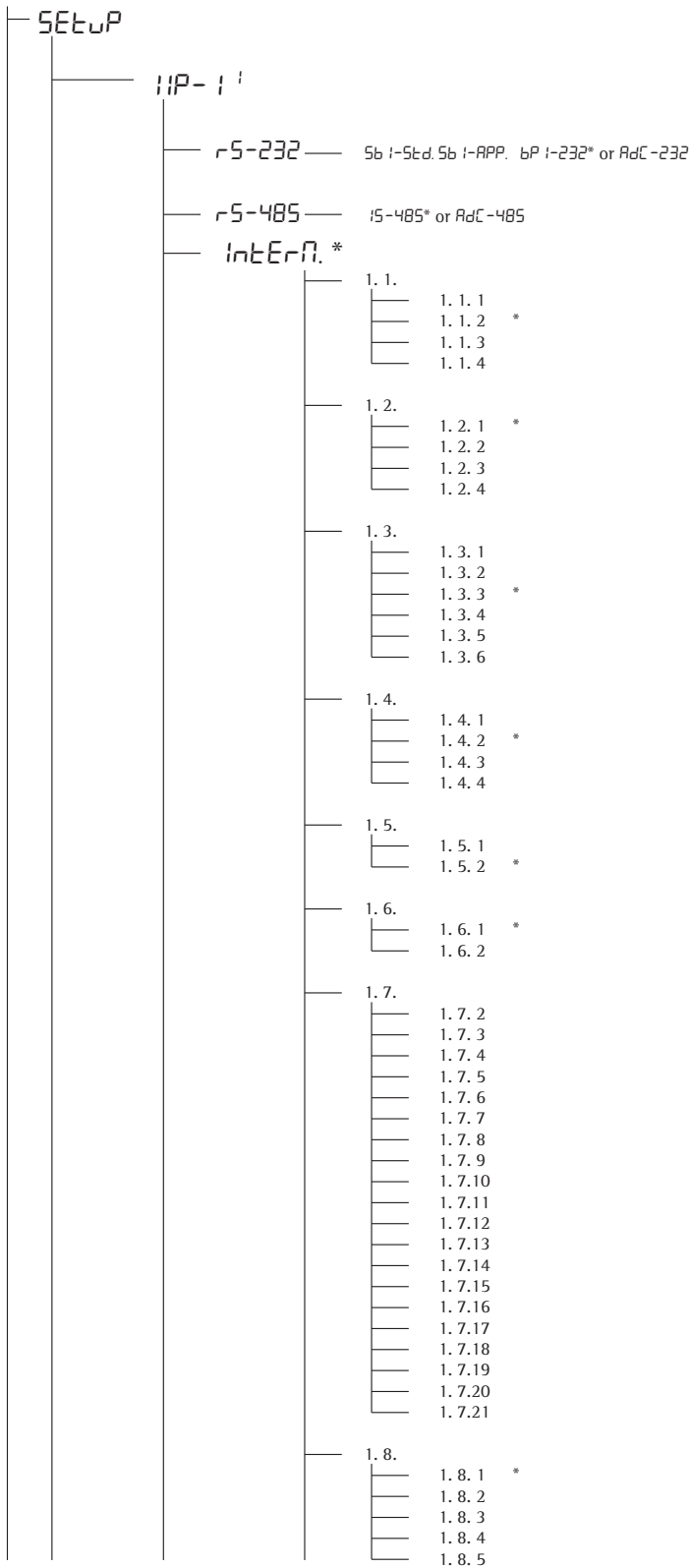

Device Parameters

Password prompt displayed, if a password is configured

Weighing Instrument 1

(Display designation of this menu level: :)

Menu parameters dependent on connected complete scale (e.g., EA/EB model, FB/FC model, etc.)

Optional: Menu parameters dependent on connected weighing platform

Built-in A/D Converter

Adapting Weighing Instrument to Ambient Conditions (Adapt Filter)

Very stable conditions
Stable conditions
Unstable conditions
Very unstable conditions

Application Filter

Final readout
Filling mode
Low filtering
Without filtering

Stability Range

1/4 digit
1/2 digit
1 digit ¹⁾
2 digits ¹⁾
4 digits ¹⁾
8 digits ¹⁾

Stability delay

No delay
Short delay
Average delay
Long delay

Taring ¹⁾

Without stability
After stability

Auto Zero

On
Off

Weight Unit ²⁾

Grams /g
Kilograms /kg
Carats /ct ¹⁾
Pounds /lb ¹⁾
Ounces /oz ¹⁾
Troy ounces /ozt ¹⁾
Hong Kong taels /tlh ¹⁾
Singapore taels /tls ¹⁾
Taiwanese taels /tlt ¹⁾
Grains /GN ¹⁾
Pennyweights /dwt ¹⁾
Milligrams /mg ¹⁾
Parts per pound /lb ¹⁾
Chinese taels /tlc ¹⁾
Mommies /mom ¹⁾
Austrian carats /k ¹⁾
Tola /tol ¹⁾
Baht /bat ¹⁾
Mesghal /MS ¹⁾
Tons /t

Display Accuracy 1

All digits
Reduced by 1 decimal place for load change
Resolution reduced by 1 scale interval (e.g., from 1 g to 2 g or from 5 g to 10 g)
Resolution reduced by 2 scale intervals (e.g., 1 g to 5 g)
Reduced by 1 decimal place ¹⁾

¹⁾ = Not available on instruments verified for use in legal metrology

²⁾ = Depends on weighing instrument model

SETUP		11P-1		IntErN.*	Built-in A/D Converter
				1.9.	Calibration, Adjustment
				1.9.1 *	Ext. calibration/adjustment; default weight
				1.9.3	Ext. calibration/adjustment; weight can be selected under menu item 1.18.1
				1.9.10	Press \rightarrow \rightarrow 2 sec: blocked
				1.10.	Calibration/adjustment sequence
				1.10.1	Calibration with automatic adjustment
				1.10.2 *	Calibration with adjustment triggered manually
				1.11.	Zero-setting Range
				1.11.1	1 percent/max. cap.
				1.11.2 *	2 percent/max.cap.
				1.12.	Initial Zero-setting Range
				1.12.2	2 percent/max. cap.
				1.12.3 *	5 percent/max.cap.
				1.13.	Tare/Zero at Power On
				1.13.1 *	On
				1.13.2	Off, load previous tare value
				1.13.3	Only zero at power on
				1.15.	Calibration Prompt
				1.15.1 *	Off
				1.15.2	Calibration prompt "ΔΔ" flashes in the display
				1.16.	External Calibration/Adjustment ¹⁾
				1.16.1 *	Accessible
				1.16.2 ²⁾	Blocked
				1.18.	Enter Calibration Weight
				1.18.1	External user-defined weight; enter value; e.g.: 10.000 kg)
				3.1.	Weight Unit ^{2 3)}
				3.1.2	Grams /g
				3.1.3	Kilograms /kg
				3.1.4	Carats /ct ¹⁾
				3.1.5	Pounds /lb ¹⁾
				3.1.6	Ounces /oz ¹⁾
				3.1.7	Troy ounces /ozt ¹⁾
				3.1.8	Hong Kong taels /tlh ¹⁾
				3.1.9	Singapore taels /tls ¹⁾
				3.1.10	Taiwanese taels /tlt ¹⁾
				3.1.11	Grains /GN ¹⁾
				3.1.12	Pennyweights /dwt ¹⁾
				3.1.13	Milligrams /mg ¹⁾
				3.1.14	Parts per pound /lb ¹⁾
				3.1.15	Chinese taels /tlc ¹⁾
				3.1.16	Mommies /mom ¹⁾
				3.1.17	Austrian carats /k ¹⁾
				3.1.18	Tola /tol ¹⁾
				3.1.19	Baht /bat ¹⁾
				3.1.20	Mesghal /MS ¹⁾
				3.1.21	Tons /t
				3.2.	Display Accuracy ²
				3.2.1 *	All digits
				3.2.2	Reduced by 1 decimal place for load change
				3.2.3	Resolution reduced by 1 scale interval (e.g., from 1 g to 2 g or from 5 g to 10 g)
				3.2.4	Resolution reduced by 2 scale intervals (e.g., 1 g to 5 g)
				3.2.5	Reduced by 1 decimal place ¹⁾
				9.1.	Restore Factory Settings for WP1 Numeric Menu
				9.1.1	Yes
				9.1.2 *	No
				OFF	A/D Converter Off

¹⁾ = Not available on instruments verified for use in legal metrology

²⁾ = Factory setting on instrument verified for use in legal metrology

³⁾ = Menu depends on weighing instrument model

Configuration

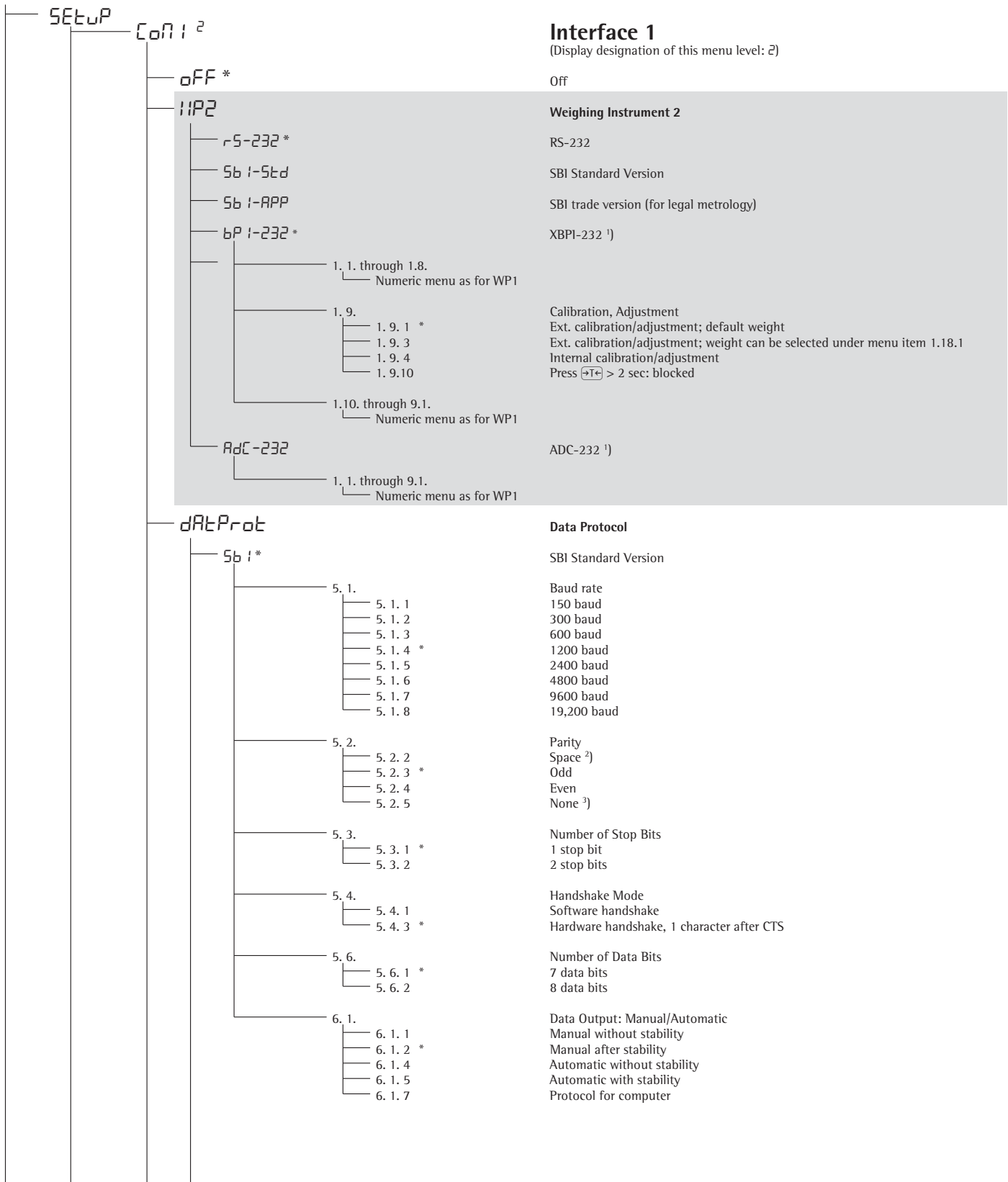

Interface 1

(Display designation of this menu level: 2)

Off

Weighing Instrument 2

RS-232

SBI Standard Version

SBI trade version (for legal metrology)

XBPI-232¹⁾

Calibration, Adjustment

Ext. calibration/adjustment; default weight

Ext. calibration/adjustment; weight can be selected under menu item 1.18.1

Internal calibration/adjustment

Press \rightarrow T \leftarrow > 2 sec: blocked

ADC-232¹⁾

Data Protocol

SBI Standard Version

Baud rate

150 baud
300 baud
600 baud
1200 baud
2400 baud
4800 baud
9600 baud
19,200 baud

Parity

Space²⁾
Odd
Even
None³⁾

Number of Stop Bits

1 stop bit
2 stop bits

Handshake Mode

Software handshake
Hardware handshake, 1 character after CTS

Number of Data Bits

7 data bits
8 data bits

Data Output: Manual/Automatic

Manual without stability
Manual after stability
Automatic without stability
Automatic with stability
Protocol for computer

¹⁾ = Menu depends on weighing instrument model

²⁾ = not with setting 5.6.2 (8 bits)

³⁾ = Not with setting 5.6.1 (7 bits)

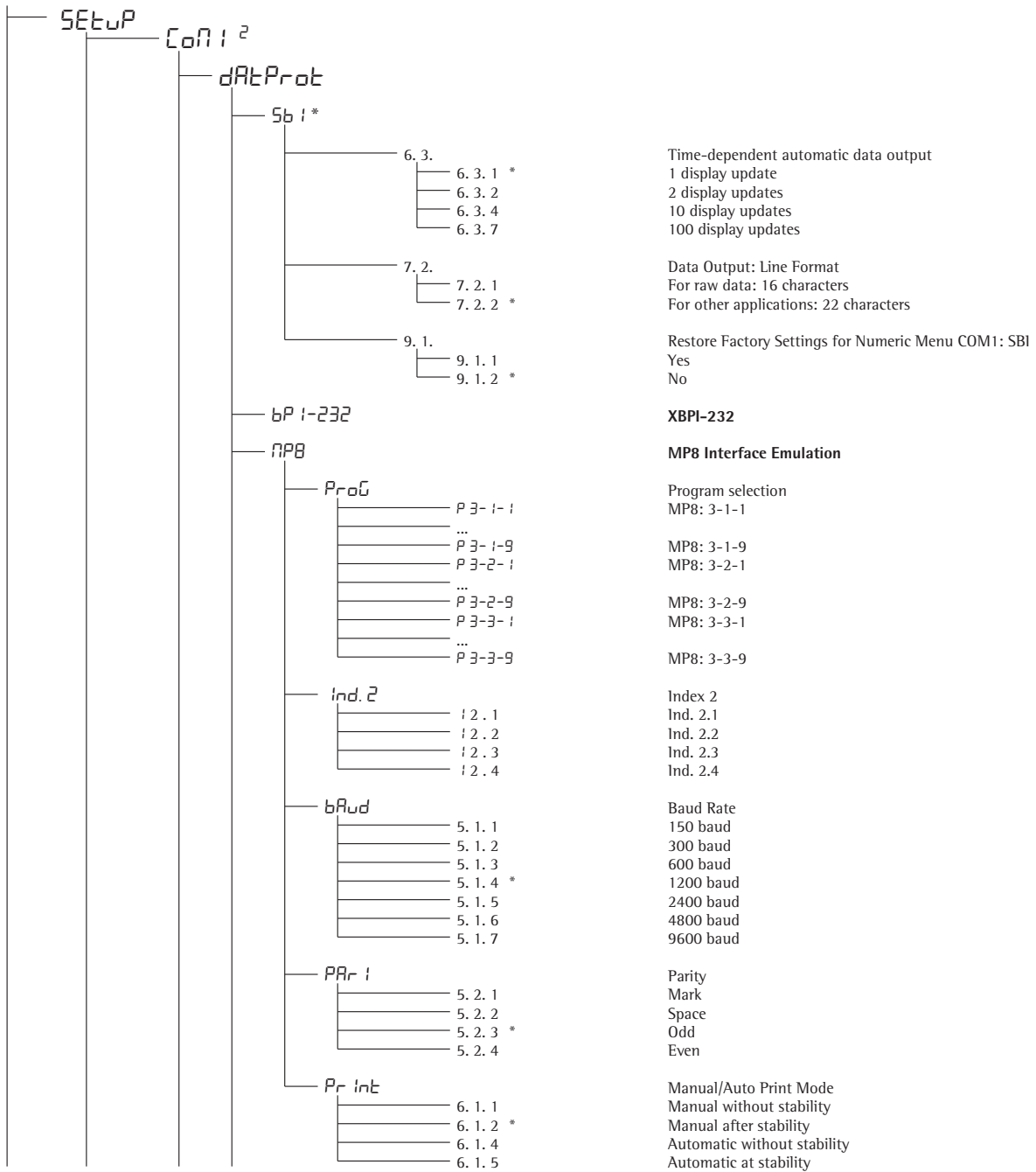

Configuration

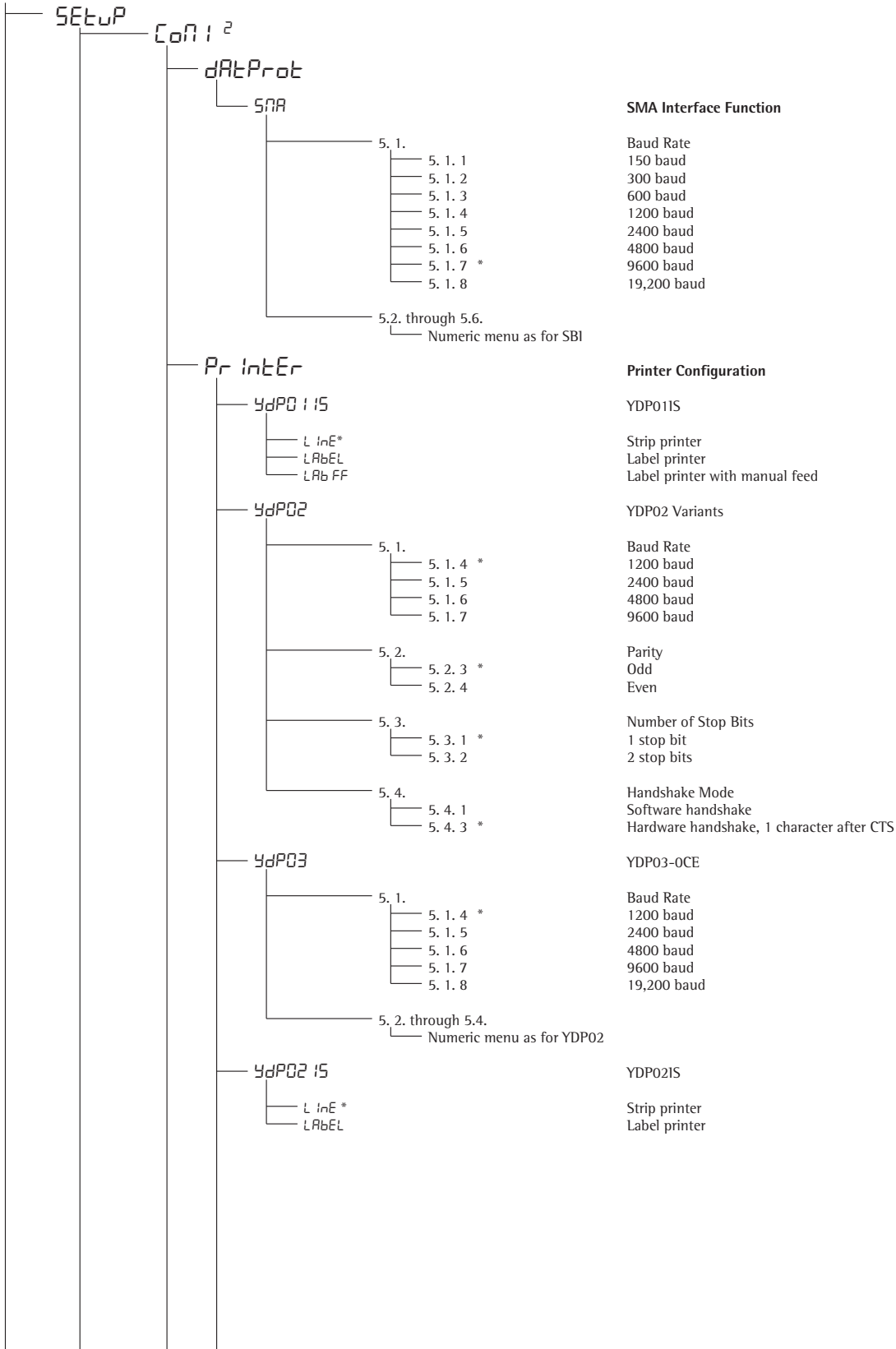

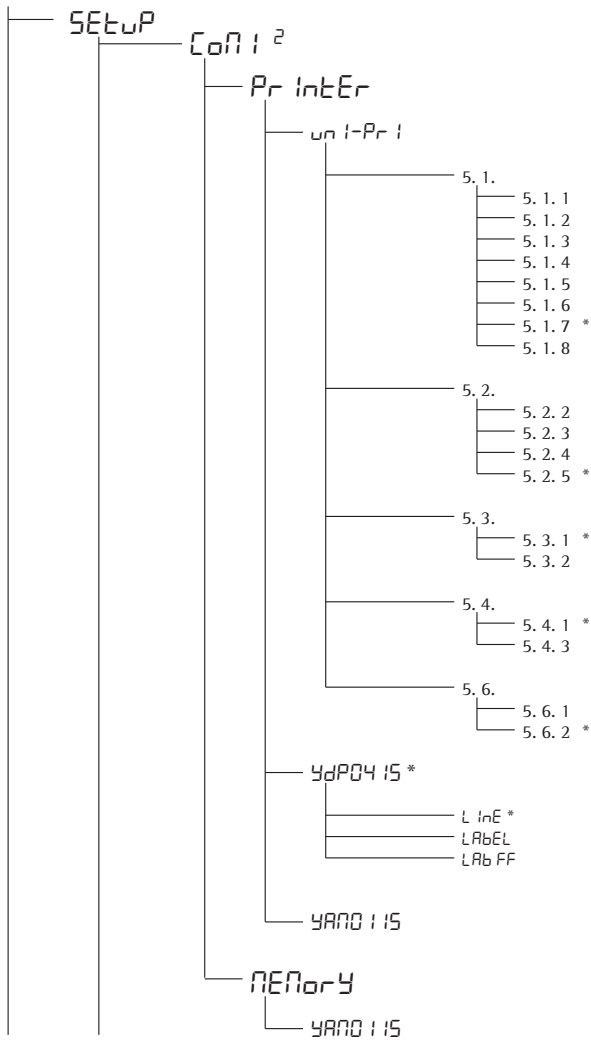

Universal Interface

Baud Rate
 150 baud
 300 baud
 600 baud
 1200 baud
 2400 baud
 4800 baud
 9600 baud
 19,200 baud

Parity
 Space ¹⁾
 Odd
 Even
 None ²⁾

Number of Stop Bits
 1 stop bit
 2 stop bits

Handshake Mode
 Software handshake
 Hardware handshake, 1 character after CTS

Number of Data Bits
 7 data bits
 8 data bits

YDP04IS

Strip printer
 Label printer
 Label printer with manual feed

YAM01IS as electronic memory for print data (external data logger)

Verifiable Data Memory

YAM01IS external data memory

¹⁾ = Not with setting 5.6.2 (8 bits)

²⁾ = Not with setting 5.6.1 (7 bits)

Configuration

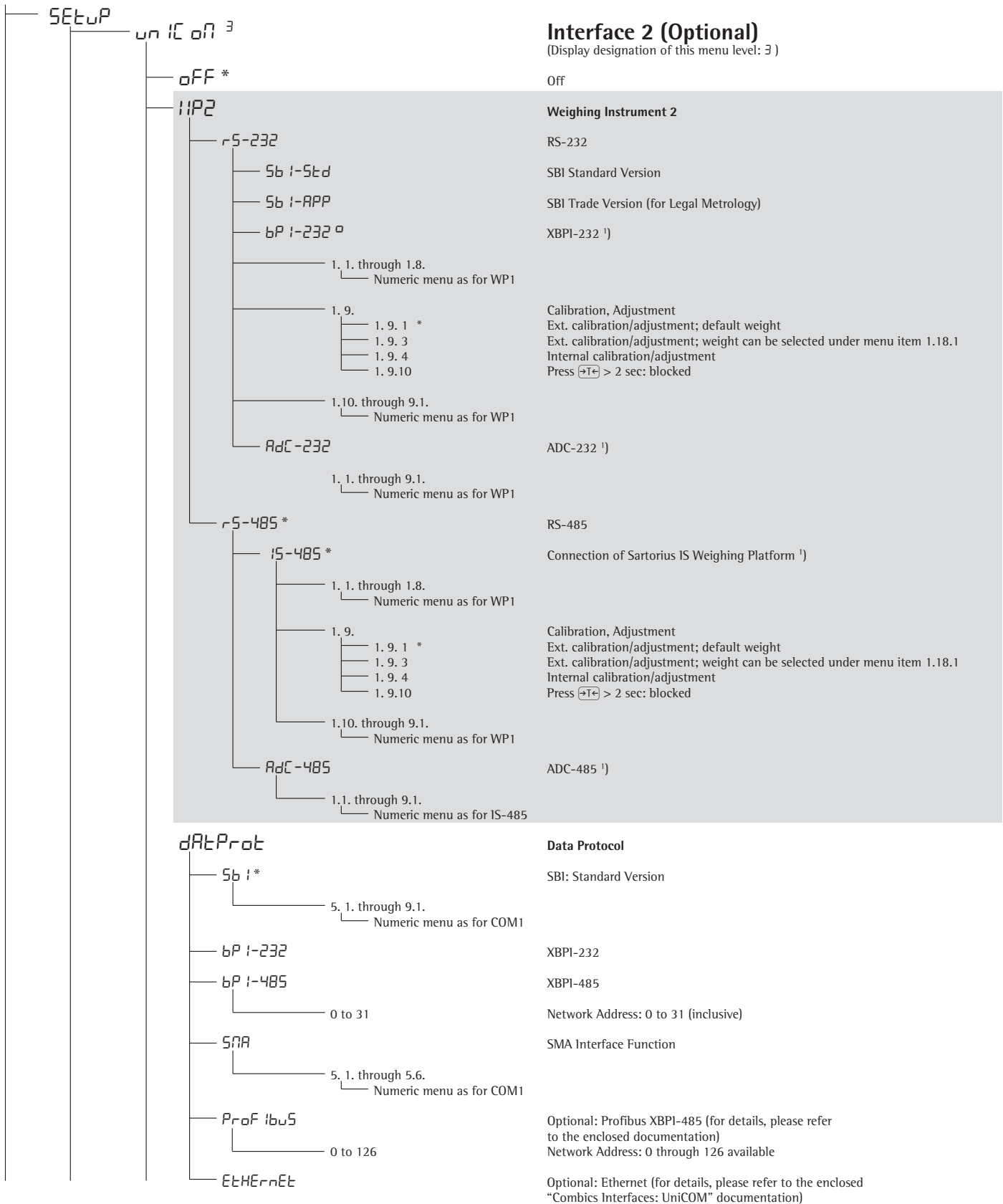

¹⁾ = Menu depends on connected weighing instrument

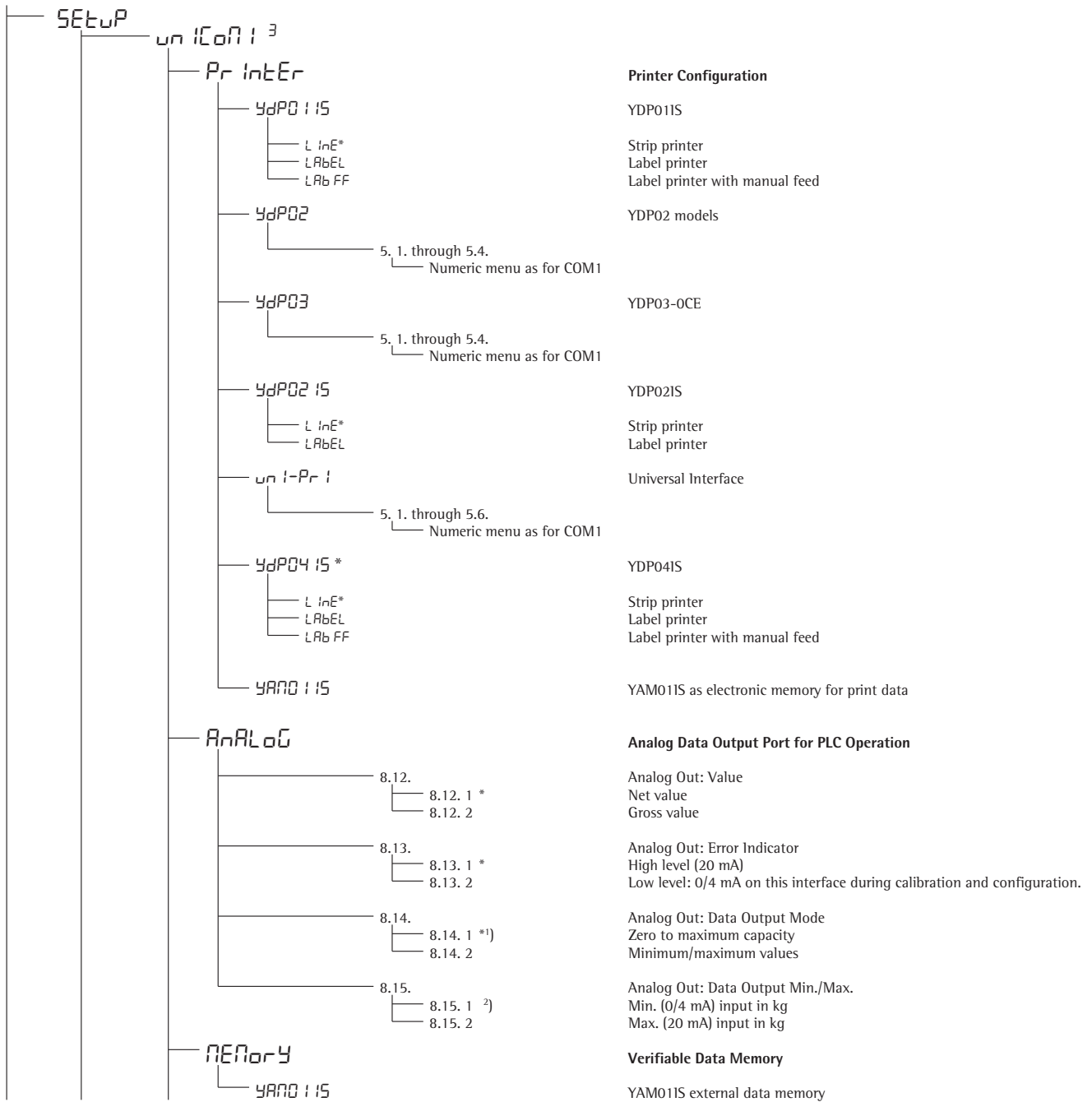

1) = When setting 8.14.1 is active, the analog data output only works for XBPI weighing instruments
 2) = Not with setting 8.14.1

Configuration

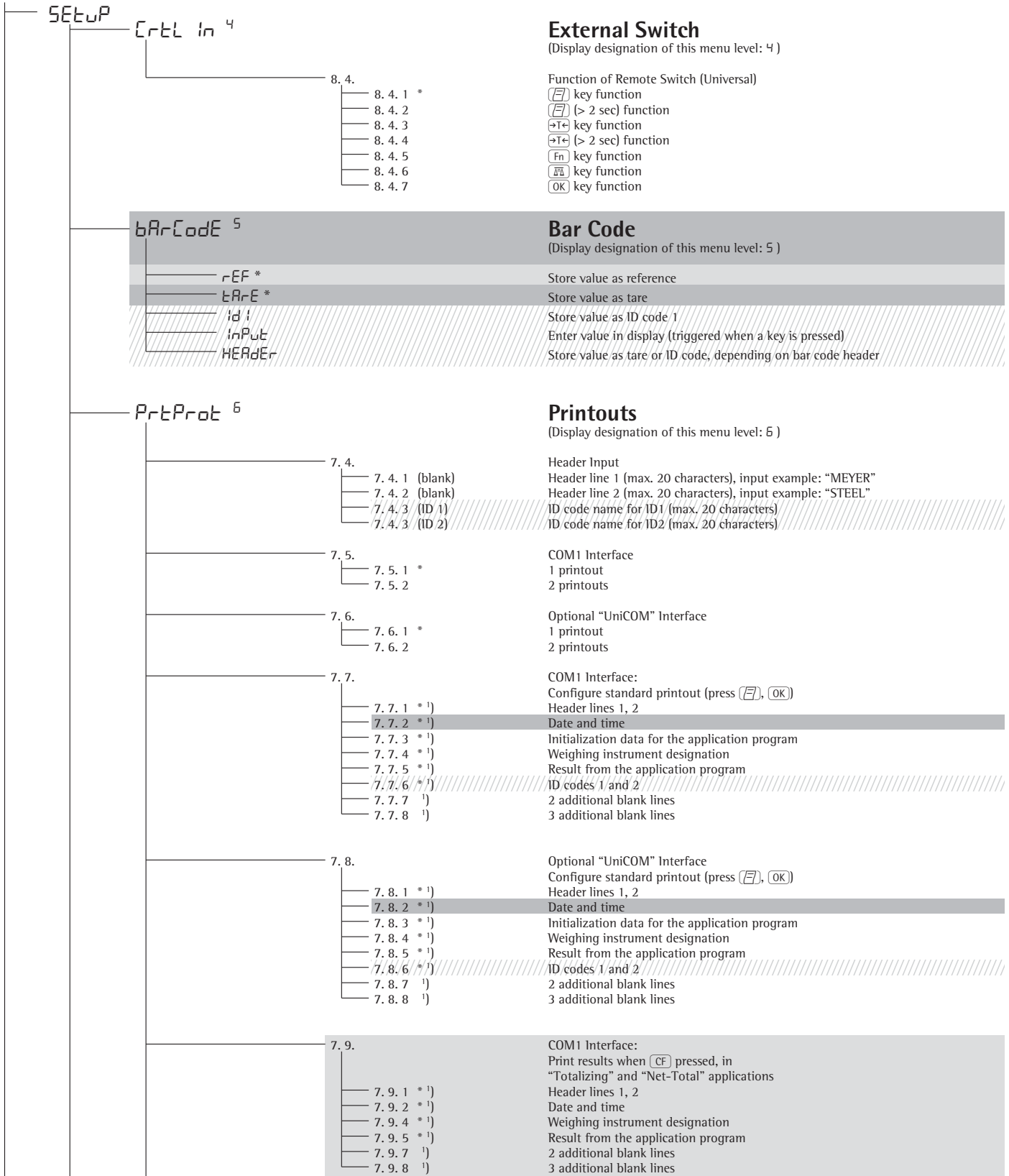

')} = More than one can be selected

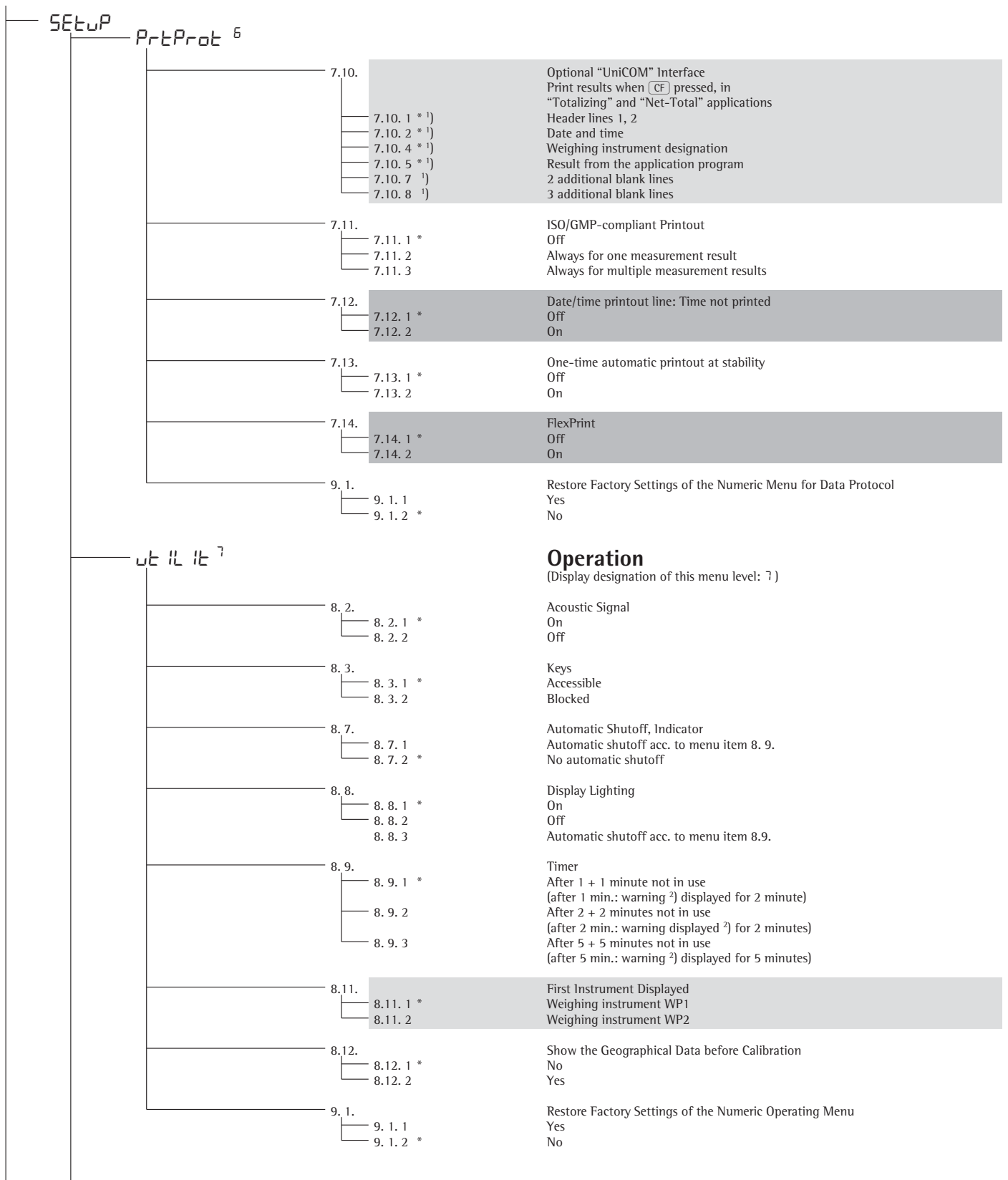

¹⁾ More than one can be selected

²⁾ Warning: "⚠" and 12 flash simultaneously

Configuration

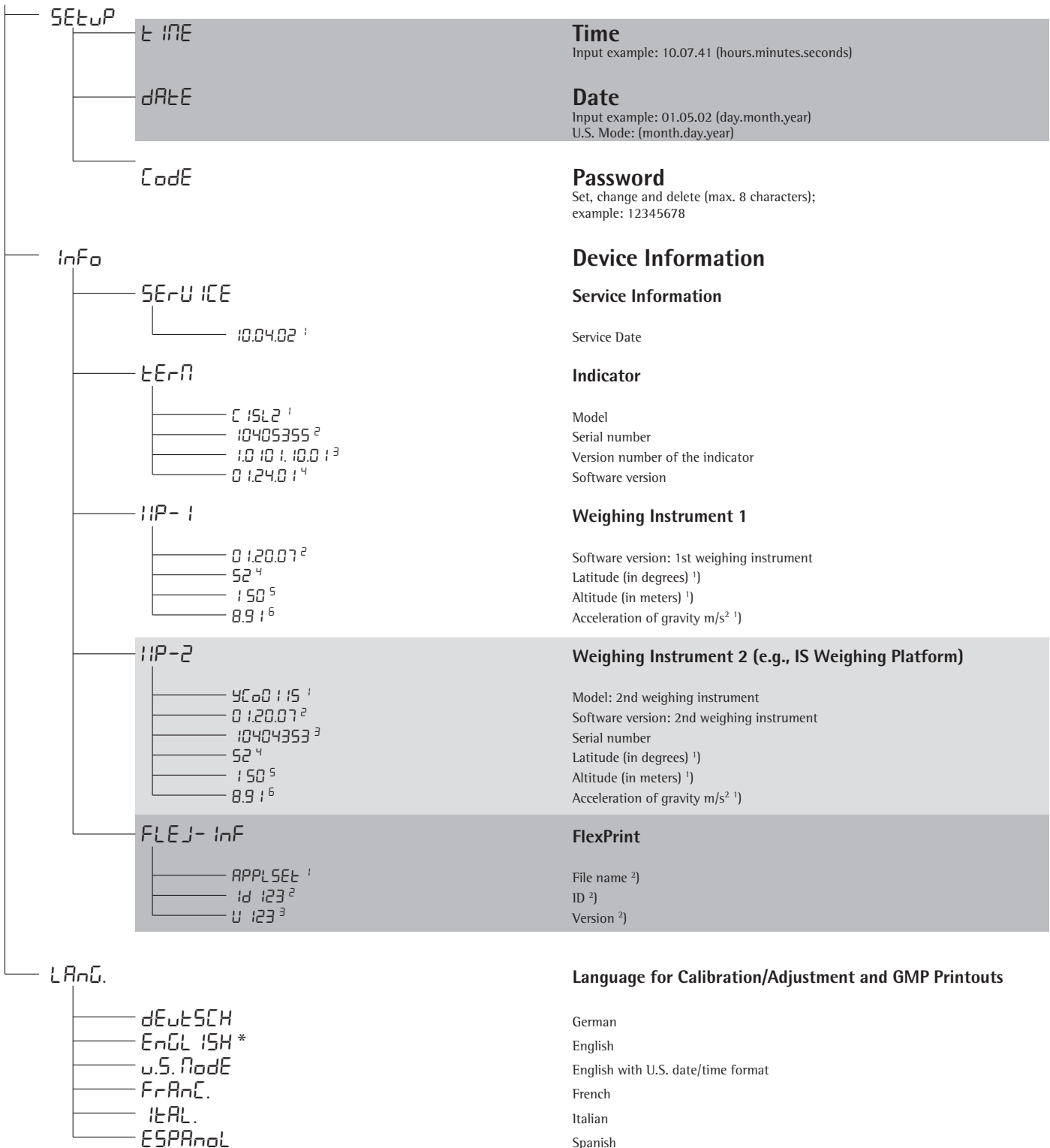

¹⁾ Output: either latitude and altitude or acceleration of gravity (depends on the input before verification)

²⁾ These three parameters are shown for each file loaded

Data Interfaces

The indicator is equipped with the following data interfaces:

- COM1: Standard interface (RS-232)
- UniCOM: Universal data interface (optional)

Both of these interfaces can be configured in the Setup menu for various input/output functions (e.g., Printer, second weighing instrument, PC, checkweighing/classification display). The optional UniCOM interface can be used for RS-232, RS-485 or RS-422 communication, or as voltage-/current (analog) interface. A bar code scanner (Combits 2 only) or an external rechargeable battery pack can be connected to the female UniCOM port (on CW1S, CW1NS and CW2S models, use the corresponding terminal screws).

Features

- Indicator models CW1P, CW1NP and CW2P (IP44 protection):
Connect via a 25-contact D-Sub female connector.
Use a T-connector (see "Accessories") to connect a second device to the same interface.
- Indicator models CW1S, CW1NS, CW1FS, CW1NFS, CW2FS, CH1NE, CH1NG and CW2S (IP67 protection):
Route connecting cable from the peripheral device to the indicator via a cable gland. Then connect the free ends of the cable using the terminal screws.
If you wish to connect a second peripheral device to the same interface port, use a separate cable gland to route the connecting cable of this device into the indicator.

⚠ Warning When Using RS-232 Connecting Cables Not Supplied by Sartorius:

The pin assignments in the cable might not be compatible with Sartorius equipment. Check all pin assignments against the cabling diagrams and disconnect any lines that are not assigned. Failure to do so may damage or even completely ruin your indicator and/or peripheral device.

Specifications

Serial interface:

Operating mode:	Full duplex	
Standard:	COM1:	RS-232,
	UniCOM ¹⁾ :	RS-232 or RS-422/RS-485
Interface connector:	CW1P, CW1NP and CW2P (IP44 protection): 25-contact D-Sub female connector CW1S, CW1NS and CW2S (IP67 protection): The cable is connected to terminal screws inside the housing and routed into the housing via a cable gland.	
Transmission rates:	150, 300, 600, 1200, 2400, 4800, 9600 and 19,200 baud (depending on the operating mode)	
Number of data bits:	7 or 8 bits	
Parity:	Space, odd, even, none (depending on the operating mode)	
Number of stop bits:	1 or 2 stop bits	
Handshake mode:	Software (XON/XOFF) or hardware (1 character after CTS)	
Communication mode:	SBI, XBPI-232 ²⁾ , XBPI-485 ¹⁾²⁾ , MP8 binary ³⁾ , SMA Available printers: <ul style="list-style-type: none"> - YDP01IS - YDP02IS-Label - YDP01IS-Label - Universal - YDP02 - YDP04IS - YDP03 - YDP04IS-Label - YDP02IS - YAM01IS Alibi memory 	
Network address ⁴⁾ :	0, 1, 2, (...), 31	
SBI: Manual data output:	Without stability, after stability, configurable printout	
SBI: Automatic data output:	Without stability, at stability, at user-defined intervals	
SBI: Output format:	16 or 22 characters	
Printout of application data:	Output of a configurable printout	

Analog UniCOM interface (optional)

Standard:	4 to 20 mA, 0 to 20 mA, 0 to 5V
Power supply:	Internal or external
Factory setting:	4 to 20 mA, internal power supply
Interface connector:	CW1P, CW1NP and CW2P indicators (IP44 protection): 25-contact D-Sub female connector CW1S, CW1NS and CW2S indicators (IP67 protection): The free ends of the cable are connected to terminal screws inside the housing; the cable is routed into the housing via a cable gland.

¹⁾ Optional UniCOM universal data interface

²⁾ XBPI operating mode: 9600 baud, 8 data bits, parity: odd, 1 stop bit

³⁾ Only with the standard COM1 interface

⁴⁾ Network address is valid only in the XBPI mode

Data Interfaces

Options for Connecting Peripherals

You can connect the following printers to the COM1 and UniCOM interfaces:

- YDP02 (user-definable interface parameters)
- YDP03 (user-definable interface parameters)
- YDP011S (strip or label printer)
- YDP021S (strip or label printer)
- YDP041S (strip or label printer)
- Universal printer (user-definable transmission parameters)
- YAM011S Alibi memory

The following devices can also be connected to the COM1 interface:

- Foot switch / hand switch
- PC (RS-232 interface)
- Second weighing instrument (Combics 2 only, RS-232 interface)
- External checkweighing display (red/yellow/green) over the digital I/O (Sartorius standard)

The connector of the UniCOM universal port enables the following devices to be connected:

- External rechargeable battery pack
- Bar code scanner (Combics 1 plus and Combics 2 only)

The following devices can also be connected to the UniCOM universal interface:

- PC (RS-232 interface)
- Second weighing instrument (Combics 2 only; can be switched from RS-232 to RS-485 operating mode)
- Second printer (external power source required)
- Remote display
- Current interface (0/4 - 20 mA)

⚠ If necessary, use an external power source to power peripheral devices.

Connecting a second weighing instrument:

Combics 2 enables connection of a second weighing instrument to either the COM1 or the UniCOM port.

COM1 operates in RS232 mode. A second weighing instrument on this port can use the following operating modes:

- SBI
- XBPI-232 (factory setting)
- ADC-232

UniCOM can operate in either the RS-232 mode or in RS-485 mode. A second weighing instrument on this port can use the following operating modes:

- SBI (RS-232 mode)
- XBPI-232 (RS-232 mode)
- ADC-232 (RS-232 mode)
- IS-485 (RS-485 mode, XBPI mode; factory setting)
- ADC-485 (RS-485 mode)

Connecting a Printer

The standard COM1 port or the optional universal UniCOM interface (or both) can be used as a printer interface.

Operation as a COM Port

For operation as a COM port, you can adapt the data protocol to the following operating modes:

- SBI (factory setting)
- XBPI-232
- XBPI-485 (only UniCOM)
- MP8-binary (only COM1)
- SMA

You can operate the COM1 port and the UniCOM port independently of one another (i.e., for transferring data and controlling equipment via a PC while simultaneously outputting data to the COM1 printer port).

In the SBI communication mode, you can control a display unit and a connected weighing instrument by sending ESC commands from a PC to the communications port (COM1 or UniCOM) (see page 96).

⚠ When using two interfaces (COM1 and UniCOM) each device can be configured only once. Devices are as follows:

- WP1-2
 - Data communication
 - External Alibi memory
 - Analog output port
- If you attempt to configure a device a second time (e.g., for the UniCOM port) after it has been configured another port (e.g., "Data communication" on COM1), error code INF 74 is displayed.

Pin Assignment Charts

Models CW1P, CW1NP, CW2P (IP44-protected):

Female Connectors COM1 and UniCOM:

25-contact D-Submini DB25S with screw lock hardware

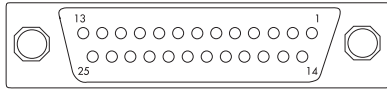

Front view

Male interface connector used (please use connectors with the same specifications):
25-pin D-Submini DB25, with integrated shielded cable clamp assembly (Amp type 826 985-1C) and fastening screws (Amp type 164868-1)

Pin assignments, COM1:

Pin 1:	Shield
Pin 2:	Data output (TxD)
Pin 3:	Data input (RxD)
Pin 4:	Not connected
Pin 5:	Clear to send (CTS)
Pin 6:	Internally connected
Pin 7:	Internal ground (GND)
Pin 8:	Internal ground (GND)
Pin 9:	Not connected
Pin 10:	Not connected
Pin 11:	+12 V for printer
Pin 12:	RES_OUT\
Pin 13:	+5V
Pin 14:	Internal ground (GND)
Pin 15:	Universal remote switch
Pin 16:	Control output "lighter"
Pin 17:	Control output "equal"
Pin 18:	Control output "heavier"
Pin 19:	Control output "set"
Pin 20:	Data terminal ready (DTR)
Pin 21:	Supply ground (GND)
Pin 22:	Not connected
Pin 23:	Not connected
Pin 24:	Power supply +15...25 V
Pin 25:	+5V

Pin Assignment Chart: 2nd Interface: Connection of external rechargeable battery and bar code scanner¹⁾ (optional UniCOM interface not installed)

Pin 1:	Shield
Pin 2:	Not connected / *
Pin 3:	Not connected / *
Pin 4:	Internal ground (GND)
Pin 5:	Not connected / *
Pin 6:	Not connected / *
Pin 7:	Not connected / *
Pin 8:	Not connected / *
Pin 9:	Not connected / *
Pin 10:	Not connected / *
Pin 11:	+12 V for printer
Pin 12:	RES_OUT\
Pin 13:	+5 V switch
Pin 14:	Internal ground (GND)
Pin 15:	Keyboard data
Pin 16:	Not connected / *
Pin 17:	Not connected / *
Pin 18:	Not connected / *
Pin 19:	Keyboard clock
Pin 20:	Not connected / *
Pin 21:	LINE_1 _GND
Pin 22:	LOW_BATT ²⁾
Pin 23:	BATT_ON_OFF ³⁾
Pin 24:	LINE_1_B
Pin 25:	+5V

- * Pin assignments depending on the UniCOM used
 1) Combits 2 only
 2) Signal from battery pack: battery drained
 3) Switch off battery pack when weighing instrument switched off

Data Interfaces

Models CW1S, CW1NS, CW1FS, CW1NFS, CW2FS, CH1NE, CH1NG and CW2S (IP 67-protected):

Connection of open cable ends to terminal screws inside the indicator

COM1 interface connections:

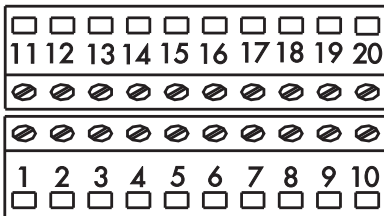

Top view

Terminal assignments

- No. 1: Universal switch
- No. 2: Control output "set"
- No. 3: Control output "heavier"
- No. 4: Control output "equal"
- No. 5: Control output "lighter"
- No. 6: Clear to send (CTS)
- No. 7: Data output (TxD)
- No. 8: Data input (RxD)
- No. 9: Data terminal ready (DTR)
- No. 10: Internal ground (GND)
- No. 11: LINE_A
- No. 12: LINE_A
- No. 13: GND_LINE_A
- No. 14: GND_LINE_A
- No. 15: +12 V for printer
- No. 16: Reset output
- No. 17: +5 V
- No. 18: +5 V
- No. 19: Ground (GND)
- No. 20: Ground (GND)

Models CIS1, CIS1N and CIS2:
Terminals on the PCB

Connection of weighing instrument (page 72)

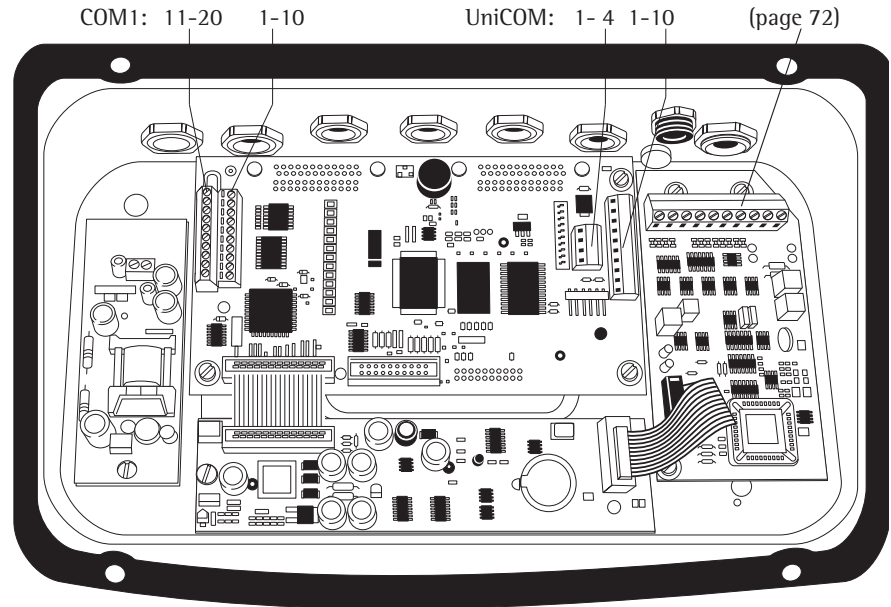

Second connection: For connecting an external battery pack and a bar code scanner ¹⁾ (optional UNICOM interface not installed)

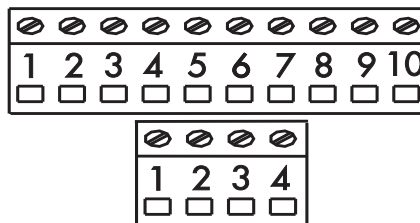

Terminal assignments in the 10-terminal strip

- No. 1: Not connected*
- No. 2: GND
- No. 3: GND
- No. 4: +5V Switch
- No. 5: Not connected *
- No. 6: Keyboard clock
- No. 7: Keyboard data
- No. 8: Not connected *
- No. 9: Not connected *
- No. 10: Not connected *

Terminal assignments in the 4-terminal strip

- No. 1: Supply, ground (GND_LINE_B)
- No. 2: Supply, battery pack
- No. 3: LOW_BATT ²⁾
- No. 4: BATT_ON_OFF ³⁾

* Pin assignments depending on the UniCOM used
¹⁾ Combics 2 only
²⁾ Signal from battery pack: battery drained
³⁾ Switch off battery pack when weighing instrument switched off

Installing the Interface Cable

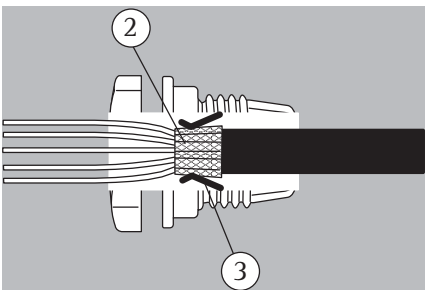
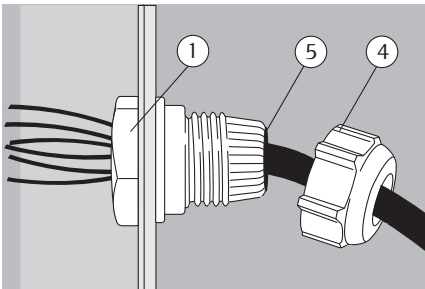
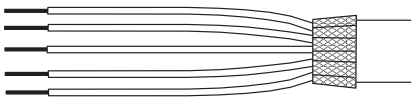
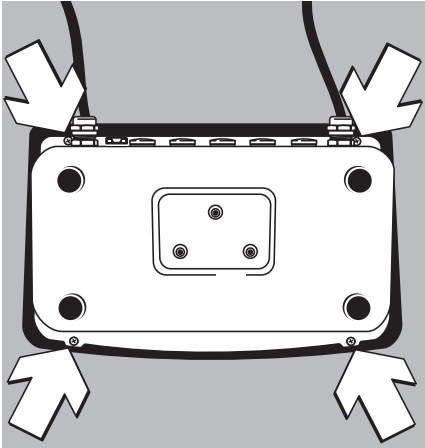

- ⚠ Peripheral devices should be connected to the interfaces only by a trained and authorized Sartorius technician. Any installation work that does not conform to the instructions in this manual will result in forfeiture of all claims under the manufacturer's warranty.
- ⚠ Disconnect the equipment from power (unplug from the wall socket) before beginning any installation work.
- Open the Combics indicator:
 - remove the four cap nuts from the front panel and remove the panel.

● Prepare the cable:

- Expose approx. 10 cm (4 in) of the cable end for installation
- Remove all but approx. 1 cm (1/2 in) of the shielding and fold it back over the casing
- Strip the casing from approximately 1 cm (1/2 in) of the wires and attach ferrules to the wire ends.

● Attach the cable gland:

- ⚠ Please use extreme caution when performing any work on the equipment that affects this cable gland. Use a torque wrench and tighten the cable gland to 5 Nm.
- Remove the protective cap from the bore hole on the indicator.
- Guide the enclosed cable gland through the bore hole and secure it inside the housing with the nut (1).

- Slide the cable gland over the cable until the clamps (3) are in contact with the shield (2). Tighten the nut (4) until the sealing clamp (5) forms a slight ridge between nut and cable.
- Make sure the shield is in contact with the clamps.

- Connect the wires securely in accordance with the terminal assignments.

- After you close the housing again, use a pressure gauge to check the integrity of the IP67-protection. For details, contact the Sartorius Service Center.

Data Interfaces

Cabling Diagram (Adapter Cable for PC)

(Model CW1P | CW1NP | CW2P: adapter cable 7357312; model CW1S | CW1NS | CW2S: connecting cable YCC02-D9F6).
 Diagram for connecting a computer or other peripheral device to the indicator using the RS-232-C/V24 standard and cables up to 15 m (50 ft.) long:

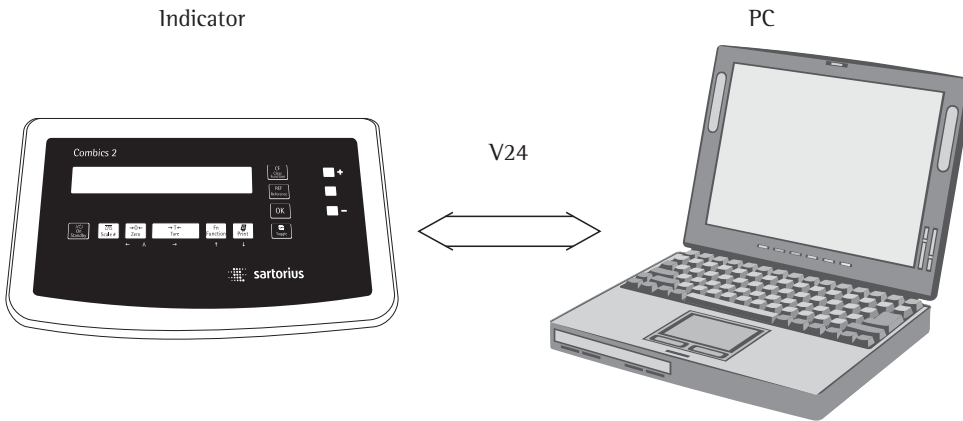

Cabling diagram

Connection assignments for the cable from the indicator to an RS-232 PC interface

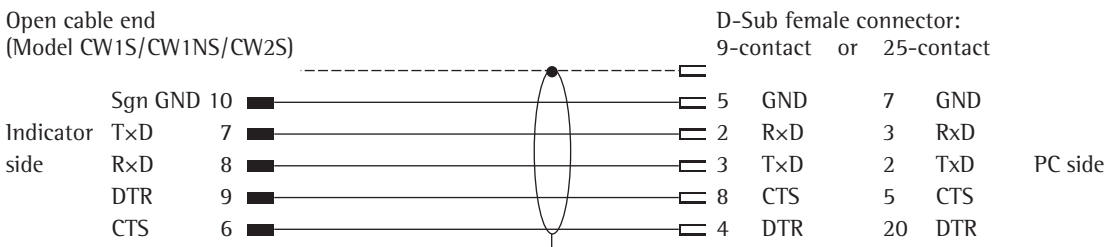
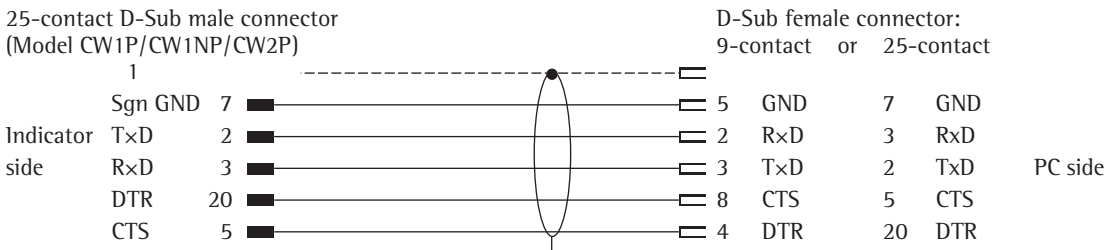

Synchronization

Data communication between the indicator and a computer takes the form of messages (“telegrams”) made up of ASCII code. For error-free data communication, the settings for baud rate, parity, handshake mode and character format must be the same at both ends.

You can configure the interface settings in the Setup menu so that they match those of the computer. You can also define parameters in the indicator to make data output dependent on various conditions. The conditions that can be configured are listed in the descriptions of the application programs.

If you do not connect a peripheral device to the indicator’s interface port, this will not generate an error message.

Handshake

The weighing instrument interface (Sartorius Balance Interface = SBI) has transmit and receive buffers. You can define the handshake parameter in the indicator’s Setup menu:

- Hardware handshake (CTS/DTR)
- Software handshake (XON, XOFF)

Hardware Handshake

Hardware handshake with a 4-wire interface: 1 more character can be transmitted after CTS (clear-to-send).

Software Handshake

The software handshake is controlled via XON and XOFF. When a device switched on, XON must be transmitted to enable a connected device to communicate.

When the software handshake is configured in the Setup menu, the hardware handshake becomes active after the software handshake.

The data transmission sequence is as follows:

```
Scale      --- byte ---> Computer
(trans-    --- byte ---> (receiving
mitting    --- byte ---> device)
device)    --- byte --->
          <-- XOFF ---
          --- byte --->
          --- byte --->
          ...
          (Pause)
          ...
          <-- XON ---
          --- byte --->
          --- byte --->
          --- byte --->
          --- byte --->
```

Transmitting Device

Once XOFF has been received, it prevents further transmission of characters. When XON is received, it re-enables the transmitting device to send data.

Receiving Device

To prevent too many control commands from being received at one time, XON is not transmitted until the buffer is almost empty.

Data Interfaces

Configuring the Data Interface as a COM Port (DataPort)

Configure the interface as a COM port in the Setup menu as a COM1 or UniCOM port under the “Data Protocol” (DataPort) menu item.

SBI Communication

This is a simple ASCII interface. Data output is configured under menu items 6.1 and 6.3:

- Manual output of displayed value with or without stability (menu items 6.1.1 and 6.1.2)
- Automatic output of displayed value with or without stability (menu items 6.1.4 and 6.1.5) at intervals defined in display updates. The number of display updates comprising an output interval is configured under menu item 6.3.
- Output of a printout as configured in the Setup program (menu item 6.1.7). Output is linked to the “Data Protocol” menu item (DataPort) (see page 100, “Configuring Printouts”).

If you do not activate and configure a user-definable data record, the printout simply contains the current value displayed on the indicator (weight with unit, calculated value, alphanumeric display).

SMA Communication

Standardized communications protocol of the Scale Manufacturers Association

MP8 Binary

Purpose

With the MP8 interface you can connect MP8-generation peripheral devices with separate power supplies to the Combics indicator.

Features

- The weighing instrument is used only for determining weight values.
- The data interface transmits only in MP8 binary protocol
- The application program for MP8 can be selected under menu item 3
- The program index 2 for MP8 can be selected under menu item 4.
- “MP8 interface emulation” is not permitted in legal metrology.

Data Input Format

You can connect a computer to your indicator to send commands controlling weighing instrument functions and applications via the interface port. All commands use the same format (data input format) starting with the ESC character (ASCII 27) and ending with a carriage return (CR; ASCII 13) and a line feed (LF; ASCII 10). The total length of a command is anywhere from 4 characters (1 command character between the start and end described above) to 7 characters (4 command characters).

The table below shows the available command characters; each command must be flanked by the start and end characters as described above.

Example: The command character for output is “P” (“output to Port”). The string “ESC P CR LF” triggers this command.

Command	Meaning
K	Weighing mode 1
L	Weighing mode 2
M	Weighing mode 3
N	Weighing mode 4
O	Block all keys
P	Output readout to data interface
Q	Output acoustic signal
R	Release (unblock) keys
T	Tare and zero (combination tare function)
f3_	Zero (see also the “kZE_” command)
f4_	Tare without zeroing (see also the “kT_” command)
i_	Information about the indicator Example of output: “C12/012502/1” Meaning: Indicator: Combics 2, software version: 012502, active weighing instrument: 1
kF1_	F1: Trigger (Fn) key function
kF2_	F2: (CF) key function (Combics 2 only)
kF3_	F3: (REF) key function (Combics 2 only)
kF4_	F4: (OK) key function (Combics 2 only)
kF5_	F5: (S) key function (Combics 2 only)

Command	Meaning
kF6_	F6: Trigger (Info) key function (Combics 1 plus only)
kF7_	F7: (ID1) key function (Combics 1 plus only)
kF8_	F8: (ID2) key function (Combics 1 plus only)
kCF_	CF: (CF) key function (Combics 2 only)
kP_	(E) key function Output to printer port
kT_	(T) key function (tare)
kNW_	(A) key function (Toggle the weighing instrument)
kZE_	(+0) key function (zero the instrument)
x1_	Output model designation of active weighing instrument. Example: “LP6200S-0C”
x2_	Output serial number of active weighing instrument; example: “0012345678 ”
x3_	Output software version of active weighing instrument; example: “ 00-20-04 ”
x4_	Output software version of indicator; example: “ 01-25-02 ”
x9_	Output serial number of indicator; example: “0012345678 ”
x10_	Output model of indicator; example: “CW2P4-1500RR-LCE”
z1_	Activate input for printout header 1
z2_	Activate input for printout header 2
txx...x_	xx...x: Input text Length acc. to input (Combics 1 plus only)

The ASCII code for the “underline” character is 95.

Format for entering printout header lines: ESC z x a ... a _ CR LF where x=(header line) 1 or 2; a ... a: a...a= up to 20 characters of text, followed by the “underline” character, carriage return and line feed.

Data Output Format

You can output the values displayed in the line for measured values and the weight unit with or without a data ID code. The first 6 characters, called the data header, show the data ID code identifying the subsequent value. Select menu item 7.2 to define whether the data ID code is included in output or not.

Examples:
 + 235 pcs Without data ID code
 Qnt + 235 pcs With data ID code

Display segments that are not activated are output as spaces. Values with no decimal point are output without a decimal point.

Data Output Format with 16 Characters (without Data Header)

Normal Operation

Position	1	2	3	4	5	6	7	8	9	10	11	12	13	14	15	16
		+	*	D	D	D	D	D	D	D	*	U	U	U	CRLF	
or		-	*	D	D	D	D	D	D	D	*	U	U	U	CRLF	
or	*	*	*	*	*	*	*	*	*	*	*	*	*	*	*	CRLF

+ -: Plus or minus sign
 *: Space
 D: Digit or letter (max. 7 characters plus decimal point)
 U: Unit symbol (1 - 3 letters, followed by 0 - 2 spaces)
 CR: Carriage return
 LF: Line feed

Special Codes

Position	1	2	3	4	5	6	7	8	9	10	11	12	13	14	15	16
	*	*	*	*	*	*	-	-	*	*	*	*	*	*	*	CRLF
or	*	*	*	*	*	*	H	*	*	*	*	*	*	*	*	CRLF
or	*	*	*	*	*	*	H	H	*	*	*	*	*	*	*	CRLF
or	*	*	*	*	*	*	L	*	*	*	*	*	*	*	*	CRLF
or	*	*	*	*	*	*	L	L	*	*	*	*	*	*	*	CRLF
or	*	*	*	*	*	*	C	*	*	*	*	*	*	*	*	CRLF

*: Space
 --: Final readout mode
 H: Overload
 HH: Overload in Checkweighing
 L: Underload
 LL: Underload in Checkweighing
 C: Calibration/adjustment

Error Codes

Position	1	2	3	4	5	6	7	8	9	10	11	12	13	14	15	16
	*	*	*	E	r	r	*	*	#	#	*	*	*	*	*	CRLF
or	*	*	*	E	r	r	*	#	#	#	*	*	*	*	*	CRLF

*: Space
 #: Error code number (2 or 3 digits)

Example (output of value: +1255.7 g):

Position	1	2	3	4	5	6	7	8	9	10	11	12	13	14	15	16
		+	*	*	*	1	2	5	5	.	7	*	g	*	*	CRLF

Position 1: Plus or minus sign or space
 Position 2: Space
 Positions 3-10: Weight value with decimal point; leading zeros are output as spaces.
 Position 11: Space
 Positions 12-14: Unit symbol or space
 Position 15: Carriage return
 Position 16: Line feed

Data Output Format with 22 Characters

Normal Operation

Position	1	2	3	4	5	6	7	8	9	10	11	12	13	14	15	16	17	18	19	20	21	22
		1	1	1	1	1	1	+	*	D	D	D	D	D	D	D	*	U	U	U	CRLF	
or		1	1	1	1	1	1	-	*	D	D	D	D	D	D	D	*	U	U	U	CRLF	
or	*	*	*	*	*	*	*	*	*	*	*	*	*	*	*	*	*	*	*	*	*	CRLF

11: ID code character, right-justified with spaces
 + -: Plus or minus sign
 *: Space
 D: Digit or letter (max. 7 characters plus decimal point)
 U: Unit symbol (1 - 3 letters, followed by 0 - 2 spaces)
 CR: Carriage return
 LF: Line feed

Special Codes

Position	1	2	3	4	5	6	7	8	9	10	11	12	13	14	15	16	17	18	19	20	21	22
		S	t	a	t	*	*	*	*	*	*	*	*	*	-	-	*	*	*	*	*	CRLF
or		S	t	a	t	*	*	*	*	*	*	*	*	*	H	*	*	*	*	*	*	CRLF
or		S	t	a	t	*	*	*	*	*	*	*	*	*	H	H	*	*	*	*	*	CRLF
or		S	t	a	t	*	*	*	*	*	*	*	*	*	L	*	*	*	*	*	*	CRLF
or		S	t	a	t	*	*	*	*	*	*	*	*	*	L	L	*	*	*	*	*	CRLF
or		S	t	a	t	*	*	*	*	*	*	*	*	*	C	*	*	*	*	*	*	CRLF

** : Space
 H: Overload
 L: Underload
 C: Calibration/adjustment
 --: Final readout mode
 HH: Overload in Checkweighing
 LL: Underload in Checkweighing

Data Interfaces

Error Codes

```

Position 1 2 3 4 5 6 7 8 9 10 11 12 13 14 15 16 17 18 19 20 21 22
          S t a t * * * * * E r r * * # # * * * * * CRLF
or       S t a t * * * * * E r r * # # # * * * * * CRLF
  
```

*: Space
#: Error code number (2 or 3 digits)

ID Code Characters

ID character	Meaning
G#	Gross value
N	Net value
T	Application tare memory 1
T2	Application tare memory 2
D i f f	Difference from calibration value
N o m .	Exact calibration weight
N o m .	Exact calibration weight using SBI output
n R e f	Reference sample quantity
p R e f	Reference percentage
w R e f	Reference sample weight
Q n t	Result from Counting application Result from Counting (piece count) and Neutral Measurement applications
m D e f	Target value for Animal weighing
x - N e t	Result from Animal Weighing
S e t p	Target value for Checkweighing
W . D i f f	Absolute difference (e.g., in kg) in Checkweighing
L i m	Deviation in % in Checkweighing
M a x	Upper limit for Checkweighing
M i n	Lower limit for Checkweighing
S t a t	Status
C l a s s x	Classification
L i m x	Class limit
D	Percentage (as loss)
P r c	Percentage (as residue)
W x x %	Reference percentage weight
C o m p x x x	Component xxx
C o n t . T	Contents of the tare memory in Net-total Formulation
T o t . c p	Total weight in Net-Total Formulation
P T 2	Preset tare
n	Transaction counter
* G	Sum of gross weights in Totalizing
* N	Sum of net weights in Totalizing
S e r . n o	Serial number of the weighing instrument or indicator

Example (output of value: +1255.7 g):

```

Position 1 2 3 4 5 6 7 8 9 10 11 12 13 14 15 16 17 18 19 20 21 22
          G # * * * * * + * * * * 1 2 5 5 . 7 * g * * CRLF
  
```

Positions 1-6: ID code character, right-justified with spaces
 Position 7: Plus or minus sign or space
 Position 8: Space
 Positions 9-16: Weight value with decimal point;
 leading zeros are output as spaces.
 Position 17: Space
 Positions 18-20: Unit symbol or space
 Position 21: Carriage return
 Position 22: Line feed

△ If the weight value is output with 10-fold increased resolution, this value is not permitted to be printed or saved in a weighing instrument operated in legal metrology in the SBI mode. In this case, the unit symbol is not included with output.

Configuring the Data Interface as a Printer Port (PrInTEr)

You can connect one or two strip printers or one or two label printers to the Combics. Configure the COM1 and UniCOM interfaces as printer ports under the "PrInTEr" menu item.

There are several actions that generate the command for outputting data to the printer port:

- Pressing the E key. If the operating menu is active, all menu settings under the active menu level are printed.
- On receipt of the SBI command "Esc k P _". For details, see "Data Input Format" in this chapter.
- In some applications, pressing a given key (e.g., to save a value or start a routine) also generates a print command. In this case, a configurable printout is generated with application-specific data.

The C D symbols are displayed when data is being output to the printer port.

Configuring Printouts

Configure printouts in the Setup menu is under the "Printouts" menu item (PrTEPrTE). The printout should be formatted only after the desired application has been configured, as some of the positions are application-dependent. You can configure a different printout for each interface. Each printout contains your choice of the information blocks described in the following; to enable or disable a block in the printout, select it or deselect it in the Setup menu. Combics 2 only: For the "Totalizing" and "Net-Total" applications, you can also configure summarized printouts (results) independent of individual component value printouts.

Block 1: Headers

You can define 2 headers, each with 20 characters per line (e.g., for printing your company's name). Enter the header lines under menu items 7.4.1 and 7.4.2. Blank header lines are not printed.
Example: format of Block 1:

```
ACE HARDWARE
GOETTINGEN
```

In this example, the company name is centered on the printout. This was achieved by entering blank spaces at the beginning of each line.

Block 2: Date/Time

(not on Combics 1)
Example: format of Block 2:

```
21.01.2001 16:02
```

To obtain a standardized time stamp (e.g., for documentation within a completely automated system), you can suppress the printout of the time stamp in the "Date / time" information block. This function is controlled under menu code 7 -12, "Time not printed". The factory setting is "Off" (i.e., the time is included on the printout). If you select "On" for this menu item, the time stamp can be inserted by a higher-level controller or central computer to maintain consistent time stamping. This setting is especially important for communication with a PC.

Separating Block:

Dotted line, blank line (for the Weighing application). This block is automatically inserted before further information blocks are printed.

Block 3: Initialization Data

Which data is included in this block depends on the active application. It can include, for example, reference sample quantity, reference piece weight, target weight, etc. The block is terminated with a blank line. This block can only be activated for the standard printout. It cannot be selected for the printout of results.
Example: format of Block 3 (Counting application)

```
nRef      10 pcs
wRef +    0.035 kg
```

Block 4: Serial Number

Example: format of Block 4:

```
Ser.no.   1234567890
```

Block 5: Results

Which data is included in this block depends on the active application. Normally it includes gross, net and tare weights, followed by a blank line. The result is printed after this data; for example, the piece count. The block is terminated with a blank line.
Example: format of Block 3 (Counting application)

```
G# + 1.402 kg
T + 0.200 kg
N + 1.202 kg
```

```
Qnt      34 pcs
```

Data Interfaces

GMP-compliant Printouts

When the corresponding menu item is active, the measured result is bracketed on the printout by a GMP header and a GMP footer (GMP = “Good Manufacturing Practice”).

The GMP header precedes the first measured result. The GMP footer is printed either after each measured result (“ISO/GLP/GMP: For 1 application result,” menu item 7.11.2), or after the last result in a series of measurements (“ISO/GLP/GLP: For several application results,” menu item 7.11.3). To end a series of measured results, press and hold the **[F]** key (> 2 sec). In this case, the **[F]** symbol is displayed after the GMP header is printed and remains in the display until the GMP footer is printed.

If you toggle to a different weighing instrument (Combics 2 only) while a GMP printout of several measured results is being generated, the GMP footer for the weighing instrument used up to that point is generated when you press **[F]**. The GMP header for the other weighing instrument is included on the next printout generated.

A GMP-compliant printout is generated automatically at the conclusion of calibration/adjustment routines, as well as when you set or clear a preload.

If you use a label printer for GMP-compliant printouts and menu item 7.11.3 is active, the header and footer are printed on two different labels. To generate GMP-compliant printouts on labels, select menu item 7.11.2.

Three examples of GMP headers and one example of a footer are shown in the following. On Combics 1 models, the “date and time” line is not included.

Weighing platform WP1:

```
-----
14.01.2002      09:43
Model CW2P1-30ED-LCE
Ser.no.      12345678
Vers.       1.1007.12.1
BVers.      01-25-01
-----
```

Dotted line
Date/time ¹⁾
Combics model
Combics serial no.
Software release for applications
Software release for basic version
Dotted line

Weighing platform WP2 (xBPI protocol): ²⁾

```
-----
14.01.2002      09:45
Model CW2P1-30ED-LCE
Ser.no.      12345678
Vers.       1.1007.12.1
BVers.      01-25-01
Type        IS12000S
Ser.No.     12345678
-----
```

Dotted line
Date/time ¹⁾
Combics model,
Combics serial no.
Software release for applications
Software release for basic version
Platform model
Platform serial no.
Dotted line

Weighing platform WP2 (SBI protocol): ²⁾

```
-----
14.01.2002      09:45
Model CW2P1-30ED-LCE
Ser.no.      12345678
Vers.       1.1007.12.1
BVers.      01-25-01
Type        SBI
-----
```

Dotted line
Date/time ¹⁾
Combics model
Combics serial no.
Software release for applications
Software release for basic version
(Platform model)
Dotted line

GMP footer:

```
-----
14.01.2002      09:45
Name :
-----
```

Dotted line
Date/time ¹⁾
Field for operator signature
Blank line
Dotted line

¹⁾ Not applicable for Combics 1 indicators

²⁾ Combics 2 indicators only

Sample Printouts

For details on the individual information blocks, see “Configuring Printouts” above. For details on configuring the header lines, refer to the chapter describing the particular application.

Weighing Application

There is no data for the “initialization data” block. If this block is enabled for the printout, a blank line is output.

```

      HEADER LINE 1
      HEADER LINE 2

14.01.2002      09:43
-----
G#      +      1.402 kg
T       +      0.200 kg
N       +      1.202 kg
-----

```

With weighing instrument serial number:

```

Ser.no.      80705337

G#      +      1.402 kg
T       +      0.200 kg
N       +      1.202 kg
-----

```

Counting Application

The “Initialization data” block contains the reference sample quantity and reference piece weight. The “Results” block contains gross, net and tare weights, as well as the calculated piece count.

```

-----
nRef      10 pcs
wRef      +      0.035 kg

G#      +      1.402 kg
T       +      0.212 kg
N       +      1.190 kg

Qnt      34 pcs
-----

```

Neutral Measurement Application

The “Initialization data” block contains the reference sample quantity and reference weight. The “Results” block contains gross, net and tare weights, as well as the calculated piece count.

```

Ref      2 o
wRef      +      1.200 kg

G#      +      14.700 kg
T       +      0.300 kg
N       +      14.400 kg

Qnt      12 o
-----

```

Weighing in Percent Application

The “Initialization data” block contains the reference percentage and reference weight. The results block shows gross, net and tare weights, as well as the percentage, which is shown as either the loss or the residual amount.

```

Percentage = residue:
-----
pRef      100 %
Wxx%      +      2.100 kg

G#      +      1.859 kg
T       +      0.200 kg
N       +      1.659 kg

Prc      79 %
-----

```

```

Percentage = loss:
-----
pRef      100 %
Wxx%      +      2.100 kg

G#      +      0.641 kg
T       +      0.200 kg
N       +      0.441 kg

D      21 %
-----

```

Checkweighing Application

The “Initialization data” block contains the nominal, minimum and maximum weights. The “Results” block always contains the gross, net and tare weights. The other results can be displayed in one of two ways:

- Result = Weight:
The deviation from the nominal weight is given both as a percentage and as an absolute (weight) value, whether the result lies within the tolerance limits or not.
- Result = Threshold status:
If the result lies within the tolerance limits, the printout shows the deviation from the nominal weight both as a percentage and as an absolute (weight) value, just as in the “Weight” printout mode described above.
If the result is outside the tolerance limits, the last line of the printout indicates the status as follows:

Result in “OK” range; “Weight” or “Threshold” printout:

```

-----
Setp      +      1.300 kg
Min       +      1.235 kg
Max       +      1.365 kg

G#      +      1.312 kg
T       +      0.000 kg
N       +      1.312 kg

Lim       +      0.92 %
W.Diff+   +      0.012 kg
-----

```

Result outside (over) the “OK” range; “Threshold” printout:

```

-----
Setp      +      1.300 kg
Min       +      1.235 kg
Max       +      1.365 kg

G#      +      1.400 kg
T       +      0.000 kg
N       +      1.400 kg

Stat      HH
-----

```

Data Interfaces

Classification Application

The "Initialization data" block contains the upper limits of Classes 1 through 4. The "Results" block contains gross, net and tare weights, as well as the class that the sample belongs to (1 through 5, where Class 5 means that the upper limit of Class 4 was exceeded).

```

-----
Lim1 + 10.000 kg
Lim2 + 11.000 kg
Lim3 + 12.000 kg
Lim4 + 13.000 kg

G# + 9.700 kg
T + 0.000 kg
N + 9.700 kg

Class 1
-----

```

Animal Weighing Application

The "Initialization data" block contains the number of measured values that averaging is based on. The "Results" block contains the tare weight and the mean value.

```

-----
mDef 8

T + 0.000 kg
x-Net + 4.202 kg
-----

```

Net-Total Formulation Application

The "Initialization data" block is empty. If this block is enabled for the printout, a blank line is output.

Which data is contained in the "Results" block value depends on the program operating status at the time of printing.

The following options are available:

- Total/results printout
After **[CF]** is pressed
(tare memory is cleared)
- Individual/components printout
After **[OK]** is pressed
(component is stored in tare memory)
- Standard
After **[F]** is pressed (component is not stored in tare memory)

"Total" printout:

```

-----
n 3
S-Comp+ 3.400 kg
Cont.T+ 0.200 kg
-----

```

Component printout (menu item 3.17.3)

When the components printout is configured, the header is printed only once, followed by all components.

If you are using a label printer, make sure a single label is large enough for the list of all components. For printer models YDP011S and YDP041S, you can configure manual form feed in the operating menu. If the corresponding setting is active, you can activate "form feed" manually. With the YDP021S printer, form feed is automatic after each print command (fixed setting).

Example with 2 components

```

          HEADER LINE 1
          HEADER LINE 2
14.01.2002 09:43
-----
Cmp001+ 1.200 kg

Cmp002+ 2.000 kg

```

Component printout

(menu item 3.17.2)

The entire standard printout is generated for each component.

Example for the second component:

```

          HEADER LINE 1
          HEADER LINE 2
14.01.2002 09:46
-----
Cmp002+ 2.000 kg

```

Standard printout

Example before the 2nd component is stored:

```

G# + 4.400 kg
T + 0.200 kg
T2 + 4.200 kg
N + 0.000 kg

```

Totalizing Application

The "Initialization data" block is empty. If this block is enabled for the printout, a blank line is output.

Which data is contained in the "Results" block value depends on the program operating status at the time of printing.

The following options are available:

- Printout of results
After **[CF]** is pressed
(totalizing memory is cleared)
- Individual/component printout of one transaction
After **[OK]** is pressed
(component is stored in tare memory)
- Standard printout
After **[F]** is pressed (component is not stored in tare memory)

"Total" printout:

```

-----
*G 9.200 kg
*N + 8.600 kg
n 3
-----

```

Component printout (menu item 3.17.3)

The header is printed only once, all transaction are printed one after the other. For printing on a label printer, see also "Component printout, Net-Total."

Example with 2 transactions:

```

          HEADER LINE 1
          HEADER LINE 2
14.01.2002 09:43
-----
G# + 1.400 kg
T + 0.200 kg
N + 1.200 kg
n 1

G# + 3.400 kg
T + 0.200 kg
N + 3.200 kg
n 2

```

Component printout
(menu item 3.17.2)

The entire standard printout is generated for each component.

Example: 2. Print second transaction:

```
      HEADER LINE 1
      HEADER LINE 2
14.01.2002      09:43
-----
G#      +      2.400 kg
T      +      0.200 kg
N      +      2.200 kg
n              2
```

Standard printout

The transaction counter value is not printed.

Example: 2. Print second transaction:

```
G#      +      2.400 kg
T      +      0.200 kg
N      +      2.200 kg
```

Print menu parameters:

All active menu item settings below the active menu level are printed.

```
-----
MENU
      SETUP.
WP1
-----
  1
  1.1
      1.1.2
      1.2.1
      1.3.2
  ...
  1.18
  1.18.1
  CAL
      10.000 kg
```

etc.

GMP-compliant Printouts

Linearization record:

```
-----
14.01.2002      13:00
Model CW2P1-30ED-LCE
Ser.no.      12345678
Vers.      1.1007.12.1
BVers.      01-25-01
-----
```

Linearization

```
Wt.1 +      7.00 kg
Wt.2 +     15.00 kg
Wt.3 +     22.00 kg
Wt.4 +     30.00 kg
      completed
```

```
-----
14.01.2002      13:02
Name :
```

Calibration/adjustment record:

```
-----
14.01.2002      13:50
Model CW2P1-30ED-LCE
Ser.no.      12345678
Vers.      1.1007.12.1
BVers.      01-25-01
-----
```

```
External calibration
Nom. +     30.000 kg
Diff. -      0.003 kg
External adjustment
Diff. +      0.000 kg
-----
```

```
14.01.2002      13:52
Name :
```

“Set preload” record:

```
-----
14.01.2002      13:50
Model CW2P1-30ED-LCE
Ser.no.      12345678
Vers.      1.1007.12.1
BVers.      01-25-01
-----
```

Set preload

completed

```
-----
14.01.2002      13:52
Name :
```

“Clear preload” record:

```
-----
14.01.2002      13:50
Model CW2P1-30ED-LCE
Ser.no.      12345678
Vers.      1.1007.12.1
BVers.      01-25-01
-----
```

Clear preload

completed

```
-----
14.01.2002      13:52
Name :
```

Weighing printout with multiple results;
example with 2 results:

```
-----
14.01.2002      09:43
Model CW2P1-30ED-LCE
Ser.no.      12345678
Vers.      1.1007.12.1
BVers.      01-25-01
-----
```

```
      HEADER LINE 1
      HEADER LINE 2
14.01.2002      09:43
-----
```

```
G#      +      2.40 kg
T      +      0.20 kg
N      +      2.20 kg
-----
```

```
      HEADER LINE 1
      HEADER LINE 2
14.01.2002      09:44
-----
```

```
G#      +      3.40 kg
T      +      0.30 kg
N      +      3.10 kg
-----
```

```
14.01.2002      09:45
Name :
```

Error Codes

Error codes are shown on the main display. There are three types of error:

- Dynamic errors are indicated until the error is corrected, by an error code (e.g. *InF 0 1*).
- Temporary errors are indicated for 2 seconds (e.g., *InF 0 7*)
- "Fatal" errors are displayed continuously (e.g., *Err 10 1*) until the indicator is switched off and back on again.

Error Code	Cause	Solution
No display segments shown	No power connection	Check power supply
-----	Key pressed is not currently available	
H	Weighing capacity exceeded	Unload the weighing instrument
L or Err 54	Load plate/weighing pan is not on the weighing instrument	Place the load plate/weighing pan on the weighing instrument
Err 10 1- 104	Key is stuck Key pressed when switching on the Combics	Release key or Contact your local Sartorius Service Center
Err 320	Operating program memory (EEPROM) defective	Contact your local Sartorius Service Center
Err 335	Verified platform not compatible with terminal	Connect a compatible weighing platform
Err 340	Operating parameter (EEPROM) error	Turn the weighing instrument off, then back on again. If this error code remains displayed, please contact your local Sartorius Service Center
Err 34 1	Data lost from RAM, battery needs to be recharged	Leave the weighing instrument power on for at least 10 hrs.
Err 343	Loss of data in the memory area for transaction numbers in external Alibi memory modules	Contact your local Sartorius Service Center
InF 0 1	Data output not compatible with output format	Change the configuration in the Setup menu
InF 02	Calibration/adjustment condition not met, e.g., - the weighing instrument was not tared - the weighing instrument is loaded	Calibrate only when zero is displayed Press  to tare Unload the weighing instrument
InF 03	Calibration/adjustment could not be completed within a certain time	Allow the weighing instrument to warm up again and repeat the adjustment process
InF 06	Internal calibration weight defective	Contact your local Sartorius Service Center
InF 07	Function not allowed in weighing instruments verified for use in legal metrology	Contact your local Sartorius Service Center for information on having the settings changed
InF 08	The load on the weighing instrument is too heavy to zero the readout	Check whether "tare/zero with power on" is set (1.12)
InF 09	Taring is not possible when the gross weight is < zero	Zero the weighing instrument
InF 10	Tare key is blocked when there is data in the tare memory	The data stored for the application program (Combics 2 only) must be deleted (clear the memory) before taring.
InF 18	Preload is too light	
InF 19	Preload is too heavy	
InF 29	Minimum load not reached	Define a lower value for the minimum load (in the Application settings, under 3.6)
InF 30	BPI ID (BPI byte) in active weighing instrument not deleted (cannot deactivate XBPI mode in COM1)	Restore factory settings for device parameters in the active weighing instrument
InF 3 1	Interface handshake not completed	Send XON, CTS
InF 7 1	Cannot store the current weight value (e.g., if control limits are too low or too high)	None
InF 72	Cannot store the current weight value (e.g., the transaction counter has reached its limit)	None
InF 73	Data not found or unreadable	Contact your local Sartorius Service Center
InF 74	Function is blocked (e.g., menu is locked)	None
no !!P	No weighing platform connected	Contact your local Sartorius Service Center

Care and Maintenance

Service

Regular servicing by a Sartorius technician will extend the service life of your Combics indicator and ensure its continued weighing accuracy. Sartorius can offer you service contracts, with your choice of regular maintenance intervals ranging from 1 month to 2 years.

The optimum maintenance interval depends on the operating conditions at the place of installation and on the individual tolerance requirements.

Repairs

- △ Disconnect defective equipment from power immediately (unplug the equipment from the wall outlet (mains supply)). Repairs may be performed only by authorized Sartorius service technicians using original Sartorius parts. Repairs performed by untrained persons may result in considerable hazards for the user. Important Note: If the equipment is still under warranty, send the entire indicator to the factory for repairs.

- △ If a cable or cable gland is damaged or defective, replace the cable as a complete unit with all its connectors.

- △ Do not open the indicator while it is carrying current. Allow at least 10 seconds to elapse after disconnecting the equipment from power before opening the equipment housing. Proper fitting of all surfaces is essential for the IP rating of the housing; for this reason the device must be opened and closed by a certified technician.

Cleaning

- △ Disconnect the indicator from power (unplug the from the wall outlet (mains supply) and disconnect any data cables.
- △ Make sure that no liquid enters the indicator housing.
- △ Do not use any aggressive cleaning agents (solvents or similar agents).
- △ Do not wash down the equipment with water or dry it with compressed air; this is not permitted.
- Clean the indicator using a piece of cloth which has been wet with a mild detergent (soap).
- If used in the food industry, use a cleaning agent suitable for the particular working environment.
- After cleaning, wipe down the indicator with a soft, dry cloth.

- If the weighing platform is installed in a pit, make sure that no dirt accumulates between the edge of the pit and the weighing platform. This will prevent measuring errors.
- Observe your company's internal regulations and standard industry guidelines with regard to cleaning intervals and cleaning agents.
- Regularly remove all dirt from the floor of the pit.

Cleaning Stainless Steel Surfaces

Clean all stainless steel parts regularly. Use a damp cloth or sponge to clean stainless steel parts on the weighing instrument. You can use any household cleaning agent that is suitable for use on stainless steel. Clean stainless steel surfaces by wiping them down. Then rinse the equipment thoroughly, making sure to remove all residues. Afterwards, allow the equipment to dry. If desired, you can apply oil to the cleaned surfaces as additional protection.

Solvents are permitted for use only on stainless steel parts.

Cleaning the Interior of the Weighing Platform

- If dirt enters the interior of the weighing platform, the load plate has to be removed. Particular caution is advised when working with models larger than 1000 × 1000 mm.
- Blow out the interior with pressurized air or rinse with a weak water jet (max. 60°C). Make sure no dirt enters the gap in the overload safety mechanism (the gap between the load cell and the screwed-on plate).

Corrosive Environment

- > Remove all traces of corrosive substances from the weighing platform on a regular basis.

Replacing the Dust Cover

- > Replace damaged dust covers.
- Place the new dust cover on the indicator and press down on the front and back along the edges until the cover is firmly seated.

Safety Inspection

Safe operation of the device is no longer ensured when:

- there is visible damage to the device or power cord
- the built-in power supply no longer functions properly
- the device has been stored for a relatively long period under unfavorable conditions (e.g., extreme moisture)

If there is any indication that safe operation of the device is no longer warranted:

- Disconnect the equipment from power (unplug the equipment from the wall outlet (mains supply) and lock it in a safe place to ensure that it cannot be used.
- Notify your nearest Sartorius Service Center or the International Technical Support Unit based in Goettingen, Germany.

Maintenance and repair work may be performed only by authorized Sartorius service technicians who:

- have access to the required service and maintenance manuals, and
- have attended the relevant service training courses.
- △ The seals affixed to this equipment indicate that the equipment may be opened only by authorized service technicians, to ensure safe and trouble-free operation of the equipment and to maintain the conditions for warranty coverage.

Recycling

Packaging that is no longer required must be disposed of at the local waste disposal facility. The packaging is made of environmentally friendly materials that can be used as secondary raw materials.



The equipment, including accessories and batteries, does not belong in your regular household waste.

The EU legislation requires its Member States to collect electrical and electronic equipment and dispose of it separately from other unsorted municipal waste with the aim of recycling it.

In Germany and many other countries, Sartorius AG takes care of the return and legally compliant disposal of its electrical and electronic equipment on its own. These products may not be placed with the household waste or brought to collection centers run by local public disposal operations – not even by small commercial operators.

For disposal in Germany and in the other Member States of the European Economic Area (EEA), please contact our service technicians on location or our Service Center in Goettingen, Germany:

Sartorius AG
Service Center
Weender Landstrasse 94-108
37075 Goettingen, Germany

In countries that are not members of the European Economic Area (EEA) or where no Sartorius affiliates, subsidiaries, dealers or distributors are located, please contact your local authorities or a commercial disposal operator.

Prior to disposal and/or scrapping of the equipment, any batteries should be removed and disposed of in local collection boxes.

Sartorius AG, its affiliates, subsidiaries, dealers and distributors will not take back equipment contaminated with hazardous materials (ABC contamination) – either for repair or disposal. Please refer to the accompanying leaflet/manual or visit our Internet website (www.sartorius.com) for comprehensive information that includes our service addresses to contact if you plan to send your equipment in for repairs or proper disposal.

CE Marking

This equipment fulfills the requirements specified by the Council Directives of the European Union:

Council Directive 2004/108/EEC
“Electromagnetic compatibility (EMC)”

Applicable European Standards:

Limitation of emissions:

In accordance with EN 61326-1,
Class B (residential areas)

Defined immunity to interference:

In accordance with EN 61326-1
(Minimum inspection requirements,
unmonitored operation)

Important note:

The operator shall be responsible for any modifications to Sartorius equipment and for any connections of cables or equipment not supplied by Sartorius and must check and, if necessary, correct these modifications and connections.

On request, Sartorius will provide information on the minimum operating specifications (in accordance with the standards listed above for defined immunity to interference).

Council Directive 2006/96/EEC

“Electrical equipment designed for use within certain voltage limits”

Applicable European Standards:

EN61010-1: 2001

Safety requirements for electrical equipment for measurement, control and laboratory use

Part 1: General requirements

If you use electrical equipment in installations and under ambient conditions requiring higher safety standards, you must comply with the provisions as specified in the applicable regulations for installation in your country.

Overview

Common Specifications CW* P | S | FS

Maximum readability	31,250 scale intervals (not in legal metrology)
Accuracy class	Ⓜ (on models ...-CE)
Verification scale intervals	≤3000e, (single-range scale) or 2 × 3000e (multiple range scale acc. to EN45501)
Digital protective interface	acc. to EN45501
Data interface	Bi-directional RS-232C interface with control outputs (standard equipment)
Additional data interface	optional
Display	20 mm LCD, 7-segment plus status symbols, backlit
Housing:	
Material	AISI 304 stainless steel
Dust and water protection acc. to EN60529	CW1P, CW1NP, CW2P: IP44 (optional IP65) CW1S, CW1NS, CW2S: IP67
Operating temperature range	-10°C to +40°C
Power supply	100–240 VAC (-15/+10 %), 50–60 Hz, max. 17 W/23 VA
DC Supply	optional 15.5–24 VDC (±10%), max. 12 W
AC Supply	optional 13–17 VAC (±10%), 50–60 Hz, max. 12 W
Battery operations	External rechargeable battery pack YBR10Z
Emissions	Acc. to EN61326+A1 Class B (IEC 61326+A1)
Immunity to interference	Acc. to EN61326+A1, industrial environment (IEC 61326+A1)
Electrical safety	Acc. EN61010-1 (IEC 1010-1), EN60950 (IEC 950)

Model-specific Specifications (Platform Specifications)

Model code:	CW...-L	CW...-I	CW...-LCE	CW...-NCE (2 x 3000e)			
Type/Approval	Sartics (D04-09-015) + TN (D09-03.13)						
	Readability	Readability	Readability	Weighing range 1	Weighing range 2		
Weighing capacity	15000d	30000d	1x3000e	Maximum capacity	Readability	Maximum capacity	Readability
3 kg	0.2 kg	0.1 g	1 g	1.5 kg	0.5 g	3 kg	1 g
6 kg	0.5 kg	0.2 g	2 g	3 kg	1 g	6 kg	2 g
15 kg	1 kg	0.5 g	5 g	6 kg	2 g	15 kg	5 g
30 kg	2 kg	1 g	10 g	15 kg	5 g	30 kg	10 g
60 kg	5 kg	2 g	20 g	30 kg	10 g	60 kg	20 g
150 kg	10 kg	5 g	50 g	60 kg	20 g	150 kg	50 g
300 kg	20 kg	10 g	100 g	150 kg	50 g	300 kg	100 g
600 kg	50 kg	20 g	200 g	300 kg	100 g	600 kg	200 g
1500 kg	100 kg	50 g	500 g	600 kg	200 g	1500 kg	500 g
3000 kg	200 kg	100 g	1000 g	1500 kg	500 g	3000 kg	1000 g

Model-specific Specifications

- CH = Combics High Resolution
- 1N = Combics 1N Indicator (CIS1N)
- 3 = Combics 3 Indicator (CIS3)
- E = Epoxy
- G = Galvanized

Type Designation

Here, we'll show you an example of how to put together order numbers. CW1P1-60 FE-LCE means the following:

Complete Combics scale with indicator 1
 With one load cell
 A maximum, single-range weighing capacity of 60 kg
 A platform size of 500 x 400 mm
 A resolution of 3,000 e for accuracy class III (CW1P...);
 (...1...);
 (...60...);
 (...FE...); and
 (...LCE)

Complete Combics scale



Indicator with 20 mm LCD, backlit; RS-232C interface port as a standard feature; port for optional battery operation. Indicator material: stainless steel
 Type of protection: IP44



With selectable application programs. Indicator with 20 mm LCD, backlit; integrated LEDs (red-green-yellow) for checkweighing or classification; RS-232C interface port as a standard feature; port for bar code scanner or optional battery pack. Applications: weighing; counting; checkweighing; classification into 3 or 5 classes; totalizing; net-total formulation; filling; weighing in percent; neutral measurement; animal weighing. Indicator material: stainless steel. Type of protection: IP44.



With selectable application programs. Dot-matrix display, backlit. Integrated LEDs (red-green-yellow) for checkweighing or classification; RS-232C interface port as a standard feature; port for bar code scanner or optional battery pack. Applications: weighing; counting; checkweighing; classification into 3 or 5 classes; totalizing; net-total formulation; filling; weighing in percent; neutral measurement; animal weighing. Indicator material: stainless steel. Type of protection: IP44.

Applications	Material Design	Number of load cells	Capacity (kg)	Platform size mm order code	Resolution
CW1	P	1	60	FE	LCE



1	3 kg	300 x 240	(DC)	L
1	6 kg	300 x 240	(DC)	15,000 d
1	15 kg	300 x 240	(DC)	
1	30 kg	400 x 300	(ED)	
1		500 x 400	(FE)	I
1	60 kg	400 x 300	(ED)	30,000 d
1		500 x 400	(FE)	
1		650 x 500	(GF)	
1		800 x 600	(IG)	LCE
1	150 kg	500 x 400	(FE)	3,000 e
1		650 x 500	(GF)	(verification
1		800 x 600	(IG)	scale
1	300 kg	650 x 500	(GF)	intervals)
1		800 x 600	(IG)	
4		1,000 x 1,000	(LL)	NCE
4		1,250 x 1,000	(NL)	2 x 3,000 e
4		1,500 x 1,250	(RN)	(verification
4		1,500 x 1,500	(RR)	scale
4		2,000 x 1,500	(WR)	intervals)
4	600 kg	1,000 x 1,000	(LL)	
4		1,250 x 1,000	(NL)	
4		1,500 x 1,250	(RN)	
4		1,500 x 1,500	(RR)	
4		2,000 x 1,500	(WR)	
4	1.500 kg	1,000 x 1,000	(LL)	
4		1,250 x 1,000	(NL)	
4		1,500 x 1,250	(RN)	
4		1,500 x 1,500	(RR)	
4		2,000 x 1,500	(WR)	
4	3.000 kg	1,000 x 1,000	(LL)	
4		1,250 x 1,000	(NL)	
4		1,500 x 1,250	(RN)	
4		1,500 x 1,500	(RR)	
4		2,000 x 1,500	(WR)	

CW2FS1-150FE-L, our example of a complete food scale looks like this:

Complete Combics Food Scale, stainless steel with indicator 2 with one load cell, a maximum, single-range weighing capacity of 150 kg, a platform size of 500 x 400 mm and a resolution of 15,000 digits

(CW2FS...),
(...1...),
(...150...),
(...FE...)
(...L)

Complete Combics Food Scales

CW1FS



Indicator with 20 mm LCD, backlit; RS-232C interface port as a standard feature; port for optional battery operation. Indicator completely made of stainless steel. Type of protection: IP67

CW1NFS



Keypad for entering identifiers and preset tare values. 20 mm LCD, backlit; RS-232C interface port as standard feature; port for optional battery operation. Made completely of stainless steel. Type of protection: IP67.

CW2FS



With selectable application programs. Indicator with 20 mm LCD, backlit; integrated LEDs (red-green-yellow) for checkweighing or classification; RS-232C interface port as a standard feature; port for barcode scanner or rechargeable battery pack.

Applications: weighing, counting, checkweighing, classification into 3 or 5 classes, totalizing, net-total formulation, filling, weighing in percent, neutral measurement, animal weighing. Indicator material: completely made of stainless steel. Type of protection: IP67.

Applications	Material Design	Number of Load Cells	Capacity (kg)	Platform Size mm Order Code	Readability in g*
CW2	FS	1	150	FE	-L -I -LCE -NCE
	1	3 kg	320x240	(DC)	0.2 0.1 1 0.5 1
	1	6 kg	320x240	(DC)	0.5 0.2 2 1 2
	1	15 kg	320x240	(DC)	1 0.5 5 2 5
	1	30 kg	400x300	(ED)	2 1 10 5 10
	1		500x400	(FE)	
	1	60 kg	400x300	(ED)	5 2 20 10 20
	1		500x400	(FE)	
1	150 kg	500x400	(FE)	10 5 50 20 50	

*Resolution: L=15,000 d, I=30,000 d, LCE=3,000 e (verification scale intervals), NCE=2x3,000 e (verification scale intervals for multiple range instruments)

Key to Model Designations

Model designations for high resolution Combics complete scales

CH1NE



Reference device

CH1NG



Information on metrological label

Model ID	Load	Readability range	Verification e=(g), d=(g)	Dimensions scale interval	Max (kg)	Min (g)
CH1NE						
-16ED/-H	16	0.1	-	400 × 300 × 120	16	- -
-16ED/-HCE	16	0.1	1	400 × 300 × 120	16	5 1
-34ED/-H	34	0.1	-	400 × 300 × 120	34	- -
-34ED/-HCE	34	0.1	1	400 × 300 × 120	34	5 1
-64ED/-S	64	1	-	400 × 300 × 120	64	- -
-64ED/-SCE	64	1	10	400 × 300 × 120	64	50 10
-64ED/-H	64	0.1	-	400 × 300 × 120	64	- -

CH1NG

-64FE/-S	64	1	-	560 × 450 × 95	64	- -
-64FE/-SCE	64	1	10	560 × 450 × 95	64	50 10
-1501G/-H	150	1	-	800 × 600 × 117	150	- -
-1501G/-HCE	150	1	10	800 × 600 × 117	150	50 10
-3001G/-H	300	2	-	800 × 600 × 117	300	- -
-3001G/-HCE	300	20	20	800 × 600 × 117	300	1000 20

CH*E

Application	Version/ Platform base	Weighing capacity	Platform dimensions	Resolution	Resolution Legal for trade version	Type and approval
CH1N	E	-16	ED	-H	-HCE	Type iso-Test+BFBF D97-09-018 +D09-096.30
	E	-34	ED	-H	-HCE	Type iso-Test+BFBF D97-09-018 +D09-096.30
	E	-64	ED	-S	-SCE	Type iso-Test+BFBF D97-09-018 +D09-096.30

Order code E: Base coated with epoxy resin; Order code ED: 400 × 300 mm

CH*G

Application	Version/ Platform base	Weighing capacity	Platform dimensions	Resolution	Resolution Legal for trade version	Type and approval
CH1N	G	-64	FE	-S	-SCE	Type iso-Test+HABD D97-09-018 +D09-95.18
	G	-150	1G	-H	-HCE	Type iso-Test+HCBF D97-09-018 +D09-96.30
	G	-300	1G	-H	-HCE	Type iso-Test+HCBF D97-09-018 +D09-96.30

G = galvanized/electroplated

Order code FE: 560 × 450 mm; Order code 1G: 560 × 450 mm

Resolutions for CH*E and CH*G:

Resolution	
H	Resolution > 100,000d, not verified for legal metrology
HCE	Verified for legal metrology at CE factory, single range class II, > 10,000e, e = 10d
S	Resolution > =60,000d, not verified for legal metrology
SCE	Verified for legal metrology at CE factory, single range class II, < 10,000e, e = 10d

Overview

CW Dimensions* (Scale Drawings)

Combics:

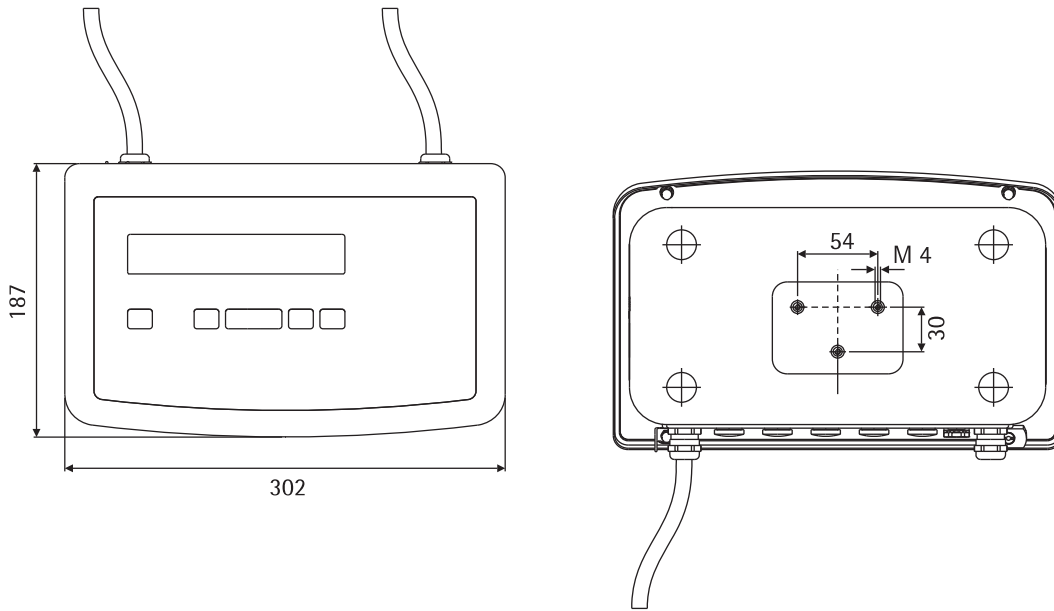

* in millimeters

Weighing Platforms:

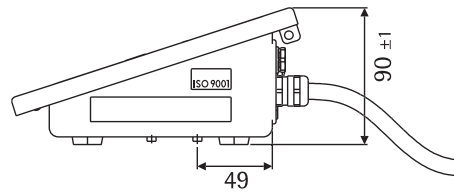
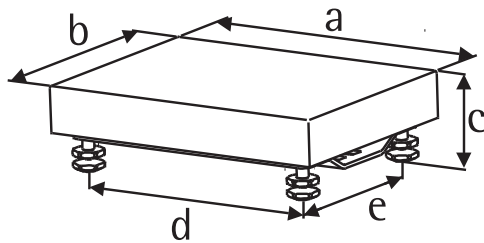

Standard and Stainless Steel Versions

Length	Width	Height: Standard version	Height: Stainless steel version	Distance between leveling feet (standard)		Distance between leveling feet (stainless steel)		Cable length
a	b	c	c	d	e	d	e	(m) approx.
(mm)	(mm)	(mm)	(mm)	(mm)	(mm)	(mm)	(mm)	
320	240	72	82	264	184	264	184	1.5
400	300	94	101	344	244	344	244	1.5
500	400	96	104	443	343	443	343	1.5 (painted) 3.0 (stainless steel)
650	500	145	90	530	434	550	400	3.0
800	600	145	90	680	534	700	500	3.0
800	800	90	90	604	604	604	604	6.0
1,000	800	90	90	804	604	804	604	6.0
1,000	1,000	90	90	804	804	804	804	6.0
1,250	1,000	90	90	1,054	804	1,054	804	6.0
1,500	1,250	90	90	1,304	1,054	1,304	1,054	6.0
1,500	1,500	90	90	1,304	1,304	1,304	1,304	6.0
2,000	1,500	100	100	1,804	1,304	1,804	1,304	6.0

CH Platform Dimensions (Scale Drawings)

CH*G

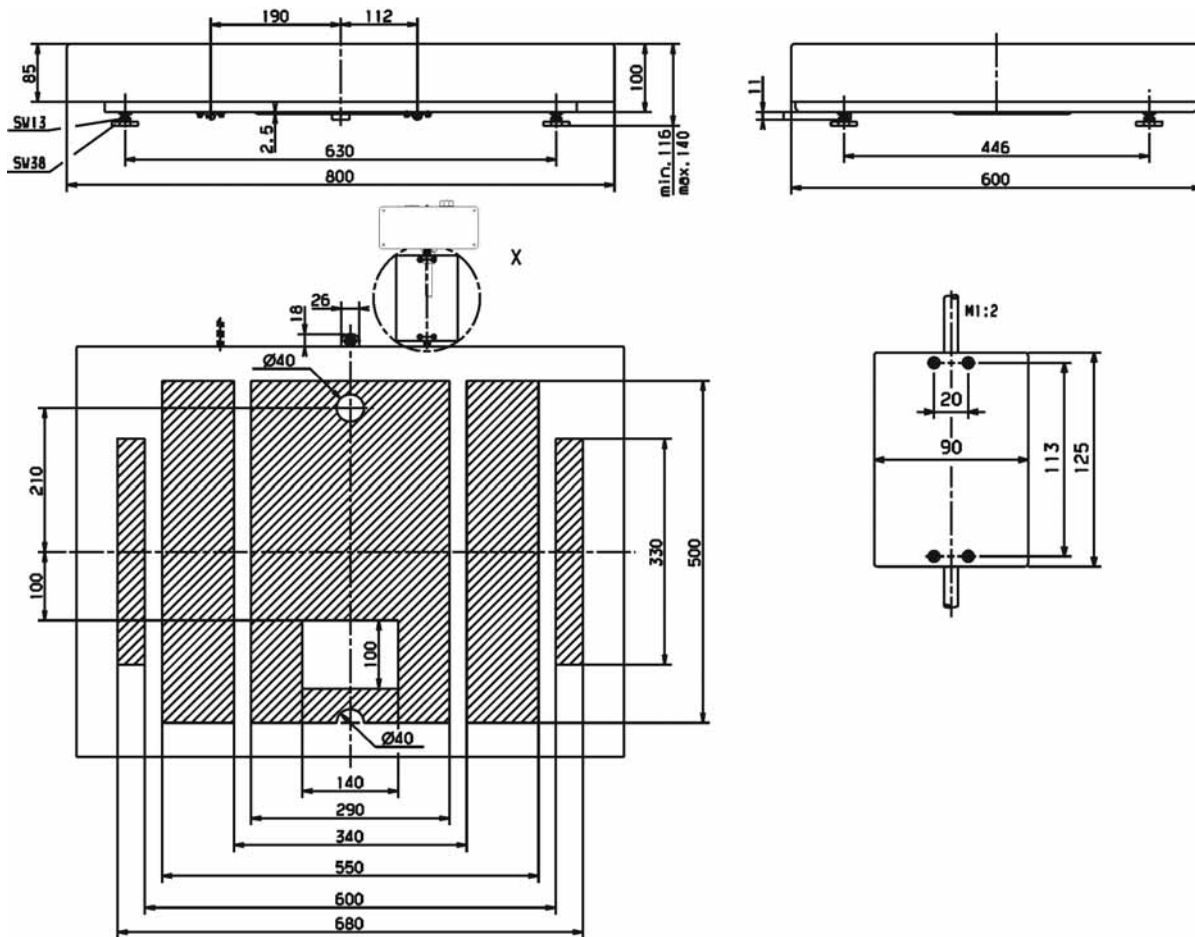

CH*E

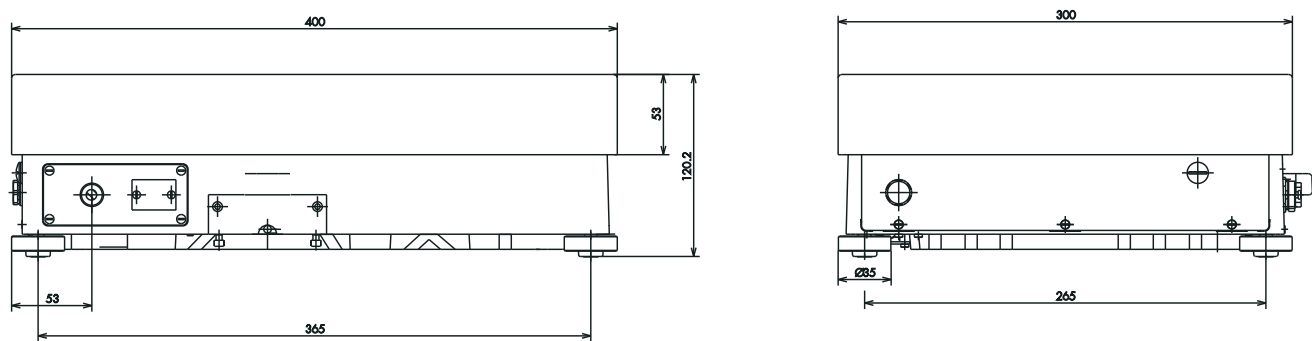

Accessories

Combics full-range scales:

Product	Order No.
Optional Interface	
Interface module (RS-232C) for UniCOM data interface	YD001C-232
Interface module (RS-485/422) for UniCOM data interface	YD001C-485
Profibus-DP module for UniCOM interface	YD001C-DP
Bluetooth® wireless interface module with antenna outside the housing	YD001C-BT
Analog current output, 0-20 mA, 4-20 mA, 0-10 V, 16-bit	YDA01C-20MA

Printers and Printer Accessories

Verifiable printer with functions for date, time and statistical evaluations	YDP03-OCE
Printer paper (5 rolls; length per roll: 50 m) for data printer	6906937
Replacement ink ribbon cartridge for printer	6906918

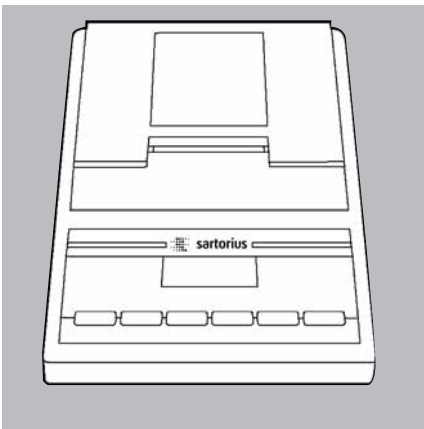

Verifiable strip and label printer with thermal print head, paper width 101 mm, with adapter cable (12-pin round male connector) and external power supply Adapter cable YCC01-01CISLM3 required for CW.P models. Adapter cable YCC02-R12F6 required for CW.S models.	YDP12IS-OCE-UV
Printer paper (1 roll) for YDP12IS -OCE printer, 101 mm × 75 m, thermo paper	69Y03196
Labels for YDP12IS-OCE printer, extra large, 101 × 127 m, 305 labels	69Y03195

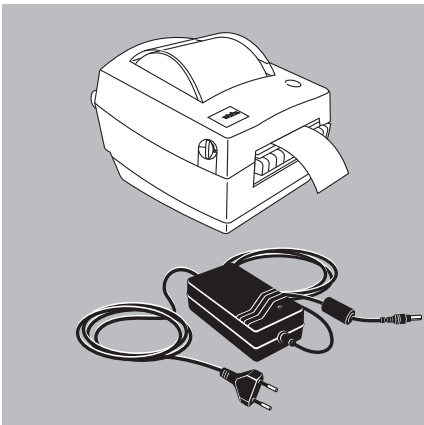

Verifiable strip and label printer with thermal print head, Paper width 60 mm, with adapter cable (12-contact round male connector) and external power supply. Adapter cable YCC01-01CISLM3 required for CW..P models. Adapter cable YCC02-R12F6 required for CW..S models.	YDP04IS-OCE-UV
Printer paper (3 rolls) for YDP02/04IS-OCE, 60 mm + 75 m, thermo paper	69Y03090
Labels for YDP02/04IS-OCE small, 58 + 30 mm, 1000 labels	69Y03092
Labels for YDP02/04IS-OCE medium, 58 + 76 mm, 500 labels	69Y03093
Labels for YDP02/04IS-OCE large, 58 + 100 mm, 350 labels	69Y03094
Cable for direct connection of YDP02/04IS-OCE to Combics CW.P models CISL indicator	YCC01-01CISLM3

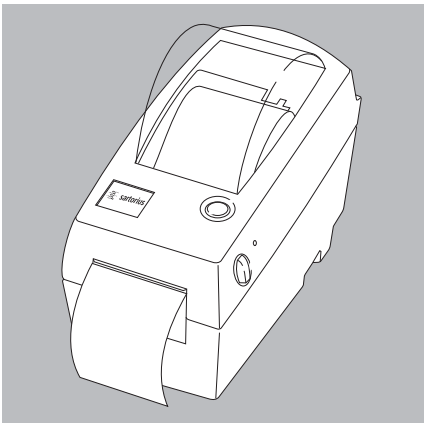

* not for use in legal metrology

Product	Order No.
Electrical Accessories	
External red/green/red display for CW.P models	YRD11Z
Second display* for CW.P models	YRD02Z
Remote display*, 7-segment, e. g. up to 45 mm characters	On request
Bar code scanner, 120 mm scanning width, with cable for connection to Combics CW.P indicators	YBR02CISL
Bar code scanner for CW.S models, adapter cable YCC02-R12F6	YBR02FC
Foot switch, incl. D-SUB 25-pin T-connector	YFS01
Hand switch, incl. D-SUB 25-pin T-connector	YHS02
External Alibi memory for electronic storage of weighing data	YAM01IS
Scanner for loading weighing data from PC, from YAM13IS	YAM02IS
Power supply for YAM01IS or YAM02IS	YAM11IS
Memory card for YAM01IS Alibi memory	YAM13IS
Cable for connecting Combics indicator to YAM01IS Alibi memory	YCC01-10CIM3
Cable for connecting (D-SUB 9-pin) YAM01IS Alibi memory to a PC (2 m)	69EM0012
Flow control for pumps with analog or digital pulse interface	YFC02Z-V2
Additional Accessories	
Dust covers (2 pcs)	YDC01CI
IP65 Kit for IP44 Combics	YAS01CISL
Anti-theft device	YTP01CI
Cable gland for Combics CW1S/CW4S models, IP67 protected	YAS04CIS
Mechanical Accessories	
Retainer plate for mounting indicator on platform (front-mounted indicator), made of AISI 304 stainless steel, for platform dimensions 240×300 mm	YDH11CWS
Installation kit for installing the Combics in a pit (with connecting hardware that lets you disconnect the indicator as desired)	YAS99I
Retainer for wall mounting, stainless steel	YDH02CIS
Floor-mounted column	YDH03CIP
Floor-mounted column, stainless steel	YDH03CIS
Base for installing floor-mounted column	YBP03CIP
Base for installing floor-mounted column, stainless steel	YBP03CIS
Retainer for bar code scanner, for attachment to floor-mounted column, bench stand or complete scale retainer	YBH01CWS
Plates for attaching printer to floor-mounted column or bench stand	YPP01CWS
Software	
Flexible formatting options for printouts (e.g., for bar codes with variable font size, graphics, etc.) – Ask your sales representative	Information available on request!
Sartorius WinScale scale driver software for Windows 95/98/2000/NT. Displays the scale readout on your PC monitor and provides secure memory for storing data that is subject to legal control. YCC01-09ISM5 RS-232 connecting cable required	YSW03
SartoConnect data transfer software for connecting your Sartorius scale to a computer running Windows 95/98/NT. This software lets you load the data recorded by your scale in a PC application program such as MS Excel or Access. Includes a cable for connecting the scale to a PC	YSC011

* not for use in legal metrology

Power Supply

24V industrial power supply module	YAS02CI
External rechargeable battery pack, up to 40 h operation, incl. charger	YRB10Z
Connecting cable (25-pin D-SUB) for YRB10Z battery pack (2 m)	YCC02-RB01
Connecting cable with cable gland for YRB10Z battery pack (2 m)	YCC02-RB02
Connecting cable with cable gland for car battery (2 m)	YCC02-CB02

Connecting Cables

Connecting cable with cable gland for YBR02FC bar code scanner ¹⁾	YCC02-BR02
Connecting cable with cable gland 9-pin D-SUB male connector, 6 m ¹⁾	YCC02-D09M6
Connecting cable with cable gland, 9-pin D-SUB female connector, 6 m ¹⁾	YCC02-D09F6
Connecting cable with cable gland, 25-pin D-SUB female connector, 1.5 m ¹⁾	YCC02-D25F6
Connecting cable with cable gland, 12-pin round male connector, 6 m ¹⁾	YCC02-R12M6
Connecting cable with cable gland, 12-pin round female connector, 1.5 m ¹⁾	YCC02-R12F6
Cable for YDA01C-20MA power interface, with open cable ends e.g., 5 × 5 m*	6906926
Cable for connecting a PC; 25-contact D-Sub, approx. 1.5 m	7358312
Cable for connecting a PC; 9-contact D-Sub, approx. 1.5 m	7358314
Cable for connecting an isi terminal or QA/QC or FB/FC scale; 25-pin D-Sub to 12-pin round connector	YCC01-02ISM3
Cable for connecting a scale with 25-contact D-Sub female connector (25-pin D-Sub male connectors on both ends)	YCCD1-01M3
Cable for connecting an IS weighing platform; 25-pin D-Sub male connector to 25-contact D-Sub female connector, 3 m	YCC01.03CISLM3

¹⁾ for stainless steel Combics models only (CW1S, CW1NS, CW2S)

Options

Set of stainless steel floor fasteners (2 fastening plates, 4 special dowel screws), stainless steel	YFP01CWS
Column for bench, painted, for attaching indicator Adjustable height	YDH01WTCWP
Column for bench, stainless steel, for attaching indicator Adjustable height	YDH01WTCWS
Set of castors (2 guide castors, 2 lockable castors) for bench	YRO01WTCW
Plate for bench column, for attaching indicator and printer	YPP01CWS
Retainer for bar code scanner, for attachment to bench column	YBH01CWS

Connecting an IS Weighing Platform to a Combics 2 Indicator

You can connect an IS weighing platform as WP2.

Characteristics:

- IS weighing platforms process weighing data independently of the indicator
- IS platforms can be internally adjusted
- ...-OCE models have a separate approval number, on a tag affixed to the cable
- Please observe the conditions described in the instruction manual for the platform connected

Platform Accessories for CW*:

Product	Order No.					
Dimensions	800 × 600 mm	1,000×1,000 mm	1,250×1,000 mm	1,500×1,250 mm	1,500×1,500 mm	2,000×1,500 mm
Length × Width						
Drive-on ramp, painted						
Order No.	YAR01CWP	YAR02CWP	YAR02CWP	YAR03CWP	YAR04CWP	YAR05CWP
Drive-on ramp, painted (tread plate)						
Order No.	YAR01CWPT	YAR02CWPT	YAR02CWPT	YAR03CWPT	YAR04CWPT	YAR05CWPT
Drive-on ramp, AISI 304 stainless steel						
Order No.	YAR01CWS	YAR02CWS	YAR02CWS	YAR03CWS	YAR04CWS	YAR05CWS
Drive-on ramp, AISI 304 stainless steel (tread plate)						
Order No.	YAR01CWST	YAR02CWST	YAR02CWST	YAR03CWST	YAR04CWST	YAR05CWST
Drive-on ramp, AISI 316 Ti stainless steel						
Order No.	YAR01CWS4	YAR02CWS4	YAR02CWS4	YAR03CWS4	YAR04CWS4	YAR05CWS4
Drive-on ramp, AISI 316 Ti stainless steel (tread plate)						
Order No.	YAR01CWST4	YAR02CWST4	YAR02CWST4	YAR03CWST4	YAR04CWST4	YAR05CWST4
Frame for pit installation, painted						
Order No.	YEG01CWP	YEG02CWP	YEG03CWP	YEG04CWP	YEG05CWP	YEG06CWP
Frame for pit installation, stainless steel						
Order No.	YEG01CWS	YEG02CWS	YEG03CWS	YEG04CWS	YEG05CWS	YEG06CWS
Length × Width	320 × 240 mm	400 × 300 mm	500 × 400 mm	650 × 500 mm	800 × 600 mm	
Roller conveyor, painted:						
Order No.	YRC01DCA	YRC01EDA	YRC01FEA	YRC01GFP	YRC01IGP	
Roller conveyor, AISI 304 stainless steel, for platform sizes:						
Order No.	YRC01DCS	YRC01EDS	YRC01FES	YRC01GFS	YRC01IGS	
Roller-ball load plate	-					
Order No.	-	YLP01CWS	YLP02CWS	YLP03CWS	YLP04CWS	
Column, painted, for attaching indicator to platform						
Order No.	YDH01CWP (Height 330 mm)	YDH02CWP (Height 500 mm) YDH03CWP (Height 750 mm) YDH03CWP (Height 750 mm)	YDH02CWP (Height 500 mm)	YDH03CWP (Height 750 mm)	-	
Column, AISI 304 stainless steel, for attaching indicator to platform						
Order No.	YDH01CWS (Height 330 mm)	YDH02CWS (Height 500 mm) YDH03CWS (Height 750 mm)	YDH02CWS (Height 500 mm)	-	-	
Bench, painted						
Order No.	-	YWT01CWP	YWT02CWP	YWT03CWP	YWT04CWP	
Bench, AISI 304 stainless steel						
Order No.	-	YWT01CWS	YWT02CWS	YWT03CWS	YWT04CWS	

Declaration of Conformity

CE Marking on Sartorius Equipment

In 1985, the Council of the European Community approved a resolution concerning a new approach to the technical harmonization and standardization of national regulations. The organization for monitoring compliance with the directives and standards concerning the CE marking is governed in the individual EU Member States through the implementation of the EC Directives adopted by the respective national laws. As of December 1993, the scope of validity for all EC Directives has been extended to the Member States of the European Union and the Signatories of the Agreement on the European Economic Area.

Sartorius complies with the EC Directives and European Standards in order to supply its customers with weighing instruments and related equipment that feature the latest technology and provide many years of trouble-free service.

The CE marking may be affixed only to weighing instruments and associated equipment that comply with the following Directives:

Council Directive 89/336/EEC

"Electromagnetic compatibility (EMC)"

Applicable European Standards

1. Electromagnetic compatibility

1.1 Reference to 89/336/EEC:

Official Journal of the European Communities, No. 2001/C 105/03

EN 61326-1 Electrical equipment for measurement, control and laboratory use EMC requirements

Part 1: General requirements
Defined immunity to interference:
Industrial areas, continuous, un-monitored operation
Limitation of emissions:
Residential areas, Class B

Important Note:

The operator shall be responsible for any modifications to Sartorius equipment and for any connections of cables or equipment not supplied by Sartorius and must check and, if necessary, correct these modifications and connections. On request, Sartorius will provide information on the minimum operating specifications (in accordance with the Standards listed above for defined immunity to interference).

Council Directive 73/23/EEC "Electrical equipment designed for use within certain voltage limits"

Applicable European Standards:

EN 60950	Safety of information technology equipment including electrical business equipment
EN 61010	Safety requirements for electrical equipment for measurement, control and laboratory use
Part 1:	General requirements

If you use electrical equipment in installations and under ambient conditions requiring higher safety standards, you must comply with the provisions as specified in the applicable regulations for installation in your country.

Weighing Instruments for Use in

Legal Metrology:

Council Directive 90/384/EEC

"Non-automatic weighing instruments"

This Directive regulates the determination of mass in legal metrology.

For the respective Declaration of Type Conformity for Sartorius weighing instruments verified for use as legal measuring instruments that have an EC Type-approval Certificate, see the instruction manual(s) for each weighing instrument connected or refer to the enclosed "Guide to Verification."

This Directive also regulates the performance of the EC verification by the manufacturer, provided that an EC Type-approval Certificate has been issued and the manufacturer has been accredited by an officer of a Notified Body registered at the Commission of the European Community for performing such verification. Sartorius complies with EC Directive No. 90/384/EEC for non-automatic weighing instruments, which has been in effect since January 1, 1993, within the Single European Market, as well as the accreditation of the Quality Management System of Sartorius AG by Lower Saxony's Regional Administrative Department of Legal Metrology (Niedersächsische Landesverwaltungsamt – Eichwesen) MEN from February 15, 1993. For additional information on the CE mark on Sartorius equipment, see Sartorius Publication No. W--0052-e93081.

"EC Verification" – A Service Offered by Sartorius

Our service technicians authorized to perform the verification of your weighing instruments that are acceptable for legal metrological verification can inspect and verify the metrological specifications at the place of installation within the Member States of the European Union and the Signatories of the Agreement on the European Economic Area.

Subsequent Verifications within the European Countries

The validity of the verification will become void in accordance with the national regulations of the country in which the weighing instrument is used. For information on verification and legal regulations currently applicable in your country, and to obtain the names of the persons to contact, please contact your local Sartorius office, dealer or service center.

For more information on the verification of weighing instruments for use in legal metrology, contact the Sartorius Service Center.

CE Declaration of Type Conformity to Directive No. 90/384/EEC

This declaration is valid for non-automatic electromechanical weighing instruments for use in legal metrology. These weighing instruments accepted for legal metrological verification have an EC Type-Approval Certificate. The model(s) concerned is(are) listed below along with the respective type, accuracy class, and number of the EC Type-Approval Certificate:

Model	Type weighing instrument	Type indicator	Accuracy class	EC type-approval certificate no.	Indicator test certificate no.
CW...-CE	SARTICS	TN	III	D04-09-015	D09-03.13

SARTORIUS AG declares that its weighing instrument types comply with the requirements of the Council Directive on non-automatic weighing instruments, no. 90/384/EEC of 20 June 1990; the associated European Standard "Metrological aspects of non-automatic weighing instruments," No. EN 45501; the amended, currently valid versions of the national laws and decrees concerning legal metrology and verification in the Member States of the European Union, the EU, and the Signatories of the Agreement on the European Economic Area, which have adopted this Council Directive into their national laws; and with the requirements stipulated on the Type-Approval Certificate for verification. This Declaration of Type Conformity is valid only if the ID label on the weighing instrument has the CE mark of conformity and the green metrology

sticker with the stamped letter "M" (the two-digit number in large print stands for the year in which the mark has been affixed):



If these marks are not on the ID label, this Declaration of Type Conformity is not valid. Validity can be obtained, for example, by submitting the weighing instrument for final action to be taken by an authorized representative of SARTORIUS AG. The period of validity of this Declaration of Type Conformity shall expire upon any tampering with, repair or modification of this weighing instrument or, in some Member States, on the date of expiration.

The operator of this weighing instrument shall be responsible for obtaining an authorized renewal of the verification, such as subsequent or periodic verification, of the weighing instrument for use as a legal measuring instrument.

Sartorius AG
37070 Goettingen, Germany
Signed in Göttingen, 01.11.2004

Dr. G. Maaz
(President of the Mechatronics Division)

J. Rehwald
(Head of the Production Department
Mechatronics / Weighing Technology Division)

Physikalisch-Technische Bundesanstalt

Braunschweig und Berlin

PTB



EG-Bauartzulassung

EC type-approval certificate

Zulassungsinhaber: Sartorius AG

Issued to:

Weender Landstr. 94-108
37075 Göttingen

Rechtsbezug:

In accordance with:

§ 13 des Gesetzes über das Mess- und Eichwesen (*verification act*) vom/dated 23. März 1992 (BGBl. I S. 711), zuletzt geändert am (*last amended on*) 02.02.2007 (BGBl. I S. 58), in Verbindung mit Richtlinie (*in connection with council directive*) 90/384/EWG, geändert durch (*amended by*) 93/68/EWG

Bauart:

In respect of:

Nichtselbsttätige elektromechanische Waage mit oder ohne Hebelwerk
Nonautomatic electromechanical weighing instrument with or without lever system

Typ / Type:

SARTICS

Max 0,5 kg ... 300 t

(III) $n \leq 10000$

(IIII) $n \leq 1000$

Option: Mehrbereichs- und Mehrteilungswaage
multi-interval and multiple range instrument

Zulassungsnummer:

Approval number:

D04-09-015 4. Revision

Gültig bis:

Valid until:

07.04.2014

Anzahl der Seiten:

Number of pages:

12

Geschäftszeichen:

Reference No.:

PTB-1.12-4031854

Benannte Stelle:

Notified Body:

0102

Im Auftrag

By order

Marcus Link



Braunschweig, 15.10.2007

Siegel
Seal

Die Hauptmerkmale, Zulassungsbedingungen und Auflagen sind in der Anlage enthalten, die Bestandteil der Revision der EG-Bauartzulassung ist. Hinweise und eine Rechtsbehelfsbelehrung befinden sich auf der ersten Seite der Anlage.
The principal characteristics, approval conditions and special conditions, if any, are set out in the Annex which forms an integral part of this Revision of the EC type-approval certificate. For notes and information on legal remedies, see first page of the Annex.

Physikalisch-Technische Bundesanstalt

Braunschweig und Berlin

PTB



Prüfschein

Test certificate

Ausgestellt für:

Sartorius AG

Issued to:

Weender Landstr. 94-108
37075 Göttingen

Prüfgrundlage:

EN 45501 (1992), Nr. 8.1, WELMEC-Dokument 2.1 (2001) EWG
Richtlinie 90/384/EWG, OIML R 76-1

In accordance with:

Gegenstand:

Anzeige- und Bedienterminal

Object:

Indication and operating device

Typ / Type:

TN , TN-X

Kennummer:

Serial number:

Prüfscheinnummer:

D09-03.13 2. Revision

Test certificate number:

D09-03.13 Revision 2

Datum der Prüfung:

Date of Test:

Anzahl der Seiten:

9

Number of pages:

Geschäftszeichen:

PTB-1.12-4017974

Reference No.:

Benannte Stelle:

0102

Notified Body:

Im Auftrag

By order

Braunschweig, 26.05.2005

Marcus Link



Siegel
Seal

R3-0025

Hinweise siehe erste Seite der Anlage, die Bestandteil des Prüfscheines ist.
For notes, see first page of the Annex which forms an integral part of the test certificate.

Plates and Markings

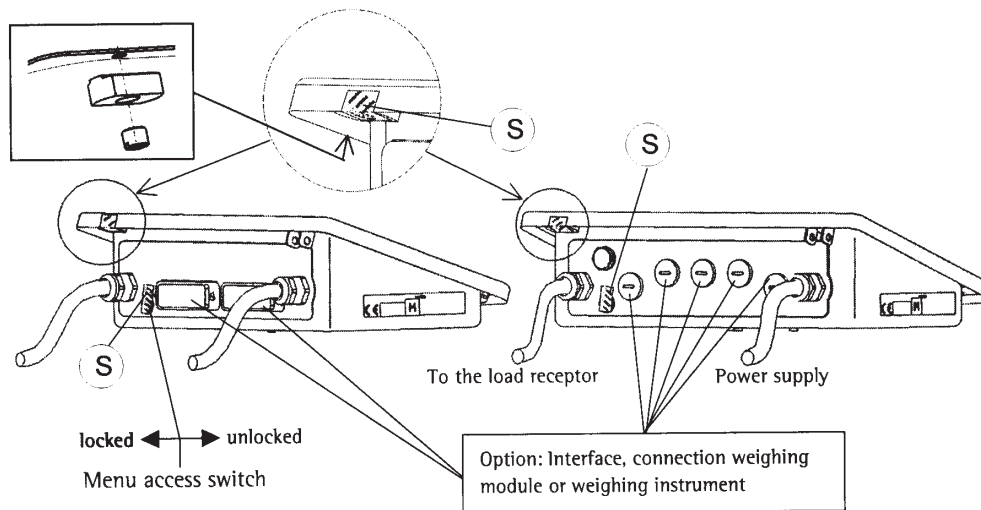
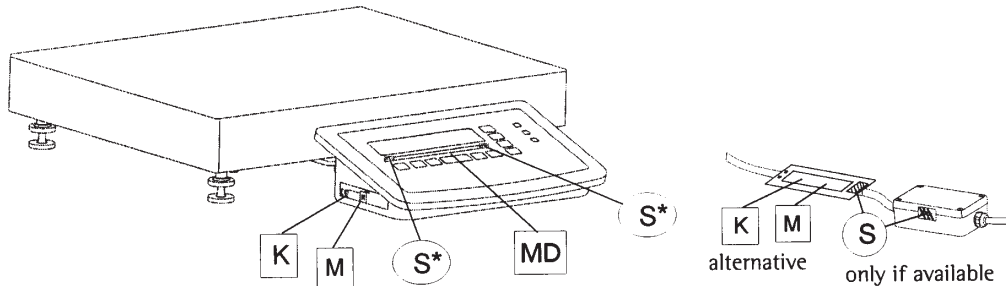

Alternative: Disconnectable connection between indicator and load receptors with strain-gauge load cells:

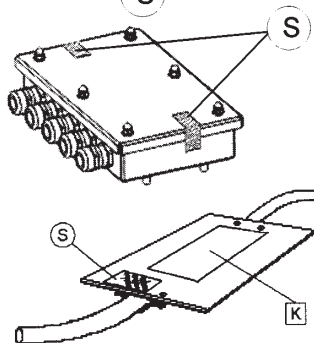
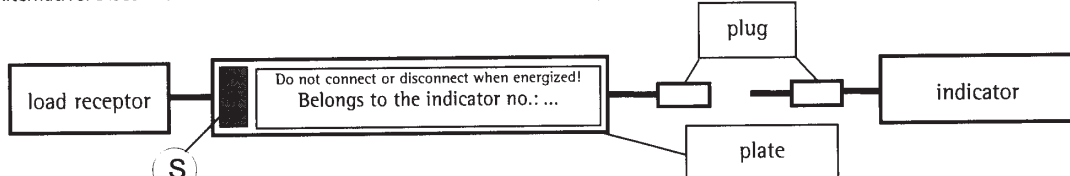

If there is a junction box between load receptor and electronic evaluation unit the junction box has to be secured against inadmissible manipulation.

Alternative place for the Descriptive Plate of the weighing instrument Handling in this case:

Affix the ID label of the weighing instrument to the delivered tag plate. Affix the ID tag plate to the data cable of the weighing module near the indicator. The verification officer or an authorized Sartorius representative must then seal the ID tag plate to the fastener.

- M** Mark for EC verification (green metrology sticker)
- K** Descriptive plate with CE-conformity
- MD** Metrological data: Max, Min and e

- S** Protective mark
- S*** Protective mark, only for detachable labels that remain intact

Example of descriptive plate of the already verified weighing instrument K



Example of plate with model designation of the terminal T

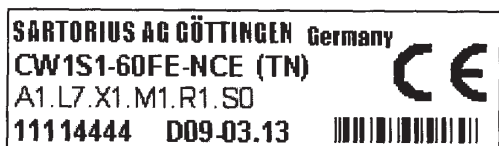

Example of plate with model designation of the platform



Example of label with metrological data MD



In case of using as an indicating and operator terminal for weighing modules

- The same locations for protective marks are valid at the terminal
- A disconnectable connection between indicating and operator terminal and weighing module needs not to be secured with a protective mark
- For verification the regulations (Protective marks at the weighing module, fixing of the descriptive plate, etc.) of the weighing module have to be disregarded. To connect a weighing module the menu access switch of the Terminal must be set to the "unlocked" position. The serial number of the weighing module is stored in the Terminal and the Terminal is only working with this weighing module. After connecting the weighing module the menu access switch of the Terminal must be set to the "locked" position for verification. The weighing module has its own descriptive plate. The requirements of the approval no. D97-09-018 are valid.
- As well the metrological data of the weighing module have to be attached under the display and have to be secured against manipulation.

Example of label with metrological data for a connected weighing module



CE Declaration of Type Conformity to Directive No. 90/384/EEC

This declaration is valid for non-automatic electromechanical weighing instruments for use in legal metrology. These weighing instruments accepted for legal metrological verification have an EC Type-Approval Certificate. The model(s) concerned is(are) listed below along with the respective type, accuracy class, and number of the EC Type-Approval Certificate:

Model	Weighing instrument type	Accuracy Class	EC Type Approval No.	In Conjunction with Test Certificate	
				Type	Certificate No.
CH...-OCE	iso-TEST	II	D97-09-018	BF BF	D09-96.30
CH...-OCE	iso-TEST	II	D97-09-018	HC BF	D09-96.30
CH...-OCE	iso-TEST	II	D97-09-018	HA BD	D09-95.18

SARTORIUS AG declares that its weighing instrument types comply with the requirements of the Council Directive on non-automatic weighing instruments, no. 90/384/EEC of 20 June 1990; the associated European Standard "Metrological aspects of non-automatic weighing instruments," No. EN 45501; the amended, currently valid versions of the national laws and decrees concerning legal metrology and verification in the Member States of the European Union, the EU, and the Signatories of the Agreement on the European Economic Area, which have adopted this Council Directive into their national laws; and with the requirements stipulated on the Type-Approval Certificate for verification. This Declaration of Type Conformity is valid only if the ID label on the weighing instrument has the CE mark of conformity and the green metrology

sticker with the stamped letter "M" (the two-digit number in large print stands for the year in which the mark has been affixed).

Example (date/year and number of the notified body may vary):



If these marks are not on the ID label, this Declaration of Type Conformity is not valid. Validity can be obtained, for example, by submitting the weighing instrument for final action to be taken by an authorized representative of SARTORIUS AG. The period of validity of this Declaration of Type Conformity shall expire upon any tampering with, repair or modification of this weighing instrument or, in some Member States, on the date of expiration. This declaration applies only to the unmodified weighing instrument without peripheral devices. The operator of this weighing instrument shall be responsible for obtaining an authorized renewal of the verification, such as subsequent or periodic verification, of the weighing instrument for use as a legal measuring instrument.

Sartorius AG
37070 Goettingen, Germany
Signed in Göttingen, 20.02.2008

Dr. G. Maaz
President of the Mechatronics Division

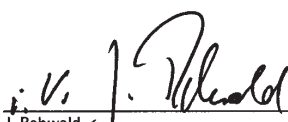
J. Rehwald
Head of the Production Department
Mechatronics/ Weighing Technology Division

Physikalisch-Technische Bundesanstalt

Braunschweig und Berlin

PTB



EG-Bauartzulassung

EC type-approval certificate

Zulassungsinhaber: Sartorius AG

Issued to:

Weender Landstr. 94-108
37075 Göttingen

Rechtsbezug:
In accordance with:

§ 13 des Gesetzes über das Mess- und Eichwesen (*verification act*) vom/dated 23. März 1992 (BGBl. I S. 711), zuletzt geändert am (*last amended on*) 02.02.2007 (BGBl. I S. 58), in Verbindung mit Richtlinie (*in connection with council directive*) 90/384/EWG, geändert durch (*amended by*) 93/68/EWG

Bauart:
In respect of:

Nichtselbsttätige elektromechanische Waage mit oder ohne Hebelwerk
Nonautomatic electromechanical weighing instrument with or without leverwork

Typ / Type:

iso-TEST

Genauigkeitsklasse/class **I**, **II**, **III**, **III** Max 2,1 g ... 300 t

Option: Mehrteilungswaage, Mehrbereichswaage

Multi-interval instrument, multiple range instrument

Zulassungsnummer:

D97-09-018 7. Revision

Approval number:

Gültig bis:

26.06.2017

Valid until:

Anzahl der Seiten:

18

Number of pages:

Geschäftszeichen:

PTB-1.12-4030179

Reference No.:

Benannte Stelle:

0102

Notified Body:

Im Auftrag

By order

Marcus Link



Braunschweig, 29.06.2007

Siegel
Seal

Die Hauptmerkmale, Zulassungsbedingungen und Auflagen sind in der Anlage enthalten, die Bestandteil der Revision der EG-Bauartzulassung ist. Hinweise und eine Rechtsbehelfsbelehrung befinden sich auf der ersten Seite der Anlage

The principal characteristics, approval conditions and special conditions, if any, are set out in the Annex which forms an integral part of this Revision of the EC type-approval certificate. For notes and information on legal remedies, see first page of the Annex.

Physikalisch-Technische Bundesanstalt

Braunschweig und Berlin



Prüfschein

Test certificate

Ausgestellt für:

Issued to:

Sartorius AG
Weender Landstraße 94 – 108
37075 Göttingen
Bundesrepublik Deutschland

Prüfgrundlage:

In accordance with:

EN 45501 (1992), Nr.8.1, OIML R 76-1 (1992)

Gegenstand:

Object:

Lastaufnehmer mit Wägezelle und Auswerteelektronik mit digitalem Ausgang als Modul einer elektromechanischen Waage zum Anschluß an geeignete Anzeige- und Bedienterminals
Load receptor with load cell and electronic device with digital output as module of an electromechanical weighing instrument for connection to suitable display- and operator-terminals
Typ / type **BA BF, BC BF, BD BF, BF BF, HC BF, MA BF und MD BF**

Kennummer:

Serial number:

Prüfscheinnummer:

Test certificate number:

D09-96.30 7. Revision / *Revision 7*

Datum der Prüfung:

Date of Test:

Anzahl der Seiten:

Number of pages:

12

Geschäftszeichen:

Reference No.:

1.14 – 02001430

Benannte Stelle:

Notified Body:

0102

Im Auftrag

By order

Link



Braunschweig, 2002-11-13

Siegel

Seal

392 00 e-rb

Hinweise siehe erste Seite der Anlage, die Bestandteil des Prüfscheines ist.
For notes, see first page of the Annex which forms an integral part of the test certificate.

Physikalisch-Technische Bundesanstalt

Braunschweig und Berlin

**Prüfschein**

Test certificate

Ausgestellt für:

Issued to:

Sartorius AG
Weender Landstraße 94 – 108
37075 Göttingen
Bundesrepublik Deutschland

Prüfgrundlage:

In accordance with:

EN 45501 (1992), Nr. 8.1, WELMEC-Dokument 2.1 (Issue 2, 1998)
EWG Richtlinie 90/384/EWG, OIML R 76-1 (1992)

Gegenstand:

Object:

Lastaufnehmer mit Wägezelle und Auswerteelektronik mit digitalem Ausgang als Modul einer elektromechanischen Waage zum Anschluß an geeignete Anzeige- und Bedienterminals
Load receptor with load cell and electronic device with digital output as module of an electromechanical weighing instrument for connection to suitable display- and operator-terminals
Typ / type **HA BD**

Kennnummer:

Serial number:

Prüfscheinnummer:

*Test certificate number:*D09-95.18 1. Revision / *Revision 1*

Datum der Prüfung:

Date of Test:

Anzahl der Seiten:

Number of pages:

7

Geschäftszeichen:

Reference No.:

1.14 – 01035016

Benannte Stelle:

Notified Body:

0102

Im Auftrag

By order
Link

Braunschweig, 2001-05-21

Siegel

Seal

Plates and Markings

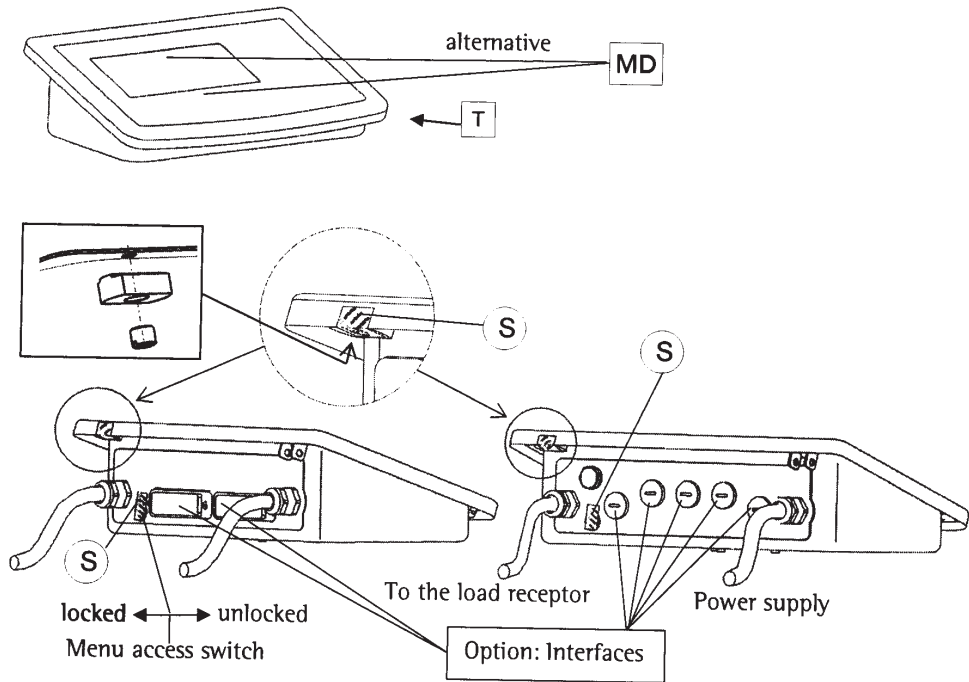

M Mark for EC verification
(green metrology sticker)

K Descriptive plate with CE-conformity mark

S Protective mark

MD Metrological data:
Max, Min, e, (d)

T Plate with model designation

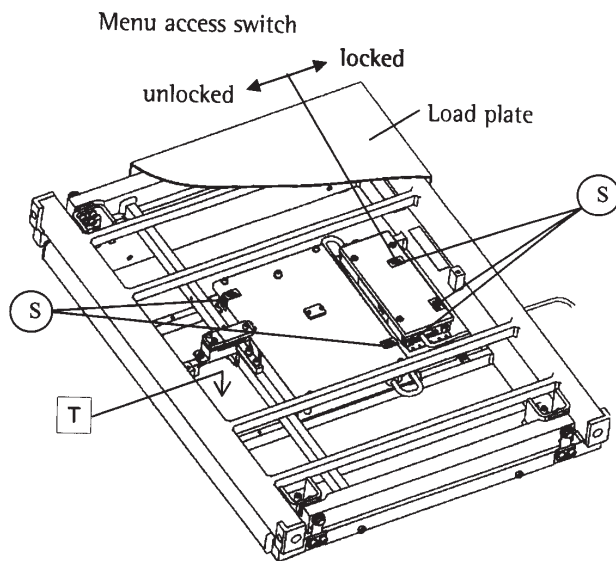

Type HC BF

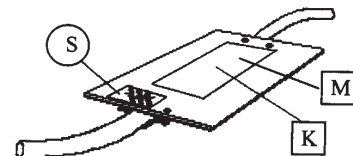

PPHC140308e

Type weighing instrument: iso-TEST Type weighing module: BF BF, HC BF, HA BD
EC type-approval certificate D97-09-018 + Test certificate D09-96.30, D09-95.18

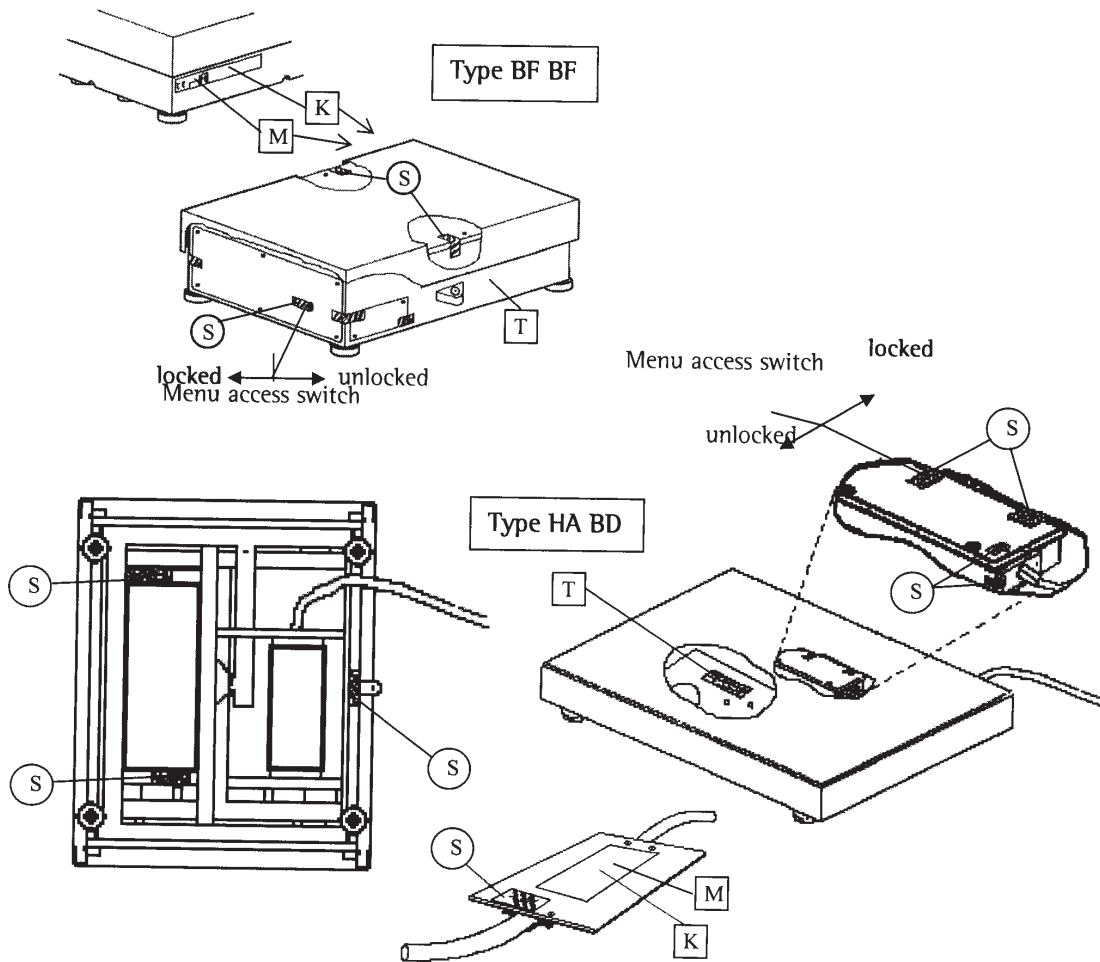

Example (type HC BF) of descriptive plate K on a weighing instrument already verified

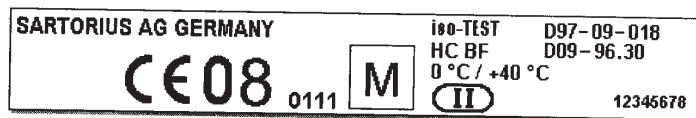

Example of plate with model designation (terminal) T



Example of plate with model designation (weighing module) T

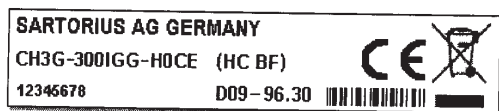

Index

	Page		Page
Access code	61	Net-total formulation	52
Accessories	102	Neutral measurement	31
Acoustic signal	16, 77	Operating design	10
Adjustment	25	Operating limits	9
Animal weighing	49	Operating menu overview	59
Applications, consultation	2	Operating menu parameters, overview	59
Automatic data output	86	Operation	15
Averaging	49	Password	61
Bar code scanner, connecting	85	Password, general	Appendix
Battery, external rechargeable, connecting	85	Peripherals, connecting	80
Cabling diagram	84	Pin assignment charts	81
Calibration/adjustment	25	Plates and markings	111
CE marking	107	Precautions	4
Checkweighing	35	Printer, configuring	72
Classification	40	Printing	89
Cleaning	95	Printout: samples	91
COM1 interface: settings	70	Printout: settings	76
Configuration	59	Recycling	95
Connecting cables to interfaces	83	Reference sample updating	28
Connecting the equipment to AC power	7	Repairs	95
Counting	27	Safety inspection	96
Data input format	86	Sample printouts	91
Data interfaces	79	SBI communication	85
Data output format	87	Scale drawings	101
Data output, configuring	89	Seal, verification	5
Data record: settings	70	Service	95
Data records: samples	91	Setting the time	78
Date and time, setting	78	Shipping conditions	5
Declaration of Conformity	107	Shutoff, automatic	16
Device information	78	Specifications	97
Device parameters	16, 68	Stainless steel surfaces, cleaning	95
Dimensions	99	Startup	5
Display elements	13	Storage and transport conditions	5
Display lighting	16, 77	Switch, remote (external)	76
EC type-approval certificate	109	Totalizing	55
Equipment supplied	5	Troubleshooting guide	94
General password	Appendix	Universal interface	73
General view of the equipment	6	Unpacking the equipment	5
Geographical data, checking	5	Warmup time	7
GMP-compliant printouts	77, 90	Warnings	4
ID codes	23	Weighing	15
Individual data ID codes	23	Weighing in percent	45
Installation instructions	5	Weighing platform WP1: settings	68
Installing the interface cable	83		
Intended use	2		
IP protection	4		
Key to model designations	98		
Keys, functions of	10, 14		
Language, setting	60, 78		
Legal metrology	5		
Leveling the weighing platform	9		
Maintenance	95		

General Password

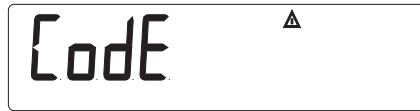

When you select "Setup", the password prompt is displayed for 2 seconds.



The first character of the password flashes.

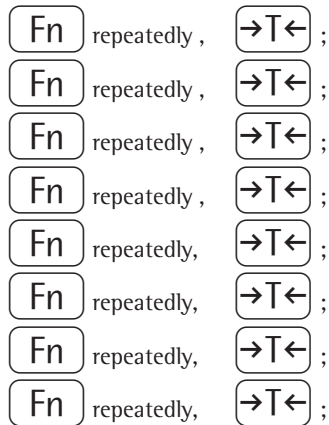

- Entering the password:
- Press **Fn** to select numbers and press **→** to confirm. Press either **Fn** (to scroll through numbers from 0 up to 9) or **←** (to scroll from 9 down to 0) repeatedly until the desired number is displayed.

The password is shown on the display.



Confirm the password entered.



Exit current menu level



Press and hold **→** (> 2 sec.)

Store input and exit the Setup menu



General password:
40414243

Service password:
202122

Sartorius AG
Weender Landstrasse 94-108
37075 Goettingen, Germany

Phone +49.551.308.0
Fax +49.551.308.3289
www.sartorius-mechatronics.com

Copyright by Sartorius AG,
Goettingen, Germany.
All rights reserved. No part
of this publication may
be reprinted or translated in
any form or by any means
without the prior written
permission of Sartorius AG.
The status of the information,
specifications and illustrations
in this manual is indicated
by the date given below.
Sartorius AG reserves the
right to make changes to
the technology, features,
specifications and design of
the equipment without notice.

Status:
August 2008, Sartorius AG,
Goettingen, Germany