

OPERATIONS MANUAL



MP2 SERIES
MODELS: MP2050E1,
MP2050E3, MP2090HP
MASONRY SAWS
(5 HP 1Ø ELECTRIC MOTOR)
(5 HP 3Ø ELECTRIC MOTOR)
(9.0 HP GASOLINE ENGINE)

Revision #1 (06/16/04)

**THIS MANUAL MUST ACCOMPANY
THE EQUIPMENT AT ALL TIMES.**



P/N: 35305



WARNING



CALIFORNIA — Proposition 65 Warning

Engine exhaust and some of its constituents, and some dust created by power sanding, sawing, grinding, drilling and other construction activities contains chemicals known to the State of California to cause cancer, birth defects and other reproductive harm. Some examples of these chemicals are:

- Lead from lead-based paints.
- Crystalline silica from bricks.
- Cement and other masonry products.
- Arsenic and chromium from chemically treated lumber.

Your risk from these exposures varies, depending on how often you do this type of work. To reduce your exposure to these chemicals: **ALWAYS** work in a well ventilated area, and work with approved safety equipment, such as dust masks that are specially designed to filter out microscopic particles.

HERE'S HOW TO GET HELP

PLEASE HAVE THE MODEL AND SERIAL
NUMBER *ON-HAND* WHEN CALLING

MULTIQUIP CORPORATE OFFICE

18910 Wilmington Ave.

Carson, CA 90746

Email: mq@multiquip.com

Internet: www.multiquip.com

800-421-1244

FAX: 310-537-3927

PARTS DEPARTMENT

800-427-1244

310-537-3700

FAX: 800-672-7877

FAX: 310-637-3284

MAYCO PARTS

800-306-2926

310-537-3700

FAX: 800-672-7877

FAX: 310-637-3284

SERVICE DEPARTMENT

800-478-1244

310-537-3700

FAX: 310-537-4259

TECHNICAL ASSISTANCE

800-478-1244

FAX: 310-631-5032

WARRANTY DEPARTMENT

800-421-1244, EXT. 279

310-537-3700, EXT. 279

FAX: 310-537-1173

© COPYRIGHT 2004, MULTIQUIP INC.

Multiquip Inc, the MQ logo and the Diamondback logo are registered trademarks of Multiquip Inc. and may not be used, reproduced, or altered without written permission. All other trademarks are the property of their respective owners and used with permission.

This manual MUST accompany the equipment at all times. This manual is considered a permanent part of the equipment and should remain with the unit if resold.

The information and specifications included in this publication were in effect at the time of approval for printing. Illustrations are based on the *MP2 Masonry Saw*. Multiquip Inc. reserves the right to discontinue or change specifications, design or the information published in this publication at any time without notice and without incurring any obligations.

To find the latest revision of this
publication, visit our website at:
www.multiquip.com



MP2 "MASON PRO" MASONRY SAW

Proposition 65 Warning	2
Here's How To Get Help	3
Table Of Contents	4
Parts Ordering Procedures	5
Specifications	6
Dimensions	7
Safety Message Alert Symbols	8-9
Rules For Safe Operation	10-12
Operation and Safety Decals	13
General Information	14
Controls and Components	16-17
Electric Motor Components	18
Engine Components	19
Pre-Setup (Electric)	20-22
Pre-Setup (Gasoline)	23-24
Startup/Shutdown (Electric Motors)	25
Startup/Shutdown (Gasoline Engines)	26-27
Maintenance (Saw)	29-31
Maintenance (Engines)	32-33
Honda Engine Wiring Diagram	34
Troubleshooting (Blade)	35
Troubleshooting (Gasoline Engine)	36-37
Troubleshooting (Electric Motor)	38
Terms and Conditions of Sale — Parts	40

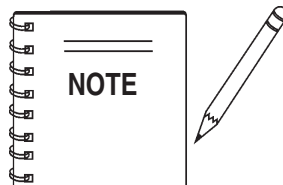

Specification and part number are subject to change without notice.

MP2 "MASON PRO" SAW — SPECIFICATIONS

TABLE 1. SAW SPECIFICATIONS

Saw Model	MP2050E1	MP2050E3	MP2090HP
Approximate Weight	415 lbs. (188 Kg.)		
Blade Capacity	20 in. blade maximum		
Cutting Depth	8 in. with 20 in. blade		
Blade Speed	2,240 RPM's		2,220 RPM's
Water Pump	115V/60Hz, Thermally protected		Mechanical/Centrifugal Water Pump

TABLE 2. ELECTRIC MOTOR/GAS ENGINE SPECIFICATIONS

Saw Model	MP2090HP	MP2050E1	MP2050E3
Engine/Motor	Honda GX270QWH2	5 H.P. Heavy Duty Electric 230V Single Phase 60 Hz Amps F.L. 12.0	5 H.P. Heavy Duty Electric 230V Three Phase 60 Hz Amps F.L. 12.0
Type	4-Stroke OHV Single Cylinder		
Bore & Stroke	3.0 x 2.3 in. (77 x 58 mm)		
Displacement	16.5 cu. in. (270 cc)		
Max Output	9.0 hp (6.7 KW) @ 3600 RPM		
Fuel Tank Cap.	1.59 U.S. Gal. (6.0 liters)		
Fuel	Unleaded Gasoline		
Lube Oil Cap.	1.16 U.S. Qt. (1.1 liters)		
Speed Control Method	Centrifugal Fly-Weight type		
Starting Method	Recoil Start		
Dimension	14.0 x 16.9 x 16.1 In. (355 x 430 x 410 mm)		
Dry Net Weight	55.1 Lbs. (25.0 Kg)		

MP2 "MASON PRO" SAW — DIMENSIONS

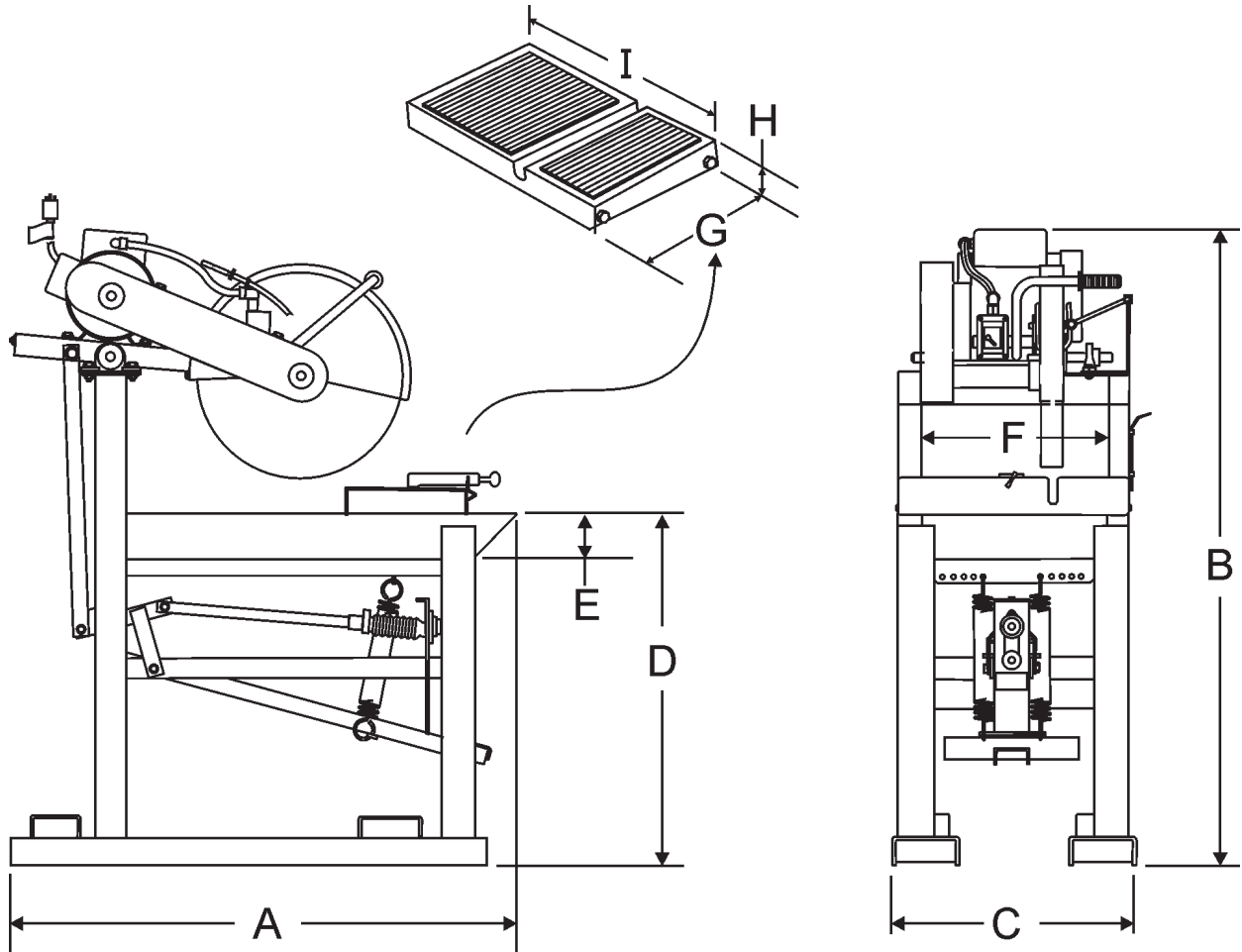

Figure 1. MP2 Dimensions

TABLE 3. DIMENSIONS		
REFERENCE LETTER	DESCRIPTION	DIMENSION (mm)
A	Max Length	48 In. (1219 mm)
B	Max Height (Electric Models)	61 In. (1549 mm)
	Max Height (Gasoline Models)	68 In. (1727 mm)
C	Max Width	23 In. (584 mm)
D	Tray Height	34.5 In. (876 mm)
E	Tray Depth	4.5 In. (114 mm)
F	Splash Shield Opening	18 In. (457 mm)
G	Cart Length	13.5 In. (343 mm)
H	Cart Height	2.5 In. (63.5 mm)
I	Cart Width	24 In. (610 mm)
WEIGHTS	MS 2090 HP	526 lbs. (239 Kg)
	MS 2050 E1	501 lbs. (227 Kg)
	MS 2050 E3	526 lbs. (239 Kg)

MP2 "MASON PRO" SAW — SAFETY MESSAGE ALERT SYMBOLS

FOR YOUR SAFETY AND THE SAFETY OF OTHERS!

Safety precautions should be followed at all times when operating this equipment. Failure to read and understand the Safety Messages and Operating Instructions could result in injury to yourself and others.

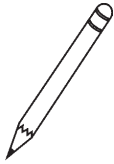

This Owner's Manual has been developed to provide complete instructions for the safe and efficient operation of the MP2 "Mason Pro" Saw.

For engine maintenance information, please refer to the engine manufacturers instructions for data relative to its safe operation.

Before using this MASONRY SAW, ensure that the operating individual has read and understands all instructions in this manual.

SAFETY MESSAGE ALERT SYMBOLS

The three (3) Safety Messages shown below will inform you about potential hazards that could injure you or others. The Safety Messages specifically address the level of exposure to the operator, and are preceded by one of three words: **DANGER**, **WARNING**, or **CAUTION**.

DANGER

You **WILL** be **KILLED** or **SERIOUSLY** injured if you **DO NOT** follow directions.

WARNING

You **CAN** be **KILLED** or **SERIOUSLY** injured if you **DO NOT** follow directions.

CAUTION

You **CAN** be injured if you **DO NOT** follow directions.

HAZARD SYMBOLS

Potential hazards associated with operation of the pump will be referenced with Hazard Symbols which appear throughout this manual, and will be referenced in conjunction with Safety Message Alert Symbols. Some examples are listed below:

WARNING - Guards and Covers In Place

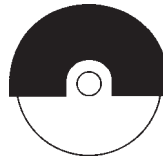

NEVER operate the saw without blade guards and covers in place. Adhere to safety guidelines ANSI American National Standards Institute, OSHA or other applicable local regulations.

WARNING - Rotating Blade



Rotating blade can cut and crush. Keep hands and feet clear.

WARNING - Burn Hazards



Engine components can generate extreme heat. To prevent burns, **DO NOT** touch these areas while the engine is running or immediately after operations. **NEVER** operate the engine with heat shields or heat guards removed.

WARNING - Rotating Parts



NEVER operate equipment with covers, or guards removed. Keep fingers, **hands**, **hair** and **clothing** away from all moving parts to prevent injury.

MP2 "MASON PRO" SAW — SAFETY MESSAGE ALERT SYMBOLS

WARNING - Accidental Engine Starting



ALWAYS place the engine **ON/ OFF** switch in the **OFF** position, when the saw is not in use.

WARNING - Over Speed Conditions



NEVER tamper with the factory settings of the engine governor or settings. Personal injury and damage to the engine or equipment can result if operating in speed ranges above maximum allowable.

CAUTION - Respiratory Hazard



ALWAYS wear approved respiratory protection that complies with ANSI-Z87.1.

CAUTION - Sight and Hearing Hazards

ALWAYS wear approved eye and hearing protection that complies with ANSI-Z87.1

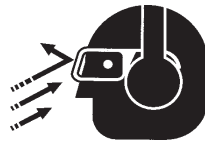

CAUTION - Equipment Damage Messages

Other important messages are provided throughout this manual to help prevent damage to your concrete saw, other property, or the surrounding environment.

HAZARD SYMBOLS - Gasoline Powered Models

WARNING - Lethal Exhaust Gases



Engine exhaust gases contain poisonous carbon monoxide. This gas is colorless and odorless, and can cause death if inhaled. **NEVER** operate this equipment in a confined area or enclosed structure that does not provide ample free flow air.

WARNING - Explosive Fuel



Gasoline is extremely flammable, and its vapors can cause an explosion if ignited. **DO NOT** start the engine near spilled fuel or combustible fluids. **DO NOT** fill the fuel tank while the engine is running or hot.

DO NOT overfill tank, since spilled fuel could ignite if it comes into contact with hot engine parts or sparks from the ignition system. Store fuel in approved containers, in well-ventilated areas and away from sparks and flames. **NEVER** use fuel as a cleaning agent.

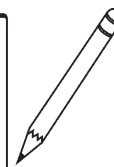
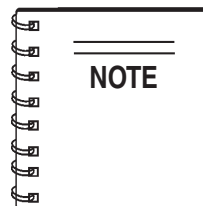

This **saw**, other property, or the surrounding environment could be damaged if you do not follow instructions.

MP2 "MASON PRO" SAW — RULES FOR SAFE OPERATION

WARNING - READ THIS MANUAL

Failure to follow instructions in this manual may lead to serious injury or even death! This equipment is to be operated by trained and qualified personnel only! This equipment is for industrial use only.

The following safety guidelines should always be used when operating the MP2 "Mason Pro" Saw. Unless otherwise noted, these guidelines refer to saws with gasoline powered engines.

Safety

■ **DO NOT** operate or service this equipment before reading this entire manual.



■ This equipment should not be operated by persons under 18 years of age.

■ **NEVER** operate the saw without proper protective clothing, shatterproof glasses, steel-toed boots and other protective devices required by the job.



■ **NEVER** operate this equipment when not feeling well due to fatigue, illness or taking medicine.



■ **NEVER** operate the saw under the influence of drugs or alcohol.



■ **NEVER** use accessories or attachments, which are not recommended by Multiquip for this equipment. Damage to the equipment and/or injury to user may result.

■ Manufacturer does not assume responsibility for any accident due to equipment modifications. Unauthorized equipment modification will void all warranties.

■ Whenever necessary, replace nameplate, operation and safety decals when they become difficult read.

■ **ALWAYS** check the saw for loosened threads or bolts before starting.

■ **NEVER** operate the saw in an explosive atmosphere where fumes are present or near combustible materials. An explosion or fire could result causing severe **bodily harm or even death**.

■ **NEVER** use fuel as a cleaning agent.

Safety - Gasoline Powered Engines

■ **NEVER** touch the hot exhaust manifold, muffler or cylinder. Allow these parts to cool before servicing the saw.

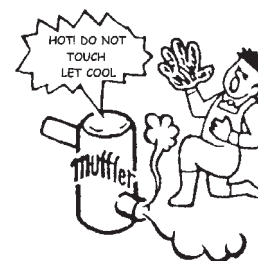

■ **High Temperatures** – Allow the engine to cool before adding fuel or performing service and maintenance functions. Contact with **hot!** components can cause serious burns.

■ The engine of this saw (**gasoline model only**) requires an adequate free flow of cooling air. **NEVER** operate the saw in any enclosed or narrow area where free flow of the air is restricted. If the air flow is restricted it will cause serious damage to the saw's engine and may cause injury to people. Remember the saw's engine gives off **DEADLY** carbon monoxide gas.

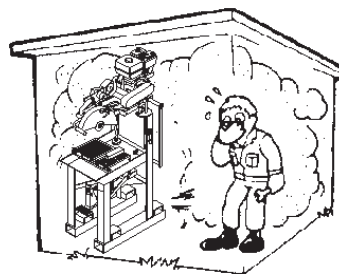

■ **ALWAYS** stop the engine before servicing, adding fuel and oil.

■ **ALWAYS** refuel in a well-ventilated area, away from sparks and open flames.

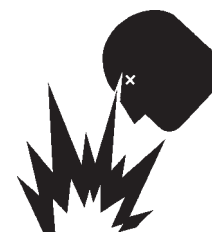

■ **ALWAYS** use extreme caution when working with **flammable** liquids. When refueling, **stop the engine** and allow it to cool.

■ **NEVER** smoke around or near the machine. Fire or explosion could result from **fuel vapors**, or if fuel is spilled on a **hot!** engine.



■ Topping-off to filler port is dangerous, as it tends to spill fuel.

■ **ALWAYS** service air cleaner frequently to prevent carburetor malfunction.

■ **NEVER** run the engine without the air filter. Severe engine damage could occur. (Gasoline powered engines)

MP2 "MASON PRO" SAW — RULES FOR SAFE OPERATION

Safety - Electric Powered Models

- **ALWAYS** connect the motor to a power source in compliance with all local electrical codes. This must be performed by a **licensed electrician**.
- **ALWAYS** use only outdoor approved **GROUND**ED extension cords.
- **MAKE CERTAIN** the power cord/extension cord is free from damage and that the grounding circuit is operational.
- **MAKE CERTAIN** the extension cord used is intended to be used in the environment you will be using it in. If an extension is used, **NEVER** submerge the connection in water. To reduce the risk of electrical shock, always make water-tight connections.
- **MAKE CERTAIN** the "ON/OFF" switch is in the "OFF" position before plugging in the power cord/extension cord to avoid accidental starting.
- **ALWAYS** stop the motor before servicing. **MAKE CERTAIN** the motor is stopped and turned "OFF" at the switch, and the power cord is disconnected from the power source.
- Use only the gauge wire and length of cord recommended for the motor size.
- When cutting, **ALWAYS** be aware of the location of the cord.

General Safety

- **ALWAYS** read, understand, and follow procedures in Operator's Manual before attempting to operate equipment.
- **ALWAYS** be sure the operator is familiar with proper safety precautions and operating techniques before using the saw.
- **NEVER** leave the machine **unattended** while running.
- Block the unit when leaving or when using on a slope.
- **ALWAYS** check to make sure that the operating area is clear before starting the engine.
- Maintain this equipment in a safe operating condition at all times.
- **AVOID** wearing jewelry or loose fitting clothing that may snag on the controls or moving parts, this can cause a serious injury.

- **ALWAYS** keep clear of **rotating** or **moving parts** while operating the saw.
- **ALWAYS** store equipment properly when it is not being used. Equipment should be stored in a clean, dry location out of the reach of children.
- **NEVER** use accessories or attachments which are not recommended by the manufacturer for this equipment. Damage to the equipment and/or injury to user may result.

 **WARNING - Clear Area Of Obstructions**

 **ALWAYS** check to make sure that the operating area is clear before starting the engine.

Blade Safety

- Use appropriate blades manufactured for use on masonry saws.
- Always inspect blades before each use. The blade should exhibit no cracks, dings, or flaws in the steel centered core and/or rim. Center (arbor) hole must be undamaged and true.
- Examine blade flanges for damage, excessive wear and cleanliness before mounting blade. Blade should fit snugly on the shaft and against the inside/outside blade flanges.
- Ensure the blade is marked with an operating speed greater than the blade shaft speed of the saw.
- Only cut the material that is specified by the blade. Read the specifications of the blade to ensure the proper tool has been matched to the material being cut.
- Always keep blade guards in place. Exposure of the blade must not exceed 180 degrees.
- **NEVER** touch or try to stop a moving blade with your hands. **ALWAYS** keep hands clear of the blade.



MP2 "MASON PRO" SAW — RULES FOR SAFE OPERATION

- Ensure that the blade does not come into contact with the ground or surface during transportation. **DO NOT** drop the blade on ground or surface.
- The engine governor is designed to permit maximum engine speed in a no-load condition. Speeds that exceed this limit may cause the blade to exceed the maximum safe allowable speed.
- Ensure that the blade is mounted for proper operating direction.

Saw Maintenance (Cleaning)

- **ALWAYS** clean the saw before maintenance or repair.
- **DO NOT** use aggressive cleaners (i.e. containing solvents). **DO NOT** use high pressure water jets, aggressive detergents or solutions and liquids with a temperature exceeding 86 F. Use a fluff-free cloth only.
- Use a cloth which may be lightly moistened only for removing dust and dirt. Hard packed dirt can be removed with a **soft** brush.
- **NEVER** let water, cleaning liquid or vapor penetrate into the electric motor, connectors, plugs, and switches. When cleaning cover all apertures or openings on all electrical components.
- **ALWAYS** use a soft, low-pressure water jet and a brush to rinse dirt and incrustations away. Be particularly careful not to spray water on sensitive parts of the saw (e.g. electric motor, ON/OFF switch). Clean the motor and ON/OFF switch by wiping with a **moist** cloth.
- **DO NOT** rinse the bearings of the drive elements (gasoline model only).

Saw Transportation Safety

- Use an appropriate lifting equipment to ensure the safe movement of the saw.
- **DO NOT** use the handles as lifting points.
- Safeguard against extreme saw attitudes relative to level. An engine tipped to extreme angles may cause oil to gravitate into the cylinder head making the engine start difficult. (Gasoline powered engines)
- **NEVER** transport the saw with the blade mounted.

Emergencies

- **ALWAYS** know the location of the nearest **fire extinguisher**.



- **ALWAYS** know the location of the nearest and **first aid kit**.



- In emergencies **always** know the location of the nearest phone or **keep a phone on the job site**. Also know the phone numbers of the nearest **ambulance, doctor and fire department**. This information will be invaluable in the case of an emergency.



MP2 "MASON PRO" SAW — OPERATION AND SAFETY DECALS

Machine Operation And Safety Decals

The MP2 "Mason Pro" Saw is equipped with a number of safety decals (Figure 2). These decals are provided for operator safety and maintenance information. Should any of these decals become unreadable, replacements can be obtained from your dealer.

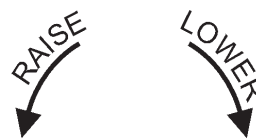
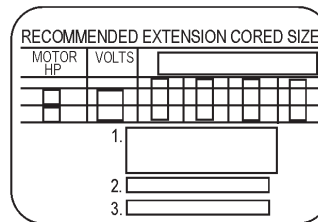
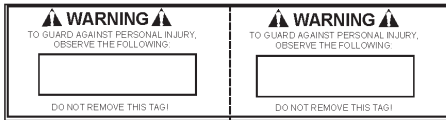
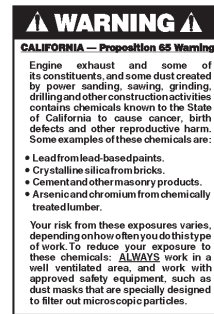

Figure 2. MP2 Decals

MP2 "MASON PRO" SAW — GENERAL INFORMATION

MP2 "Mason Pro" Saw

The MP2 "Mason Pro" Saw is designed for vigorous wet-cutting masonry applications. The heavy-duty steel conveyor cart and ball bearing roller wheels ensure material stability and smooth travel. In addition a reinforced jig-welded steel frame provides rigidity for cutting accuracy and long service life.

This saw is available with either an **electric motor** or a **gasoline engine**. Two heavy duty electric motors are available: a 5 HP 230V single phase or 5 HP 230V three phase, all with overload protection.

If desired, the MP2 "Mason Pro" Saw can be configured with a 9.0 HP Honda GX270 gasoline engine.

All MP2 saw models include a high flow water pump, cutting jig, water hoses and associated plumbing to enable the operator to begin wet cutting.

Dry Cutting Applications

The MP2 "Mason Pro" Saw masonry saw is shipped from the factory for wet-cutting saw applications, however it can be used for **dry-cutting saw** applications (see dry-cutting saw applications in this manual). The most important thing to remember is to **disconnect the water pump**. The water pump is cooled by the flow of water, and failure to disconnect the pump (when running dry) will cause pump failure. **NEVER!** have the water pump engaged when dry cutting applications are involved.

Blade Applications

This saw has been designed to incorporate the use of diamond blades as the cutting tool. The optimum performance of this saw is best evidenced by using 20-inch (508 mm) diamond blades that match the material being cut. Ask your dealer, or call **Multiquip** about your specific cutting application.

Overview of Features

- 5 HP, 230 VAC, 60 Hz heavy duty electric motors with overload protection.
- 9 HP Honda GX270 gasoline engine.
- 20-inch blade capacity provides 5-inch depth of cut.
- Rugged steel conveyor cart for optimum stability.
- Open back design permits capability of cutting large materials.
- Ergonomically designed cutting head provides operator relief in high tempo operations.
- Welded fork pockets for easy transportation.
- Rubber-matted cutting table helps hold the material being cut in place while resisting vibrations for smoother cuts with less chipping.
- Cutting table marked in inches (ruler) for precision cuts.
- Stay-level blade guard for operator safety.
- Rigid steel frame minimizes vibrations and assures accurate cutting.
- Mechanical Water Pump Kit (Gasoline Model Only)
- Electric Submersible Water Pump Kit (Electric Models Only).

MP2 "MASON PRO" SAW — CONTROLS AND COMPONENTS

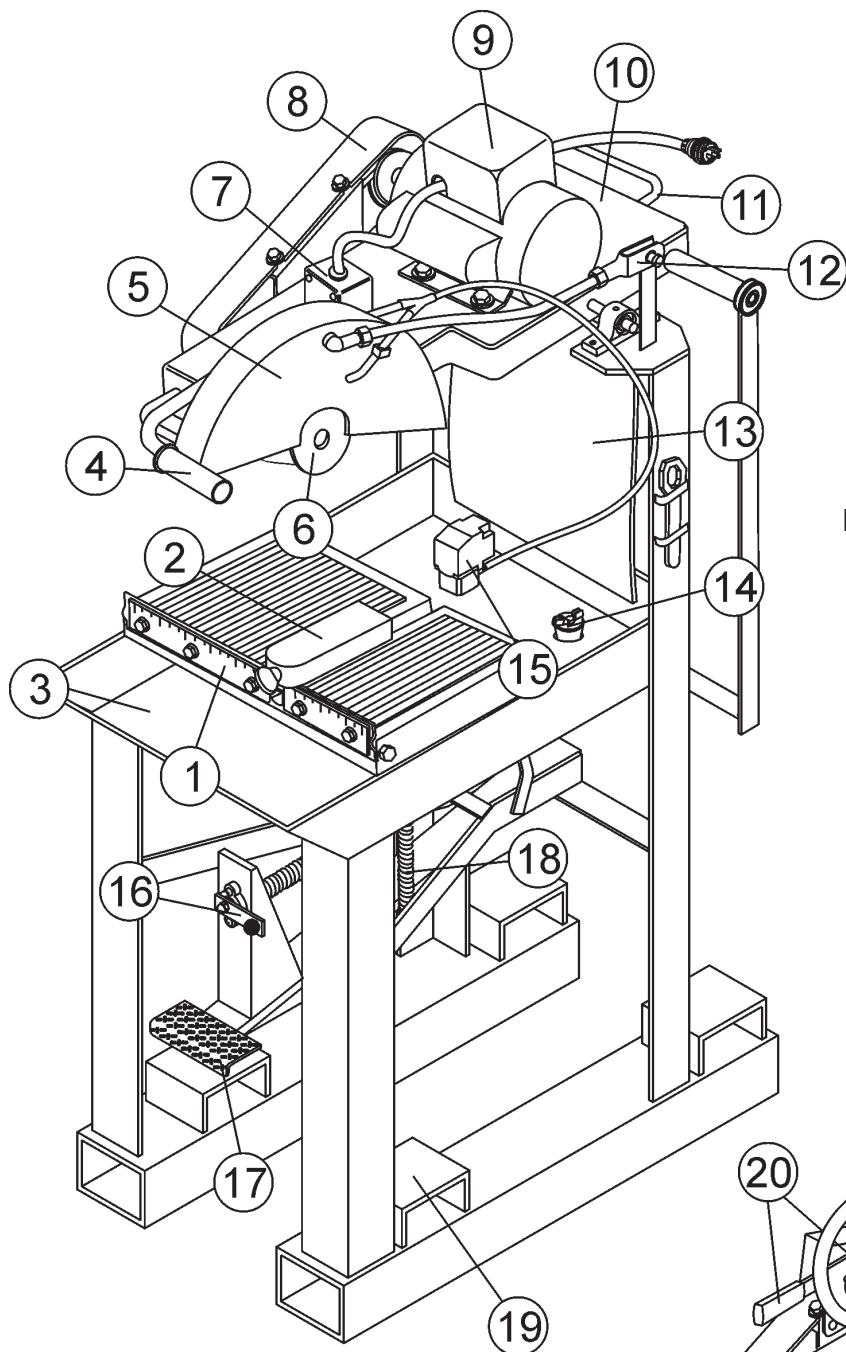

Figure 3. MP2 Saw (Electric Models)

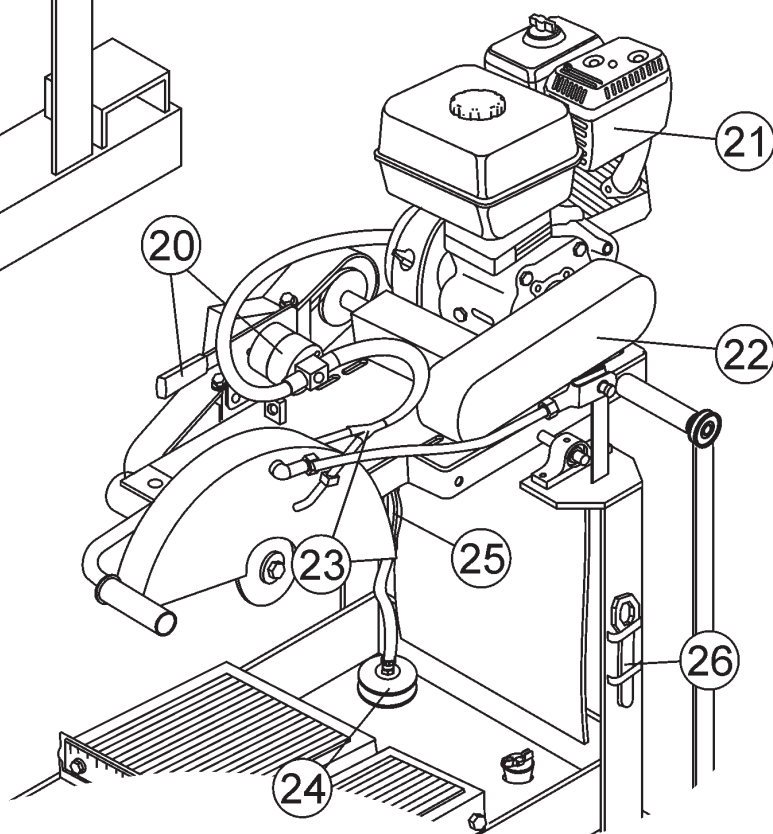

Figure 3. MP2 Saw (Gasoline Models)

MP2 "MASON PRO" SAW — CONTROLS AND COMPONENTS

Figure 3 shows the location of the basic controls or components for the MP2 "Mason Pro" Saw. Listed below is a brief explanation of each control or component.

1. **Ruler Backstop** – When cutting, place material against backstop. Use measurement rail (ruler) to determine where material is to be cut.
2. **Miter Box** – For angled cuts, place the lip of the miter box on the measurement rail with the threaded thumb knob facing you and tighten.
3. **Water Tray** – When wet cutting is required, fill with clean fresh water. Make sure the water pump is totally immersed in water before cutting.
4. **Cutting Head Handle** – Grab hold of this handle to control the movement of the cutting head as you step on the Blade Raise/Lower Foot Pedal.
5. **Blade Guard** – Protects the user from the cutting blade. **NEVER** operate the saw with the blade guard removed.
6. **Spindle Bolt/Outside Blade Flange** – When mounting of the cutting blade is required, remove the spindle bolt and outside blade flange. Align cutting blade with inside flange arbor and reassemble spindle and outside blade flange.
7. **Power ON/OFF Box** – This box is used on **electric models saws only**. To turn on the saw place in the **ON (I)** position. Place in the **OFF (0)** position to shut-down the saw.
8. **V-belt Cover** – Remove this cover to access the drive V-belt. **NEVER** operate the saw with the V-belt cover removed.
9. **Electric Motor/Conduit Box** – This unit uses 2 different types of electric motors and voltages (see Table 2). Plug the water pump (electric models only) power cord into the AC receptacle located on the conduit box.
10. **Mounting Plate** – Supports the electric motor/gasoline engine. Plate has slotted holes for horizontal (right-side) and vertical (left-side) adjustment of cutting head.
11. **Mounting Plate Handle** – Grip this handle (rear) to lift the mounting plate.
12. **Tie Rod** – The tie rod length has been set at the factory for best blade guard position for the majority of the cutting that will be done.
13. **Splash Guard** – Keeps water and debris from leaving the water tray.
14. **Stopper** – Place stopper in tray when filling with water.
15. **Electric Water Pump** – For best results place the pump between the splash shield and the rear of the water tray. This is for electric models only. Plug water pump power cord into AC receptacle on electric motor conduit box. **NEVER** run pump dry. Pump must be immersed in water.
16. **Blade Raise/Lower Crank Handle** – Use this handle to set the maximum cutting depth of the MP2 "Mason Pro" Saw. Turn **clock-wise** to **LOWER** the blade. Turn **counter-clock-wise** to **RAISE** the blade.
17. **Blade Raise/Lower Foot Pedal** – Step on the pedal to lower the blade for cutting. Gently step off the pedal to raise the blade when finished cutting.
18. **Spring Tensioner** – Connects to the foot pedal bar to allow for an easy up and down movement of the mounting plate and blade.
19. **Forklift Pockets** – Use to easily move the MP2 "Mason Pro" Saw from one location to another. When moving the saw, ensure that the forks pass completely through the pockets on both sides of the machine before attempting to lift the MP2.
20. **Mechanical Water Pump** – This pump is used on gasoline models only. Saw is shipped from the factory for wet cutting applications (pump handle down). Place pump handle upwards to disengage pump. **NEVER** run pump dry.
21. **Engine** – The gasoline model saws uses a 9.0 HP Honda GX270, 4-stroke, OHV, single cylinder, air cooled gasoline engine.
22. **V-belt Cover (Gasoline Only)** – Remove this cover to access the engine shaft-side V-belt. **NEVER** operate the saw with the V-belt cover removed.
23. **Water Lines** – Replace the clear vinyl tubing water lines when they become brittle, worn or clogged. Water kits are available through your dealer.
24. **Strainer** – For best results place the strainer between the splash shield and the rear of the water tray. This is for gasoline models only. **NEVER** run pump dry. Strainer must be immersed in water.
25. **Priming Bulb** – Squeeze this bulb to prime the mechanical water pump (gasoline models only).
26. **Blade Wrench** – Use this tool to mount and remove cutting blade.

MP2 "MASON PRO" SAW — ELECTRIC MOTOR COMPONENTS

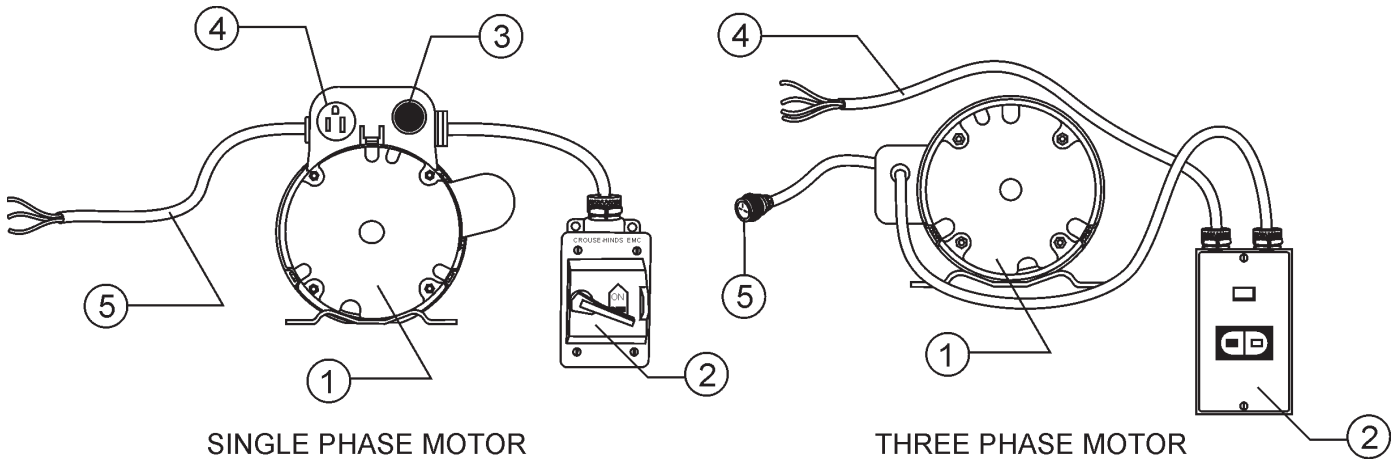

Figure 4. Electric Motor Components

Heavy Duty Electric Motors

The MP2 Saw can be equipped with several different models of electric motors. Figure 4 shows the basic components of the electric motor. Refer to the manufacturer's electric motor manual for instructions & details of operation and servicing.

1. **Electric Motor** – The MP2 saw can be operated with either a Single Phase or Three Phase 230V motor. Only qualified electricians should service the motor.
2. **Power ON/OFF Box** – To turn on the saw, place switch in the **ON** position. Place in the **OFF** position to shutdown the saw.
3. **Electric Motor Reset Switch** – This switch is part of the thermal overload protection for the electric motor. If the motor overheats and shuts down, press this switch to reset the motor, after allowing the motor to cool down. This is used on **Single phase** electric saws only.
4. **Water Pump AC Power Receptacle** – Plug the electric water pump into this receptacle to provide power to the pump during saw operation. Unplug the electric water pump from this receptacle when dry cutting.
5. **Electric Motor Wiring Pigtail** – The saw motor ships with cable "pigtail." Have a licensed electrician supply and install the appropriate NEMA connector.

! WARNING - Wiring Three Phase Motors

All saws equipped with **three phase motors** should be wired by a qualified electrician and correct motor rotation verified before operating the saw.

! DANGER - Electrocutation Hazard

NEVER grab or touch a live power cord with wet hands, the possibility exists of electrical shock, electrocution, and even **death!**

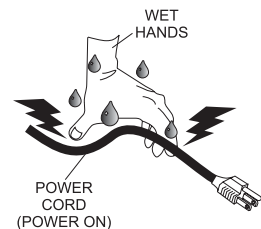

NEVER use a **damaged** or **worn** extension cable when connecting to a power source. Defective cables may cause damage to the saw's electric motor or electrical shock.

MP2 "MASON PRO" SAW — GASOLINE ENGINE COMPONENTS

Honda GX270QWH2 Gasoline Engine

The engine (Figure 5) must be checked for proper lubrication and filled with fuel prior to operation. Refer to the manufacturer's engine manual for instructions & details of operation and servicing.

1. **Fuel Tank/Fuel Filler Cap** – Holds unleaded gasoline. For additional information refer to engine owner's manual. Remove this cap to add unleaded gasoline to the fuel tank. Make sure cap is tightened securely. **DO NOT** over fill.

DANGER - Explosive Fuel Hazard



Adding fuel to the tank should be done only when the engine is stopped and has had an opportunity to cool down. In the event of a fuel spill, **DO NOT** attempt to start the engine until the fuel residue has been completely wiped up, and the area surrounding the engine is dry.

2. **Throttle Lever** – Used to adjust engine RPM speed (lever advanced forward **SLOW**, lever back toward operator **FAST**).
3. **Engine ON/OFF Switch** – **ON** position permits engine starting, **OFF** position stops engine operations.
4. **Recoil Starter (pull rope)** – Manual-starting method. Pull the starter grip until resistance is felt, then pull briskly and smoothly.
5. **Fuel Valve Lever** – **OPEN** to let fuel flow, **CLOSE** to stop the flow of fuel.
6. **Choke Lever** – Used in the starting of a cold engine, or in cold weather conditions. The choke enriches the fuel mixture.
7. **Air Cleaner** – Prevents dirt and other debris from entering the fuel system. Remove wing-nut on top of air filter cannister to gain access to filter element.

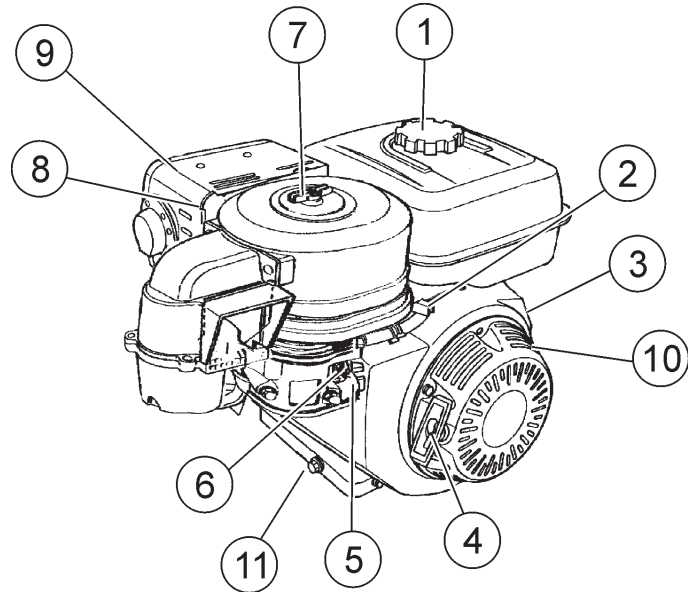
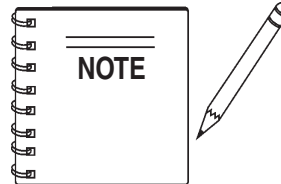

Figure 5. Engine Controls and Components



Operating the engine without an air filter, with a damaged air filter, or a filter in need of replacement will allow dirt to enter the engine, causing rapid engine wear.

8. **Spark Plug** – Provides spark to the ignition system. Set spark plug gap to 0.6 - 0.7 mm (0.028 - 0.031 inch) Clean spark plug once a month.
9. **Muffler** – Used to reduce noise and emissions

DANGER - Burn Hazard



Engine components can generate extreme heat. To prevent burns, **DO NOT** touch these areas while the engine is running or immediately after operating. **NEVER** operate the engine with the muffler removed.

10. **Oil Level Cap and Dipstick** – Check engine oil with engine stopped and in a level position.
11. **Oil Drain Bolt** – Drain used oil while the engine is warm.

MP2 "MASON PRO" SAW — PRE-SETUP (ELECTRIC MOTORS)

Pre-Setup

WARNING - Shut-down Saw for Cleaning

Whenever cleaning, adjusting or lubricating any part of the saw, **MAKE CERTAIN** to place the power **ON/OFF** switch in the **OFF** position and disconnect the plug from the power source.

Assembly (Electric Powered Saws Only)

1. Remove the MP2 "Mason Pro" Saw from its container and place it on a stable, level surface. Make sure location you choose can support the weight of the saw. The saw location should be rigid and stationary so that the saw will not move, sag, or sway due to the vibrations and movements of the saw.
2. Connect the barb fitting to the water pump. Attach the clear plastic water hose (Figure 6) coming from the blade guard to the water pump.
3. Fill the water tray with **clean fresh water**. The **water pump intake must always be fully covered by water**. Also, keep the pump intake free of sludge, debris and other materials that may accumulate in the tray.
4. Make certain that the water hose will not come in contact with the blade or interfere with any moving parts. The best location for the water pump/strainer is between the splash shield and the rear of the water tray. This will prevent some of the abrasive particles from flowing through the pump.

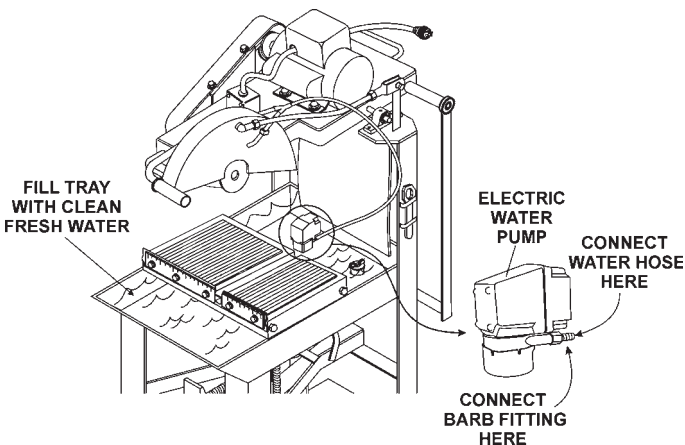

Figure 6. Water Tray/Water Pump

5. Insert the water pump **power plug** into the outlet receptacle on the electric motor conduit box as shown in Figure 7.

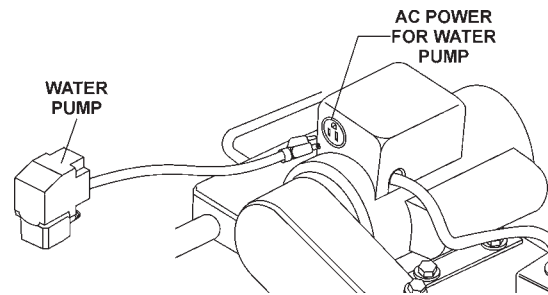

Figure 7. Water Pump Power Connection

For three-phase motors, you may be required to install a plug on the end of the water pump power cable, which should have 3 wires exposed. Have a qualified electrician install a male plug that has been properly rated for the equipment(230V).

Once a plug has been installed, insert the power plug into the receptacle plug cord attached to the motor. (Electric Motor Components, item 3)

Conveyor Cart Placement

1. Place the conveyor cart across the water tray as shown in Figure 8. Align the wheels of the cart with the outer edge of the water tray. Push the cart back and forth, it should move freely in both directions.

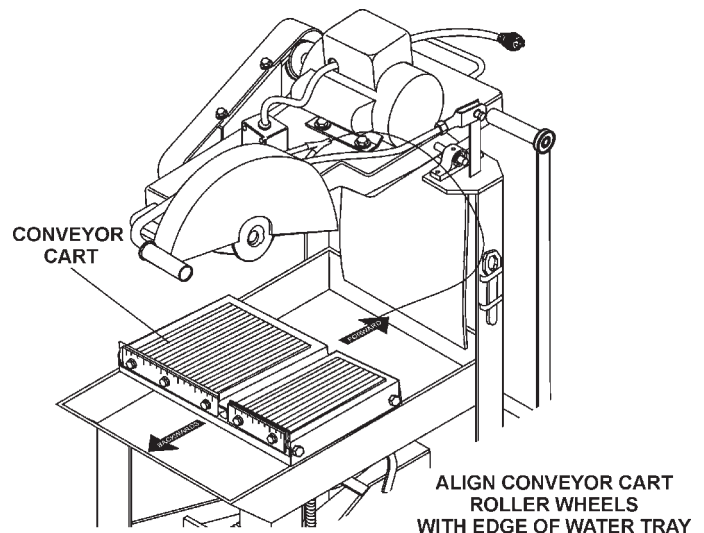

Figure 8. Conveyor Cart Placement

MP2 "MASON PRO" SAW — PRE-SETUP (ELECTRIC MOTORS)

WARNING - Inspect the Blade before Cutting



Failure to thoroughly inspect the blade for operational safety could result in damage to the blades or the saw and may cause serious injury to the user or others in the operating area. Inspect the blade flanges and shaft for damage before installing the blade.

Saw Blades

Diamondback Diamond Blades™ are recommended for your saw. Ask your MQ dealer about your specific cutting application.

Saw Blade Definitions (Figure 9)

1. **Stress Relief Holes (Gullets)** - Check the steel core for cracks that may have propagated from the slots and/or gullets. Cracks indicate extreme fatigue failure and if sawing continues, catastrophic failure will occur.

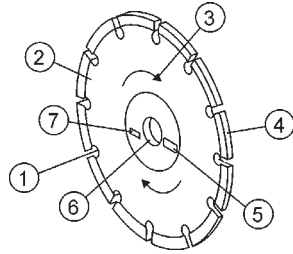

Figure 9. Diamond Blade

2. **Edge of the Steel Core** - Check the diameter edge for discoloration (blue oxidation) indicating an overheating condition caused by insufficient cooling water/air. Overheating of blades may lead to loss of core tension and/or increase the possibility for blade failure. Make sure the steel core's width is uniform about the rim of the blade, and not succumbing to an "under-cutting" condition brought about by highly abrasive material or improper under-cutting core protection.
3. **Directional Arrow** - Ensure that the blade is oriented properly on the blade shaft for sawing. Reference the directional arrow on the blade and place it so the direction of rotation "downcuts" with the turn of the shaft.
4. **Diamond Segment or Rim** - Ensure there are no cracks, dings, or missing portions of the diamond segment/rim. **DO NOT use a blade that is missing a segment or a portion of the rim.** Damaged and/or missing segments/rims may cause damage to your saw or injury to the user or others in the operating area.

5. **Specifications** - Ensure that the blade specifications, size, and diameter properly match up to sawing operations. Utilizing a blade not matched properly to the task may result in poor performance and/or blade damage.
6. **Arbor Hole** - It is essential that the arbor hole diameter properly matches the blade, and that it is free from distortion. Correct blade flanges (collars) must be used. The inside face of the flanges must be clean and free of debris. An out-of-round arbor condition will cause damage to the blade and the saw.
7. **Max RPM** - This RPM reference is the maximum safe operating speed for the blade selected. **NEVER** exceed the max RPM on the diamond blade. Exceeding the maximum RPM is dangerous and may cause poor performance and may damage the blade.

Blade Installation

1. Use the **blade bolt wrench** (Figure 10) supplied with the saw to install the cutting blade.
2. Ensure the capacity of the blade guard matches the diameter of your cutting blade.
3. Using the blade nut wrench, remove the **blade shaft bolt** and **outside blade flange**. Install the cutting blade onto the **inside blade flange arbor**. Re-install the outside blade flange and blade shaft bolt. Tighten securely. **DO NOT** over tighten.

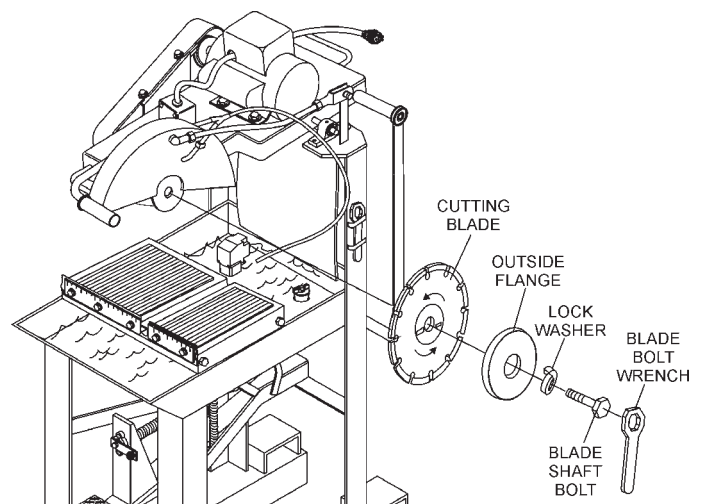
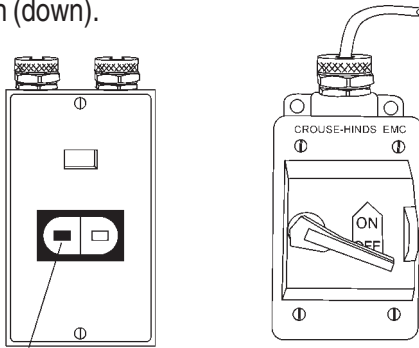

Figure 10. Blade Placement

MP2 "MASON PRO" SAW — PRE-SETUP (ELECTRIC MOTORS)

Connecting the Power (Figure 10)

1. Place the power **ON/OFF** switch (Figure 11) in the **OFF** position (down).



PUSH TO TURN OFF

Figure 11. Power ON/OFF Switch (OFF)

2. Connect an extension cord (Figure 13) of adequate current carrying capacity to the power plug on the electric motor.

! DANGER - Electrocutation Hazard

NEVER grab or touch a live power cord with wet hands, the possibility exists of electrical shock, electrocution, and even **death!**

NEVER use a **damaged** or **worn** extension cable when connecting to a power source. Defective cables may cause damage to the saw's electric motor or electrical shock.

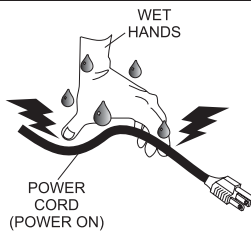

! CAUTION - Dry Cutting & Water Pump

MAKE CERTAIN that the correct size extension cord is used. Undersize wires will burn out motors. Use Table 4 to determine the correct extension cord size.

TABLE 4. EXTENSION CORD SIZES

MOTOR	VOLTAGE	50' LONG	75' LONG	100' LONG
5HP - SINGLE PHASE	230	No. 10	No. 8	No. 6
5HP - 3 PHASE	230	No. 12	No. 10	No. 8
5HP - 3 PHASE	460	No. 14	No. 12	No. 10
7.5HP - 3 PHASE	230	No. 10	No. 8	No. 6
7.5HP - 3 PHASE	460	No. 12	No. 10	No. 8

! CAUTION - Grounding Electric Motors

ALWAYS use a **grounded (3-wire)** extension cord and **MAKE CERTAIN** that the motor is connected to a properly grounded electric circuit. If possible use a ground fault circuit interrupter to protect the operator from possible **electric shock**.

4. The MP2 "Mason Pro" Saw is now ready for **wet cutting**.

Dry Cutting (Electric Saws Only)

1. Un-plug the water pump power cord from the outlet receptacle on the electric motor conduit box.

! CAUTION - Dry Cutting & Water Pump

NEVER dry cut with the pump connected to a AC power source. Running the pump **dry** will **damage** the pump. Always disconnect the pump's power cord when dry cutting.

2. The MP2 Masonry Saw is now ready for **dry cutting**.

MP2 "MASON PRO" SAW — PRE-SETUP (GASOLINE ENGINE)

Pre-Setup

CAUTION - Shut-down Saw for Cleaning

Whenever cleaning, adjusting or lubricating any part of the saw, **MAKE CERTAIN** to stop the engine and disconnect the spark plug wire from the spark plug.

The MP2 "Mason Pro" Saw gasoline model utilizes some of the same procedures that are used for the electric models. Please reference pages 20 and 21 for the below referenced procedures:

- Conveyor Cart Placement
- Blade Selection and Inspection
- Saw Blades
- Blade Installation

Assembly (Gasoline Powered Saws Only)

1. Remove the saw from its container and place it on a stable, level surface. Make sure location you choose can support the weight of the saw. The saw location should be rigid and stationary so that the saw will not move, sag, or sway due to the vibrations and movements of the saw.
2. The **gasoline powered** saw uses a **mechanical water pump**. This pump operates by drawing power from the drive V-belts, and has been adjusted **dry cutting** operation when shipped from the factory.
3. Fill the water tray with clean fresh water. The **water pump intake (strainer) must always be fully covered by water to operate effectively**. Also, keep the pump intake free of sludge, debris and other materials that may accumulate in the tray.
4. Make certain that the water hose will not come in contact with the blade or interfere with any moving parts. The best location for the water pump/strainer is between the splash shield and the rear of the water tray. This will prevent some of the abrasive particles from flowing through the pump.

CAUTION - Water Strainer Placement

ALWAYS position the **strainer** in the water tray in a manner that will allow the free movement of the conveyor cart, and clearance from the cutting blade and cutting action.

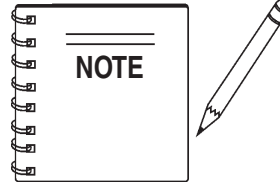

The mechanical water pump is shipped from the factory for **dry cutting** applications.

Wet Cutting Setup (Gasoline Only)

To connect the **mechanical water pump** to the drive V-belts for **Wet Cutting**, perform the following:

1. Loosen the 2 hex head cap screws (Figure 12) that secure the pump mount bracket.
2. **Push** the pump handle **downward** to engage the pump. The drive belt should have approximately 1/8 to 3/16 inch belt deflection.
3. Tighten the 2 hex head cap screws that secure the pump mount bracket.

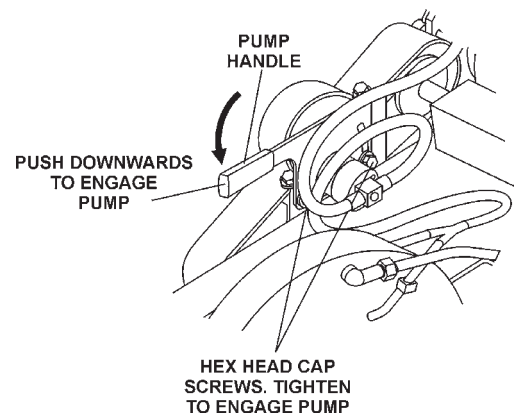

Figure 12. Pump Engage

4. With the engine running, squeeze the water pump **priming bulb** (Figure 13) until water begins to flow through the water lines. If the pump is working correctly, the cutting blade should be covered with a steady water mist. This will keep the blade cool while cutting.

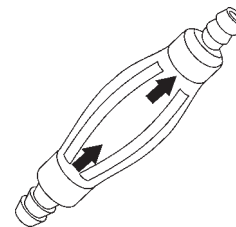

Figure 13. Priming Bulb

MP2 "MASON PRO" SAW — PRE-SETUP (GASOLINE ENGINE)

Dry Cutting Setup (Gasoline Only)

⚠ CAUTION - Dry Cutting

ALWAYS use the **water feed system** unless special **dry cut blades** are being used. If dry cutting is required **disconnect** water pump.

To disconnect the **mechanical water pump** from the drive V-belts for **Dry Cutting**, perform the following:

1. Loosen the 2 hex head cap screws (Figure 14) that secure the pump mount bracket.
2. **Pull** the pump handle **upward** to disengage the pump.
3. Tighten the 2 hex head cap screws that secure the pump mount bracket.

Figure 14. Pump Disengage

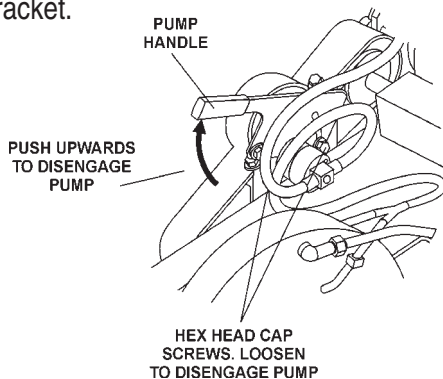

Before Starting

1. Read safety instructions at the beginning of manual.
2. Clean the saw, removing dirt and dust, particularly the engine cooling air inlet, carburetor and air cleaner.
3. Check the air filter for dirt and dust. If air filter is dirty, replace air filter with a new one as required.
4. Check carburetor for external dirt and dust. Clean with dry compressed air.
5. Check fastening nuts and bolts for tightness.



Engine Oil Check

1. To check the engine oil level, place the saw on a secure level surface with the engine stopped.
2. Remove the filler dipstick from the engine oil filler hole (Figure 15) and wipe clean.

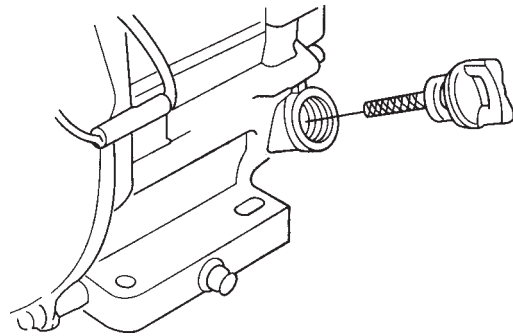

Figure 15. Engine Oil Dipstick (Removal)

3. Insert and remove the dipstick without screwing it into the filler neck. Check the oil level shown on the dipstick.
4. If the oil level is low (Figure 16), fill to the edge of the oil filler hole with the recommended oil type (Table 5). Maximum oil capacity is 1.16 quarts (1.1 liters)

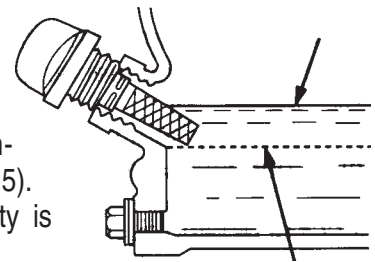

Figure 16. Engine Oil Dipstick (Oil Level)

TABLE 5. OIL TYPE

Season	Temperature	Oil Type
Summer	25°C or Higher	SAE 10W-30
Spring/Fall	25°C~10°C	SAE 10W-30/20
Winter	0°C or Lower	SAE 10W-10

⚠ CAUTION - Explosive Fuel

Motor fuels are highly flammable and can be dangerous if mishandled. **DO NOT** smoke while refueling. **DO NOT** attempt to refuel the pump if the engine is **hot!** or **running**.



Fuel Check

1. Remove the gasoline cap located on top of fuel tank.
2. Visually inspect to see if the fuel level is low. If fuel is low, replenish with unleaded fuel.
3. When refueling, be sure to use a strainer for filtration. **DO NOT** top-off fuel. Wipe up any spilled fuel **immediately!**

MP2 "MASON PRO" SAW — STARTUP/SHUTDOWN (ELECTRIC MOTORS)

Start-up (Electric Motor)

! CAUTION - Read this Manual before Starting!



Read and fully understand this manual before **starting or attempting to operate the saw**.

Before starting the saw's electric motor make sure that the **Safety, General Information, Inspection and Pre-setup** sections have been completed and understood. **DO NOT** proceed until the above mentioned sections have been completed.

! DANGER - Amputation Hazard

NEVER place hands and fingers near the cutting blade. The possibility exists of severe bodily harm if hands and fingers come in contact with rotating saw blade.



! CAUTION - Blade Guard Safety

ALWAYS ensure that the cutting blade has been mounted correctly and that it is raised above the surface you are about to cut.



1. Turn the power **ON/OFF** switch (Figure 17) to the **ON** position with the blade away from the material to be cut, the cutting blade should begin to rotate. Before cutting remember to follow all safety rules referenced in this manual.

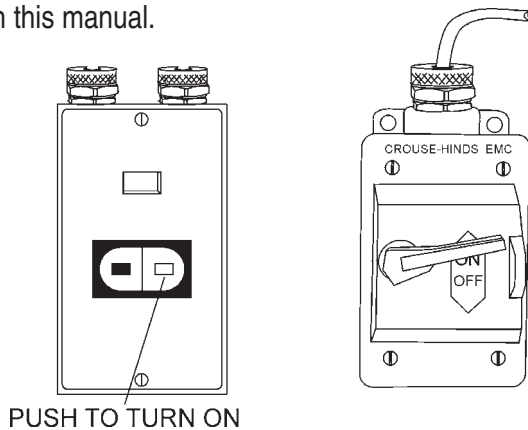
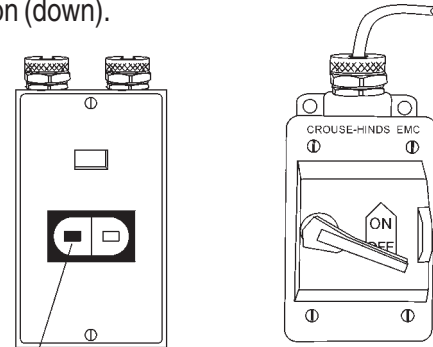

Figure 17. Power ON/OFF Switch (ON)

2. Avoid overloading the motor when cutting. The electric motors are protected with a manual-reset thermal overload switch that will turn the saw off if the motor is overheated. In the event that the switch is tripped, turn the **ON/OFF** switch to the **OFF** position and allow the motor to cool before attempting to restart.

Shutdown Procedure

1. Place the power **ON/OFF** switch (Figure 18) in the **OFF** position (down).



PUSH TO TURN OFF

Figure 18. Power ON/OFF Switch (OFF)

2. Wait for the cutting blade to stop rotating.
3. Disconnect the saw's **AC power cord** from the power source.

! CAUTION - Leaving the Saw Unattended

NEVER leave the saw connected to a power source when unattended. This will prevent accidental starting and potential injury.

4. Using a soft cloth, clean any excess debris or residue that may have accumulated on the saw.
5. Store saw in a clean dry location where it will be out of the reach of children.

MP2 "MASON PRO" SAW — STARTUP/SHUTDOWN (GASOLINE ENGINE)

Start-up Gasoline Engine

⚠ CAUTION - Read this Manual before Starting!



Read and fully understand this manual before **starting or attempting to operate the saw**.

Before starting the saw's electric motor make sure that the **Safety, General Information, Inspection** and **Pre-setup** sections have been completed and understood. **DO NOT** proceed until the above mentioned sections have been completed.

⚠ CAUTION - Dry Cutting Precautions

ALWAYS use the **water feed system** unless special **dry cut blades** are being used. If dry cutting is required disconnect water pump.

⚠ WARNING - Amputation Hazard

NEVER place hands and fingers near the cutting blade. The possibility exist of severe bodily harm if hands and fingers come in contact with rotating saw blade.



⚠ CAUTION - Blade Guard Safety

ALWAYS ensure that the cutting blade has been mounted correctly and that it is raised above the surface you are about to cut.



1. Place the **fuel valve lever** (Figure 19) to the **ON** position.

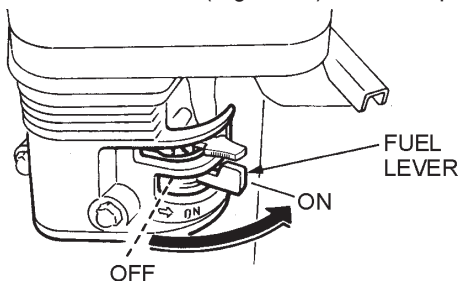

Figure 19. Engine Fuel Valve Lever

2. Place the **Engine ON/OFF switch** (Figure 20) in the **ON** position.

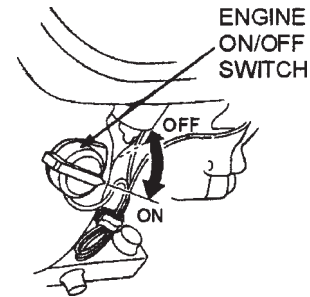
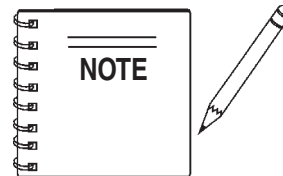

Figure 20. Engine ON/OFF Switch



The **CLOSED** position of the choke lever enriches the fuel mixture for starting a **COLD** engine. The **OPEN** position provides the correct fuel mixture for normal operation after starting, and for restarting a warm engine.

3. Place the **Choke Lever** (Figure 21) in the **CLOSED** position.

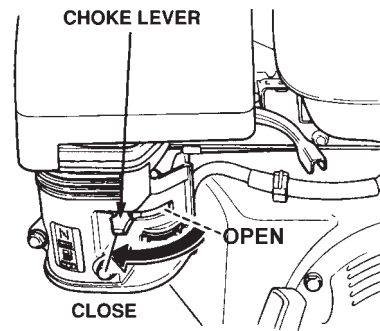

Figure 21. Choke Lever

4. Rotate the **throttle lever** (Figure 22) halfway between **fast** and **slow** for starting. All cutting is done at **full throttle**. The engine governor speed is factory set to ensure optimum blade operating speeds.

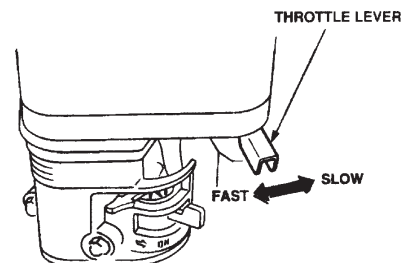

Figure 22. Throttle Lever

MP2 "MASON PRO" SAW — STARTUP/SHUTDOWN (GASOLINE ENGINE)

5. Grasp the starter grip (Figure 23) and slowly pull it out. The resistance becomes the hardest at a certain position, corresponding to the compression point. Pull the starter grip briskly and smoothly for starting.

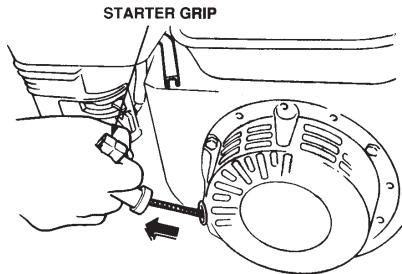

Figure 23. Starter Grip

! CAUTION - Engine Starter Rope Safety

DO NOT pull the starter rope all the way to the end. **DO NOT** release the starter rope after pulling. Allow it to rewind as soon as possible. Failure to do so could damage your engine.

6. If the engine has started, slowly return the choke lever (Figure 21) to the **OPEN** position. If the engine has not started repeat steps 1 through 5.
7. Before the saw is placed into operation, run the engine for several minutes. Check for fuel leaks, and noises that would associate with loose guards and/or covers.
8. Gradually move the engine throttle lever toward the **fast** position. (*All cutting should be done at full throttle*).

! WARNING - Engine Speed when Cutting

ALWAYS cut with the saw at **FULL THROTTLE**. Attempting to cut with the saw at less than full throttle could cause the blade to bind or stop abruptly in the slab resulting in serious injury to the operator or others in the area.

9. Avoid overloading the engine when cutting. In the event that the engine becomes overloaded, turn the engine **ON/OFF** switch to the **OFF** position (Figure 25) and allow the engine to **cool** before attempting to restart.

! WARNING - Burn Hazard



Engine components can generate extreme heat. To prevent burns, **DO NOT** touch these areas while the engine is running or immediately after operations. **NEVER** operate the engine with heat shields or heat guards removed.

Stopping the Engine

1. Set the engine throttle lever to **slow** speed and let the engine idle for 3-5 minutes.
2. Turn the engine **ON/OFF** switch to the **OFF** position (Figure 25).
3. Place the fuel valve lever in the **closed** position.
4. Let the engine cool.
5. Using a soft cloth, clean any excess debris or residue that may have accumulated on the saw.
6. Store saw in a clean dry location where it will be out of the reach of children.

MP2 "MASON PRO" SAW — OPERATION

Operation

! DANGER - Amputation Hazard

ALWAYS be alert to the fact that there is a rotating blade on the saw and be extremely aware of your body position - especially your hands in relationship to the rotating blade. The possibility exists of **severe bodily harm even death** if your body comes in contact with the rotating saw blade.

The MP2 "Mason Pro" Saw has two methods available for cutting: Using the **step pedal** to lower the blade into the material or fixing the height of the blade before cutting using the **raise/lower crank handle** to allow for a constant cutting depth.

"Fixed Height" Cutting Method

1. Using the **Raise/Lower Crank Handle**, located above the step pedal, turn the handle **CLOCKWISE** to **LOWER** the saw blade to the required depth (Figure 24).

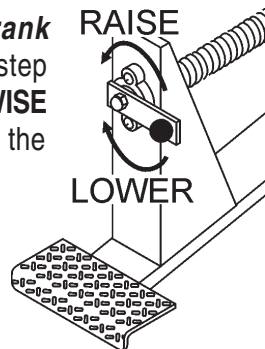

Turn the handle **COUNTER-CLOCKWISE** to **RAISE** the saw blade to the required depth.

Figure 24. Raise/Lower Crank Handle

2. Place the material to be cut (Figure 25) on the conveyor cart against the backstop.

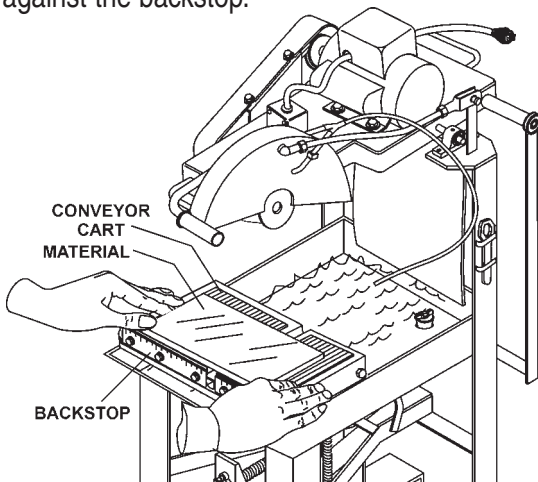

Figure 25. Material Placement

3. With the blade away from the material to be cut, start the Motor (or Engine) using the steps listed in the **Startup/Shutdown Procedure** (Electric Motors or Gasoline Engine).

4. Push the conveyor cart, with the material in place, slowly and evenly until the cut is complete. When finished cutting, move the cart back and remove the cut pieces.

! CAUTION - Dry Cutting Guidelines

NEVER lift the blade guard while the blade is rotating. The possibility exists of **severe bodily harm** if fingers or hands come in contact with the rotating saw blade. Wait for the blade to **stop rotating** before lifting the blade guard.



"Step Pedal" Cutting Method

1. Place the material to be cut (Figure 25) on the conveyor cart against the backstop.
2. With the blade away from the material to be cut, start the Motor (or Engine) using the steps listed in the **Startup/Shutdown Procedure** (Electric Motors or Gasoline Engine).
3. Move the conveyor cart, with the material in place, under the blade. Using your foot, depress the step pedal using a slow even pressure to lower the blade for cutting (Figure 26).

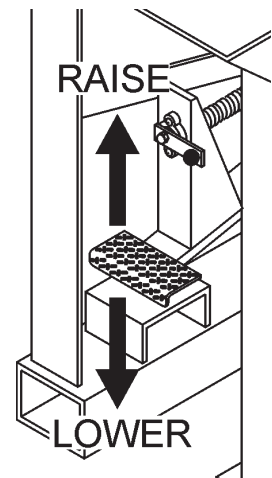
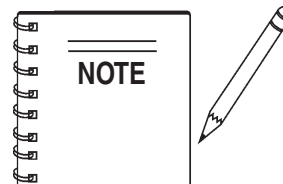

Figure 26. Raise/Lower Step Pedal



Jamming the blade into the object being cut will reduce the life of the blade and could damage the blade or material.

4. When finished cutting, slowly lift your foot up to raise the blade away from the conveyor cart and your cut material. Hold on to the mounting plate handle to prevent the plate from rising rapidly, possibly causing the saw to become unstable. **DO NOT** remove your foot from the step pedal until the blade has fully raised.

MP2 "MASON PRO" SAW — MAINTENANCE (SAW)

Maintenance

A good preventive maintenance program of regular inspection and care will increase life and improve the performance of the saw and cutting blades.

! WARNING - Shut-down the Saw for Maintenance

Whenever cleaning, adjusting, or lubricating any part of the saw, **MAKE CERTAIN** to do the following:

Electric Powered Saws

- Place power **ON/OFF** switch to the **OFF** position.
- Disconnect power cord from AC source.
- **NEVER** attempt to check the V-belt with the engine running. Severe bodily injury can occur.

Gasoline Powered Saws

- Turn the engine switch to the **OFF** position, disconnect the spark plug wire and secure it away from the spark plug.
- **NEVER** attempt to check the V-belt with the engine running. Severe bodily injury can occur.

Basic Maintenance

1. Tighten loose nuts or screws and replace any cracked or broken parts.
2. Clean the machine frequently. Remove the belt guard and clean the pulleys. The belts and pulleys will wear rapidly if excessive dust builds up.
3. Clean the sludge that accumulates on the bottom of the water tray at least once a day and refill with clean water. It may be necessary to clean the tray out twice a day in heavy cutting. The sludge is abrasive and will shorten the life of the water pump and blades.
4. After each day's use, clean the sludge from the bottom of the tray and run clean water through the water pump and water hoses. This extends pump and blade life.
5. Lubricate the blade adjustment rod after every eight (8) hours of use.
6. Check the spindle bolt for tightness periodically.
7. Keep the drive belts tight. It is very important to replace worn belts as soon as possible.
8. **MAKE CERTAIN** that the cutting head is aligned properly. Misalignment can adversely affect blade life.
9. The blade flanges must have a diameter of 4 in. Undersize flanges will reduce blade life and cause breakage. Therefore, they should be replaced at once.

10. Cutting blades must fit the arbor snugly. This is very important with diamond blades as pounding will occur and serious blade damage can result. If the arbor shoulder of the inner blade flange is grooved from blade slippage, the flange must be replaced.
11. Inspect the conveyor cart periodically. Replace the wood insert and wheels when necessary.
12. Lubricate spindle bearings after each day's operation. When dry cutting, grease bearings several times during the day's operation to protect them from the dust.
13. Replace the spindle bearings as soon as they begin to make any strange noises. Worn bearings can destroy blades very quickly.
14. Grease pivot bearings periodically.

Bearing Lubrication Care

There are two (2) grease points (Figure 27) for the MP2 (Electric Motors) and four (4) grease points for the MP2 (Gasoline Engine). Use only Premium Lithium 12 based Grease, conforming to NLG1 Grade #1 consistency. Grease *daily*.

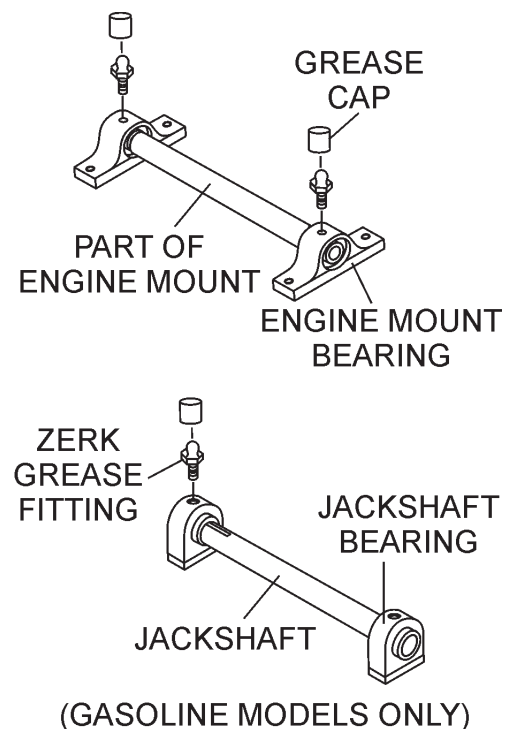

Figure 27. Zerk Fittings (Lubrication)

MP2 "MASON PRO" SAW — MAINTENANCE (SAW)

Adjust Belt Tension (Gasoline Powered Saws)

1. Remove engine-to-jackshaft and jackshaft-to-bladeshaft belt guards.

2. Check for proper belt tension on jackshaft-to-bladeshaft belts and engine-to-jackshaft belts.

4-5 lbs of force applied to the mid-point between jackshaft and bladeshaft pulleys should deflect the belt approximately 3/16" on a used belt.

4-5 lbs of force applied to the mid-point between engine and jackshaft pulleys should deflect the belt approximately 1/8".

To adjust engine-to-jackshaft belts only:

1. Loosen engine mounting bolts.
2. Adjust engine adjusting nuts to apply proper tension while maintaining pulley alignment and belt parallelism. Check pulley alignment and parallelism with a straight edge from jackshaft pulley to engine pulley.

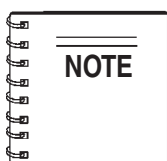

It is very important that the jackshaft and blade arbor **remain parallel** to each other.

This can be accomplished by using the adjusting bolt located on the engine mounting plate to help keep the jackshaft from cocking.

3. When proper belt tension and parallelism have been achieved, tighten engine mounting bolts.

To adjust jackshaft-to-bladeshaft belt:

If the jackshaft-to-bladeshaft belt requires adjustment, it will also be necessary to adjust the engine-to-jackshaft belts.

1. Loosen the 4 jackshaft mounting bolts, the 4 engine mounting bolts, and the jackshaft adjuster screw jam nuts (Loosen the mounting bolts only enough for the jackshaft and the engine to slide easily.)

2. Adjust jackshaft-to-bladeshaft belt first. To increase tension, tighten adjuster on bladeshaft belt side. To help maintain belt parallelism, loosen the jackshaft adjuster screw on the engine side the same number of turns that the bladeshaft side adjuster screw was tightened. Using a straight edge on the bladeshaft pulley to the jackshaft pulley, check for pulley alignment and belt parallelism.

3. When belt tension is correct, pulleys are aligned, and belts are parallel, tighten jackshaft mounting bolts and adjuster screw jam nuts.

4. Check for proper engine-to-jackshaft belt tension (4-5 lbs with 1/8" deflection at mid-point between pulleys.)

5. Adjust engine adjuster bolts to apply proper tension while maintaining pulley alignment and belt parallelism. Check pulley alignment and parallelism with a straight edge from jackshaft pulley to engine pulley.

6. When proper belt tension and parallelism have been achieved, tighten engine mounting bolts.

Reinstall belt guards. Test saw operation.

Adjust Belt Tension (Electric Powered Saws)

1. Remove the three belt guard screws securing the belt guard to the frame and remove the belt guard.

2. Loosen the four motor mounting bolts.

3. To increase belt tension, tighten the two adjusting nuts on the back of the motor plate.

Proper belt tension is 4-5 lbs. of force with approximately 3/16" of belt deflection measured at a point midway between the pulleys.

4. Adjust motor adjusting nuts to apply proper tension while maintaining pulley alignment and belt parallelism. Check pulley alignment and parallelism with a straight edge from motor pulley to bladeshaft pulley.

5. When proper belt tension and parallelism have been achieved, tighten engine mounting bolts and re-attach the belt guard.

MP2 "MASON PRO" SAW — MAINTENANCE (SAW)

Cutting Head Alignment (Blade)

When cutting with the MP2 "Mason Pro" Saw, make certain the **cutting head** is properly aligned horizontally and vertically with the conveyor cart. Misalignment can adversely affect blade life.

Horizontal Cutting Head Alignment:

1. Loosen the set screws (Motor Plate & Blade Guard Assy., Item 9) for the engine mount bearings.
2. Adjust the position of the cutting head horizontally until the blade is positioned within the middle of the cutting groove (Figure 28).
3. Slide the conveyor cart forward and backward on the tray to ensure that no part of the blade comes into contact with the groove. If the blade touches the side of the cart at any time, the cutting head is out of alignment. Repeat steps 1-3 until corrected.
4. Tighten the set screws.

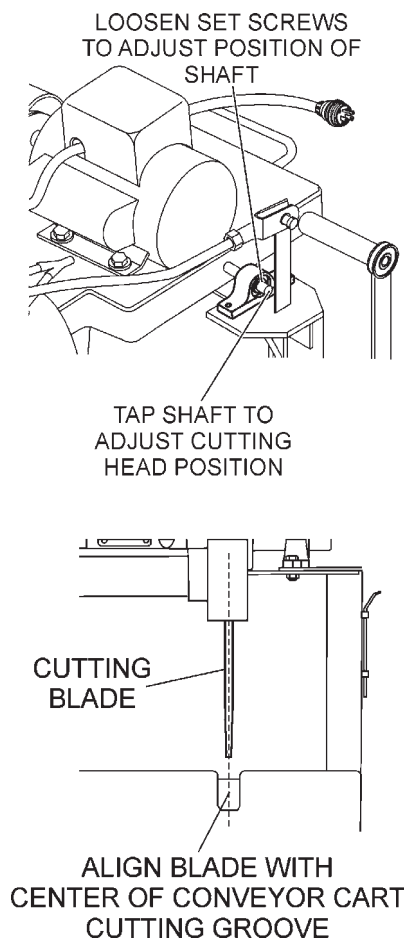

Figure 28. Cutting Head Alignment (Horizontal)

Checking Vertical Cutting Head Alignment:

Use the following procedures to check the vertical cutting head alignment. The MP2 "Mason Pro" Saw saw is factory shimmed to ensure proper vertical alignment. Should the cutting head become vertically misaligned, contact your local authorized service center to have the cutting head realigned.

⚠ CAUTION - Cutting Head Alignment

It is very important that the jackshaft and blade shaft **remain parallel** to each other. Self-alignment of the cutting head could result in damage to your material, machine or **bodily injury**.

1. Using a square or other straight edge device, check the vertical alignment of the blade by placing the bottom of the square on the conveyor cart and the side of the square against the blade (Figure 29).
2. If a gap exists between any part of the blade and square, the cutting head is out of alignment.

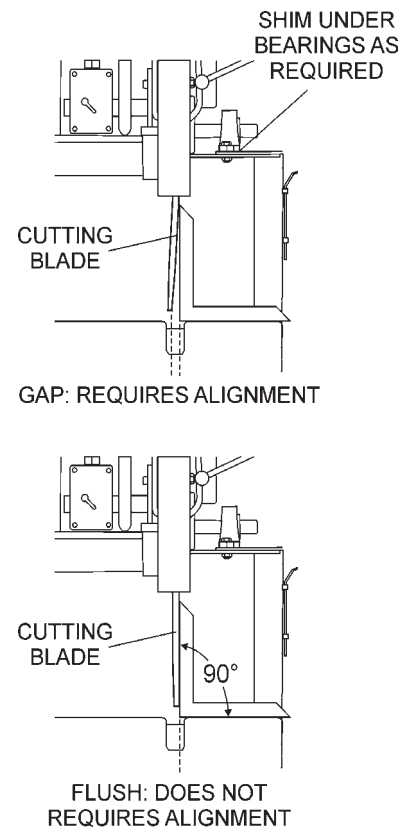

Figure 29. Cutting Head Alignment (Vertical)

MP2 "MASON PRO" SAW — MAINTENANCE (GASOLINE ENGINE)

Engine Maintenance

Perform engine maintenance procedures as referenced by Table 6 below:

TABLE 6. ENGINE MAINTENANCE SCHEDULE

DESCRIPTION (3)	OPERATION	BEFORE	FIRST MONTH OR 10 HRS.	EVERY 3 MONTHS OR 25 HRS.	EVERY 6 MONTHS OR 50 HRS.	EVERY YEAR OR 100 HRS.	EVERY 2 YEARS OR 200 HRS.
Engine Oil	CHECK	X					
	CHANGE		X				
Air Cleaner	CHECK	X					
	CHANGE			X (1)			
All Nuts & Bolts	Re-tighten If Necessary	X					
Spark Plug	CHECK-CLEAN				X		
	REPLACE						X
Cooling Fins	CHECK				X		
Spark Arrester	CLEAN					X	
Fuel Tank	CLEAN					X	
Fuel Filter	CHECK					X	
Idle Speed	CHECK-ADJUST					X (2)	
Valve Clearance	CHECK-ADJUST						X (2)
Fuel lines	CHECK	Every 2 years (replace if necessary) (2)					

(1) Service more frequently when used in **DUSTY** areas.

(2) These items should be serviced by your servc dealer, unless you have the proper tools and are mechanically proficient. Refer to the HONDA shop Manual for service procedures

(3) For commercial use, log hours of operation to determine proper maintenance intervals.

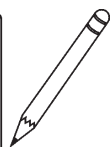
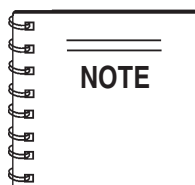

Reference manufacturer engine manual for specific servicing instructions.

MP2 "MASON PRO" SAW — MAINTENANCE (GASOLINE ENGINE)

Maintenance

Perform the engine maintenance procedures as indicated below:

Daily

- Thoroughly remove dirt and oil from the engine and control area. Clean or replace the air cleaner elements as necessary. Check and retighten all fasteners as necessary. Check the spring box and bellows for oil leaks. Repair or replace as needed.

Weekly

- Remove the fuel filter cap and clean the inside of the fuel tank.
- Remove or clean the filter at the bottom of the tank.
- Remove and clean the spark plug (Figure 30), then adjust the spark gap to 0.028 ~0.031 inch (0.6~0.7 mm). This unit has electronic ignition, which requires no adjustments.

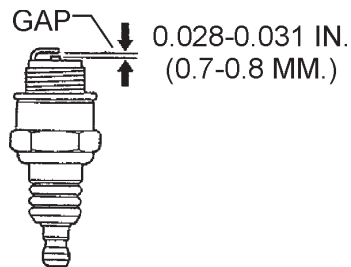

Figure 30. Spark Plug Gap

Engine Oil

- Drain the engine oil when the oil is **warm** as shown in Figure 31.
- Remove the oil drain bolt and sealing washer and allow the oil to drain into a suitable container.
- Replace engine oil with recommended type oil as listed in Table 5. Engine oil capacity is 1.16 quarts (1.1 liters). **DO NOT** overfill.
- Install drain bolt with sealing washer and tighten securely.

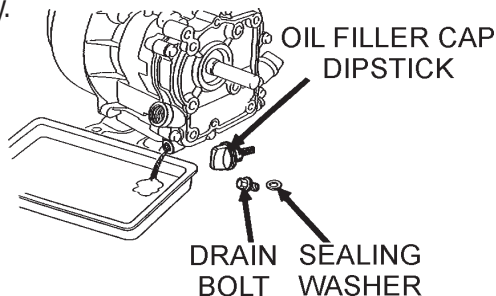

Figure 31. Engine Oil (Draining)

WARNING - Explosive Fuel



DO NOT use gasoline as a cleaning solvent, because that would create a risk of fire or explosion.

Engine Air Cleaner

- Remove the air cleaner cover and foam filter element as shown in Figure 34.
- Tap the paper filter element (Figure 32) several times on a hard surface to remove dirt, or blow compressed air [not exceeding 30 psi (207 kPa, 2.1 kgf/cm²)] through the filter element from the air cleaner case side. **NEVER** brush off dirt. Brushing will force dirt into the fibers. Replace the paper filter element if it is excessively dirty.
- Clean foam element in warm, soapy water or nonflammable solvent. Rinse and dry thoroughly. Dip the element in clean engine oil and completely squeeze out the excess oil from the element before installing.

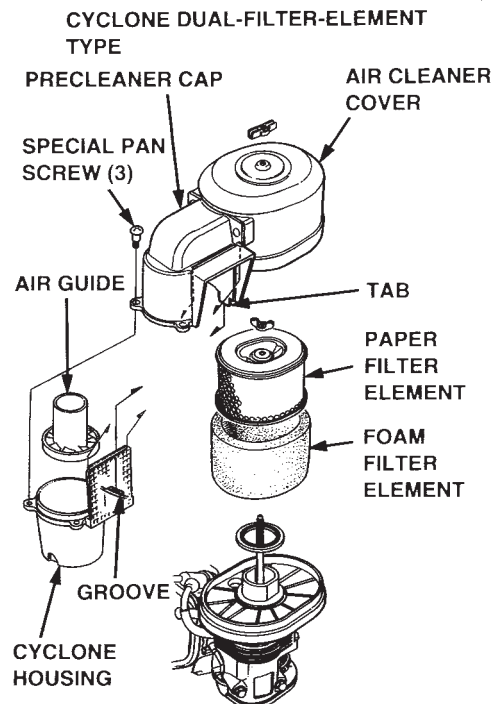

Figure 32. Engine Air Cleaner

MP2 "MASON PRO" SAW — ENGINE WIRING DIAGRAM

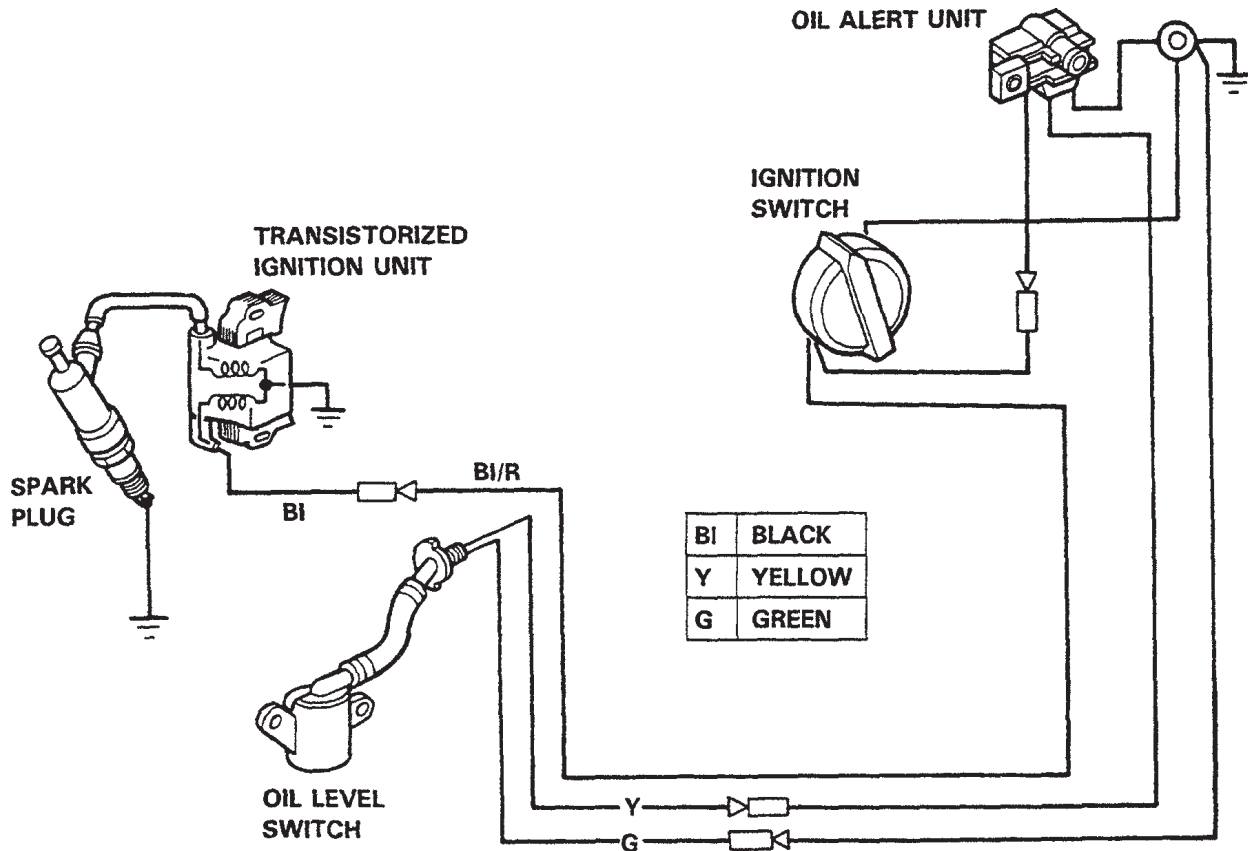

Figure 37. Honda GX270 QWH2 Engine Wiring Diagram

MP2 "MASON PRO" SAW — TROUBLESHOOTING - BLADE

Practically all breakdowns can be prevented by proper handling and maintenance inspections, but in the event of a breakdown, please take a remedial action following the diagnosis based on the Blade Troubleshooting (Table 7) information shown below and on the following page. If the problem cannot be remedied, please leave the unit just as it is and consult our company's business office or service plant.

TABLE 7. BLADE TROUBLESHOOTING

SYMPTOM	POSSIBLE PROBLEM	SOLUTION
Blade slows or stops cutting, still remains on blade	Blade too hard for the material being cut?	Consult Dealer or STOW for correct blade. Try cutting very soft material (sandstone, silica brick, cinder block) to "Redress" the blade.
	Engine torque diminished because of loose V-belt?	Tighten and/or replace V-Belt.
	Insufficient Engine power?	Check throttle setting. Check Engine horsepower.
	Improper direction of rotation?	Check that the blade is properly oriented and rotational arrow points in a "Down-Cutting" direction.
	Blade is slipping on the blade shaft?	Check that the blade & flange pin are properly installed on the blade shaft.
Blade does not cut straight and/or true.	Blade being used on misaligned saw?	Check blade shaft bearings and alignment integrity.
	Blade is excessively hard for the material being cut?	Check specification of the blade with the material being cut. Consult Dealer or STOW for information.
	Blade improperly mounted on arbor shoulders and flanges?	Ensure blade is properly affixed on the blade shaft.
	Excessive force applied to blade while cutting?	DO NOT force the blade in the cut. Apply a slow and steady pace when sawing.
Blade discoloring, crackling and/or wearing excessively.	Blades too hard for the material being cut?	Consult Dealer or STOW for correct blade. Try cutting very soft material (sandstone, silica brick, cinder block) to "Redress" the blade.
	Blade improperly mounted on arbor shoulders and flanges?	Ensure blade is properly affixed on the blade shaft.
	Blade not receiving enough cooling water or air?	Ensure proper flow & volume of water is provided for wet cutting blades. Ensure sufficient cooling air is circulated about a dry cutting blade.
	Arbor hole out of round?	Ensure blade is properly affixed on the blade shaft.
	Incorrect blade chosen for material being cut?	Check specification of the blade with the material being cut. Consult Dealer or STOW for information.
	Excessive force applied to blade while cutting?	DO NOT force the blade in the cut. Apply a slow and steady pace when sawing.

MP2 "MASON PRO" SAW — TROUBLESHOOTING (GASOLINE ENGINE)

Practically all breakdowns can be prevented by proper handling and maintenance inspections, but in the event of a breakdown, please take a remedial action following the diagnosis based on the Engine Troubleshooting (Table 8) information shown below and on the following page. If the problem cannot be remedied, please leave the unit just as it is and consult our company's business office or service plant.

TABLE 8. ENGINE TROUBLESHOOTING

SYMPTOM	POSSIBLE PROBLEM	SOLUTION
Difficult to start		
Fuel is available but spark plug will not ignite. (Power available at high tension cable).	Ignition plug being bridged (shorted)?	Check ignition system.
	Carbon deposit at ignition?	Clean or replace ignition.
	Short circuit due to defective insulators?	Replace insulators.
	Improper spark gap?	Set spark plug gap to the correct gap.
Fuel is available but spark plug will not ignite. (Power NOT available at high tension cable).	Short circuit at stop switch?	Check stop switch circuit. Replace stop switch if defective.
	Ignition coil defective?	Replace ignition coil.
Fuel is available and spark plug ignites (compression low).	Defective cylinder head gasket?	Tighten cylinder head bolts or replace head gasket.
	Cylinder worn?	Replace cylinder.
	Spark plug loose?	Tighten spark plug.
Operation not satisfactory		
Not enough power available (compression normal, no miss-firing).	Air cleaner clogged?	Clean or replace air cleaner.
	Fuel level in carbureator float chamber improper?	Adjust carbureator float
	Muffler clogged with carbon deposits?	Clean or replace muffler.
	Fuel in use inadequate (water, dust)?	Flush fuel sytem and replace with fresh fuel.
Not enough power available (compression normal, miss-firing).	Ignition coil defective?	Flush fuel sytem and replace with fresh fuel.
	Air in fuel line?	Bleed (remove air) from fuel line.
	Carbon deposits in cylinder?	Clean or replace cylinder
	Ignition plug often shorts?	Replace ignition wires, clean ignition.
	Fuel in use inadequate (water, dust)?	Flush fuel sytem and replace with fresh fuel.
Engine overheats.	Excessive carbon depostion in combustion chamber?	Clean or replace crankcase.
	Exhaust or muffler clogged with carbon.	Clean or replace muffler.
	Spark plug heat value incorrect?	Replace spark plug with correct type spark plug.

MP2 "MASON PRO" SAW — TROUBLESHOOTING (GASOLINE ENGINE)

TABLE 8. ENGINE TROUBLESHOOTING (CONTINUED)

SYMPTOM	POSSIBLE PROBLEM	SOLUTION
Operation not satisfactory		
Rotational speed fluctuates.	Governor adjustment improper?	Adjust governor to correct lever.
	Governor spring defective?	Clean or replace ignition.
	Fuel flow erratic?	Check fuel line.
Recoil starter not working properly.	Dust in rotating part?	Clean recoil starter assembly.
	Spiral spring failure?	Replace spiral spring.

MP2 "MASON PRO" SAW — TROUBLESHOOTING (ELECTRIC MOTOR)

Practically all breakdowns can be prevented by proper handling and maintenance inspections, but in the event of a breakdown, please take a remedial action following the diagnosis based on the Electric Motor Troubleshooting (Table 9) information shown below and on the following page. If the problem cannot be remedied, please leave the unit just as it is and consult our company's business office or service plant.

TABLE 9. TROUBLESHOOTING (ELECTRIC MOTOR)

SYMPTON	POSSIBLE PROBLEM	SOLUTION
Saw does not run when power is switch on.	Power cord plugged in?	Check that saw is properly connected to a power source.
	Defective power cord?	Replace power cord.
	Main power switch on saw defective?	Check and replace switch if necessary.
	Loose electrical connections?	Have electrical system checked by a qualified licensed electrician.
	Defective motor?	Check motor and replace if necessary.
Poor saw performance little power.	Power cord/extension cable too long?	Use a power cord/extension cable of rated length. See Table 4.
	Power source is insufficient?	Check electrical circuit. Circuit must be cable of supplying 20 amps minimum.
	Does motor run at rated speed?	Check motor and replace if necessary.
Motor stops (power cuts out)	Too much force exerted on the blade while cutting?	Exert less pressure when cutting.
	Incorrect saw blade?	Use a saw blade which corresponds to the material being cut.
	Defective electrical system?	Have electrical system checked by a qualified licensed electrician.

PAYMENT TERMS

Terms of payment for parts are net 10 days.

FREIGHT POLICY

All parts orders will be shipped collect or prepaid with the charges added to the invoice. All shipments are F.O.B. point of origin. Multiquip's responsibility ceases when a signed manifest has been obtained from the carrier, and any claim for shortage or damage must be settled between the consignee and the carrier.

MINIMUM ORDER

The minimum charge for orders from Multiquip is \$15.00 net. Customers will be asked for instructions regarding handling of orders not meeting this requirement.

RETURNED GOODS POLICY

Return shipments will be accepted and credit will be allowed, subject to the following provisions:

1. A Returned Material Authorization must be approved by Multiquip prior to shipment.
2. To obtain a Return Material Authorization, a list must be provided to Multiquip Parts Sales that defines item numbers, quantities, and descriptions of the items to be returned.
 - a. The parts numbers and descriptions must match the current parts price list.
 - b. The list must be typed or computer generated.
 - c. The list must state the reason(s) for the return.
 - d. The list must reference the sales order(s) or invoice(s) under which the items were originally purchased.
 - e. The list must include the name and phone number of the person requesting the RMA.
3. A copy of the Return Material Authorization must accompany the return shipment.
4. Freight is at the sender's expense. All parts must be returned freight prepaid to Multiquip's designated receiving point.

5. Parts must be in new and resalable condition, in the original Multiquip package (if any), and with Multiquip part numbers clearly marked.
6. The following items are not returnable:
 - a. Obsolete parts. (If an item is in the price book and shows as being replaced by another item, it is obsolete.)
 - b. Any parts with a limited shelf life (such as gaskets, seals, "O" rings, and other rubber parts) that were purchased more than six months prior to the return date.
 - c. Any line item with an extended dealer net price of less than \$5.00.
 - d. Special order items.
 - e. Electrical components.
 - f. Paint, chemicals, and lubricants.
 - g. Decals and paper products.
 - h. Items purchased in kits.
7. The sender will be notified of any material received that is not acceptable.
8. Such material will be held for five working days from notification, pending instructions. If a reply is not received within five days, the material will be returned to the sender at his expense.
9. Credit on returned parts will be issued at dealer net price at time of the original purchase, less a 15% restocking charge.
10. In cases where an item is accepted, for which the original purchase document can not be determined, the price will be based on the list price that was effective twelve months prior to the RMA date.
11. Credit issued will be applied to future purchases only.

PRICING AND REBATES

Prices are subject to change without prior notice. Price changes are effective on a specific date and all orders received on or after that date will be billed at the revised price. Rebates for price declines and added charges for price increases will not be made for stock on hand at the time of any price change.

Multiquip reserves the right to quote and sell direct to Government agencies, and to Original Equipment Manufacturer accounts who use our products as integral parts of their own products.

SPECIAL EXPEDITING SERVICE

A \$35.00 surcharge will be added to the invoice for special handling including bus shipments, insured parcel post or in cases where Multiquip must personally deliver the parts to the carrier.

LIMITATIONS OF SELLER'S LIABILITY

Multiquip shall not be liable hereunder for damages in excess of the purchase price of the item with respect to which damages are claimed, and in no event shall Multiquip be liable for loss of profit or good will or for any other special, consequential or incidental damages.

LIMITATION OF WARRANTIES

No warranties, express or implied, are made in connection with the sale of parts or trade accessories nor as to any engine not manufactured by Multiquip. Such warranties made in connection with the sale of new, complete units are made exclusively by a statement of warranty packaged with such units, and Multiquip neither assumes nor authorizes any person to assume for it any other obligation or liability whatever in connection with the sale of its products. Apart from such written statement of warranty, there are no warranties, express, implied or statutory, which extend beyond the description of the products on the face hereof.

OPERATIONS MANUAL

HERE'S HOW TO GET HELP

PLEASE HAVE THE MODEL AND SERIAL
NUMBER *ON-HAND* WHEN CALLING

MULTIQUIP CORPORATE OFFICE

18910 Wilmington Ave.
Carson, CA 90746
Email: mq@multiquip.com
Internet: www.multiquip.com

800-421-1244
FAX: 310-537-3927

PARTS DEPARTMENT

800-427-1244
310-537-3700

FAX: 800-672-7877
FAX: 310-637-3284

MAYCO PARTS

800-306-2926
310-537-3700

FAX: 800-672-7877
FAX: 310-637-3284

SERVICE DEPARTMENT

800-478-1244
310-537-3700

FAX: 310-537-4259

TECHNICAL ASSISTANCE

800-478-1244

FAX: 310-631-5032

WARRANTY DEPARTMENT

800-421-1244, EXT. 279
310-537-3700, EXT. 279

FAX: 310-537-1173

Your Local Dealer is:



MULTIQUIP INC.

18910 WILMINGTON AVE.
CARSON, CALIFORNIA 90746
800-421-1244 • 310-537-3700
FAX: 310-537-3927

E-mail: mq@multiquip.com
Internet: multiquip.com

Atlanta • Boise • Dallas • Houston • Newark
Montreal, Canada • Manchester, UK
Rio De Janeiro, Brazil • Guadalajara, Mexico

P/N: 35305