

# **TOSHIBA**



**TOSHIBA AMERICA INFORMATION SYSTEMS  
STORAGE DEVICE DIVISION  
IRVINE, CALIFORNIA**

**SR-M8102  
CD-R/CD-RW DRIVE  
USER MANUAL**

## CONTENTS

Introduction.....	1
Setup .....	3
Using the CD-R/CD-RW Drive .....	6
Troubleshooting.....	9
Specifications .....	10
Drive Connectors.....	13

## INTRODUCTION – SR-M8102

### General Features

CD-R/CD-RW disc write/rewrite at 52X/32X  
3-way Disc Eject (eject button, software, emergency eject hole)

Average Random Access Time

CD	110ms
CD-RW	120ms

Horizontal or Vertical Mount  
2MByte Buffer  
Playback interchangeability for CD-ROM discs  
BUS Interface - ATAPI

### Formats Compatibility

CD-DA (Red Book) - Standard Audio CD & CD-TEXT  
CD-ROM (Yellow Book Mode 1&2) - Standard Data  
CD-ROM XA (Mode 2 Form 1&2) - Photo CD, Multi Session  
CD-I/FMV (Green Book, Mode 2 Form 1&2, Ready, Bridge)  
CD-Extra/CD-Plus (Blue Book) - Audio & Text/Video  
Video-CD (White Book)- MPEG1Video  
CD-R (Orange Book Part II)  
CD-RW & HSRW (Orange Book Part III, Volume 1&2)  
USRW

## Front Panel

*Figure 1.SR-M8102 CD-R/RW Drive Front Panel*

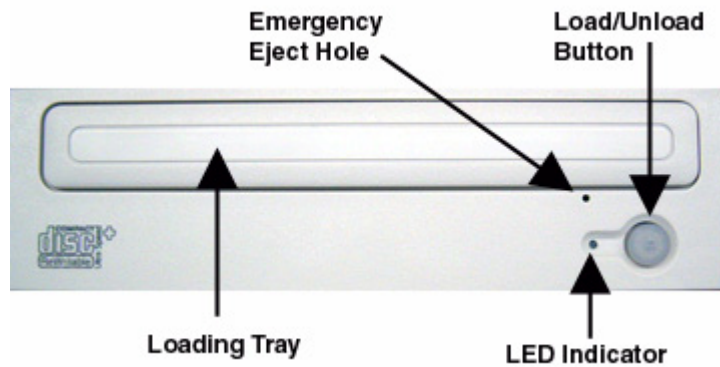

### **Loading Tray**

Load disc using tray.

### **LED**

The LED lights when the drive is operating

### **Load/Unload Button**

The Load/Unload button is used to open the disc tray so you can install or remove a disc.

### **Emergency Eject Hole**

The emergency eject hole is to be used only when the Loading Tray will not open when Eject button is pressed.

## SETUP – SR-M8102

The following steps must be performed to properly install your drive:

- Set Drive Jumper Settings
- Connect Audio Cable
- Attach IDE BUS Cable
- Attach Power Cable
- Mount Drive

### Jumper Settings

The mode select jumpers are 6 straight angle pins located on the rear of the CD-R/CD-RW drive. By placing a jumper on the pins, you can select the following functions:

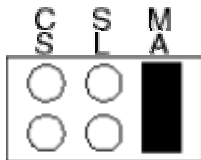

- CS Drive is configured using host interface signal CSEL
- SL Configures drive as Slave
- MA Configures drive as Master (default mode)

**Figure 1. Mode Select Jumper**

In most installations, jumper should remain in the MA position (factory default). It is recommended that you install your CD-R/CD-RW drive only on the secondary IDE BUS. If you are installing on primary IDE BUS, your hard drive would then be the Master, and you should set your CD-R/CD-RW drive to the Slave position (SL)

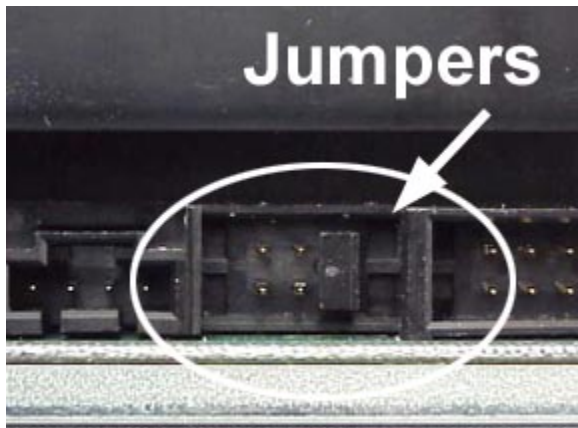

**Figure 2. Jumper Locations**

## Placing CD-R/CD-RW Drive inside your Computer

Now that you have set the jumpers, you are ready to install your CD-R/CD-RW drive inside your computer.

 **Important Note: Disconnect power from your computer system before beginning installation.**

Remove computer cover and faceplate if required. Refer to your computer systems manual for removal information. If the CD-R/CD-RW drive is replacing a CD-ROM or DVD-ROM, remove drive presently installed in your system.

Your Toshiba CD-R/CD-RW drive can be placed in any free half-height drive slot at the front of your computer. (It can be mounted horizontally or vertically.)

Carefully start sliding the CD-R/CD-RW drive into the opening with the disc tray facing the front of the computer. Before you push the drive all the way in you will need to connect the IDE BUS cable, Audio cable and the Power cable on the back of the drive.

### Connecting Cables

**IDE BUS Cable** (not supplied with drive) - Your computer system should have a primary and secondary IDE BUS, cable with your Hard Drive most likely being the Master on the primary BUS. Connect BUS cable as follows, assuring that pin 1 of cable (side with red stripe) is connected to pin 1 of the CD-R/CD-RW drive's interface connector:

*If you are replacing your CD-ROM or DVD:*  
connect CD-R/CD-RW drive to the BUS Cable connector that the CD-ROM or DVD was connected to.

*If CD-R/CD-RW drive is not replacing a CD-ROM/DVD or is an addition to a CD-ROM/DVD:*  
connect CD-R/CD-RW drive to an open connector on the secondary IDE BUS cable (not supplied with drive).

*If CD-R/CD-RW drive is to be slave on Primary BUS:*  
connect CD-R/CD-RW drive to open connector on the primary IDE BUS cable (not supplied with drive).

**Figure 3. Installing BUS Cable**



**Power Cable** - Connect an internal computer power supply cable to the power socket at the back of the CD-R/CD-RW drive. One side of the plug has chamfered edges, so the power connector fits only one way. Push plug completely into the socket making sure the plug fits correctly.



**Figure 4. Installing Power Cable**

**Audio Cable (optional)** - If you have a sound card and speakers, and would like to play audio CDs on your computer, you will need to install a CD/DVD audio cable. Toshiba's CD-R/CD-RW drives use a standard 4-pin audio cable that can be purchased from most local computer suppliers. The sound cable connects to your sound card at one end and the other end connects to the digital audio connector at the left rear of the CD-R/CD-RW drive (see CD-R/CD-RW drive Back Panel photo for location). Refer to the instructions that came with your sound card for details on any sound-driver software required.



**Figure 5. Installing Audio Cable**

### Completing Installation

After you have connected all the necessary cables, push the CD-R/CD-RW drive completely into the computers drive slot. Mount drive per your computers instructions. The screw length should not exceed 30.5mm (measured from outside surface of side or bottom of drive to tip of screw). Replace computer cover and all outer screws.

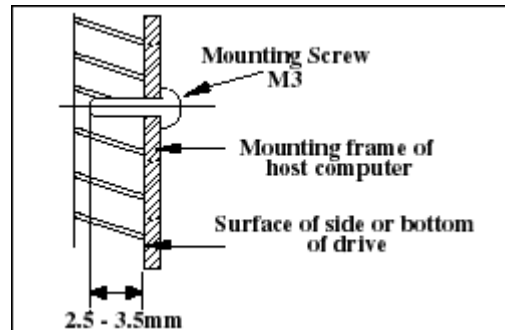

**Figure 6. Mounting Illustration**

**Software Driver** - Toshiba's optical drives do not require any unique device drivers for Windows '95/'98/2000/Me/XP/NT. After installing your drive and re-booting, your system should recognize your drive. Windows '95/'98/2000/Me/XP/NT Operating Systems support all Toshiba optical drives natively. If you prefer using DOS, download the DOS ATAPI driver from our web site.

**Other Software** - Additional software is required to use the SR-M8102 CD-R/-RW functions.

## USING THE CD-R/CD-RW Drive – SR-M8102

### Drive Operation

#### Inserting a Disc - Horizontally

To insert a disc into a drive that is mounted horizontally, perform the following steps:

**Figure 1. Inserting Disc**



1. Open the drive's Loading tray by pressing the Eject Button.
2. Place disc or into drive's Loading tray
3. Press Eject button again or gently push on the open disc tray. Tray will automatically close.

#### Inserting a Disc - Vertically

To insert a disc in a drive that is mounted vertically, perform the following steps:

1. Locate sliding disc holders (4 locations) on drive's Loading Tray.
2. The vertical position of the drive (eject button up or down) determines which of these four sliding disc holders are used (see photo below). Position the disc behind 3 of the disc holders, two on bottom, and one on upper rear, closest to drive). Using all four holders may cause the disc to not set properly in tray.
3. Slide the disc holders towards the center of tray using your finger, opened paper clip or the end of the emergency eject tool. The holder in the upper front side should be pulled away from the center of tray.
4. Position the disc behind disc holders on upper and rear side of tray. Then put disc behind bottom front holder

Check to see that all three disc holders are holding disc securely.

Close the drive by gently pushing in the tray or pressing the eject button.



**Figure 2. Inserting Disc Vertically**



### **Removing a Disc**

To remove a disc from the CD-R/CD-RW drive, perform the following steps:

1. Open the Loading Tray by pressing the Eject Button.
2. Slide disc holders away from disc.
3. Grasp disc by edges, and lift out of loading tray.
4. Press Eject Button again to close Loading Tray.

### **CD-RW Software**

Additional software is required to use the SR-M8102 CD-R/-RW functions

### **Usage Guidelines**

- Keep the disc tray closed when not using the CD-R/CD-RW Drive.
- Do not press down on the disc tray when opening or closing it.
- Do not place objects on the disc tray.
- Never use a damaged, broken, or deformed disc.
- Do not press the Open/Close button while the drive is accessing a disc.



*NOTE: High-speed drives spin the disc at a high rotational speed. If a disc has printing on only half of the disc, or if there is a slight imbalance in the disc, the imbalance is greatly magnified by the high speed, causing the drive to vibrate or produce a fan-like noise. These effects are inherent in the high-speed technology and do not indicate a problem with the drive.*

### **Emergency Ejection**



**CAUTION: The following procedure is intended only as a last resort when pressing the eject button fails to open the Loading Tray**

1. Turn computer power OFF by properly shutting down system.
2. Insert a solid bar (i.e. large paper clip) into Emergency Eject hole and push in until loading tray opens. Pull tray out.

**Figure 3.Using Emergency Eject**



### **Cleaning Media**

Try to avoid touching the read area (underside) of the disc as dirt and smears will degrade the disc accessing speed.

If the disc becomes dirty wipe it with a damp soft cloth. Avoid cleaning in a circular motion, but rather from the inner side outward.

## TROUBLESHOOTING – SR-M8102

Problem	Solution
Disc tray cannot be opened	<ul style="list-style-type: none"> <li>• Check that there is power to drive.</li> <li>• Use Emergency Eject instructions to open tray.</li> </ul>
Drive is not recognized by system	<ul style="list-style-type: none"> <li>• Is the drive connected properly? Are all cables plugged in properly (e.g. Power Cable, Interface Cable and Audio Cables).</li> <li>• Are the drive configuration jumpers on the CD-R/CD-RW drive set properly?</li> <li>• Is the software driver loaded? On a step-by-step (F8) Boot of the system is the CD-R/CD-RW drive recognized? (BIOS / DOS reports "device driver not found" or "no valid drivers selected."). If not, Contact Technical Support.</li> <li>• Has the CD-R/CD-RW drive software driver been corrupted by a virus. Run a Virus Scan program and repair if possible. Contact Technical Support if the Virus renders the CD-R/CD-RW drive software drivers not useable.</li> </ul>
Drive is not recognized by system during Boot process, but is recognized by the Operating System (i.e. XP, Win2000, Win98, Win NT, etc.)	<ul style="list-style-type: none"> <li>• Is the CD-R/CD-RW drive software driver loaded? On a step-by-step (F8) Boot of the system is the CD-R/CD-RW drive recognized? (BIOS / DOS reports "device driver not found"). If not, Contact Technical Support.</li> <li>• Has the Windows CD-R/CD-RW drive software driver program been corrupted by a virus. Run a Virus Scan program and repair if possible. Contact Technical Support if the Virus renders the software drivers not useable.</li> </ul>
BUSY Indicator LED flashes slowly	<ul style="list-style-type: none"> <li>• The disc may be dirty Clean it with a soft damp cloth. Avoid cleaning the disc using a circular motion. The disc should be wiped in a radial direction. That is, from the inner side outward.</li> <li>• The laser lens may have become cloudy or blocked by particulate matter. Please contact Technical Support.</li> </ul>
BUSY Indicator LED is constantly ON	<ul style="list-style-type: none"> <li>• Possible Hardware Problem. Please contact Technical Support.</li> </ul>
CD-R/RW can not play certain types of CD media (i.e. CD-plus, etc.)	<ul style="list-style-type: none"> <li>• Is the CD-R/CD-RW drive driver loaded</li> <li>• Is the CD disc the correct format for the type of system that you are using? (i.e. on a PC an ISO9660 IBM compatible PC format as opposed to Apple/Mac HFS disc or UNIX disc formats which will not function).</li> <li>• Do you have the correct software applications program/drivers installed to run a CD-R/RW disc?</li> <li>• Has the Windows CD-R/CD-RW drive software driver program been corrupted by a virus. Run a Virus Scan program and repair if possible. Contact Technical Support if the Virus renders the software drivers not useable.</li> </ul>

## SPECIFICATIONS –SR-M8102

### General

Interface	ATAPI
Format for Writing:	Disc at once, Track at once, Session at once, Variable & Fixed Packet write
Format Compatibility:	CD-DA (Red Book) - Standard Audio CD & CD-TEXT CD-ROM (Yellow Book Mode 1&2) - Standard Data CD-ROM XA (Mode 2 Form 1&2) - Photo CD, Multi Session CD-I/FMV (Green Book, Mode 2 Form 1&2, Ready, Bridge) CD-Extra/CD-Plus (Blue Book) - Audio & Text/Video Video-CD (White Book)- MPEG1 Video CD-R (Orange Book Part II) CD-RW & HSRW (Orange Book Part III, Volume 1&2) USRW
Media Compatibility	120mm CD-ROM (Read Only) 80mm CD (Horizontal Mount Only) 80/700/650 CD- Recordable (Read & Write) 700/650MB CD-Rewritable (Read& Write) 700/650MB High Speed CD-Rewritable (Read & Write) 700/650MB Ultra Speed CD-Rewritable (Read & Write)



*Note: All CD formats, except CD-Red Book (audio), require additional application specific software and/or hardware. The drive is capable of reading these data formats. However, in order to run applications that use these formats, you must first have the required software and/or hardware.*

### Performance

#### Read Speed:

CD-DA (Audio Play): Analog	8X CLV
CD-DA (DAE): Digital	48X CAV
Mixed CD: Audio	48X CAV
Mixed CD: Data	48X CAV
Video-CD	32X CAV
TOC Read	8X CAV

#### Write Speed:

CD-Recordable	52X CAV
CD-Rewritable (Standard Speed)	4X CLV
CD-Rewritable (High Speed)	10X/4X CLV
CD-Rewritable (Ultra Speed)	32X/24X P-CAV, 16XCLV

## Transfer Rate

CD-ROM Read (Mode 1)	7,800KB/second
CD-R/RW Read (Mode 1)	6,000KB/second

## Random Access Time

CD-ROM	110ms
CD-RW	120ms

Data Buffer	2MB
-------------	-----

## Environmental

### Ambient Temperature

Operating	5° to 45° C (41° to 113° F)
Storage	-25° to 60° C (13° to 140° F)

### Relative Humidity

Operating	10% to 80%
Storage/Shipping	10% to 95%

### Vibration

Operating (Random)	0.5Grms 15min
Non-operating (10 to 500Hz)	0.712Grms 15min

### Shock

Operating (Read)	11 msec 6G, 2msec 60G
Operating (Write)	11msec 3G
Non-operating	2msec 200G

Acoustical Noise	<54dBA
------------------	--------

## Power

DC Voltage and Current Requirements	DC +5V5%, DC12V 10%
-------------------------------------	---------------------

## Physical

Height	5.83" (148.2mm)
Width	1.65" (42mm)
Depth	7.24" (184mm)
Weight	1.650lbs (750g)

## **Connectors**

DC input	4-pin Power Supply Connector
ATAPI Interface Connector	40 Pin I/F ATAPI Standard
Audio Connectors	4-pin and 2-pin connector (use matching housing, Part No. 70066, made by Molex Corp, or equivalent)

## **Regulatory**

The SR-M8102 CD-R/RW has been certified by the following regulatory agencies

- UL 1950
- CSA C22.2 No. 950
- TUV (EN60950I)
- CE standard
- DHHS 21 CFR Sub-Chapter J
- FDA CFR21, EN60825

## DRIVE CONNECTORS –SR-M8102

Figure 1. SR-M8102 CD-R/CD-RW Drive Rear Panel - Connectors

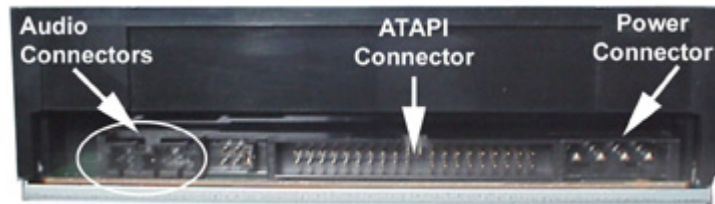

**Power Connector** Power is supplied to your CD-R/RW drive by the connection with your computer's +5V/+12V power cable to the power socket at the back of drive. One side of the plug has chamfered edges, so the power connector fits only one way.



**CAUTION:** Severe damage to the Drive circuits may occur if power cable is plugged in upside-down with power ON.

**Audio Connectors** Supplies Analog and Digital sound to your system.

**ATAPI Connector** The SR-M8102 CD-R/RW drive is connected to your computer system through the ATAPI connector.

**Table 1.Interface Pin Assignments**

INTERFACE PIN ASSIGNMENT							
PIN NO.	I/O	SIGNAL NAME	HOST SIGNAL NAME	PIN NO.	I/O	SIGNAL NAME	HOST SIGNAL NAME
1	I	Reset	Host Reset	21	O	HDRQ	DMA Request
2	-	GND		22	-	GND	
3	I/O	HD7	Host Data Bus BIT 7	23	I	HWR-,STOP	Host I/O Write
4	I/O	HD8	Host Data Bus BIT 8	24	-	GND	
5	I/O	HD6	Host Data Bus BIT 6	25	I	HRD-, HDMARDY, - HSTROBE	Host I/O Read
6	I/O	HD9	Host Data Bus BIT 9	26	-	GND	
7	I/O	HD5	Host Data Bus BIT 5	27	O	IORDY, DDMARDY,- DSTROBE	I/O Channel Ready
8	I/O	HD10	Host Data Bus Bit 10	28	-	CSEL	Cable Select
9	I/O	HD4	Host Data Bus BIT 4	29	I	HDAK-	DMA Acknowledge
10	I/O	HD11	Host Data Bus BIT 11	30	-	GND	
11	I/O	HD3	Host Data Bus BIT 3	31	O	INTRQ	Host Interrupt Request
12	I/O	HD12	Host Data Bus BIT 12	32	O	IOCS16-	Host 16 BIT I/O
13	I/O	HD2	Host Data Bus BIT 2	33	I	HA1	Host Address Bus BIT 1
14	I/O	HD13	Host Data Bus BIT 13	34	I/O	PDIAG-	Passed Diagnostics
15	I/O	HD1	Host Data Bus BIT 1	35	I	HA0	Host Address Bus BIT 0
16	I/O	HD14	Host Data Bus BIT 14	36	I	HA2	Host Address Bus BIT 2
17	I/O	HD0	Host Data Bus BIT 0	37	I	HCS1	Host CHIP Select 0
18	I/O	HD15	Host Data Bus BIT 15	38	I	HCS3	Host CHIP Select 1
19	-	GND		39	I/O	DASP-	Drive Active/Drive 1 Present
20	-	(KEYPIN)		40	-	GND	