

# **SY-P4I845PE Lite Motherboard**

## **Quick Start Guide**

**USB2.0 Driver  
Installation**

**Davicom  
Onboard LAN  
Driver**

**The SOYO CD**

**Quick BIOS  
Setup**

**Hardware  
Installation**

**Introduction**



1. AGP card with 3.3V is not supported, only AGP card with 1.5V can be used in this mainboard.
2. Please read the user guide before proceeding your installations. Serious damage may occur if the procedure is not followed properly.
3. If you have any problem getting your system to work, please follow the trouble shooting tips on page 25 of your user guide.
4. For immediate Technical questions, please visit [www.soyousa.com/support](http://www.soyousa.com/support), [www.soyousa.com/kb](http://www.soyousa.com/kb).
5. Make sure to use power supply for P4 motherboard. (preferably 350 watts or more)

# SY-P4I845PE Lite Motherboard

mPGA Socket 478 processors

Intel 845PE AGP/PCI Motherboard

533/400 MHz Front Side Bus supported

ATX Form Factor

Copyright © 2003 by SOYO Computer Inc.

**Trademarks:**

SOYO is a registered trademark of SOYO Computer Inc. All trademarks are properties of their owners.

**Product Rights:**

All names of the product and corporate mentioned in this publication are used for identification purposes only. The registered trademarks and copyrights belong to their respective companies.

**Copyright Notice:**

All rights reserved. This manual has been copyrighted by SOYO Computer Inc. No part of this manual may be reproduced, transmitted, transcribed, translated into any other language, or stored in a retrieval system, in any form or by any means, such as by electronic, mechanical, magnetic, optical, chemical, manual or otherwise, without permission in writing from SOYO Computer Inc.

**Disclaimer:**

SOYO Computer Inc. makes no representations or warranties regarding the contents of this manual. We reserve the right to amend the manual or revise the specifications of the product described in it from time to time without obligation to notify any person of such revision or amend. The information contained in this manual is provided to our customers for general use. Customers should be aware that the personal computer field is subject to many patents. All of our customers should ensure that their use of our products does not infringe upon any patents. It is the policy of SOYO Computer Inc. to respect the valid patent rights of third parties and not to infringe upon or to cause others to infringe upon such rights.

**Disclaimer**

Please be advised that some SOYO motherboards are designed with overclocking features and may allow users to run the components beyond manufacturer's recommended specifications. Overclocking beyond manufacturer's specifications is not recommended nor endorsed by SOYO, Inc. and will void your manufacturer's warranty. Overclocking beyond manufacturer's specifications is not encouraged and should be assumed at the user's own risk. Unsafe overclocking can damage the user's system or cause serious personal injury. If the user is unsure or in doubt about overclocking, please seek professional advise. SOYO, Inc. is not responsible for any direct or indirect damage resulting from overclocking.

**Restricted Rights Legend:**

Use, duplication, or disclosure by the Government is subject to restrictions set forth in subparagraph (c)(1)(ii) of the Rights in Technical Data and Computer Software clause at 252.277-7013.

**About This Guide:**

This Quick Start Guide can help system manufacturers and end users in setting up and installing the motherboard. Information in this guide has been carefully checked for reliability; however, to the correctness of the contents there is no guarantee given. The information in this document is subject to amend without notice.

For further information, please visit our **Web Site** on the Internet. The address is "<http://www.soyo.com.tw>".

**P4I845PE Lite Serial - Version 1.2 - Edition: February 2003**

\* These specifications are subject to amend without notice

---

## SY-P4I845PE Lite *Quick Start Guide*

---

# 1 Introduction

Congratulations on your purchase of the **SY-P4I845PE Lite** Motherboard. This *Quick Start Guide* illustrates the steps for installing and setting up your new Motherboard.

This guide provides all users with the basic steps of Motherboard setting and operation. For further information, please refer to the *SY-P4I845PE Lite Motherboard User's Manual* that came with your Motherboard.

## Unpacking

When unpacking the Motherboard, check for the following items:

---

◆ The SY-P4I845PE Lite Intel 845PE AGP/PCI Motherboard



---

◆ This Quick Start Guide



---

◆ The Installation CD-ROM



---

◆ SOYO Bonus Pack CD-ROM





---

◆ Two IDE Device ATA 100 Flat Cable

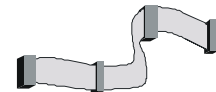

---

◆ One Floppy Disk Drive Flat Cable



---

◆ One Heat Sink Compound





---

◆ One Back panel

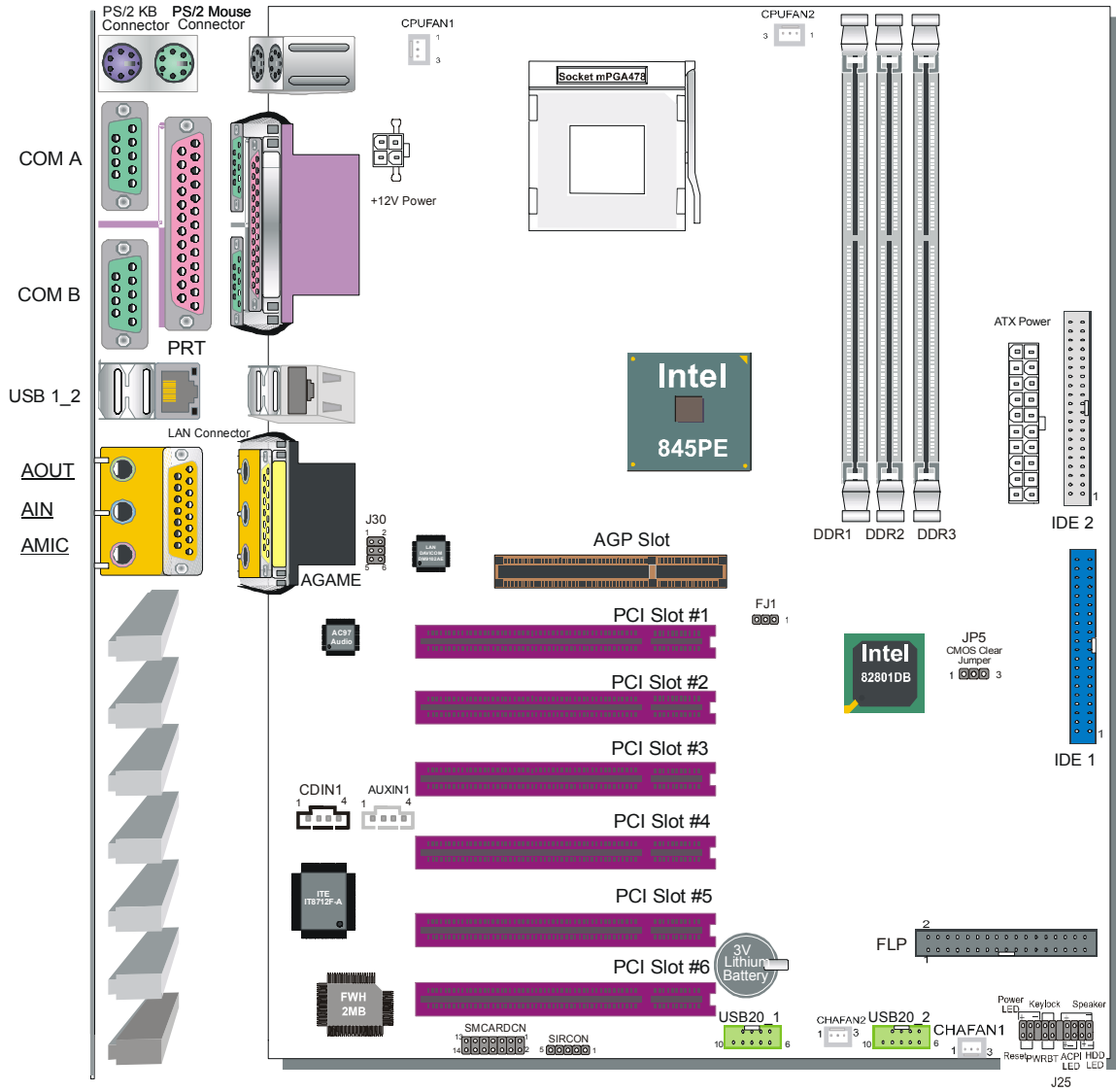

# SY-P4I845PE Lite Motherboard Layout



### Key Features

- Supports Intel® mPGA Socket 478 processors
  - Pentium® 4
- Supports 533/400 MHz Front Side Bus Frequency
- PC99, ACPI
- Ultra 33/66/100 (ATA 33/66/100)
- Supports Wake-On-LAN (WOL)
- Supports PC1600/PC2100/2700 Unbuffer DDR Module
- 3 x DIMM slots for DDR SDRAM memory, max RAM side up to 2GB
- Supports ACPI Suspend Indicator
- Power-on by PS/2 Keyboard
- Power failure resume
- Supports Suspend to RAM
- Supports onboard hardware monitoring and includes Hardware Doctor™ utility
- Supports AC97 4 channel Codec
- Easy CPU settings in BIOS with the “SOYO COMBO Setup”
  - CPU voltage adjust
  - CPU ratio adjust
  - CPU FSB adjust
  - DDR SDRAM voltage adjust
  - AGP voltage adjust
- Supports multiple-boot function
- AGP 2.0 Compliant; AGP Connector supports:
  - 1.5V only AGP cards
  - 4X data transfer
- Smart Card Reader
  - Compliant with Personal Computer Smart Card (PC/SC) Working Group standard
- 1 x 32-bit AGP slot
- 6 x 32-bit bus master PCI slots
- 6 x USB2.0 ports onboard
- 1 x IrDA port
- Support ATX 12V power
- On-board 10/100 mbps NIC

## 2 *Installation*



To avoid damage to your Motherboard, please follow these simple rules while handling this equipment:

- Before handling the Motherboard, ground yourself by touching on to an unpainted portion of the system's metal chassis.
- Remove the Motherboard from its anti-static packaging. Hold the motherboard by the edges and avoid touching its components.
- Check the Motherboard for damage. If any chip appears to be loose, press carefully to seat it firmly in its socket.

Follow the directions in this section which is designed to guide you through a quick and correct method to install your new **SY-P4I845PE Lite** Motherboard. For detailed information, please refer to the *SY-P4I845PE Lite Motherboard User's Manual and Technical Reference* online manual on the CD-ROM that came with your Motherboard.

Gather and prepare all necessary components to complete the installation successfully:

- ◆ Socket mPGA478 processor with built-in CPU cooling fan (boxed type)
- ◆ DDR SDRAM module (s)
- ◆ Computer case with adequate power supply unit
- ◆ Monitor
- ◆ PS/2 Keyboard
- ◆ Pointing Device (PS/2 Mouse)
- ◆ Speaker(s) (optional)
- ◆ Disk Drives: HDD, CD-ROM, Floppy drive...
- ◆ External Peripherals: Printer, Plotter, and Modem (optional)
- ◆ VGA Card (AGP, PCI)

## SY-P4I845PE Lite *Quick Start Guide*

---

### ***Install the Motherboard***

We will now begin the installation process. Please follow the systematic procedure designed to lead you to a complete and correct installation.

**Step 1-** Install the Central Processing Unit (CPU)

**Step 2-** Install memory modules

**Step 3-** Connect cables, case wires, and power supply Install expansion cards

**Step 4-** Install expansion cards

#### **Step 1. Install the CPU**

***CPU Mount Procedure:*** To mount the Pentium® 4 Socket mPGA478 processor that you have purchased separately, follow these instructions.

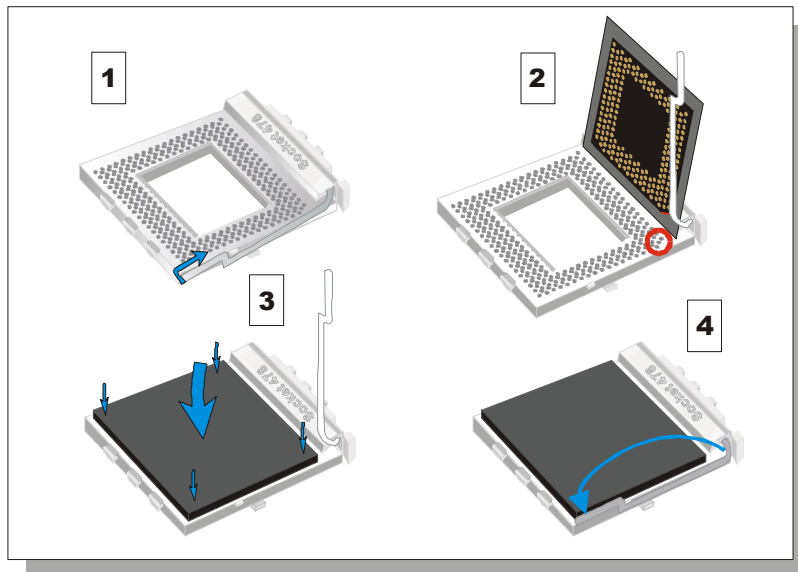

1. Lift the socket handle up to a vertical position.
2. Align the blunt edge of the CPU with the matching pinhole edge on the socket.
3. Seat the processor in the socket completely and without forcing.
4. Then close the socket handle to secure the CPU in place.



---

Remember to connect the CPU Cooling Fan to the appropriate power connector on the Motherboard. *The fan is a key component that stabilizes the system. It prevents the equipment from overheating and prolongs the life of your CPU.*

---



**FJ1 jumper (beside the AGP slot)**

This jumper sets the default boot-up CPU frequency and the group of FSB frequencies that can be selected in the BIOS.

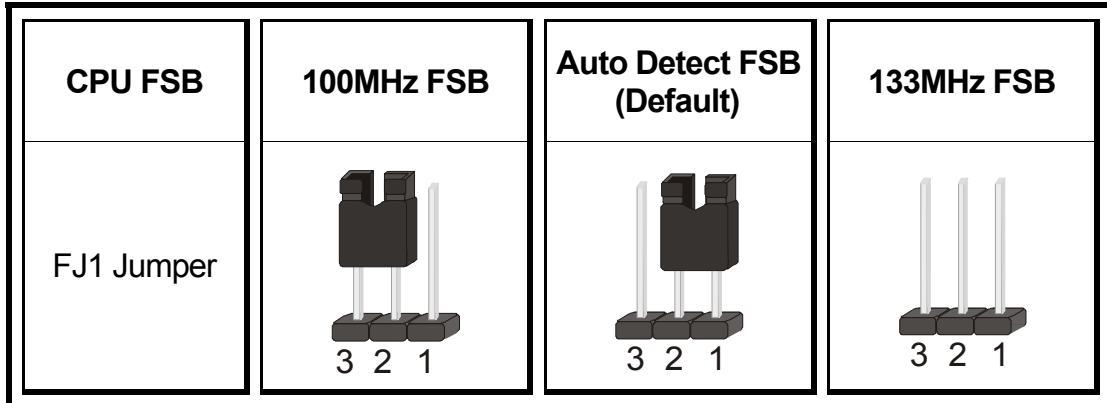

**Step 2. Configure Memory**

This motherboard support PC2100 and PC2700, non-ECC and non-registered module. **The largest memory capacity possible is 2GB.** On this motherboard, DRAM speed can be set independent from the CPU front side bus speed. **A maximum of 2 pcs.** **Double-sided module can be used at the same time.**

**Memory Configuration Table**

DDR1	DDR2	DDR3
Double sided	Double sided	None
Double sided	Single sided	None
Double sided	Single sided	Single sided
Single sided	Single sided	none

**Note:** System must have 533MHz FSB CPU to have PC2700 memory support.

**Memory Settings**

FJ1 jumper allows you to change the DRAM Frequency (DRAM multiplier) for this motherboard. This setting will have a corresponding DRAM multiplier table which can be modified by using the “DRAM: CPU multiplier” option in the BIOS.

## SY-P4I845PE Lite Quick Start Guide

### FJ1 Table:

FJ1	Available multiplier in the “DRAM:CPU multiplier” option
1-2 (default)	Auto detect
2-3	1.33
Open	1.00 / 1.25 / by SPD

Your memory frequency is dependent on your CPU front side bus frequency. It is calculated by:

Memory frequency. = DRAM multiplier (set in the CMOS setup) \* CPU front side bus frequency \* 2

#### Note:

- If you plan to use the memory at the default speed, set the FJ1 to 1-2 (auto detect)
- When using a 400MHz CPU, you need to set the FJ1 to 2-3 or 1-2. Setting FJ1 to open will not allow your system to boot-up.
- When using a 533MHz CPU, you can set FJ1 to 1-2, 2-3 or open, depending on the memory frequency you wish to use.

#### Example:

1. A system using a 400MHz CPU and a PC2100 memory module with FJ1 set as 1-2 or 2-3. Your current memory frequency is

$$400\text{MHz} / 4 = 100\text{MHz} * 1.33 = 133\text{MHz} * 2 \text{ (since it is a DDR module)} = 266\text{MHz}$$

2. A system using a 533MHz CPU and a PC2700 memory module with FJ1 set as open. The multiplier in the “DRAM:CPU Ratio” option in the bios is set to 1.25, your current memory frequency will be

$$533\text{MHz} / 4 = 133 \text{ MHz} * 1.25 = 166\text{MHz} * 2 \text{ (since it is a DDR module)} = 333\text{MHz}$$

### Step 3. Connect cables, case wires, and power supply Install expansion cards

This section tells how to connect internal peripherals and the power supply to the Motherboard.

The internal peripherals consist of IDE devices (HDD, CD-ROM), Floppy Disk Drive, Chassis Fan, Front Panel Devices (ACPI LED, Internal Speaker, Reset Button, IDE LED, and KeyLock Switch.), Wake-On-LAN card, VGA card, Sound Card, and other devices.

For more details on connecting internal and external peripherals to your new SY-P4I845PE Lite Motherboard, please refer to *SY-P4I845PE Lite Motherboard User's Manual and Technical Reference* online manual on the CD-ROM.

## SY-P4I845PE Lite Quick Start Guide

### Connectors and Plug-ins

CPU Cooling Fan: CPUFAN1					CPU Cooling Fan: CPUFAN2								
Pin1	Pin2	Pin3			Pin1	Pin2	Pin3						
GND	+12V	Sensor			GND	+12V	Sensor						
Chassis Fan: CHAFAN1					Chassis Fan: CHAFAN2								
Pin1	Pin2	Pin3			Pin1	Pin2	Pin3						
GND	+12V	Sensor			GND	+12V	NC						
CD-IN 1					AUXIN1								
Pin1	Pin2	Pin3	Pin4		Pin1	Pin2	Pin3	Pin4					
Left	GND	GND	Right		Left	GND	GND	Right					
Standard IrDA (Infrared Device Header): SIRCON					MIC & LED Connector: J30								
Pin1	Pin2	Pin3	Pin4	Pin5	Pin1	Pin2	Pin3	Pin4	Pin5	Pin6			
VCC	None	IRRX	GND	IRTX	Line_Out_L	Line_Out_R	MIC IN	GND	LAN_LINK_LED	VCC			
USB20_1													
Pin1	Pin2	Pin3	Pin4	Pin6	Pin7	Pin8	Pin9	Pin10					
VCC	DATA-	DATA+	GND	VCC	DATA-	DATA+	GND	GND					
USB20_2													
Pin1	Pin2	Pin3	Pin4	Pin6	Pin7	Pin8	Pin9	Pin10					
VCC	DATA-	DATA+	GND	VCC	DATA-	DATA+	GND	GND					
SMCARDCN													
Pin1	Pin2	Pin3	Pin4	Pin5	Pin6	Pin7	Pin8	Pin9	Pin10	Pin11	Pin12	Pin13	Pin14
VCC	NC	NC	NC	Scrfet	RST	CLK	NC	NC	Scrio	GND	Scrpres	NC	NC
					Power LED				Key Lock				
					Pin11	Pin12	Pin13	Pin14	Pin15				
					VCC	NC	GND	Control Pin	GND				
					Speaker								
Pin17	Pin18	Pin19	Pin20										
VCC	NC	NC	Speaker out										
HDD LED		ACPI LED		PWRBT		RESET							
Pin9	Pin10	Pin7	Pin8	Pin4	Pin5	Pin1	Pin2						
LED Anode	LED Cathode	2.5V_DDR	Control Pin	Power On/Off	GND	Control PIN	GND						

## SY-P4I845PE Lite Quick Start Guide

### Power On/Off: PWRBT

Connect your power switch to this header (momentary switch type).

**To turn off the system, press this switch and hold down for longer than 4 seconds.**

### ATX 12V Power Supply: ATX PW

Attach the ATX 12V Power cable to three connector. (This motherboard requires an ATX 12V power supply, an AT and ATX power supply can NOT be used.)

*When using the Power-On by PS/2 Keyboard function, please make sure the ATX power supply is able to provide at least 720mA on the 5V Standby lead (5VSB).*

**PS. Power supply must be use ATX 12V specification.**

A new superset of the original ATX power supply is now defined. Named "ATX 12V," this new power supply is comprised of a standard ATX unit plus the following enhancements:

- Increased +12 VDC output capability. Mother board components with unique voltage requirements are increasingly expected to be powered via DC/DC converters off the +12 VDC power supply output. This trend is due primarily to the higher power conversion and transmission efficiencies of +12 VDC relative to +5 VDC or +3.3 VDC. ATX12V power supplies should be designed to accommodate these increased +12 VDC current requirements and to address associated issues such as cross-regulation, capacitive loading, transient surge tolerance, cable voltage drop, and cooling.
- New +12 V power connector. To enable the delivery of more +12 VDC current to the motherboard, a new 4-pin receptacle/header combination--the + 12 V power connector--has been defined. **The presence of the +12 V power connector indicates that a power supply is ATX12V; the absence of the +12 V power connector indicates that a supply is ATX.**

Please install the ATX power according to the following pin assignment:

### ATX Power

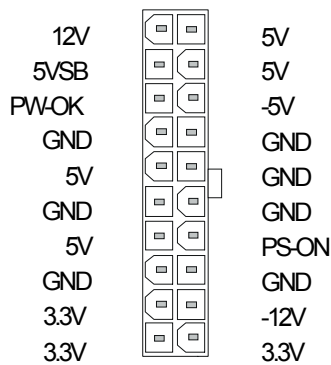

➤ **Pay special care to the directionality.**

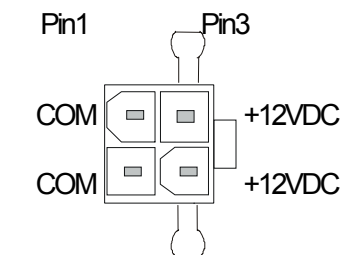

+12V Power Connector

### Step 4. Install expansion cards

The motherboard has 1 AGP slot and 6 PCI slots.

1. Read the instruction document of the related expansion card before inserting the expansion card into the computer.
2. Press the expansion card firmly into expansion slot in motherboard.
3. Be sure the metal contacts on the card is seated in the slot.
4. Replace the screw to secure the slot bracket of the expansion card.
5. Install related driver from the operating system.



---

**Note1:** Only AGP card with 1.5 volts can be used in this M/B. Using 3.3 volts AGP card will damage your motherboard. For AGP card voltage specification, please check the AGP card manual or contact your AGP card manufacturer.

---



---

**Note2:** When you use an AGP add-in card on the P4I845PE Lite mainboard the onboard VGA will automatically be disabled. It's not possible to use onboard VGA and an AGP add-in card at the same time. For this versions (P4I845PE Lite) note that when using a PCI VGA card, make sure that the init display setting is set to PCI slot instead of onboard/AGP. Also, note that when using a PCI VGA card the on chip VGA setup option can be used to disable onboard VGA.

---

### CMOS Clear (JP5)

In some cases the CMOS memory may contain wrong data, follow the steps below to clear the CMOS memory.

1. Clear the CMOS memory by momentarily shorting pin 2-3 on jumper JP5. This jumper can be easily identified by its white colored cap.
2. Then put the jumper back to 1-2 to allow writing of new data into the CMOS memory.

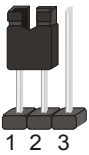
CMOS Clearing	Clear CMOS Data	Retain CMOS Data
<b>JP5 Setting</b>	Short pin 2-3 for at least 5 seconds to clear the CMOS 	Short pin 1-2 to retain new settings 
<i>Note: You must unplug the ATX power cable from the ATX power connector when performing the CMOS Clear operation.</i>		

### Audio Speakers connections

When using 2 channel speaker, connect the speaker cable to line-out.

If you're using 4 channel speaker, connect **the front L/R speakers to line-out and rear L/R speakers to Line-in**. make sure to set the audio software for 4 channel speaker system. Don't forget to set the Audio Rack software to 4 channel system.

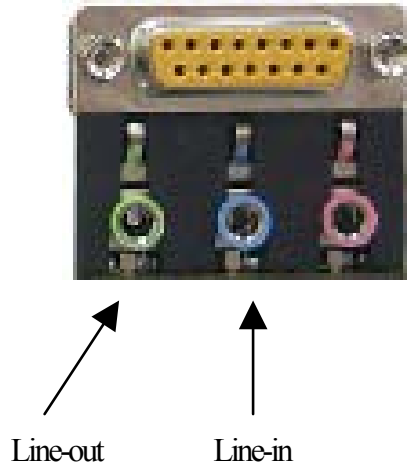

### Onboard LAN LED Definition

When this LED is lit, this means the LAN is running at 100 mbps, if it is not lit, the Onboard LAN is working at 10 mbps.

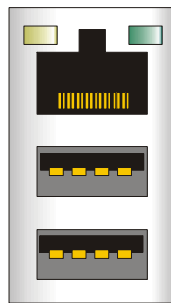

This is the LAN activity LED. It will blink when it is active.

## 3 **Quick BIOS Setup**

This Motherboard does not use any hardware jumpers to set the CPU frequency. Instead, CPU settings are software configurable with the BIOS **[SOYO COMBO FEATURE]**. The **[SOYO COMBO FEATURE]** combines the main parameters that you need to configure, all in one menu, for a quick setup in BIOS.

After the hardware installation is complete, turn the power switch on, then press the **<DEL>** key during the system diagnostic checks to enter the Award BIOS Setup program. The CMOS SETUP UTILITY will be shown on the screen. Then, follow these steps to configure the CPU settings.

**Step 1. Select [STANDARD CMOS SETUP]**

Set [Date/Time] and [Floppy drive type], then set [Hard Disk Type] to "Auto".

**Step 2. Select [LOAD OPTIMIZED DEFAULTS]**

Select the "LOAD OPTIMIZED DEFAULTS" menu and type "Y" at the prompt to load the BIOS optimal setup.

**Step 3. Select [SAVE & EXIT SETUP]**

Press **<Enter>** to save the new configuration to the CMOS memory, and continue the boot sequence.



## 4 **The SOYO CD**



**The SOYO-CD will Auto Run only in Windows Base Operating System.**

Your SY-P4I845PE Lite motherboard comes with a CD-ROM labeled “SOYO CD”. The SOYO CD contains

- a. The user’s manual for your new motherboard in PDF format,
- b. The drivers software available for installation, and
- c. A database in HTML format with information on SOYO motherboards and other products.

### **Step 1. Insert the SOYO CD into the CD-ROM drive**

If you use Windows NT or 2000, the SOYO-CD will not detect your motherboard type. In that case the following dialog will pop up, please choose your motherboard and press OK. Now the SOYO-CD Start Up Menu will be shown.

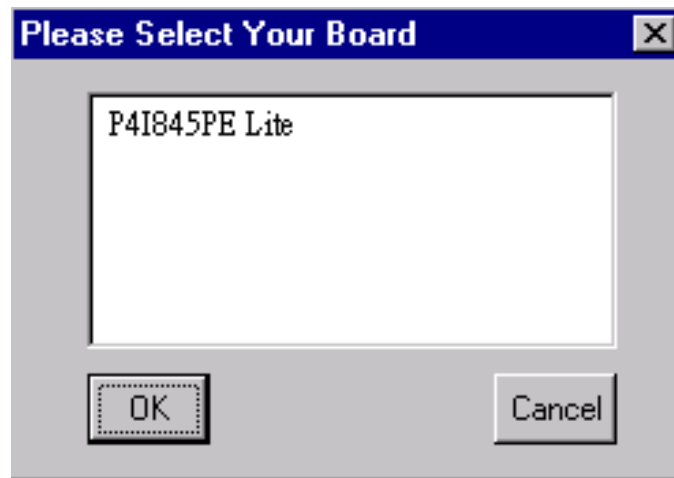

**(SOYO CD Start Up Program Menu)**

If you use Windows 95/98/98SE/ME, the SOYO CD Start Up Program automatically detects which SOYO Motherboard you own and displays the corresponding model name.

## SY-P4I845PE Lite *Quick Start Guide*



The user's manual files included on the SOYO CD are in PDF (Postscript Document Format). In order to read a PDF file, the appropriate Acrobat Reader software must be installed in your system.

**Note:** The Start Up program automatically detects if the Acrobat Reader utility is already present in your system, and otherwise prompts you on whether or not you want to install it. You must install the Acrobat Reader utility to be able to read the user's manual file. Follow the instructions on your screen during installation, then once the installation is completed, restart your system and re-run the SOYO CD.

### **Step 2. Install Drivers and Utilities**

Click the **Install Drivers** button to display the list of drivers software that can be installed with your Motherboard. The Start Up program displays the drivers available for the particular model of Motherboard you own. We recommend that you only install those drivers.

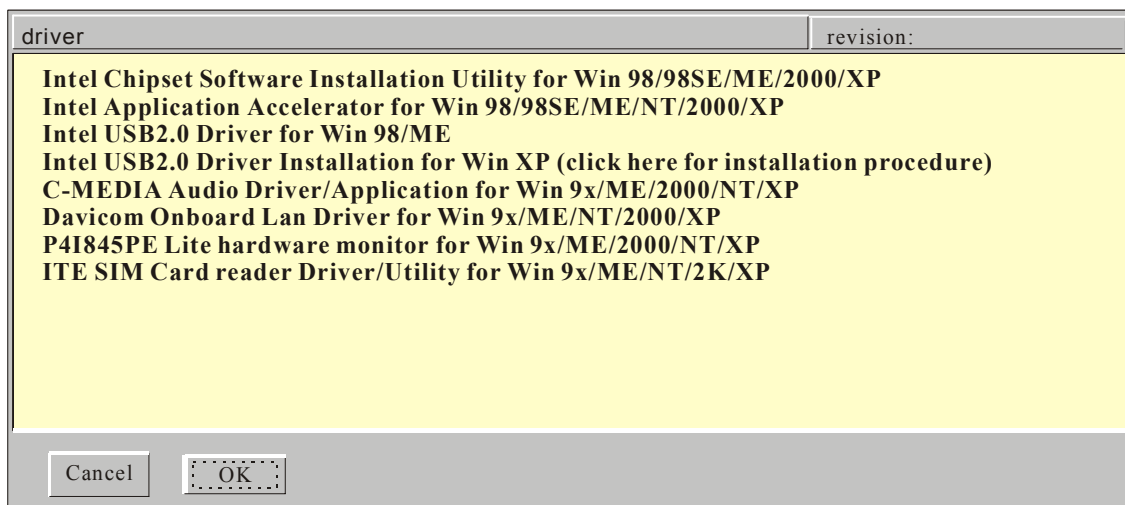

(Driver Installation Menu)

### A short description of all available drivers follows:

➤ **Intel Chipset Software Installation Utility for Win 98/98SE/ME/2000/XP**

Windows 95 and 98 will not recognize the new INTEL 845PE chipset properly. To update the necessary .inf files that will help Windows recognize the 845PE chipset, please run this utility.

➤ **Intel Application Accelerator for Win 98/98SE/ME/NT/2000/XP**

The Intel(R) Application Accelerator is designed to improve performance of the IDE sub-system and overall system performance. Several components will be available only on Pentium(R) 4 processor-based systems running Microsoft Windows 2000 Professional. Software installation is flexible and fully automated for Microsoft Windows 98, Windows 98 Second Edition(SE), Windows 98 Millennium Edition(Me), Windows NT 4.0, and Windows 2000 operating systems.

➤ **Intel USB2.0 Driver for Win98/ME**

This setup program will install the driver for Intel USB2.0 Host Controller. If you don't, your USB controller only works with USB1.1 devices.

➤ **C-MEDIA Audio Driver/Application for Win 9x/ME/2000/NT/XP**

1. The driver supports 2/4 speakers 3D positional audio.
2. The application includes the **CD Player/MIDI Player/MP3/Wave Player/Mixer** to control your PC's audio functions.

## **SY-P4I845PE Lite Quick Start Guide**

---

➤ **Davicom Onboard Lan Driver for Win 9x/ME/NT/2000/XP**

This Setup program will install the Driver for Davicom Onboard Lan.

➤ **P4I845PE Lite ITE hardware doctor for Win 9x/ME/2000/NT/XP**

Your motherboard comes with a hardware monitoring IC. By installing this utility Temperature, Fan speed and Voltages can be monitored.

➤ **ITE SIM card reader Driver/Utility for Win 9X/ME/NT/2K/XP**

Driver to support the smart card reader. You need to install this if you use the SCR.

Select which driver you want to install and click **OK**, or click **Cancel** to abort the driver installation and return to the main menu.

**Note :** Once you have selected a driver, the system will automatically exit the SOYO CD to begin the driver installation program. When the installation is complete, most drivers require restart or your system before they become active.

### **Step 3. Check the Latest Releases**

Click the 'Connect to SOYO website' button to go the SOYO Website to find the latest BIOS, manual and driver releases for your motherboard. This button will only work if your computer is connected to the internet through a network or modem connection.

Make sure to get your internet connection up before clicking this button.

## SY-P4I845PE Lite Quick Start Guide

After Windows XP installation, your device manager should look like this:

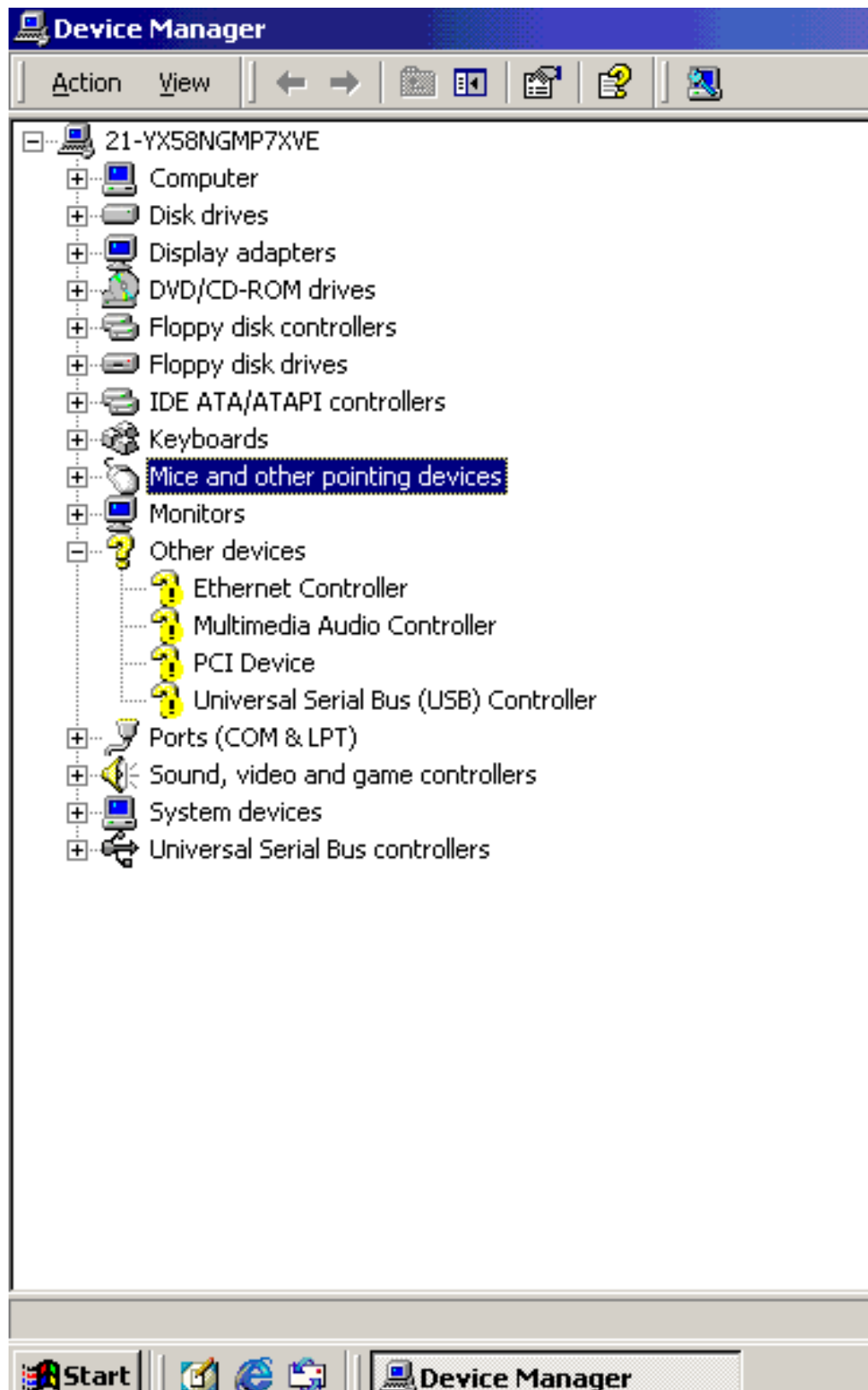

## SY-P4I845PE Lite *Quick Start Guide*

After driver installation, your Windows XP device manager should look like this:

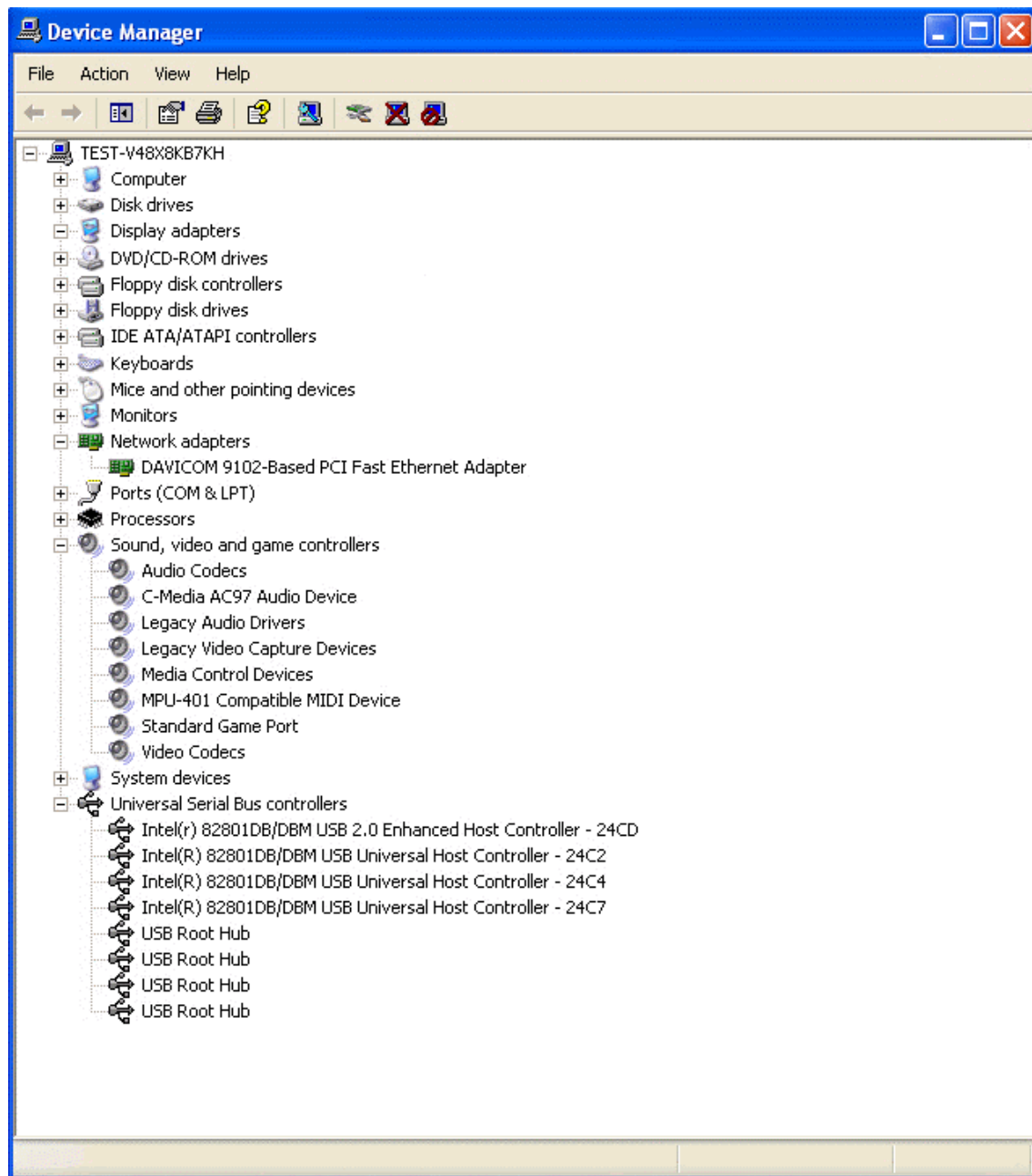

Note: To install the USB 2.0 driver, please update to Windows XP service pack 1

Drivers directory list in the CD driver

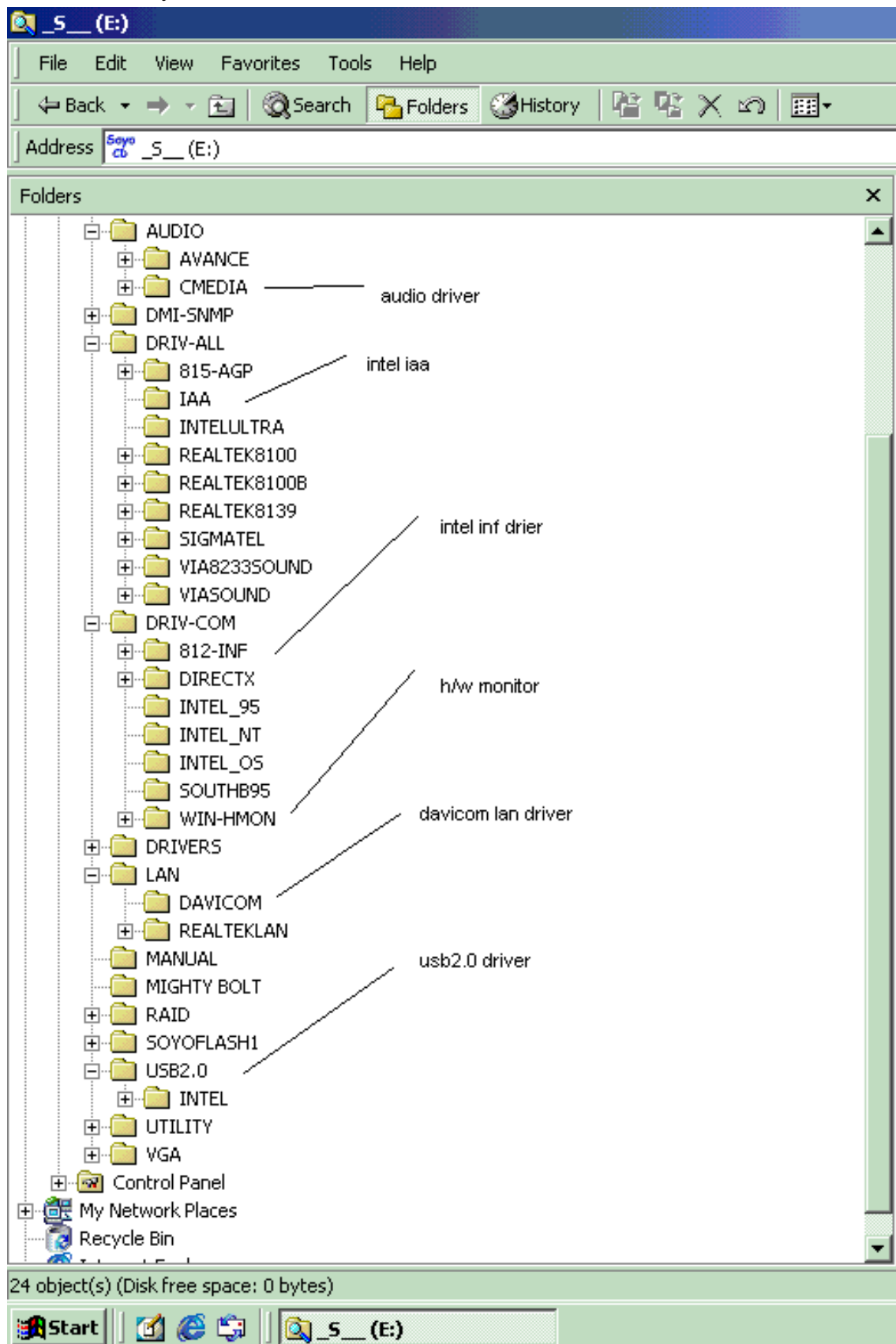

The SOYO CD

## **5 USB2.0 Driver Installation**

### **For Windows 2000 and Windows XP**

USB 2.0 Drivers are available for download using Windows Update for both Windows XP and Windows 2000.

For additional information regarding USB 2.0 support in Windows XP and Windows 2000, please visit <http://www.microsoft.com/hwdev/bus/USB/default.asp>



## **Quick Trouble shoot tips**

### **Boot-up Issues**

**The system do not power-up, no beeping sound heard and the CPU fan does not turn on.**

1. Check if the power cord is plug to the power source.
2. Check if the power is connected to the M/B.
3. Check if the cable of the case power button is connected to the M/B power button connector (see connectors and plug-ins in the manual for more info).
4. Make sure the power supply is not defective. Change the power supply. The minimum should be 250 watts.
5. Remove the M/B from the case and test the system. The M/B might be shorted to the case.

**The system power-up, no video, no beeping sound heard, but the CPU fan is turning.**

1. Clear CMOS battery. (JP5 connector, see Quick start guide for more info on how to clear the CMOS).
2. Check all the jumper settings on the M/B. (if the M/B have any).
3. Check if the CPU is ok by using another CPU (check the Quick start guide for CPU supported on this M/B).
4. Check if the power supply is ok. The minimum should be 250 watts.
5. Make sure the CPU fan is connected to CPUFAN1 connector.
6. Remove the M/B from the case and test the system. The M/B might be shorted to the case.
7. Change the VGA card. If you have used a 3.3V AGP card, the M/B might be damage.

**The system power-up, no video, beeping heard.**

1. Clear CMOS battery. (JP5 connector, see Quick start guide for more info on how to clear the CMOS).
2. Check all the jumper settings on the M/B. (if the M/B have any).
3. Check the memory module and the VGA card if inserted properly on the M/B.
4. If yes, change the memory module, it might be defective. Make sure the memory specification is supported by the M/B. (for more info on this, check our FAQ website).
5. Change the VGA card. Make sure the AGP card is 1.5v

**The system turns on for some seconds then shutdown by itself.**

1. Check if the CPU fan is connected to the CPUFAN1 connector.

## **SY-P4I845PE Lite Quick Start Guide**

---

2. The CPU might be overheating. Check the CPU FAN if it is defective or see if the CPU fan is in contact with the CPU.
3. Clear CMOS battery. (JP5 connector, see Quick start guide for more info on how to clear the CMOS).
4. Make sure the power supply you have on your system support the M/B specification. Example. If you have a P4 M/B, you need to use a P4 power supply.
5. If you already checked the power supply specification, change the power supply it might be defective. The minimum is 250 watts.

**When I boot up my system, everything works fine, it sees my CPU and memory, detects my hard drive, floppy drive and CD-ROM but locks up at "Verify DMI pool data... ". Don't go any further. What should I do?**

1. Clear CMOS battery. (JP5 connector, see Quick start guide for more info on how to clear the CMOS).
2. If still has the problem, remove all other add-on cards except video card see if it move further. Then put peripherals in one by one to identify which one cause the lockup.
3. Change the CPU.

**During Boot-up, my computer says CMOS memory Checksum error. What is the problem?**

1. Clear CMOS memory.
2. Re-flash BIOS. Check on how to flash BIOS on the later part of this book.
3. Change the CMOS battery, the battery might be drained.
4. The BIOS chip might be failing.

## **Stability Issue**

**My system intermittently locks up, very unstable**

1. Check the CPU Temp, it might be overheating. Change the CPU FAN.
2. Do not over clock your CPU
3. Check the specification of the memory module, maybe the M/B do not support it.
4. Go to BIOS setup and load fail safe settings. Please check if the system performance in the BIOS setup is set to Turbo/Maximum.
5. Check website for latest BIOS update.
6. Check website for FAQ's regarding instability issue.
7. Change the memory module or CPU.
8. The power supply might not have enough wattage to support all the peripherals. If your system has other peripherals connected, like CD-RW, extra HDD, etc. disconnect them.
9. Install Intel Inf driver.

### **My system intermittently locks up, during Windows installation.**

1. Go to BIOS and load "load optimized default".
2. Check website for any BIOS update.
3. If still has the problem, remove all other add-on cards except CPU/ Memory/ Video card/Hard disk. See if you can finish Windows installation. Then put peripherals in one by one to identify which one cause the lockup.

## **BIOS Issue**

### **Where can I find the BIOS revision of my mainboard?**

It will be displayed on the up-left corner on the screen during boot-up. It will show as your board type followed by the revision number, such as kvxa\_2BA1 (meaning BIOS revision 2BA1 for the SY-K7V Dragon plus! board) or 6BA+ IV\_2AA2 which means SY-6BA+ IV motherboard with 2AA2 BIOS.

### **Where can I find the latest BIOS of my motherboard?**

Please go to the technical support page of one of the SOYO websites (Taiwan: [www.soyo.com.tw](http://www.soyo.com.tw)), and look up your motherboard to find the latest BIOS revision.

### **How can I flash the BIOS?**

1. Download the BIOS on our support website.
2. Make a bootable floppy disk with out any memory manager loaded (i.e. himem, emm386, etc...).
3. Copy the BIOS file and awdf flash utility to the diskette.
4. Type "awdf flash biosname.bin /sn /py".
5. Then reboot.

### **After flashing the BIOS, my system will not boot-up.**

1. Try clearing the CMOS.
2. The BIOS chip is defected due to unsuccessful flash, contact your nearest SOYO branch for re-flashing.

### **Is there a way to reprogram my BIOS after an unsuccessful flash?**

No other way, you need to send back the BIOS ROM to your nearest SOYO branch for re-flashing.

## **SY-P4I845PE Lite Quick Start Guide**

---

**I'm using a 400MHz FSB CPU, I cannot find the DDR 166MHz option in the BIOS, why?**

The CPU used should be 133MHz FSB to have PC2700 support.

### **VGA Issue**

**I cannot set my VGA to go higher than 16 color (640x 480).**

1. Make sure that you have installed the Intel Inf driver.
2. Install/ re-install the VGA driver.

**After wake-up from Suspend to RAM or Standby mode, the screen has no display but I can hear the hard disk operating**

1. Check the VGA card manufacturer for driver update, or make sure the VGA card support Suspend to Ram function.

### **Audio Issue**

**How can I disable the on-board Audio?**

Go to the SOYO Combo Feature in the BIOS setup, then set the "onboard audio" to disable.

**I cannot get the sound working on my system.**

1. Check if the speaker wire is connected to the line out connector in the M/B.
2. Check if the speaker power is powered on.
3. Install the audio driver supplied on our driver disc.
4. Check BIOS setup if "onboard audio" is enabled.
5. If sound already installed, check our website for audio driver update.

**The sound is working in my system, but when I play CD music from the CD-ROM, I do not get any sound. What is wrong?**

This is because the 3-wire audio cable from the CD-ROM to the on-board CDIN1 connector in the M/B is not connected. See manual for location of CDIN1.

**The sound and everything else works fine except that the recorder and microphone do not work. What is wrong?**

1. Please go to sound properties and check if the recorder and microphone in the are enabled.
2. Check if Microphone is ok.

**Add PCI Audio Card do not work on this motherboard.**

1. Go to SOYO COMBO Setup and Disable "onboard audio".
2. Go to integrated peripherals and Disable "Game port address" and "Midi port address"

**Hard disk/FDD/ CD-ROM issue**

**My Western digital HDD is not detected during boot-up**

Change the jumper settings to cable select or single.

**Sometimes the system finds my CD-ROM, sometimes not**

1. Check CD-ROM if it is working properly.
2. The power supply might not have enough wattage to support all the peripherals. If your system has other peripherals connected, like CD-RW, extra HDD, etc. disconnect them.

**When I boot up my new computer I got "floppy boot failure" and the LED on the floppy stays on**

Make sure the red wire of floppy ribbon cable goes to Pin1 on the floppy drive side (don't trust the "key lock" or "notch") and use the end-connector of the cable (don't use middle one).

**LAN Issues**

**During LAN driver installation, the system hangs on 75%, why?**

Enable the onboard LAN in the BIOS setup.

**I have problem installing Novell NetWare v.50**

Disable the APIC option in the BIOS.

For updated FAQs, please check <http://www.soyo.com.tw/faq.htm> or <http://www.soyousa.com/faqs.html>

## **SY-P4I845PE Lite Quick Start Guide**

---

### **How to contact us:**

- If you are interested in our products, please contact the SOYO sales department in the region you live.
- If you require Technical Assistance, please contact our Technical Support in the region you live.

SOYO prefers Email as communication medium, remember to *always add to the email the country that you live in.*

### **TAIWAN**

SOYO COMPUTER INC.

---

No. 21 Wu-Kung 5 Rd., Hsin Chuang  
City, Taipei Hsien, Taiwan, R.O.C

---

TEL: 886-2-22903300

FAX: 886-2-22983322

<http://www.soyo.com/>

Email: [info@mail.soyo.com.tw](mailto:info@mail.soyo.com.tw)

### **Hong Kong**

SOYO ASIA LTD.

---

5C, Big Star Centre, 8 Wang Kwong  
Road, Kowloon Bay, Kowloon, HK

---

TEL: 852-2710-9810

FAX: 852-2710-9078

<http://www.soyo.com.hk/>

Email: [soyo@hkstar.com](mailto:soyo@hkstar.com)

### **USA**

SOYO INC.

---

41484 Christy Street, Fremont, CA  
94538, USA

---

TEL: 1-510-226-7696

FAX: 1-510-226-9218

<http://www.soyousa.com/>

<http://www.soyousa.com/kb>

Email : [support@soyousa.com](mailto:support@soyousa.com)

### **GM**

SOYO Deutschland GmbH  
(SAAT Technology GmbH)

---

August-Wilhelm-Kuhnholz-Str. 15  
D-26135 Oldenburg (Oldb), Germany

---

TEL: 49-441-209-100

FAX: 49-441-203-442

<http://www.soyo.de/>

Email: [sales@soyo.de](mailto:sales@soyo.de)



**Edition : February 2003**  
**Version 1.2**  
**SY-P4I845PE Lite**  
**SERIAL**

