

# SUNPENTOWN

Portable Air Conditioner / Heater

## Your Guarantee

If this product is found to be faulty as a result of faulty materials or workmanship within one year from date of purchase, it will be repaired or replaced free of charge.

This guarantee is subject to the following terms:

SUNPENTOWN, must be notified of the fault.

Proof of purchase must be presented to SUNPENTOWN's nominated representative.

The warranty will be void if the product is modified, misused or repaired by an unauthorized person.

The guarantee after repair or replacement will not be extended beyond the original one year period.

All replacement parts or units will be new or reconditioned.

Parts or units, which are replaced, become the property of SUNPENTOWN.

The warranty applies to the use of this product in the United States.

Warranty does not include freight charges.

**This GUARANTEE is in addition to your Statutory Rights.**

Dear Customer: Please keep this warranty for your record. **DO NOT** return it.

# SUNPENTOWN

## Instruction Manual

For models WA-1010E, WA-1010H, WA-1010M

# PORTABLE Air Conditioner



It is important that you read these instructions before using your new purchase and we strongly recommend that you keep them in a safe place for future reference.

## Maintenance

Always unplug the unit from the mains before beginning the cleaning.

### Cleaning the Housing

Use a soft, damp cloth to wipe the body clean.

Never use strong chemicals, oil-based products, detergents, chemically treated cloths or other cleaning solutions. These could possibly damage the cabinet.

### Cleaning the Filter

Use a vacuum cleaner or tap the filter lightly to remove loose dust and dirt from the filters and then rinse them thoroughly under running water (no hotter than 104°F).

Dry thoroughly before replacing.

Do not wet the activated carbon filter, remove from frame before rinsing.

*Notice! Never operate the unit without the filters.*

### End of Season Storage

Unplug the unit.

Drain the condensed water COMPLETELY (please refer to page 11).

Clean or change the filter.

On a warm day, turn the unit to fan mode for a couple of hours so that the inside can dry out completely.

It is recommended that the unit be put back into its original carton for storage.

Do not stack heavy objects on top of the unit.

### Storing the Power Cord

When the unit is not in use, please store the power cord away as shown in Figure 3.

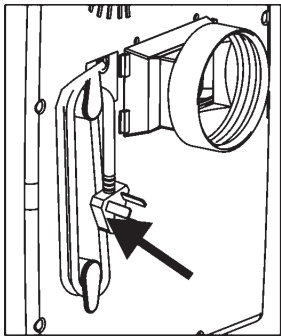

Fig. 3

## Thank You!

Thank you for choosing the portable air conditioner from SUNPENTOWN, a leading brand in indoor air treatment. We would like you to enjoy the many benefits this unit offers, so please take the time to read this manual carefully and take full advantage of the many advanced features that your SUNPENTOWN Air Conditioner offers you.

SUNPENTOWN has specialized in complete indoor environment control, manufacturing world-class air conditioners, dehumidifiers and air purifiers with innovative technology.

In designing these advanced products, we have listened carefully to our customers and have passed their views on to our research and development laboratories.

We wish you many years of enjoyable use.

After reading this manual, please keep it in a safe place for future reference.

### Energy Saving Tips

- Please use the unit in the recommended room size. (Refer to SPECIFICATIONS).
- Do not locate the air conditioner where furniture or other objects can obstruct the airflow.
- Keep blinds/curtains closed during the sunniest part of the day.
- Close the fireplace damper and floor or wall grills so that cool air does not escape through the chimney or ductwork.
- Keep the filters clean.

Set the unit to maximum cooling and high speed fan initially, then adjust the unit to a comfortable setting.

NOTE: It is recommended to turn on the air conditioner when the room temperature is around 75°F. Do not wait until the room is excessively hot.

## Operation - Mechanical Models

### Setting the Temperature

Turn the THERMOSTAT to regulate the temperature you desire: range 64°F to 90°F.

### Setting the Timer

Set the TIMER to the desired operating time (1 to 8 hours).

When the set time has elapsed, the machine will shut off automatically.

### Regulating the Airflow Direction

Turn the roller on the air vent to control the airflow direction from the vertical louvres.

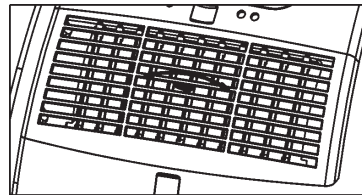

### NOTICE!

- **The compressor will start approximately 3 minutes after the unit is turned on (this will help prolong the life of the compressor). After switching the unit off, please wait at least 3 minutes before turning the unit back on.**
- The cooling system will switch off if the room temperature is lower than set. The fan, however, keeps working at the set level. If the ambient temperature rises above the chosen level, the cooling will resume.

## Before Use

### Important!

- Transport the unit in an upright position only, or leave it in an upright position for at least 2 hours before first use.
- Always place the unit on an even surface (Figure 1).
- Make sure the unit is connected to a correctly grounded power supply (refer to the rating label located at the back of the unit).
- An opening in a window or wall is required to accommodate the exhaust hose (kit supplied) to expel the warm air.
- Do not cover or obstruct the appliance inlet or outlet grilles (Figure 2).
- To avoid the risk of shock, the product should never be used in bathrooms, shower rooms or in any other steamy or wet areas.
- The unit will cool when the room temperature is between 64°F and 110°F depending on the thermostat setting.
- Do not sit or place objects on the unit.
- Do not touch the unit with wet/damp hands or when standing barefoot.
- Avoid all contact with chemical based materials.
- The filter must be used with the product at all times. When removing for cleaning, always disconnect the unit from the mains first.
- Turn off the appliance when not in use.
- At the end of each season all water must be drained and the unit and filters cleaned before storage.
- **Drainage of the water container is required before moving the unit or putting it into storage.**
- If the electric socket is different from the plug provided, have a professionally qualified electrician replace the plug with a suitable one. Avoid the use of adaptor plugs, multiple sockets and/or extension leads; if their use is necessary, ensure that they conform to the current safety regulations.
- Do not pull the supply cable or place it near a source of heat; always unroll it completely to avoid the possibility of dangerous overheating.
- If the supply cord is damaged, it must be replaced by the service agent or a similarly qualified person.

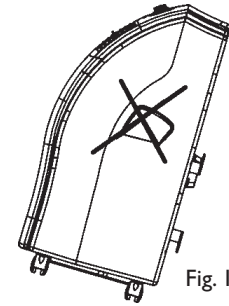

Fig. 1

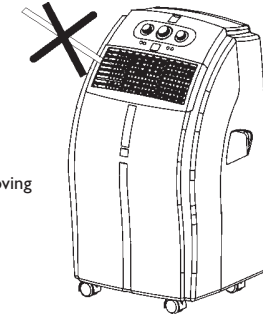

Fig. 2

THE MANUFACTURER DISCLAIMS ANY RESPONSIBILITY IF THE ABOVE INSTRUCTIONS ARE NOT FOLLOWED.

## Operation - Electronic Control Models

### Setting The Fan Speed

Press the SPEED button to choose the fan speed you require, high or low. The indicator of high or low fan will light up at the same time.

If the unit is in AUTO mode, it will select the fan speed automatically according to the ambient temperature (the related indicators, cool, fan or heat will light up), at this time the fan speed switch is invalid.

### Setting the Timer

Press the TIMER button to set the operating hours you desire (1 to 12 hours, the timer indicator will light up). When the set time has elapsed, the machine will turn off automatically. The display window will show the hour(s) you set as you press the TIMER button. If the timer button is not pressed, the unit will work continuously.

By pressing the timer button but without turning on the unit, you can PRE-SET the time for the machine to work. For example, if you press the timer to '2', the unit will come on automatically after 2 hours.

All the above functions can also be performed with the supplied remote control. This remote control requires 2 AAA batteries to operate.



### Regulating the airflow direction

Turn the roller on the air vent to control the airflow direction from the vertical louvers.

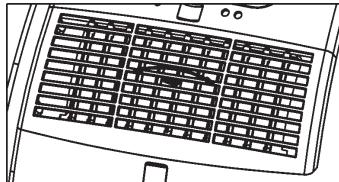

### Notice!

- To prolong the unit's life, it will start 3 minutes after the unit was switched on. After switching off, please wait at least 3 minutes before switching it on again.
- The cooling system will switch off if the room temperature is lower than set. The fan, however, keeps working at the set level. If the ambient temperature rises above the chosen temperature +5°F, the cooling will resume.
- In heating mode, the compressor will switch off if the room temperature is HIGHER than the set one (still, the fan keeps working at the set level). As the room temperature drops below the selected level -5°, the heating will resume.
- This machine is equipped with an ANTI-FROST function. While using the heating function during low temperatures, sometimes the heating will stop for a while in order to melt the internal frost. When this occurs just wait for heating to resume.
- As you switch on the heating, the fan will stop for 15-20 seconds first for warm up purposes.

## Installation

### Mounting the unit

This unit is a portable air conditioner. It can be moved from room to room so that the cooling can follow you anywhere. Fitting the exhaust hose is easy, through a window or wall. Please refer to either of the following ways:

#### 1. Using the foam strips

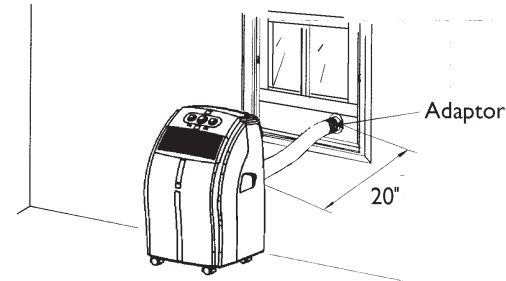

- Connect the supplied foam strips with the exhaust pipe, let the hot air flow to the outside.
- Should the foam strip(s) be too large, cut off the extra part to fit the window.

#### 2. Using the Through the Wall Connection

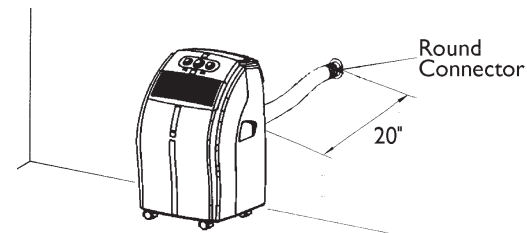

- Make a hole ( $4\frac{3}{8}$ " in diameter) in the wall to fit the supplied round connector.
- Fit the hose directly to the round connector.
- When the hole is not in use, use the cap for the round connector to cover the hole.

## Installation

### Mounting the exhaust pipe

- The supplied exhaust hose can be extended from 1 foot to 5 feet for mounting. It is recommended that you use the shortest possible length of hose.
- Take care to prevent any kink or bend in the middle of the exhaust hose, as this will trap hot exhaust air, which will radiate back into the room.

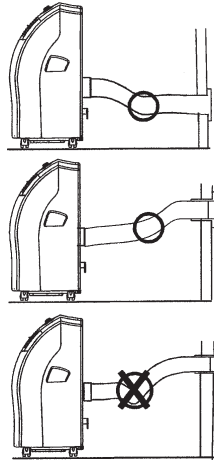

### WARNING!

The length of the exhaust pipe is specially designed according to the specification of this product.

Do not replace or extend it with your own hose as this could cause the unit to malfunction.

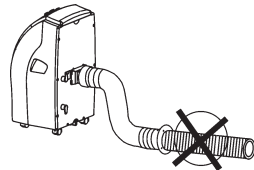

### Installation of the Carbon Filter

- Remove the filter frame from the unit.
- Separate the filter from the filter frame.
- Remove the active carbon filter from its plastic bag.
- Insert the active carbon filter into the filter frame.
- Fix the filter by reassembling the fixer onto the filter frame.
- Re-fit the filter frame inside the unit.
- It is recommended to replace the carbon filter every 3 to 6 months.

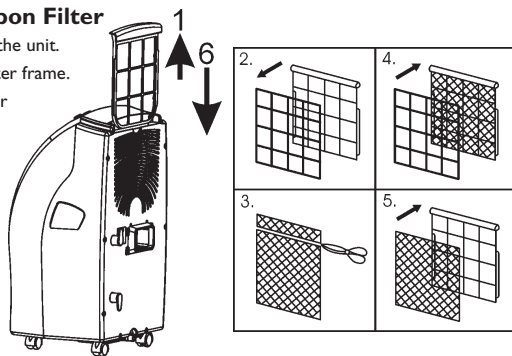

6

## Operation - Electronic Control Models

### Control Panel

- 
- Automatic mode indicator
  - Cooling mode indicator
  - Fan mode indicator
  - Heating mode indicator (For VVA-1010H)
  - Compressor operation indicator
  - 'Set temperature' indicator
  - 'Room temperature' indicator
  - Timer operation indicator
  - Low ventilation indicator
  - High ventilation indicator
  - ON/OFF (power) button
  - Speed (ventilation) button
  - Timer button
  - Receiver for Remote Control
  - 'Temperature Down' button
  - 'Temperature Up' button
  - Display window
  - Mode (function) option button

### Turning ON/OFF

Press the ON/OFF selector; the unit will start to work at its last setting.

### Setting Mode/Function

Press the MODE button to select the required working mode: Automatic, Cooling, Fan or Heating (Heating is only available for WA-1010H). The green indicator illustrating your selected mode lights up. It is recommended to select Cooling or Heating mode and set your desired temperature, as the Auto mode has a preset temperature (please see below) that cannot be changed.

The indicators of the functions in progress come on at the same time, e.g. Cool and Lo = Cooling mode with Low fan speed.

### Auto Mode

When this mode is selected, the unit is preset to the following temperature settings and unit will only start to:

- Cool when room temperature is higher than 75°F
- Heat when room temperature is higher than 68°F (WA-1010H only)

If room temperature is between 68°F and 75°F, unit will stay in Fan mode. Again, when in Auto Mode, the temperature settings cannot be changed.

### Setting the Temperature in Cooling or Heating Mode

The display window's default is to display the ambient room temperature. The green indicator light under RT is on. (RT = Room Temperature)

To set your desired temperature, press the Temperature Up or Down buttons (ranging from 64°F to 90°F). Each press will increase or decrease your set temperature by 1°F. When pressing the temperature up or down buttons, the window will change to display your set temperature. At this time, the green indicator will light under ST (Set Temperature). Once the temperature up or down buttons is released, the window will return to displaying the ambient temperature after a second.

**Note:** When unit is in the following modes: Auto, Cool, or Heat - the compressor will cool/heat the room to reach the set temperature. Once the ambient temperature has reached the set temperature, the compressor will stop and unit will run in Fan mode. To conserve energy, the compressor will not start immediately after a couple degrees increase or decrease, but will wait for a 5°F allowance. For example:

#### In Cooling Mode with a set temperature of 70°F

When compressor first stops after reaching 70°F, unit will auto-switch to Fan. Compressor will start cooling again when ambient temperature increases to 75°F or above.

#### In Heating Mode with a set temperature of 72°F

When compressor first stops after reaching 72°F, unit will auto-switch to Fan. Compressor will start heating again when ambient temperature drops to 67°F or below.

#### In Auto Mode (with preset temperature of 68°F for heat and 75°F for cool)

Compressor will start cooling again when ambient temperature reaches above 80°F or will start heating when ambient temperature drops below 63°F.

7

## Parts

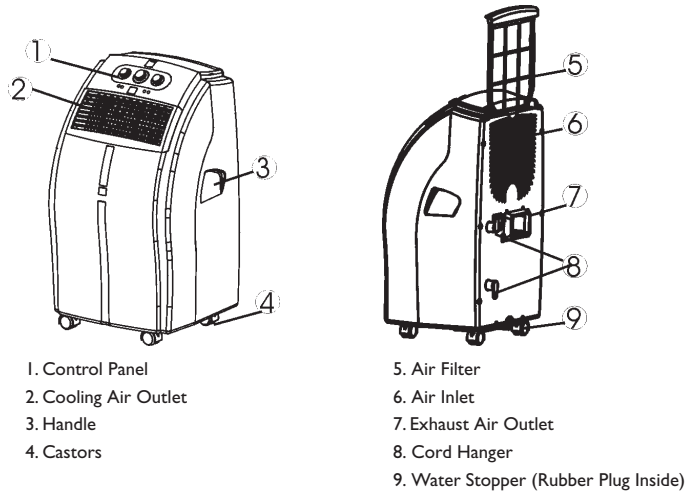

1. Control Panel
2. Cooling Air Outlet
3. Handle
4. Castors
5. Air Filter
6. Air Inlet
7. Exhaust Air Outlet
8. Cord Hanger
9. Water Stopper (Rubber Plug Inside)

## Accessories

10. Adaptor - for insertion over the hose and into the back of the air conditioner.
11. Exhaust Hose
12. Foam Strip - for filling the open window space and with a hole for connection to the exhaust hose.
13. Foam Strip - for filling the open window space.
14. Round Connector - to be used between hose and window kit or between hose and wall.
15. Cap for Round Connector
16. Remote Control (Electronic control models only)

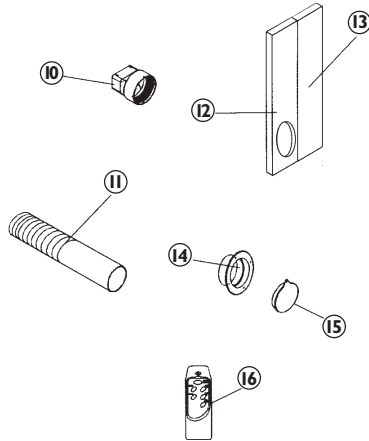

## Operation - Mechanical Models

1. Power indicator
2. Fan operating indicator
3. Cooling operating indicator
4. Full water indicator
5. Thermostat
6. Speed switch with options for:  
LOW FAN, HIGH FAN, LOW COOL,  
HIGH COOL
7. Timer (1-8 hours) as well as  
ON/OFF switch

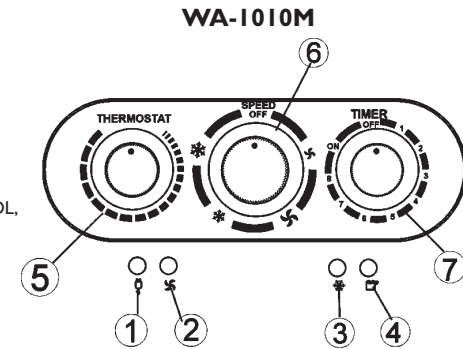

### Turning ON/OFF

Set **TIMER** to **ON** for continuous operation (the unit will operate as long as it is not turned off). Power indicator comes on.

To turn off the unit, turn the **TIMER** to the **OFF** position

### Setting Function / Ventilation Speed

#### WA-1010M

Turn the speed switch to select the required setting:  
LOW FAN, HIGH FAN, LOW COOL, HIGH COOL  
SPEED OFF

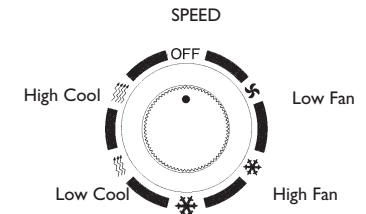

## Specifications

Model Number	WA-1010E WA-1010M	WA-1010H
Cooling Capacity	10,000 BTU/hr	10,000 BTU/hr
Heating Capacity (1)(2)	N/A	10,000 BTU/hr
Power Consumption	660W / 6.3A	660W / 6.3A
Humidity Removal Capacity	50 Pts./day	50 Pts./day
Recommended Room Size*	300 sq. ft.	300 sq. ft.
Power Supply	120V / 60Hz / 1 Phase	120V / 60Hz / 1 Phase
Compressor	Rotary	Rotary
Refrigerant	R-22	R-22
Fan Speed	2	2
Timer	WA-1010E: 1-12 hours WA-1010M: 1-8 hours	1-12 hours
Thermostat	64°F - 90°F	64°F - 90°F
Net Weight	65 lbs.	68 lbs.
Dimensions	17"W x 17"D x 30"H	15"W x 16"D x 30"H
Working Temperature	Cooling: 64°F to 110°F	Cooling: 64°F to 110°F Heating: 41°F to 81°F

### REMARKS:

- The data may vary, please refer to the rating label on the back of the unit.
  - The above conditions are measured at:  
Cooling - Indoor: RT 81°F, RH 60%  
Heating - Indoor: RT 68°F, RH 60%
- \* Uninsulated rooms such as sunrooms, garages, or attics should be less than 300 sq. ft.

## Drainage

During the process of cooling, some water will be extracted from the air into the unit. Most of this water is used to cool the unit and make it run more efficiently. This is a feature not found in most Portable Air Conditioners. If the unit is operated in VERY HUMID air, water will collect in the container inside the unit. If the water container is full, the compressor will stop, but the fan will continue to circulate the air. The POWER indicator will blink to inform you to empty the internal container. To make the cooling function work again, please empty the water by one of the following methods:

### By the Draining into a Container

Use a Shallow Container or Dish

- Turn off the unit.
- Position a flat container or dish under the drain hole. Do not allow the water to drip continuously into the container, as it might easily overflow.
- Remove the drain knob & rubber plug from the drain hole. The condensed water will drain out automatically.
- When the container is almost full, replace the rubber plug into the drain hole to stop the water. Empty the container.
- Repeat steps 2, 3 & 4 until all the condensed water is emptied.
- Once all the condensed water has been removed, replace the rubber plug into the drain hole firmly. The Full Water indicator should be off now.
- Replace the drain knob.

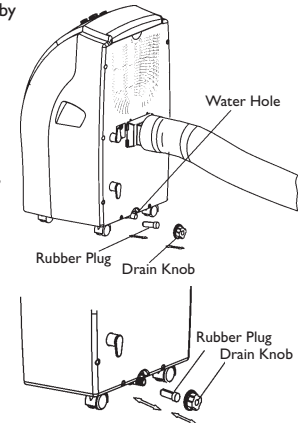

### By Water Tube (Continuous Drainage)

- Remove the drain knob and rubber plug and keep them for future use.
- Connect a suitable water tube (of 3/4" internal diameter - supplied) to the water hole. The condensed water will drain out automatically.
- If you want to extend the water tube you can connect it with another tube (outside diameter 3/4").

### Special Caution for Heating Function!

While using the heating function, please note:

- Install the exhaust pipe securely in order to exhaust the cool air to the outside (please see page 6).
- Use the continuous drainage option as described above.
- The warmer the outside air the more heat will be pumped into the room. Working range for heat pump function is 41°F to 81°F. When used in room temperatures outside this range the unit may not function properly.
- While using the heating function during low temperatures, sometimes the heating will stop for awhile in order to melt the internal frost. When this occurs, just wait for heating to resume. This is normal for compressor operated devices.

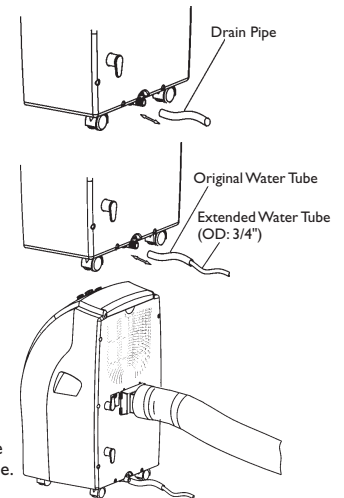

## Table of Contents

THANK YOU.....	1
<i>Energy Saving Tips</i> .....	1
SPECIFICATIONS .....	2
BEFORE USE.....	3
PARTS .....	4
<i>Accessories</i> .....	4
INSTALLATION .....	5
<i>Mounting the Unit</i> .....	5
<i>Mounting the Exhaust Pipe</i> .....	6
<i>Installation of the Carbon Filter</i> .....	6
OPERATION - ELECTRONIC CONTROL MODELS .....	7
<i>Control Panel</i> .....	7
<i>Turning On/Off</i> .....	7
<i>Setting Mode / Function</i> .....	7
<i>Auto Mode</i> .....	7
<i>Setting the Temperature</i> .....	7
<i>Setting Fan Speed</i> .....	8
<i>Setting the Timer</i> .....	8
<i>Regulating Airflow Direction</i> .....	8
OPERATION - MECHANICAL CONTROL MODELS .....	9
<i>Turning On/Off</i> .....	9
<i>Setting Function / Ventilation Speed</i> .....	9
<i>Setting the Temperature</i> .....	10
<i>Setting the Timer</i> .....	10
<i>Regulating the Airflow Direction</i> .....	10
DRAINAGE.....	11
<i>By the Draining into a Container</i> .....	11
<i>By Water Tube (continuous drainage)</i> .....	11
MAINTENANCE .....	12
<i>Cleaning the Housing</i> .....	12
<i>Cleaning the Filter</i> .....	12
<i>End of Season Storage</i> .....	12
<i>Storing the Power Cord</i> .....	12
TROUBLESHOOTING.....	13
YOUR GUARANTEE.....	14

## Troubleshooting

### The unit doesn't run or only runs in fan mode

- Is the machine plugged in?
- Is the mains power supply on?
- Is the room temperature in the working range?
- Is the unit in cooling mode or heating mode rather than auto mode when it will work according to its own settings?

### The unit seems to do little

- Is there direct sunshine? (Please close the curtains or blinds)
- Are too many windows or doors open?
- Are there too many people in the room?
- Is there something in the room producing lots of heat?

### The unit seems to do nothing

- Is the dust filter dirty?
- Is the air intake or outlet blocked up?
- Is the room temperature within the selected temperature +/- 5°F?

### The room is not cold enough

- The room being cooled should have proper insulation. If the unit is used in UN-INSULATED rooms such as Sunrooms, Garages, or Attics, ideal cooling might not be attained.

### Too noisy

- Is the machine positioned unevenly so as to create vibration?
- Is the floor underneath the machine uneven?

### The compressor doesn't run

- The overheat protection feature on the compressor might be on. If this occurs, wait for the temperature of the unit to drop.
- Is the water container full? Does it need draining?

### NEVER TRY TO REPAIR OR DISMANTLE THE UNIT YOURSELF

#### REPLACEMENT FILTERS:

To purchase Replacement Filters for this unit, contact **SUNPENTOWN** at **1-800-330-0388** and request model number **WA-1010F**.

If this product is defective or not working properly,  
**please DO NOT return to your retail store.**  
 Please contact us directly for any Service or Technical Assistance at 1-800-330-0388.