

Seagate

Cheetah 10K.6 FC Installation Guide

ST3146807FC, ST373307FC, ST336607FC

Publication Number: 100195492, Rev. B, June 2002

Handling precautions/Electrostatic discharge protection

- Disc drives are fragile. Do not drop or jar the drive. Handle the drive only by the edges or frame.
- Drive electronics are extremely sensitive to static electricity. Keep the drive in its antistatic container until you are ready to install it. Wear a wrist strap and cable connected to ground. Discharge static from all items near or that will contact the drive. Never use an ohmmeter on any circuit boards.
- Turn off the power to the host system during installation.
- Always use forced-air ventilation when operating the drive.
- Use caution when troubleshooting a unit that has voltages present.
- Do not disassemble the drive; doing so voids the warranty.
- Return the entire drive for depot service if any part is defective.
- Do not apply pressure or attach labels to the circuit board or to the top of the drive.

Electromagnetic compliance

See the Safety and Regulatory Agency Specifications page, part number 75789512 which was shipped with this installation guide.

Drive characteristics

	ST3146807FC	ST373307FC	ST336607FC
Formatted capacity	146.80 Gbytes	73.40 Gbytes	36.70 Gbytes
Total # of data blocks	286,749,488 (11177330h)	143,374,744 (88BB998h)	71,687,372 (445DCCCh)
Cylinders (user accessible)	49,855	49,855	49,855
Heads (user accessible)	8	4	2
Disc rotation +/- 5%	10,008 RPM	10,008 RPM	10,008 RPM
Operating voltages	+5V +12V	+5V +12V	+5V +12V
Typical operating current (amps)	0.97 0.94	0.97 0.88	0.99 0.75

What you need

- Screwdriver and four 6-32 UNC drive mounting screws
- Forced-air ventilation to provide adequate drive cooling
- Host system with Fibre Channel host adapter or backplane

Installation instructions

1. Mount the drive in the host system carrier or tray

Most Fibre Channel host systems (including enclosures) provide a way to insert the drive using a carrier or tray which allows the drive to be hot-plugged into the system's Fibre Channel 40-pin single connector attachment (FC-SCA).

Mount the drive to the carrier or tray provided by the host system using four 6-32 UNC screws. Do not over-tighten or force the screws. You can mount the drive in any orientation. See Figure 1.

Note. FC drives are designed to be attached to the host system without I/O or power cables.

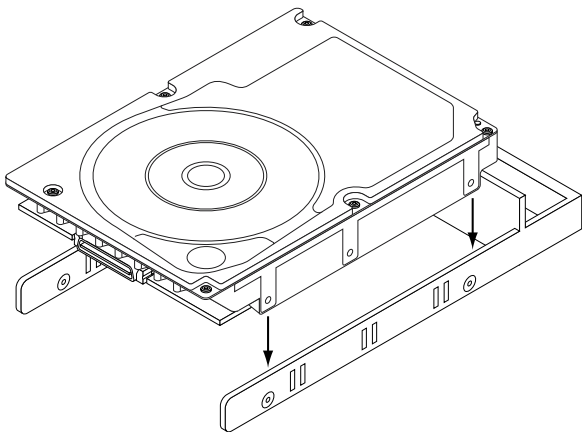

Figure 1. Sample drive carrier

Note. Figure 1 shows a generic carrier. Most carriers will look different than the one shown. Many are actually small enclosures rather than brackets as shown here.

2. Insert the drive

Slide the carrier or tray into the appropriate bay in your host system. This connects the drive directly to your system's 40-pin Fibre Channel single connector attachment (FC-SCA). The FC-SCA connector is normally located on a Fibre Channel backpanel.

Note. There are no jumpers or terminators on the drive, and power is supplied through the 40-pin connector.

3. Connect LEDs (optional)

Note. This is an optional step. The drive will work fine without the LEDs connected to the drive.

The drive supplies pins that you can use to connect fault and active LEDs. This allows you to monitor drive fault conditions and activity. The actual LED is external to the drive.

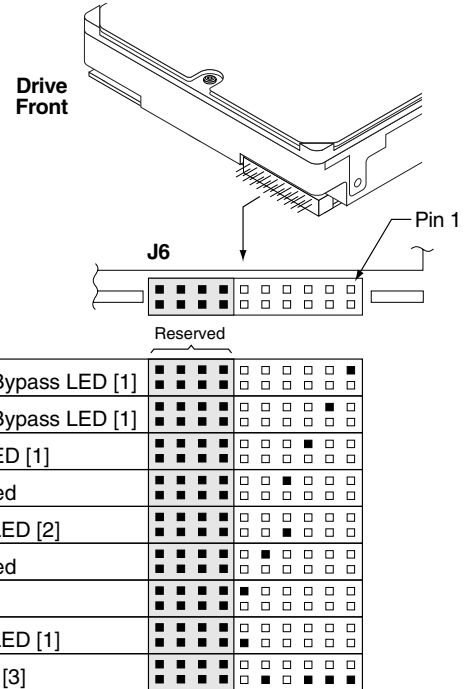

[1] The drive has a 1.2K ohm resistor in series with this LED driver. Tie the minus side of an external high-efficiency LED (i.e., 2ma) to this pin. Connect the plus side of the LED to +5V.

[2] An external current-limiting resistor is required when connecting an LED to this pin. The minus side of the resistor/LED combination is connected to this pin. Connect the plus side to +5V.

[3] Jumper storage location (across pins 2 and 4).

Figure 2. LED indicator connector

Fault LED Signal

The drive activates the fault LED Out signal when:

- the drive detects failure of both ports
- the drive detects an internal failure
- the drive receives the appropriate fault LED command from the host

Active LED signal

The drive activates the active LED signal as indicated below.

Normal command activity	LED status
Spun down and no activity	Slow blink (20% on and 80% off)
Spun down and activity	On
(command executing)	
Spun up and no activity	On
Spun up and activity	Off
(command executing)	
Spinning up or down.....	Blinks steadily (50% on and 50% off)
Format in progress	Toggles on/off
(each cylinder change)	

4. Format the drive

The drive has been *low level* formatted at the factory. You do not need to perform another low level format on this drive unless you decide to perform certain diagnostics through the host adapter. If you do decide to perform a low level format, do not abort the format as this is likely to make the drive inoperable. A low level format, with verify turned on, will typically take two hours.

Protect against power failure or other power interruptions during the format.

- a. Turn on DC power to the host system.
- b. Boot the system from a system floppy, CD, or from a previously installed hard disc drive if there is one.
- c. Format the drive.

Caution. Formatting a drive erases all user data. Be sure that you understand this principle before formatting any hard disc drive. It is not necessary to format a drive that previously has been used to store data, unless your intention is to erase all user data. Seagate® is not responsible for lost user data.

Cheetah® 10K.6 disc drives are designed to operate with a variety of operating systems. Please refer to your system or Fibre Channel host adapter (controller) manual for information about formatting and setting up the drive for use with your particular operating system.

Hot plugging the drive

This drive features hot plugging capabilities which allow you to insert and remove the drive without powering down the host system. Any time a drive is inserted or removed from a Fibre Channel loop, a short loop interruption occurs and the loop resynchronizes automatically to accommodate the added (or removed) drive.

Drive startup options

The drive's motor will start spinning the discs based on the status of two signals set by the host adapter. These two signals are called Start_1 and Start_2. There are four options as described below.

Option Start_2 Start_1 Motor spin function

- 1 Low Low Motor spins up at DC power on.
- 2 High Low Motor spins up when the host adapter sends the SCSI Start command.
- 3 Low High Motor spins up after a delay of 12 seconds times the physical address of the drive.
- 4 High High The drive will not spin up.

Most systems that host only a couple of drives use option 1 to enable all of the drives to start up immediately when power is applied to the drives. Systems hosting larger numbers of drives may be configured to start drives at various times to avoid overloading the capabilities of the host system's power supply.

If you want to change the startup option for the drive, please refer to the documentation provided with your Fibre Channel host adapter or host system.

Troubleshooting

- **Drive does not spin up.** Remove and then reinsert the drive into the drive bay on the host-supplied carrier or tray. Make sure the drive makes firm contact with the host's FC backpanel connector. Also, check the drive startup options for the Start_1 and Start_2 signals controlled from your host adapter. See "Drive Startup Options" above for the four possible startup options.
- **Computer does not seem to recognize the drive.** Verify that the drive is enabled by the FC host adapter setup utility.

Seagate support services

For online information about Seagate products, visit www.seagate.com or e-mail your disc questions to DiscSupport@Seagate.com.

If you need help installing your drive, consult your dealer first. If you need additional help, call a Seagate technical support specialist. Before calling, note your system configuration and drive model number (*ST3146807FC*, *ST373307FC* or *ST336607FC*).

Africa	+31-20-316-7222	New Zealand	0800-443988
Australia	1800-14-7201	Norway	800-113 91
Austria	0 800-20 12 90	Poland	00 800-311 12 38
Belgium	0 800-74 876	Spain	900-98 31 24
Denmark	80 88 12 66	Sweden	0 207 90 073
France	0 800-90 90 52	Switzerland	0 800-83 84 11
Germany	0 800-182 6831	Singapore	800-1101-150
Hong Kong	800-90-0474	Taiwan	+886-2-2514-2237
India	1-600-33-1104	Thailand	001-800-11-0032165
Indonesia	001-803-1-003-2165	Turkey	00 800-31 92 91 40
Ireland	1 800-55 21 22	United Kingdom	0 800-783 5177
Italy	800-790695	USA/Canada/	1-800 SEAGATE or
Malaysia	1-800-80-2335	Latin America	+1-405-936-1234
Middle East	+31-20-316-7222	Other European	
Netherlands	0 800-732-4283	countries	+31-20-316-7222

Warranty. Contact your place of purchase or our web site (above).

Return Merchandise Authorization (RMA). Before returning the drive, verify that it is defective. Seagate Worldwide customer service centers are the only facilities authorized to service Seagate drives. Contact nearest center for return procedures and trade regulations.

Shipping the drive

Caution. Back up the data before shipping. Seagate assumes no responsibility for data lost during shipping or service. Shipping drive in an unapproved container voids the warranty. Pack the drive with original box and packing materials. Use no other materials. This prevents electrical and physical damage in transit.