

Panasonic

Operating Instructions 3CCD Color Camera CCU

Model Nos. **GP-US932CU**
GP-US932CUE
GP-US932CUS
GP-US932CUSE

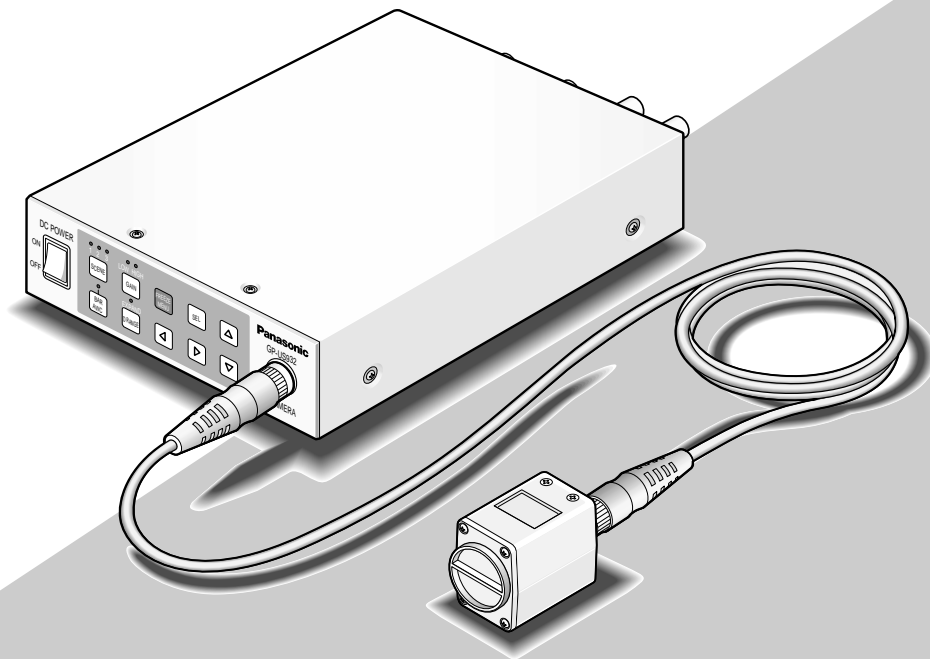

Camera head: option
Camera cable: option

HDMI[™]
HIGH-DEFINITION MULTIMEDIA INTERFACE

Before attempting to connect or operate this product,
please read these instructions carefully and save this manual for future use.

No model number suffix is shown in these Operating Instructions.

We declare under our sole responsibility that the product to which this declaration relates is in conformity with the standards or other normative documents following the provisions of Directives 2006/95/EC and 2004/108/EC.

Wir erklären in alleiniger Verantwortung, daß das Produkt, auf das sich diese Erklärung bezieht, mit der folgenden Normen oder normativen Dokumenten übereinstimmt. Gemäß den Bestimmungen der Richtlinie 2006/95/EC und 2004/108/EC.

Nous déclarons sous notre seule responsabilité que le produit auquel se réfère la présente déclaration est conforme aux normes ou autres documents normatifs conformément aux dispositions des directives 2006/95/CE et 2004/108/CE.

Nosotros declaramos bajo nuestra única responsabilidad que el producto a que hace referencia esta declaración está conforme con las normas u otros documentos normativos siguiendo las estipulaciones de las directivas 2006/95/CE y 2004/108/CE.

Noi dichiariamo sotto nostra esclusiva responsabilità che il prodotto a cui si riferisce la presente dichiarazione risulta conforme al seguente standard o altri documenti normativi conformi alle disposizioni delle direttive 2006/95/CE e 2004/108/CE.

Wij verklaren als enige aansprakelijke, dat het product waarop deze verklaring betrekking heeft, voldoet aan de volgende normen of andere normatieve documenten, overeenkomstig de bepalingen van Richtlijnen 2006/95/EC en 2004/108/EC.

Vi erklærer os eneansvarlige for, at dette produkt, som denne deklaration omhandler, er i overensstemmelse med standarder eller andre normative dokumenter i følge bestemmelserne i direktivene 2006/95/EC og 2004/108/EC.

Vi deklarerar härmed vårt fulla ansvar för att den produkt till vilken denna deklaration hänvisar är i överensstämmelse med standarddokument, eller andra normativa dokument som framställs i direktiv nr. 2006/95/EC och 2004/108/EC.

Ilmoitamme yksinomaisella vastuullamme, että tuote, jota tämä ilmoitus koskee, noudattaa seuraavia standardeja tai muita ohjeellisia asiakirjoja, jotka noudattavat direktiivien 2006/95/EC ja 2004/108/EC säädöksiä.

Vi erklærer oss alene ansvarlige for at produktet som denne erklæringen gjelder for, er i overensstemmelse med følgende normer eller andre normgivende dokumenter som følger bestemmelsene i direktivene 2006/95/EC og 2004/108/EC.

WARNING:

- To prevent fire or electric shock hazard, do not expose this apparatus to rain or moisture.
- The apparatus should not be exposed to dripping or splashing and that no objects filled with liquids, such as vases, should be placed on the apparatus.
- All work related to the installation of this product should be made by qualified service personnel or system installers.
- The connections should comply with local electrical code.

CAUTION:

Before attempting to connect or operate this product, please read the label on the bottom.

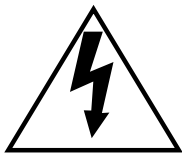
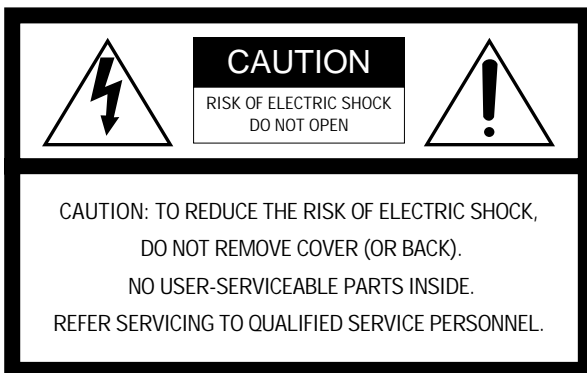

The lightning flash with arrowhead symbol, within an equilateral triangle, is intended to alert the user to the presence of uninsulated "dangerous voltage" within the product's enclosure that may be of sufficient magnitude to constitute a risk of electric shock to persons.



The exclamation point within an equilateral triangle is intended to alert the user to the presence of important operating and maintenance (servicing) instructions in the literature accompanying the appliance.

For U.S.A.

NOTE: This equipment has been tested and found to comply with the limits for a Class A digital device, pursuant to Part 15 of the FCC Rules. These limits are designed to provide reasonable protection against harmful interference when the equipment is operated in a commercial environment. This equipment generates, uses, and can radiate radio frequency energy and, if not installed and used in accordance with the instruction manual, may cause harmful interference to radio communications.

Operation of this equipment in a residential area is likely to cause harmful interference in which case the user will be required to correct the interference at his own expense.

FCC Caution: To assure continued compliance, (example - use only shielded interface cables when connecting to computer or peripheral devices). Any changes or modifications not expressly approved by the party responsible for compliance could void the user's authority to operate this equipment.

For U.S.A.

The serial number of this product may be found on the surface of the unit.

You should note the model number and serial number of this unit in the space provided and retain this book as a permanent record of your purchase to aid identification in the event of theft.

Model No. _____

Serial No. _____

Important Safety Instructions

- 1) Read these instructions.
- 2) Keep these instructions.
- 3) Heed all warnings.
- 4) Follow all instructions.
- 5) Do not use this apparatus near water.
- 6) Clean only with dry cloth.
- 7) Do not block any ventilation openings. Install in accordance with the manufacturer's instructions.
- 8) Do not install near any heat sources such as radiators, heat registers, stoves, or other apparatus (including amplifiers) that produce heat.
- 9) Do not defeat the safety purpose of the polarized or grounding-type plug. A polarized plug has two blades with one wider than the other. A grounding type plug has two blades and a third grounding prong. The wide blade or the third prong are provided for your safety. If the provided plug does not fit into your outlet, consult an electrician for replacement of the obsolete outlet.
- 10) Protect the power cord from being walked on or pinched particularly at plugs, convenience receptacles, and the point where they exit from the apparatus.
- 11) Only use attachments/accessories specified by the manufacturer.
- 12) Use only with the cart, stand, tripod, bracket, or table specified by the manufacturer, or sold with the apparatus. When a cart is used, use caution when moving the cart/apparatus combination to avoid injury from tip-over.



- 13) Unplug this apparatus during lightning storms or when unused for long periods of time.
- 14) Refer all servicing to qualified service personnel. Servicing is required when the apparatus has been damaged in any way, such as power-supply cord or plug is damaged, liquid has been spilled or objects have fallen into the apparatus, the apparatus has been exposed to rain or moisture, does not operate normally, or has been dropped.

CONTENTS

Important Safety Instructions	3
Limitation of Liability	5
Disclaimer of Warranty	5
Precautions	6
Preface	8
Trademarks and Registered Trademarks	8
Major Operating Controls and Their Functions	9
■ Camera head	9
■ Camera control unit (CCU)	9
Installation/Connection	13
■ How to mount lens	14
Setting Procedures	15
■ SETUP menu	15
■ Basic operations	16
1. Camera title setting [CAMERA ID]	17
2. ELC setting [ELC]	18
3. Electronic shutter setting [SHUTTER]	19
4. Gain adjustment [GAIN]	19
5. Electronic sensitivity enhancement setting [SENS UP]	19
6. Output signal setting [OUTPUT SEL]	19
7. Scene file setting [SCENE FILE]	20
8. White balance setting [WHITE BAL]	23
9. Black balance setting [BLACK BAL]	23
10. Synchronization setting [SYNC]	24
11. Electronic zoom setting [ELECTRIC ZOOM]	24
12. Image freezing [FREEZE]	24
■ Default setting restoring	24
SEL Menu	25
■ How to display or operate the SEL menu	25
■ Button assignment	25
Troubleshooting	26
Specifications	28
Standard Accessories	30
Optional Accessories	30

Limitation of Liability

THIS PUBLICATION IS PROVIDED "AS IS" WITHOUT WARRANTY OF ANY KIND, EITHER EXPRESS OR IMPLIED, INCLUDING BUT NOT LIMITED TO, THE IMPLIED WARRANTIES OF MERCHANTABILITY, FITNESS FOR ANY PARTICULAR PURPOSE, OR NON-INFRINGEMENT OF THE THIRD PARTY'S RIGHT.

THIS PUBLICATION COULD INCLUDE TECHNICAL INACCURACIES OR TYPOGRAPHICAL ERRORS. CHANGES ARE ADDED TO THE INFORMATION HEREIN, AT ANY TIME, FOR THE IMPROVEMENTS OF THIS PUBLICATION AND/OR THE CORRESPONDING PRODUCT (S).

Disclaimer of Warranty

IN NO EVENT SHALL MATSUSHITA ELECTRIC INDUSTRIAL CO., LTD. BE LIABLE TO ANY PARTY OR ANY PERSON, EXCEPT FOR REPLACEMENT OR REASONABLE MAINTENANCE OF THE PRODUCT, FOR THE CASES, INCLUDING BUT NOT LIMITED TO BELOW:

- (1) ANY DAMAGE AND LOSS, INCLUDING WITHOUT LIMITATION, DIRECT OR INDIRECT, SPECIAL, CONSEQUENTIAL OR EXEMPLARY, ARISING OUT OF OR RELATING TO THE PRODUCT;
- (2) PERSONAL INJURY OR ANY DAMAGE CAUSED BY INAPPROPRIATE USE OR NEGLIGENT OPERATION OF THE USER;
- (3) UNAUTHORIZED DISASSEMBLE, REPAIR OR MODIFICATION OF THE PRODUCT BY THE USER;
- (4) INCONVENIENCE OR ANY LOSS ARISING WHEN IMAGES ARE NOT DISPLAYED, DUE TO ANY REASON OR CAUSE INCLUDING ANY FAILURE OR PROBLEM OF THE PRODUCT;
- (5) ANY PROBLEM, CONSEQUENTIAL INCONVENIENCE, OR LOSS OR DAMAGE, ARISING OUT OF THE SYSTEM COMBINED BY THE DEVICES OF THIRD PARTY;
- (6) ANY CLAIM OR ACTION FOR DAMAGES, BROUGHT BY ANY PERSON OR ORGANIZATION BEING A PHOTOGENIC SUBJECT, DUE TO VIOLATION OF PRIVACY WITH THE RESULT OF THAT SURVEILLANCE-CAMERA'S PICTURE, INCLUDING SAVED DATA, FOR SOME REASON, BECOMES PUBLIC OR IS USED FOR THE PURPOSE OTHER THAN SURVEILLANCE.

Precautions

Do not attempt to disassemble this product.

To prevent electric shock, do not remove screws or covers. There are no user-serviceable parts inside. Ask a qualified service person for servicing.

Handle this product with care.

Do not abuse the product. Avoid striking, shaking, etc. The product could be damaged by improper handling or storage.

Cleaning this product body

Turn the power off when cleaning the product. Use a dry cloth to clean the product.

Do not use strong abrasive detergent when cleaning the product. When the dirt is hard to remove, use a mild detergent and wipe gently. Then, wipe off the remaining detergent with a dry cloth.

Otherwise, it may cause discoloration. When using a chemical cloth for cleaning, read the caution provided with the chemical cloth product.

Do not expose this product to rain or moisture, or try to operate it in wet areas.

Turn the power off immediately and ask a qualified service person for servicing. Moisture can damage the product, and also create the danger of electric shock.

Use this product for indoor use only.

Do not expose the product to direct sunlight for hours and do not install the product near a heater or an air conditioner. Otherwise, it may cause deformation, discoloration and malfunction. Keep the product away from water.

Do not drop anything inside this product.

Dropping a metal part or other materials inside the product could permanently damage the product.

Do not operate this product beyond the specified temperature, humidity, or power source ratings.

Use the product under conditions where temperature is between 0°C and +40°C {32°F and 104°F}, and humidity is below 90 %. The input power resource is 12 V DC.

Clean the faceplate with care.

Do not clean the faceplate with strong or abrasive detergents. Use lens tissue or a cotton tipped applicator and ethanol.

Discoloration on the CCD color filter

When continuously shooting a bright light source such as a spotlight, the color filter of the CCD may have deteriorated and it may cause discoloration. Even when changing the fixed shooting direction after continuously shooting a spotlight for a certain period, the discoloration may remain.

Do not aim the camera head at strong light sources.

A light source such as a spot light causes a blooming (light bleeding) or a smear (vertical lines).

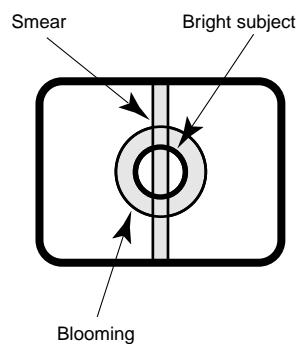

Installing place

Contact your dealer for assistance if you are unsure of an appropriate place in your particular environment.

Make sure that the installation area is strong enough to hold the product, such as a concrete ceiling. When the installation area is not strong enough, reinforce and strengthen it.

Avoid installing in the following locations.

- Locations where it may get wet from rain or water splash
- Locations where a chemical agent is used such as a swimming pool (not only outdoor)
- Locations subject to steam and oil smoke such as a kitchen
- Locations near flammable gas or vapor
- Locations where radiation or x-ray emissions are produced
- Locations subject to strong magnetic field or radio waves
- Locations where corrosive gas is produced
- Locations where it may be damaged by briny air such as seashores
- Locations where the temperature is not between 0°C and +40°C {32°F and 104°F}.
- Locations subject to vibrations (the product is not designed for on-vehicle use.)
- Locations subject to condensation as the result of severe changes in temperature

Be sure to remove this product if it is not in use.

Radio interference

When the product is used near TV/radio antenna, strong electric field or magnetic field (near a motor or a transformer), images may be distorted and noise sound may be produced.

Do not install this product in a humid or dust-laden environment.

Otherwise, lifetime of the internal parts may be shortened.

Preface

This system is a compact and light type HD camera control unit (hereafter called CCU) with high image quality and multiple functions by introducing digital signal processing. The camera head is separately mounted.

- GP-US932CU, GP-US932CUE, CCU for 3CCD color camera (HDMI output connector equipped)
- GP-US932CUS, GP-US932CUSE, CCU for 3CCD color camera (SDI output connector equipped)

This unit is used in combination with the optional 3CCD HD camera head.

- GP-US932H, GP-US932HE, camera head for 3CCD color camera

- The multi-format output applicable to 1 080i, 720p, 480p (576p*) and 480i (576i*) is available.
 - * The value is for GP-US932CUE/GP-US932CUSE.
- Signal transmission without signal degradation has been achieved thanks to the HDMI or SDI output connectors.
- The dynamic range expansion function allows users to shoot even images with a wide range of brightness contrast and facilitate their visibility.

These instructions explain the system that consists of this unit and the optional camera head.

Trademarks and Registered Trademarks

HDMI, the HDMI logo and High-Definition Multimedia Interface are trademarks or registered trademarks of HDMI Licensing LLC.

Major Operating Controls and Their Functions

■ Camera head

① Lens mount section

C-mount lens is mounted on this section. (⇨ page 14)

② Camera cable connector

This connector is used to connect the camera cable (option).

<Camera cable> (option)

GP-CA932/4, GP-CA932/4E (4 m {13.1 ft.})

GP-CA932/6, GP-CA932/6E (6 m {19.7 ft.})

③ Tripod socket

The tripod socket hole is used when the camera head is secured to the tripod.

The tripod socket can be mounted on either top or bottom of the camera head.

Tripod socket hole: 1/4-20 UNC

Important:

- Be sure to turn off the power of the CCU before connecting or disconnecting the camera cable.
- Avoid bending excessively or breaking the camera cable.
- Use the specific-camera head only.

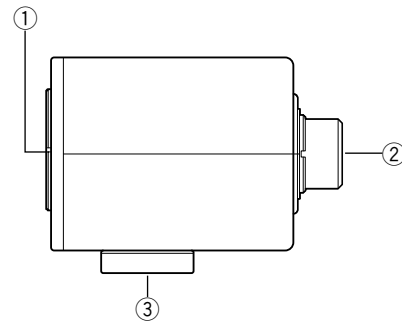

■ Camera control unit (CCU)

<Front>

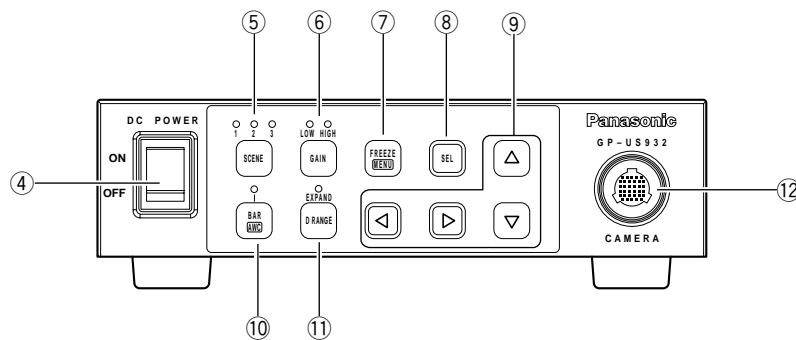

④ Power switch [DC POWER]

This switch toggles the power of the CCU and camera head on and off. The switch lights green while the power is turned on.

⑤ Scene file selection button [SCENE]

The button selects a scene file from 1 to 3. Each scene file should be set up beforehand using the SETUP menu. (⇨ page 20)

Selection of a scene file turns on the green LED of the selected file number.

⑥ Gain selection button [GAIN]

This button selects a gain from OFF, LOW, and HIGH.

Selection of a gain turns on the green LED of the selected gain. No LED is turned on when the gain is set to off.

Selectable gain varies depending on the setting in the SETUP menu (⇨ page 19).

When GAIN is set to "AUTO" and SENS UP is set to "OFF": The gain is always set to "HIGH".

⑦ Freeze/menu button [FREEZE (MENU)]

Pressing this button: Displays the current image as a static image when "FREEZE" in the SETUP menu is set to "ON".

Notes:

- Pressing a button other than the [g] and [h] buttons provides freeze cancellation.
- When the zoom in and out functions are assigned to the [e] and [f] buttons respectively, the image can be scaled up and down in the image freezing state.

Refer to page 25 for function assignment to buttons.

Holding down this button (for more than 2 seconds):

Displays the SETUP menu.

⑧ Selection button [SEL]

Pressing this button while the SETUP menu is displayed determines the setting.

Pressing this button except while the SETUP menu is displayed calls up the SEL menu. (⇐ page 25)

⑨ Up/down/left/right buttons

Up button [g]: This button moves the cursor upward to change a setting item while the SETUP menu is displayed.

Down button [h]: This button moves the cursor downward to change a setting item while the SETUP menu is displayed.

Left button [e]: This button moves the cursor leftward or selects a setting while the SETUP menu is displayed.

This button moves the cursor in the minus direction on the level adjustment scale or selects a setting item while the SEL menu is displayed.

When the zoom out function is assigned to the left button, the image can be scaled down (⇐ page 25).

Right button [f]: This button moves the cursor rightward or selects a setting while the SETUP menu is displayed.

This button moves the cursor in the plus direction on the level adjustment scale or selects a setting item while the SEL menu is displayed.

When the zoom in function is assigned to the right button, the image can be scaled up (up to 2.5-fold) (⇐ page 25).

⑩ Color bar display/AWC button [BAR/AWC]

Pressing this button: Calls up the color bar on the screen while an image is displayed. The color bar becomes a blue back display while the SETUP menu is displayed.

Holding down this button (for more than 2 seconds):

Starts up AWC while an image is displayed if "WHITE BAL" in the SETUP menu is set to "AWC".

Important:

- When the camera head is not connected, pressing the [BAR/AWC] button does not activate any operation.

⑪ Dynamic range button [D RANGE]

This button toggles the dynamic range between NORMAL and EXPAND. The button lights green when "EXPAND" is selected.

"EXPAND" shall be selected when dark portions are less viewable because too bright portions are present in a screen. (⇐ page 21)

Note: The dynamic range can also be set in the scene file. (⇐ page 20)

⑫ Camera cable connector

This connector is used to connect the camera cable (option).

<Rear>

● GP-US932CU, GP-US932CUE

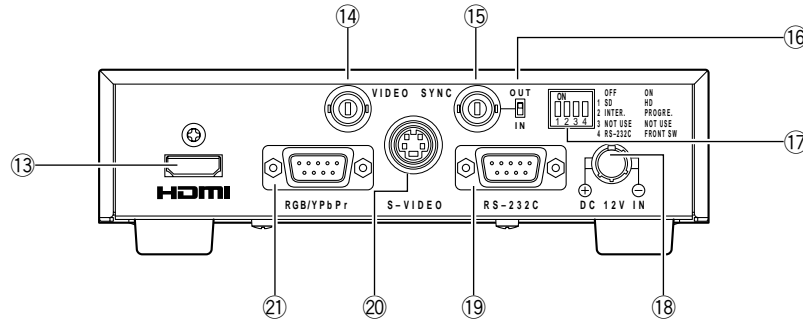

● GP-US932CUS, GP-US932CUSE

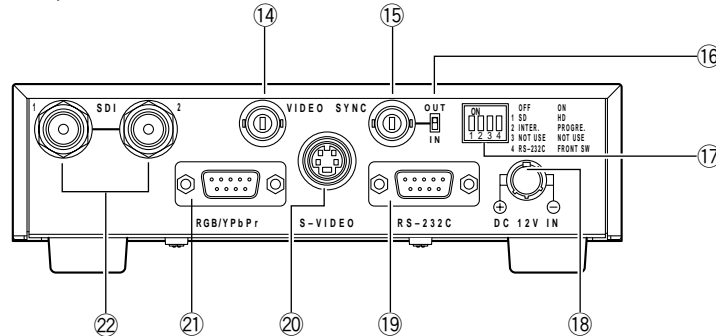

13 **HDMI output connector [HDMI] (* only for GP-US932CU, GP-US932CUE)**

This connector is used when an HDMI-ready monitor is connected.

14 **Video output connector [VIDEO]**

This connector provides composite video signals (1.0 V[P-P], 75 ohms).

15 **Synchronizing signal output/input connector [SYNC]**

When an external device is synchronized, set the synchronizing signal output/input selection switch 16 to "IN" to provide the synchronizing signal input.

When the synchronizing signal output/input selection switch 16 is set to "OUT", the connector provides the synchronizing signal output conformable to the video format of this system.

Important:

- The video format shall be the same among the synchronized devices.

16 **Synchronizing signal output/input selection switch [OUT/IN]**

This switch toggles synchronizing signals between output and input.

When the synchronizing signal output is selected, set this switch to "OUT". When the synchronizing signal input is selected, set this switch to "IN".

17 **Function setup switches**

These switches select a video format for RGB/YPbPr

output connector, SDI output connector, and HDMI output connector.

Switch	OFF	ON
1	SD (SD signal output)	HD (HD signal output)
2	INTER. (Interlace output)	PROGRE. (Progressive output)
3	NOT USE (Not used)	NOT USE (Not used)
4	RS-232C (RS-232C control)	FRONT SW (Button operation via front face)

Video format	Switch		RGB/YPb Pr output	SDI output	HDMI output
	1	2			
1 080i	ON	OFF	b	b	b
720p	ON	ON	b	b	b
480p (576p*)	OFF	ON	b	X	b
480i (576i*)	OFF	OFF	b	b	X

X: No output is provided.

* The value is for GP-US932CUE/GP-US932CUSE.

Note:

- When the RS-232C port is used, set Switch 4 to "OFF" after turning off the power. When Switch 4 is set to "OFF", button operations on the front face are disabled.

18 12 V DC power connector [DC 12V IN]

This connector is used to connect an external DC power supply of 12 volts (2 A or more).

Important:

- A class 2 power supply of 12 V DC (10.8 to 13.2 volts) shall be used.

Compatible connector
HR10A-7P-4S (73) manufac-
tured by HIROSE ELECTRIC
CO., LTD. (as of October 2007)

Pin arrangement of
applicable connector

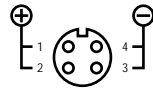

(Cable side)

22 SDI output connector [SDI]

(* only for GP-US932CUS, GP-US932CUSE)

This connector provides HD-SDI or SD-SDI output sig-
nals.

Important:

- Please use a high quality cable compatible with HD-SDI.

19 RS-232C port [RS-232C]

This port is used to perform external control. Please
contact your dealer for further information.

(D-sub 9-pin connector,
female)

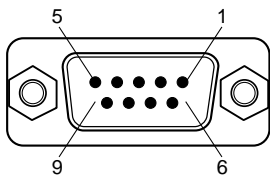

Pin number	Signal
1	GND
2	TXD
3	RXD
4	DSR
5	GND
6	DTR
7	CTS
8	RTS
9	GND

20 S-video output connector [S-VIDEO]

This connector provides the luminance signal (Y) output
and color signal (C) output with synchronizing signals.

21 RGB/YPbPr connector [RGB/YPbPr]

This connector provides the RGB signal (red, green,
and blue) output or the YPbPr signal (luminance, color
difference B, and color difference R) output. The output
signal can be set up with use of "OUTPUT SEL" in the
SETUP menu. (⇨ page 19)

(D-sub 9-pin connector,
male)

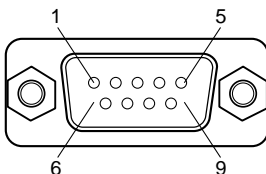

Pin number	Output signal
1	GND
2	GND
3	R, Pr
4	G, Y
5	B, Pb
6	VIDEO
7	SYNC
8	GND
9	GND

Installation/Connection

Caution:

ONLY CONNECT THIS TO 12 V DC CLASS 2 POWER SUPPLY.
Be sure to connect the grounding lead to the GND terminal.

The following shows how to mount the camera on the tripod (locally procured).
The tripod socket can be mounted on either top or bottom of the camera head.

<Sample of camera mounting on tripod>

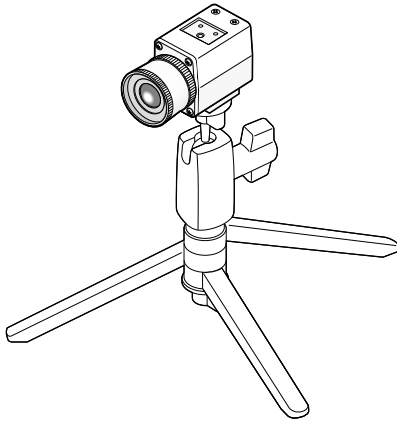

<Change of tripod socket position>

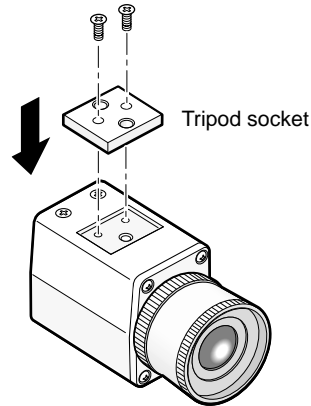

Important:

- The tripod and CCU shall be horizontally placed.
- When the camera head is mounted on a ceiling, the camera cable (option) also plays a role of a safety wire for just in case. Use a cable tie to attach the camera cable to the camera mounting base. The cable tie shall be made of a durable material.
- An installation area for the camera mounting base shall be strong enough to support the total weight.

<Sample of camera mounting on ceiling>

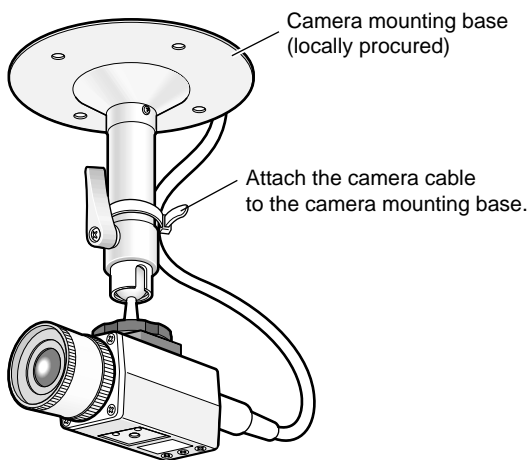

■ How to mount lens

Important:

- Be sure to turn off the power of the CCU before mounting a lens.
- A lens whose projection length of the lens mount section is 4 mm or less shall be used.
- The recommended lens aperture ranges from F2.2 to F16. Selection of less than F2.2 of the lens aperture may result in image blurring.
- When a zoom lens is used, focus adjustment method varies with the lens. For further information, refer to the operating instructions for the lens.
- When the lens is removed, be sure to put the cap on the lens mount section of the camera head.

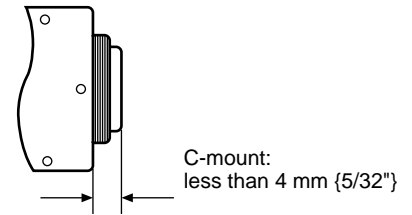

Z Remove the lens cap from the lens mount section of the camera head.

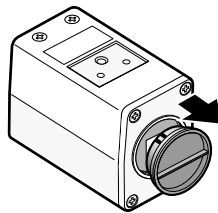

X Turn a C-mount lens clockwise to engage the lens with the lens mount section.

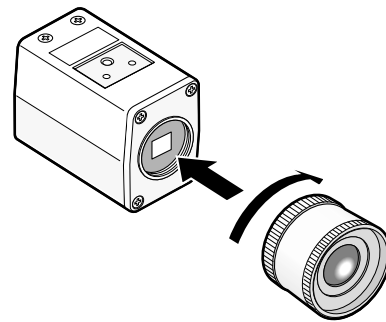

Important:

- Check to see whether the surface of the optical filter is clean before mounting a lens. If the surface is dirty, use a blower brush for general camera to remove dust.

Recommended lenses (as of October 2007)

Manufacturer	Model	Model number
FUJINON	High Definition Fixed Lens	HAF4.8DA-1
FUJINON	High Definition Zoom Lens	HA4x7.5DA-1
FUJINON	3CCD Camera Lens	TF2.8DA-8
FUJINON	3CCD Camera Lens	TF4DA-8
FUJINON	3CCD Camera Lens	TF8DA-8
FUJINON	3CCD Camera Lens	TF15DA-8

Setting Procedures

Performing each setting item on the SETUP menu should be completed in advance to use this unit. Perform the settings for each item in accordance with the conditions of the camera shooting location.

Note:

- In addition to the SETUP menu, this system has a simplified menu (SEL menu) that is displayed using the [SEL] button on the front of the CCU. Refer to page 25 for further information about the SEL menu.

■ SETUP menu

The following items can be set with use of the SETUP menu.

Setup items	Description	Page
① CAMERA ID	Specifies the camera title. Through this item, a camera title is created with alphanumeric and symbol characters, and displayed on the screen.	17
② ELC	Specifies the ELC function.	18
③ SHUTTER	Specifies the electronic shutter speed.	19
④ GAIN	Adjusts the gain.	19
⑤ SENS UP	Specifies electronic sensitivity enhancement.	19
⑥ OUTPUT SEL	Specifies the output signal.	19
⑦ SCENE FILE	Registers the settings of details, gamma, hue, etc.	20
DTL MODE	Specifies the details.	20
RED DTL	Adjusts the enhancement of red edge.	20
GAMMA	Performs gamma adjustment.	20
KNEE	Adjusts the knee point.	21
BLACK STRETCH	Toggles the black stretch function on and off.	21
D-RANGE	Toggles the dynamic range between NORMAL and EXPAND.	21
WHITE CLIP	Adjusts the white clip level.	21
FLARE COMP	Performs flare compensation.	21
DNR	Specifies the level of the digital noise reduction function.	21
MATRIX	Adjusts the hue.	21
CHROMA GAIN	Adjusts chroma gain.	22
TOTAL PED	Adjusts the pedestal level.	22
⑧ WHITE BAL	Specifies white balance adjustment.	23
⑨ BLACK BAL	Adjusts the black balance.	23
⑩ SYNC	Specifies the synchronization type.	24
⑪ ELECTRIC ZOOM	Toggles the electronic zoom on and off.	24
⑫ FREEZE	Toggles the freeze function.	24

■ Basic operations

The description below explains how to operate the SETUP menu basically.

First of all, the explanation provides how to display the SETUP menu on the connected monitor used for adjustment.

Important:

- The following functions are not available when the camera head is not connected.
 - Startup of white balance AWC
 - MATRIX
 - ELECTRIC ZOOM
 - FREEZE

Top screen of SETUP menu

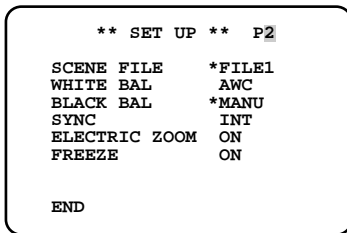
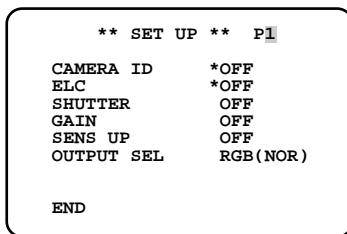

Z Hold down the [FREEZE (MENU)] button for approx. 2 seconds.

→ The top screen of the SETUP menu appears.

X The SETUP menu consists of 2 pages.

To change the page, move the cursor to "P1" or "P2" and press the [e] or [f] button.

Note:

- The cursor is a blinking part.

C Perform the settings for each item.

- Selection of setting item:
Press the [g] button or the [h] button to move the cursor.
- Change of settings:
Press the [e] button or the [f] button.
- Display of advanced setup screen:
Press the [SEL] button when "*" is attached to the target setting item.
- Return to previous setup screen:
Move the cursor to "RET" and press the [SEL] button.

V To return to the camera image screen after storing the settings, move the cursor to "END" and press the [SEL] button.

The settings can be stored even if the power of the CCU is turned off.

1. Camera title setting [CAMERA ID]

This item specifies the camera title. The camera title that indicates the camera location and other information about the camera is created with alphanumeric, symbol, and katakana characters and displayed on the screen. The camera title is named with up to 16 characters. Follow the procedure below to specify the camera title.

Top screen of SETUP menu

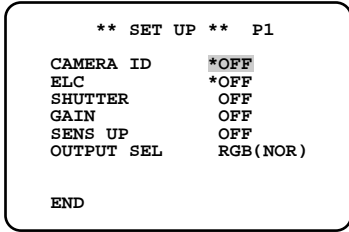

Title creation screen

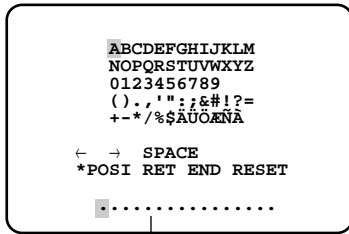

Editing area

Display positioning screen

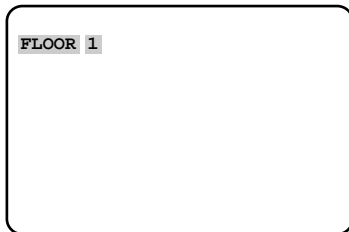

- Z Set "CAMERA ID" to "ON" and press the [SEL] button.
→ The title creation screen appears.

Note:

- Even if "CAMERA ID" is set to "OFF", pressing the [SEL] button calls up the title creation screen.

Important:

- When "CAMERA ID" is set to "OFF", the camera title does not appear even if the title is specified.

- X Move the cursor to the target item with use of the [g], [h], [e], and [f] buttons and press the [SEL] button.
→ The entered characters are displayed in the entry range.

<Character entry>

- To revise the character, move the cursor to "←" or "→" and press the [SEL] button.
Move the cursor to the character to be revised in the entry range and enter a character newly.
- To enter a blank, move the cursor to "SPACE" and press the [SEL] button.
- To delete all the entered characters, move the cursor to "RESET" and press the [SEL] button.

- C Move the cursor to "POSI" and press the [SEL] button after title entry.
→ The display positioning screen appears to show the entered camera title blinking.
- V Position the title with use of the [g], [h], [e], and [f] buttons and hold down the [MENU] button for more than 2 seconds.
→ The title position is decided and the title creation screen appears again.

2. ELC setting [ELC]

Setting ELC (electronic light control) to ON provides automatic adjustment of the screen brightness. The convergence level of ELC can be specified at "BRIGHTNESS" in the SEL menu (⇨ page 25).

If a photographic subject has a bright light such as a spotlight in its background, the subject may appear shadowy. To eliminate this phenomenon, mask the bright area in the background to perform correction.

Top screen of SETUP menu

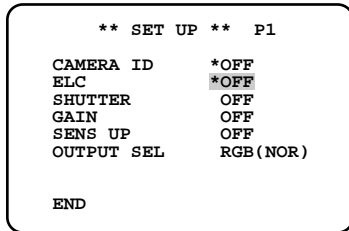

"ELC CONT" screen

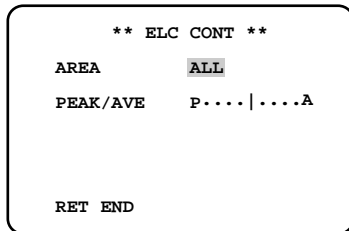

Z Set "ELC" to "ON" and press the [SEL] button.
→ The "ELC CONT" screen appears.

X Move the cursor to "AREA" and use the [e] and [f] buttons to select an area.
The area is selectable from the types shown below.
→ The detection areas shown as follows are not displayed.

ALL (default): All of the areas on the screen are the detection area.

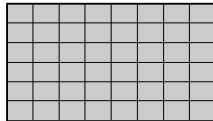

S CIRCLE: The small circle in the center of the screen is the detection area.

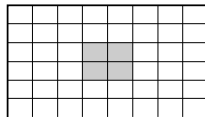

M CIRCLE: The medium circle in the center of the screen is the detection area.

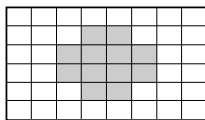

L CIRCLE: The large circle in the center of the screen is the detection area.

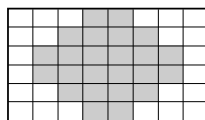

MANU: The detection area can be manually specified.
(⇨ page 18)

AUTO: The dark areas are automatically covered and only the bright areas are automatically detected.

C Move the cursor to "PEAK/AVE" and use the [e] and [f] buttons to adjust the detection level.
When the cursor is moved to "P", the peak value (maximum) is detected. When the cursor is moved to "A", the average value is detected.

Manual setup of detection area

The detection area is manually specified.

"ELC CONT" screen

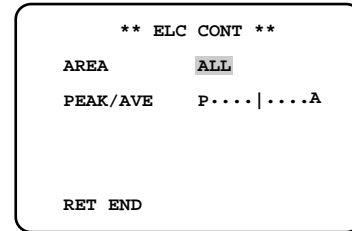

Mask setting screen

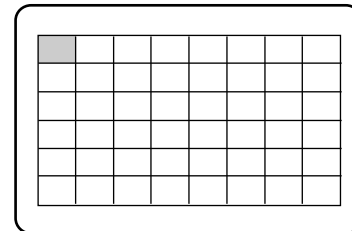

Z Select "MANU" for "AREA" on the "ELC CONT" screen and press the [SEL] button.
→ The mask setting screen appears.

X Use the [g], [h], [e], and [f] buttons to select an area to be masked and press the [SEL] button.
→ The selected area is displayed white.

Note:

- To cancel the specified area, move the cursor to the target area and press the [SEL] button.
To cancel all the masks, hold down the [e] and [f] buttons simultaneously for more than 2 seconds.

C Hold down the [MENU] button for more than 2 seconds after area setting.
→ The "ELC CONT" screen appears again.

3. Electronic shutter setting [SHUTTER]

The electronic shutter speed is specified. The speed is selectable from the following.

OFF (default), 1/100 (1/120*), 1/250, 1/500, 1/1000, 1/2000, 1/4000, 1/10000, and MANU

Select "MANU", and press [SEL] button. The "SHUTTER" screen appears to adjust the shutter speed in detail.

Adjustable speed range: 3/562 (2/562*) – 552/562

* The value is for GP-US932CUE/GP-US932CUSE.

"SHUTTER" screen

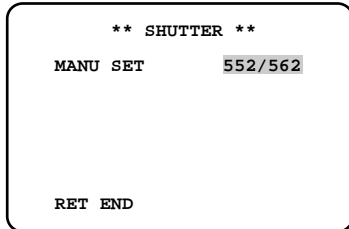

Note:

- When the shutter speed is specified, be sure to set both "ELC" and "SENS UP" to "OFF". (☞ pages 18 and 19)

4. Gain adjustment [GAIN]

The gain adjustment is selectable from the following.

OFF (default): The gain is not adjusted.

AUTO (L), AUTO (H): The gain is automatically adjusted.

MANU (L), MANU (H): The gain is manually adjusted.

The gain level is adjusted in detail.

The gain can be finely adjusted in the "LOW" and "HIGH" levels.

Z Select an adjustment in "GAIN" and press the [SEL] button.

→ The "GAIN LEVEL" screen appears.

X Move the cursor to "HIGH" or "LOW" and adjust the level with use of the [e] or [f] button.

"GAIN LEVEL" screen

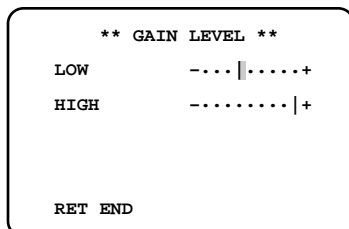

Important:

- The "LOW" level cannot be larger than the "HIGH" level.
- When "SENS UP" is set to "OFF" or "---", "AUTO (L)" is not available.

5. Electronic sensitivity enhancement setting [SENS UP]

The magnification of the electronic sensitivity is selectable from the following.

OFF (default), AUTO (x2), AUTO (x4), AUTO (x8), MANU (x2), MANU (x4), and MANU (x8)

Notes:

- When "MANU (x2)", "MANU (x4)", or "MANU (x8)" is selected, be sure to set "ELC" to "OFF". (☞ page 18)
- When "GAIN" is set to "OFF" or to a low level, video may become grainy and unstable. In such a case, adjust the electronic sensitivity.
- When "SHUTTER" is set to other than "OFF", "---" appears and electronic sensitivity enhancement function is not available.
- When the electronic sensitivity enhancement function is used, time for CCD readout is elongated to enhance the sensitivity. Therefore, the residual image of a moving subject is increased in accordance with the magnification of the sensitivity.

6. Output signal setting [OUTPUT SEL]

The output signals of RGB/YPbPr output connector, HDMI output connector are specified.

Output signals vary with models.

GP-US932CU, GP-US932CUE (HDMI output connector equipped): RGB (NOR) (default), RGB (ENH), YPbPr (422), YPbPr (444)*

- * The output signal of the RGB/YPbPr output connector is the same in both RGB (NOR) and RGB (ENH) and in both YPbPr (422) and YPbPr (444), respectively.

GP-US932CUS, GP-US932CUSE (SDI output connector equipped): RGB (default), YPbPr

7. Scene file setting [SCENE FILE]

Registration of details, gamma, hue, etc. as a scene file in accordance with an installation location allows users to employ the registered contents only by pressing the [SCENE] button on the front face of the CCU.

Up to 3 scene files can be registered.

Scene file registration is performed on the "SCENE FILE" screen. When a scene file to be registered on the top screen, "SCENE FILE", in the SETU P menu is selected and the [SEL] button is pressed, the "SCENE FILE" screen appears. The "SCENE FILE" screen consists of 2 pages. The selected scene file number appears beside the screen title.

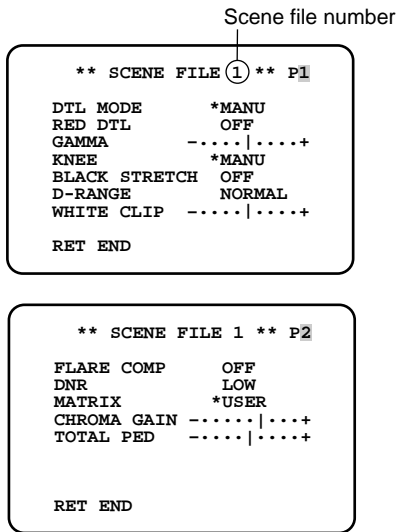

[DTL MODE] Specifies the details.

The band and level of the edge correction are specified.

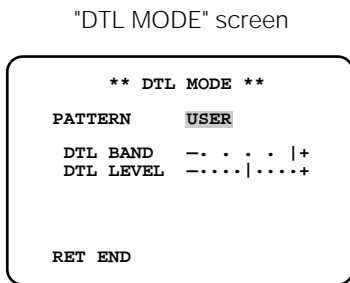
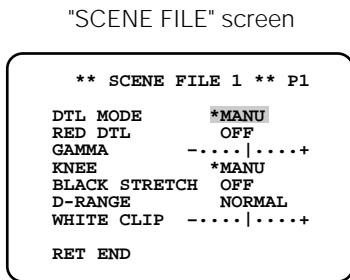

Z Move the cursor to "DTL MODE" on the "SCENE FILE" screen and press the [SEL] button.

→ The "DTL MODE" screen appears.

X Move the cursor to "PATTERN", select a pattern from among "1", "2" and "3", and press the [SEL] button.

→ The settings of "DTL BAND" and "DTL LEVEL" are applied to "USER".

The band and level can be manually adjusted in "USER". Perform adjustment on an as-needed basis.

Be sure to view the monitor when the adjustment is performed.

Note:

- The band and level can also be adjusted directly without applying any of the patterns, "1", "2", and "3" to "USER".

C Move the cursor to "DTL BAND" and adjust the band with use of the [e] or [f] button.

When the level indicator moves in the "+" direction, the edge becomes thinner (band becomes higher). When the level indicator moves in the "-" direction, the edge becomes thicker (band becomes lower).

V Move the cursor to "DTL LEVEL" and adjust the level with use of the [e] or [f] button.

When the level indicator moves in the "+" direction, the image becomes sharper. When the level indicator moves in the "-" direction, the image becomes softer.

Note:

- Jaggies may appear on the edge of a photographic subject, but this phenomenon is not abnormal. If this phenomenon is not favorable, decrease "DTL BAND" or "DTL LEVEL" to adjust the image quality.

[RED DTL] Adjusts the enhancement of red edge.

The red edge enhancement level of images through the camera is adjusted.

The enhancement level is selectable from the following.

OFF (default): No edge enhancement is performed on the red portion.

LOW: The low level of edge enhancement is performed on the red portion.

HIGH: The high level of edge enhancement is performed on the red portion.

[GAMMA] Performs gamma adjustment.

Be sure to view a waveform monitor or a color video monitor when the gamma adjustment is performed.

Move the cursor to "GAMMA" and adjust the gamma level with use of the [e] or [f] button.

When the level indicator moves in the "+" direction, the correction level becomes larger. When the level indicator moves in the "-" direction, the correction level becomes smaller.

Moving the cursor to the far end of the "+" direction sets the gamma correction to OFF.

Important:

- In the case of the following, "---" appears and gamma adjustment is not available.
- When "BLACK STRETCH" is set to "ON"
- When "D-RANGE" is set to "EXPAND"

[KNEE] Adjusts the knee point.

Be sure to view a waveform monitor or a color video monitor when the knee point adjustment is performed.

The knee point adjustment is selectable from the following.

MANU (default): The knee point is manually adjusted.

AUTO: The knee point is automatically adjusted.

When "MANU" is selected, follow the steps below to adjust the knee point.

- Z Select "MANU" and press the [SEL] button.
→ The "KNEE MANU" screen appears.
- X Adjust the knee point with use of the [e] or [f] button.

Important:

- When "D-RANGE" is set to "EXPAND", the knee point adjustment is disabled.

"KNEE MANU" screen

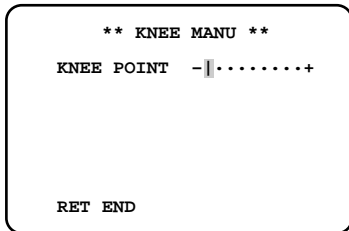

[BLACK STRETCH] Toggles the black stretch function on and off.

Selection "ON" or "OFF" (default) determines whether or not to perform the black stretch function.

When "ON" is selected, black crushing is corrected at low illuminance to make an image more viewable.

Important:

- When "D-RANGE" is set to "EXPAND", the black stretch setting is disabled.

[D-RANGE] Toggles the dynamic range between NORMAL and EXPAND.

The dynamic range is set to "NORMAL" (default) or "EXPAND".

Selection of "EXPAND" makes high contrast images more viewable.

[WHITE CLIP] Adjusts the white clip level.

Be sure to view a waveform monitor or a color video monitor when the white clip level is adjusted with use of the [e] or [f] button.

When the level indicator moves in the "+" direction, the level becomes higher. When the level indicator moves in the "-" direction, the level becomes lower.

Important:

- When "D-RANGE" is set to "EXPAND", the white clip adjustment is disabled.

[FLARE COMP] Performs flare compensation.

Selection "ON" or "OFF" (default) determines whether or not to perform the flare compensation.

When "ON" is selected, flare is reduced.

[DNR] Specifies the level of the digital noise reduction function.

The digital noise reduction function reduces noise. The effect level is selectable from the following.

LOW (default): The low level of digital noise reduction is performed. (smaller residual image)

HIGH: The high level of digital noise reduction is performed. (larger residual image)

OFF: The digital noise reduction function is disabled.

[MATRIX] Adjusts the hue.

Be sure to view a vector scope or a color video monitor when the hue adjustment is performed.

"SCENE FILE" screen

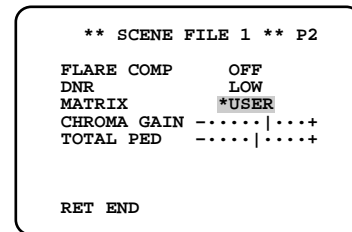

"MATRIX" screen

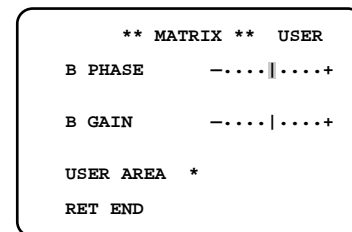

- Z Display your target color in the screen center as large as possible.

- X Select the axis close to your target color using "MATRIX" on the "SCENE FILE" screen. The axis is selectable from the following.

USER (default), B-Mg, Mg, Mg-R, R, R-Ye, Ye, Ye-G, G, G-Cy, Cy, Cy-B, and B

- C Press the [SEL] button after axis selection.
→ The "MATRIX" screen appears.
- ✓ To perform fine tuning, use the [e] or [f] button to adjust "GAIN" (chroma) and "PHASE" (hue).

When the color axis is unclear

When "USER AREA" is selected on the "MATRIX" screen, the axis is automatically displayed by selecting a color on the screen.
Color selection is performed on the color detection screen. The white rectangle cursor is blinking to select a target color on the color detection screen.

<Color matrix splitting chart>

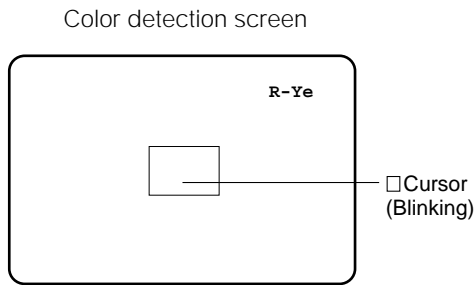

* This chart is a guideline for displaying the closest axis at adjustment.

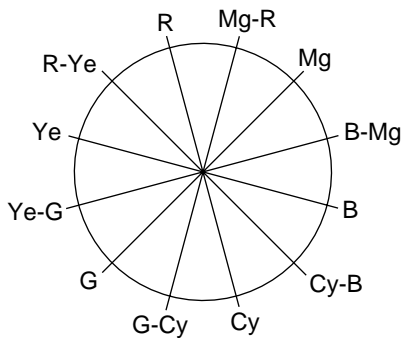

- Z Point the camera at the center of the photographic subject with which the color is detected.
If the camera is immovable, move the rectangle cursor to the area with a target color with use of the [g], [h], [e], and [f] buttons.

Note:

- Every time the [SEL] button is pressed, the size of the rectangle cursor changes in the order of large → medium → small.
Select a size to meet the photographic subject size.
- X Hold down the [MENU] button for more than 2 seconds.
→ The "MATRIX" screen appears again.
- C To perform fine tuning, adjust "GAIN" (chroma) and "PHASE" (hue).
For example, the adjustment of "PHASE" or "GAIN" of "R/R-Ye" on the following screen provides the simultaneous adjustment of "PHASE" or "GAIN" of the adjacent axes "R" and "R-Ye" in "Color matrix splitting chart".

```

** MATRIX ** USER
R/R-Ye PHASE -....||.....+
R PHASE      -....||.....+
R-Ye PHASE   -....||.....+
R/R-Ye GAIN  -....||.....+
R GAIN       -....||.....+
R-Ye GAIN    -....||.....+
USER AREA *
RET END

```

Note:

- When the color on the axis in the color matrix splitting chart is detected, the adjacent axes are not displayed.

[CHROMA GAIN] Adjusts chroma gain.

Be sure to view a vector scope or a color video monitor when the chroma gain is adjusted with use of the [e] or [f] button.
When the level indicator moves in the "+" direction, the chroma level becomes higher. When the level indicator moves in the "-" direction, the chroma level becomes lower.

[TOTAL PED] Adjusts the pedestal level.

Be sure to view a waveform monitor or a color video monitor when the pedestal level is adjusted with use of the [e] or [f] button.
When the level indicator moves in the "+" direction, the image becomes brighter. When the level indicator moves in the "-" direction, the image becomes darker.

8. White balance setting [WHITE BAL]

The white balance adjustment is selectable from the following.

AWC (default): The automatic white balance control mode is activated. This adjustment is suitable for a location where a light source is stable.

When "AWC" is selected, the operation to adjust the white balance is required.

ATW: Activates the automatic white balance tracking mode.

The camera continuously measures the white balance and automatically performs adjustment.

If the situation meets one of the following or other, color may not be accurately reproduced. In such a case, select "AWC" to adjust the white balance.

- The photographic subject is mostly highly-colored.
- The photographic atmosphere is under the bright blue sky or at nightfall.
- The illumination of the light illuminating the photographic subject is low.

MANU: The white balance is manually adjusted.

When "AWC" is selected, follow the steps below to adjust the white balance.

- Z Point the camera at a white photographic subject.
- X Hold down the [BAR (AWC)] button for more than 2 seconds on the front face of the CCU.
 - AWC starts up and the LED located above the [BAR (AWC)] button blinks. When "AWC OK" appears and the LED goes out, the adjustment is completed.

Note:

- "AWC NG" appears. Perform the steps 1 and 2 again if "AWC NG" appears and the LED stays on.

When "MANU" is selected, follow the steps below to adjust the white balance.

- Z Select "MANU" and press the [SEL] button.
 - The "WHITE BAL" screen appears.
- X Move the cursor to "R-GAIN" or "B-GAIN" and adjust the white balance with use of the [e] or [f] button.

"WHITE BAL" screen

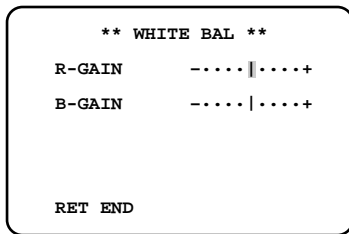

9. Black balance setting [BLACK BAL]

The black balance adjustment is generally unnecessary, but the adjustment is available also by hand.

Top screen of SETUP menu

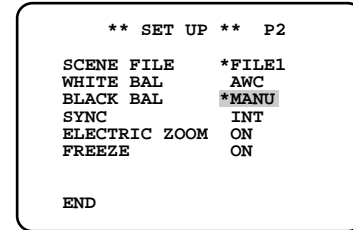

"BLACK BAL" screen

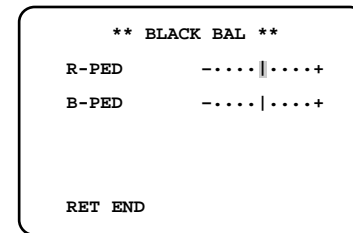

- Z Move the cursor to "BLACK BAL" and press the [SEL] button.
 - The "BLACK BAL" screen appears.
- X Mount the lens cap on the camera lens.
- C Move the cursor to "R-PED", be sure to view a vector scope or a waveform monitor when "R-PED" is adjusted with use of the [e] or [f] button. Adjustment shall be performed so that the carrier is minimized.
- V Move the cursor to "B-PED" and adjust "B-PED" with use of the [e] or [f] button while viewing a vector scope or a waveform monitor. Adjustment shall be performed so that the carrier is minimized.

10. Synchronization setting [SYNC]

The synchronization state is displayed. The horizontal phase in the external synchronization can also be adjusted. The internal synchronization is indicated as "INT", and the external synchronization is indicated as "EXT".

The horizontal phase in the external synchronization is adjusted.

Top screen of SETUP menu

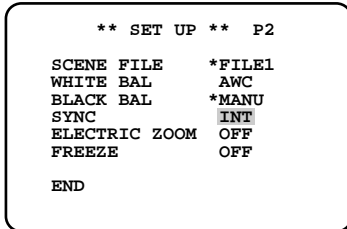

"SYNC" screen

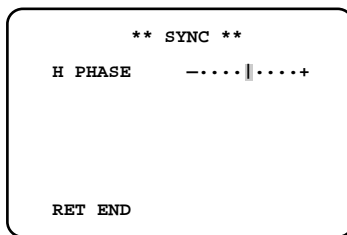

- Z Set the synchronizing signal input/output selection switch on the rear face of the CCU to "IN".
- X Connect the video synchronizing signal to the synchronizing signal output/input connector.
- C Perform the settings of the function setup switches 1 and 2 in accordance with the video format used by the device to be synchronized. (⇨ page 11)
- V Move the cursor to "SYNC" on the top screen of the SETUP menu.
- b Press the [SEL] button after making sure that "EXT" appears.
→ The "SYNC" screen appears.
- n Connect the Y or G signal from the RGB/YPbPr output connector and the video synchronizing input signal to an oscilloscope, observe the horizontal synchronization component.
- m Adjust the horizontal phase with use of the [e] or [f] button.

11. Electronic zoom setting [ELECTRIC ZOOM]

Selection "ON" (default) or "OFF" determines whether or not to use the electronic zoom.

To prevent the electronic zoom from being active by mistake, select "OFF".

When "ON" is selected, assignment of the zoom function to the [e] and [f] buttons in the SEL menu allows users to scale up (up to 2.5 times) or scale down a photographic subject with use of the [e] or [f] button.

Notes:

- Calling up the SETUP menu cancels scale up and down.
- When "ELECTRIC ZOOM" is set to "OFF", "ZOOM OFF" appears in the SEL menu, and the zoom function is not adjustable.

12. Image freezing [FREEZE]

Selection "ON" (default) or "OFF" determines whether or not to enable the freeze function.

When "ON" is selected, pressing the [FREEZE (MENU)] button on the front face of the CCU allows users to display the video currently displayed as a static image. (⇨ page 9)

■ Default setting restoring

- When the settings of the level indicators (-...|...+) in the SETUP menu or SEL menu are reset to the default, hold down both of the [e] and [f] buttons simultaneously for more than 2 seconds.
- When all the settings in the SETUP and SEL menu are reset to the default, move the cursor to "END" on the bottom line, and hold down both of the [FREEZE (MENU)] and [h] buttons simultaneously for more than 2 seconds.

SEL Menu

The SEL menu is a simplified menu that can be called up by pressing the [SEL] button while an image is displayed.

The following items can be set with use of the SEL menu.

- **Image level [BRIGHTNESS]:** Adjusts the brightness (ELC, gain (AUTO), and the convergence level of electronic sensitivity enhancement (AUTO)).
- **Red level [R-GAIN]:** Adjusts the red level.
- **Blue level [B-GAIN]:** Adjusts the blue level.
- **Edge enhancement level [DTL-LEVEL]:** Adjusts the edge enhancement level.
- **Electronic zoom [ZOOM]:** Adjusts the zoom factor.
- **Detection area [AREA]:** Specifies the detection areas of ELC, gain (AUTO), and electronic sensitivity enhancement (AUTO).

■ How to display or operate the SEL menu

- Z Press the [SEL] button.
→ The SEL menu appears.
- X Press the [SEL] button to call up the screen of the item to be changed.
- C Use of the [e] or [f] button allows users to adjust the setting.

Notes:

- Pressing the [SEL] button displays the last displayed item while the power is supplied.
- No operation for more than 3 seconds also terminates the SEL menu.

■ Button assignment

Only pressing the [e] or [f] button allows users to assign the settings in the SEL menu while an image is displayed.

How to assign settings

- Z Call up the screen of the setting to be assigned in the SEL menu to a button.
- X Hold down both of the [SEL] and [FREEZE (MENU)] buttons simultaneously while the screen is displayed until the displayed contents disappear.
- C Use the [e] or [f] button to display and assign the settings to be stored.

Note:

- If "ZOOM" is assigned to a button, zoom can be adjusted in the image freezing state (⇄ page 24).

Troubleshooting

Before asking for repairs, check the symptoms with the following table.

Contact your dealer if a problem cannot be solved even after checking and trying the solution in the table or a problem is not described below.

Symptom	Cause/solution	Reference pages
No image displayed	<ul style="list-style-type: none"> Are the cables appropriately connected to the video output connector, S-VIDEO output connector, RGB/YPbPr output connector, HDMI output connector, or SDI output connector, respectively? Check whether each cable is appropriately connected. 	11, 12
	<ul style="list-style-type: none"> Is the monitor luminance appropriately adjusted, or is the contrast appropriately adjusted? Check whether the monitor settings are appropriate. 	—
Camera with no response to the button operation on the front face of the CCU	<ul style="list-style-type: none"> Is the function setup switch No. 4 set to "ON"? Set the function setup switch No. 4 to "ON". 	11
The lighting LED of the [SCENE] button unchanged	<ul style="list-style-type: none"> Pressing once displays the state. Press the [SCENE] button repeatedly until your target LED lights. 	9
The lighting LED of the [GAIN] button unchanged	<ul style="list-style-type: none"> Pressing once displays the state. Press the [GAIN] button repeatedly until your target LED lights. 	9
Only the color bar displayed	<ul style="list-style-type: none"> Is the camera cable appropriately connected at both the connector of the CCU and the connector of the camera head? Check whether the connection is appropriately established. 	9
The hue [MATRIX] unadjustable in the menu	<ul style="list-style-type: none"> Is the camera cable appropriately connected at both the connector of the CCU and the connector of the camera head? Connection between the camera head and camera cable is required to adjust the image quality. Check whether the connection is appropriately established. 	9

Symptom	Cause/solution	Reference pages
Blurred screen	<ul style="list-style-type: none"> Is the lens aperture appropriately adjusted? Check whether the aperture is appropriately adjusted. Use lenses with recommended F number or higher and 3CCD-specific lenses. 	14
Plural edges visible	<ul style="list-style-type: none"> Try to change the setting of "DTL MODE". 	20
	<ul style="list-style-type: none"> Try to change the monitor cable. 	—
"AWC OK" not displayed	<ul style="list-style-type: none"> When the screen is too bright, narrow the lens aperture or set "ELC" to "ON". 	14, 18
Black bars at right and left of image	<ul style="list-style-type: none"> This phenomenon depends on the specifications of the monitor. Select the wide and full screen display at the monitor side. 	—
Vertically longer image	<ul style="list-style-type: none"> This unit provides outputs on the assumption that the screen is 16:9. Select the wide screen display at the monitor side. 	—
No sound from monitor	<ul style="list-style-type: none"> The monitor is not applicable to sound output. 	—

Specifications

● GP-US932CU/GP-US932CUS

Power source:	12 V DC
Power consumption:	15 W (excluding camera head)
Pick-up system:	Micro prism system
Image sensor:	1/3" 3CCD, interline transfer (IT) equipped (progressive scanning supported)
Synchronization:	Internal or external synchronization
Video output:	Video output: BNC Connector x1, 1.0 V[P-P]/75 Ω S-video output: S-video connector x1 Y: 0.714 V[P-P]/75 Ω C: 0.286 V[P-P]/75 Ω RGB/YPbPr output: D-sub 9-pin connector x1 R, G, B: 0.7 V[P-P]/75 Ω Y: 0.7 V[P-P]/75 Ω Pb, Pr: 0.525 V[P-P]/75 Ω SYNC: 0.6 V[P-P]/75 Ω (at output using 1 080i or 720p) 0.3 V[P-P]/75 Ω (at output using 480p or 480i) VIDEO: 1.0 V[P-P]/75 Ω HDMI output: HDMI connector x1 (GP-US932CU only) SDI output: BNC connector x2 (GP-US932CUS only)
Video format:	Video output: 480/59.94i S-video output: 480/59.94i RGB/YPbPr output: 1 080/59.94i, 720/59.94p, 480/59.94p, 480/59.94i HDMI output: 1 080/59.94i, 720/59.94p, 480/59.94p (GP-US932CU only) SDI output: 1 080/59.94i, 720/59.94p, 480/59.94i (GP-US932CUS only)
Required Illumination:	2 000 lx (3 200 K, F5.6)
Minimum illumination:	40 lx {0.4 footcandle} (F2.8, GAIN: HIGH, 30 % output, at center)
Signal-to-noise ratio:	54 dB (at output using 1 080i)
Horizontal resolution:	700 TV lines at center (when 1 080i output)
Color bar:	SMPTE color bar with 0 % set-up
Functions:	Camera title, ELC, electronic shutter, gain adjustment, electronic sensitivity enhancement, output signal, scene file, white balance, black balance, synchronization, electronic zoom, image freezing
External control:	RS-232C D-sub 9-pin connector x1
Ambient operating temperature:	0 °C to 40 °C {32 °F to 104 °F}
Ambient operating humidity:	30 % to 90 %
Dimensions:	GP-US932CU, GP-US932CUS: 170 (W) x 44 (H) x 229 (D) mm {6-11/16"(W) x 1-3/4"(H) x 9-1/16"(D)} (excluding rubber feet and protruding portions) GP-US932H: 37 (W) x 47 (H) x 60 (D) mm {1-7/16"(W) x 1-7/8"(H) x 2-3/8"(D)} (excluding tripod socket and protruding portions)
Weight:	GP-US932CU: 1.3 kg {2.9 lbs} GP-US932CUS: 1.45 kg {3.2 lbs} GP-US932H: 150 g {0.3 lbs}
Finish:	Ivory color coating

Dimensions and Weights indicated are approximate.

Specifications are subject to change without notice.

● GP-US932CUE/GP-US932CUSE

Power source:	12 V DC
Power consumption:	15 W (excluding camera head)
Pick-up system:	Micro prism system
Image sensor:	1/3" 3CCD, interline transfer (IT) equipped (progressive scanning supported)
Synchronization:	Internal or external synchronization
Video output:	Video output: BNC Connector x1, 1.0 V[P-P]/75 Ω
	S-video output: S-video connector x1
	Y: 0.7 V[P-P]/75 Ω
	C: 0.3 V[P-P]/75 Ω
	RGB/YPbPr output: D-sub 9-pin connector x1
	R, G, B: 0.7 V[P-P]/75 Ω
	Y: 0.7 V[P-P]/75 Ω
	Pb, Pr: 0.525 V[P-P]/75 Ω
	SYNC: 0.6 V[P-P]/75 Ω (at output using 1 080i or 720p)
	0.3 V[P-P]/75 Ω (at output using 576p or 576i)
	VIDEO: 1.0 V[P-P]/75 Ω
	HDMI output: HDMI connector x1 (GP-US932CUE only)
	SDI output: BNC connector x2 (GP-US932CUSE only)
Video format:	Video output: 576/50i
	S-video output: 576/50i
	RGB/YPbPr output: 1 080/50i, 720/50p, 576/50p, 576/50i
	HDMI output: 1 080/50i, 720/50p, 576/50p (GP-US932CUE only)
	SDI output: 1 080/50i, 720/50p, 576/50i (GP-US932CUSE only)
Required Illumination:	2 000 lx (3 200 K, F5.6)
Minimum illumination:	40 lx {0.4 footcandle} (F2.8, GAIN: HIGH, 30 % output, at center)
Signal-to-noise ratio:	54 dB (at output using 1 080i)
Horizontal resolution:	700 TV lines at center (when 1 080i output)
Color bar:	EUB color bar with 0 % set-up
Functions:	Camera title, ELC, electronic shutter, gain adjustment, electronic sensitivity enhancement, output signal, scene file, white balance, black balance, synchronization, electronic zoom, image freezing
External control:	RS-232C D-sub 9-pin connector x1
Ambient operating temperature:	0 °C to 40 °C {32 °F to 104 °F}
Ambient operating humidity:	30 % to 90 %
Dimensions:	GP-US932CUE, GP-US932CUSE: 170 (W) x 44 (H) x 229 (D) mm {6-11/16"(W) x 1-3/4"(H) x 9-1/16"(D)} (excluding rubber feet and protruding portions)
	GP-US932HE: 37 (W) x 47 (H) x 60 (D) mm {1-7/16"(W) x 1-7/8"(H) x 2-3/8"(D)} (excluding tripod socket and protruding portions)
Weight:	GP-US932CUE: 1.3 kg {2.9 lbs}
	GP-US932CUSE: 1.45 kg {3.2 lbs}
	GP-US932HE: 150 g {0.3 lbs}
Finish:	Ivory color coating

Dimensions and Weights indicated are approximate.
Specifications are subject to change without notice.

Standard Accessories

● GP-US932CU/GP-US932CUS

Operating Instructions (This document) 1 pc.

Warranty Card for U.S. Field 1 pc.

● GP-US932CUE/GP-US932CUSE

Operating Instructions (This document) 1 pc.

Optional Accessories

● GP-US932CU/GP-US932CUS

3CCD Color Camera Head GP-US932H

3CCD Color Camera Cable GP-CA932/4

3CCD Color Camera Cable GP-CA932/6

● GP-US932CUE/GP-US932CUSE

3CCD Color Camera Head GP-US932HE

3CCD Color Camera Cable GP-CA932/4E

3CCD Color Camera Cable GP-CA932/6E

Information on Disposal for Users of Waste Electrical & Electronic Equipment (private households)

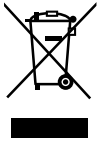

This symbol on the products and/or accompanying documents means that used electrical and electronic products should not be mixed with general household waste.

For proper treatment, recovery and recycling, please take these products to designated collection points, where they will be accepted on a free of charge basis. Alternatively, in some countries you may be able to return your products to your local retailer upon the purchase of an equivalent new product.

Disposing of this product correctly will help to save valuable resources and prevent any potential negative effects on human health and the environment which could otherwise arise from inappropriate waste handling. Please contact your local authority

for further details of your nearest designated collection point.

Penalties may be applicable for incorrect disposal of this waste, in accordance with national legislation.

For business users in the European Union

If you wish to discard electrical and electronic equipment, please contact your dealer or supplier for further information.

Information on Disposal in other Countries outside the European Union

This symbol is only valid in the European Union.

If you wish to discard this product, please contact your local authorities or dealer and ask for the correct method of disposal.

For U.S., Canadian and Puerto Rican fields:

Panasonic System Solutions Company,
Unit Company of Panasonic Corporation of North America
www.panasonic.com/business/
For customer support, call 1.800.528.6747
Three Panasonic Way 2H-2, Secaucus, New Jersey 07094

Panasonic Canada Inc.
5770 Ambler Drive, Mississauga,
Ontario, L4W 2T3 Canada (905)624-5010
<http://www.panasonic.ca>

Panasonic Sales Company
Division of Panasonic Puerto Rico Inc.
San Gabriel Industrial Park 65th Infantry Ave. KM. 9.5 Carolina
P.R. 00985(809)750-4300

For European and other fields:

Matsushita Electric Industrial Co., Ltd.
Osaka, Japan
<http://panasonic.net>

Importer's name and address to follow EU rules:

Panasonic Testing Centre
Panasonic Services Europe GmbH
Winsbergring 15, 22525 Hamburg F.R.Germany