

# INSTALLATION INSTRUCTIONS

## STELLAR

### AIR CONDITIONING UNIT SPLIT-SYSTEM COOLING

#### CONTENTS

GENERAL .....	2
NOMENCLATURE .....	2
SAFETY .....	2
INSPECTION .....	2
LIMITATIONS .....	2
LOCATION .....	3
GROUND INSTALLATION .....	3
ROOF INSTALLATION .....	3
UNIT PLACEMENT .....	3
VERIFY INDOOR REFRIGERANT ORIFICE .....	4
INSTALLATIONS REQUIRING TXV .....	4
PIPING CONNECTIONS .....	5
PRECAUTIONS DURING LINE INSTALLATION .....	5
PRECAUTIONS DURING BRAZING OF LINES .....	6
PRECAUTIONS DURING BRAZING ANGLE VALVE .....	6 & 7
GENERAL INFORMATION & GROUNDING .....	8
FIELD CONNECTIONS POWER WIRING .....	8
FIELD CONNECTIONS CONTROL WIRING .....	8
SYSTEM CHARGE .....	8
MEASUREMENT METHOD .....	9
SUPERHEAT CHARGING METHOD .....	9
SYSTEM START-UP .....	9
ENERGIZE CRANKCASE HEATER .....	9
SYSTEM CONTROLLER - HDB076 ONLY .....	13
INSTRUCTING THE OWNER .....	13
INDICATIONS OF PROPER OPERATION .....	13
MAINTENANCE .....	13



**MODELS:**    **10 SEER**            **H\*DB012 - 76**  
                  **11 SEER**            **H\*DE024 - 60**  
                  **12 SEER**            **H\*DH018 - 60**  
                  **50 Hz**                **H\*DA018-076**

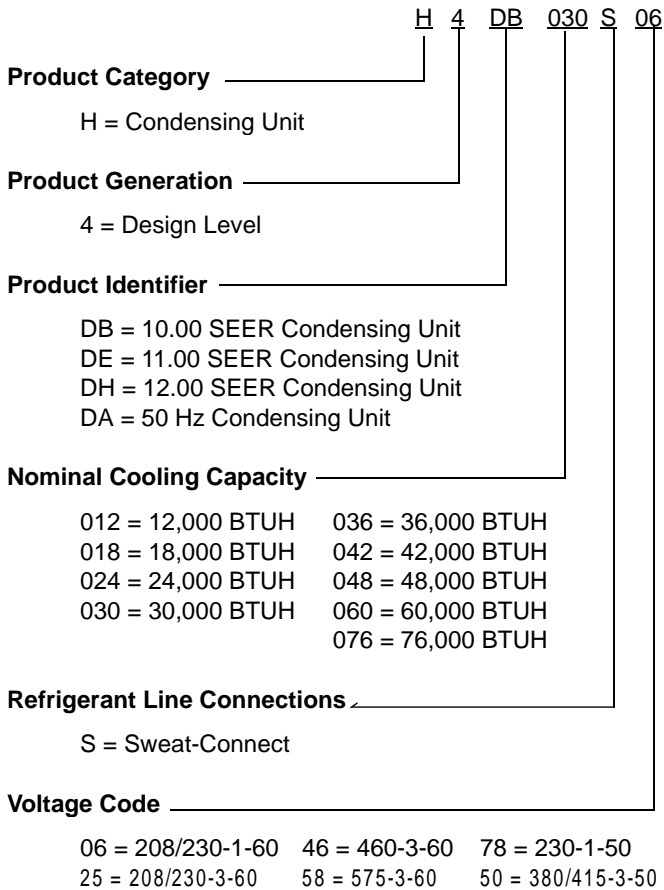
**CAUTION: READ ALL SAFETY GUIDES BEFORE  
YOU BEGIN TO INSTALL YOUR UNIT.**

SAVE THIS MANUAL

**GENERAL**

This instruction covers the installation of the following Stellar air conditioning units.

**NOMENCLATURE**



Installer should pay particular attention to the words: NOTE, CAUTION and WARNING.

NOTES are intended to clarify or make the installation easier.

CAUTIONS are given to prevent equipment damage.

WARNINGS are given to alert the installer that personal injury and/or equipment damage may result if installation procedures are not handled properly..

*This product must be installed in strict compliance with the enclosed installation instructions and any applicable local, state, and national codes including, but not limited to, building, electrical, and mechanical codes.*

*Incorrect installation may create a condition where the operation of the product could cause personal injury or property damage.*

**INSPECTION**

As soon as a unit is received, it should be inspected for possible damage during transit. If damage is evident, the extent of the damage should be noted on the carrier's freight bill. A separate request for inspection by the carrier's agent should be made in writing. See Form 50.15-NM for more information.

**LIMITATIONS**

The unit should be installed in accordance with all national and local safety codes and the limitations listed below:

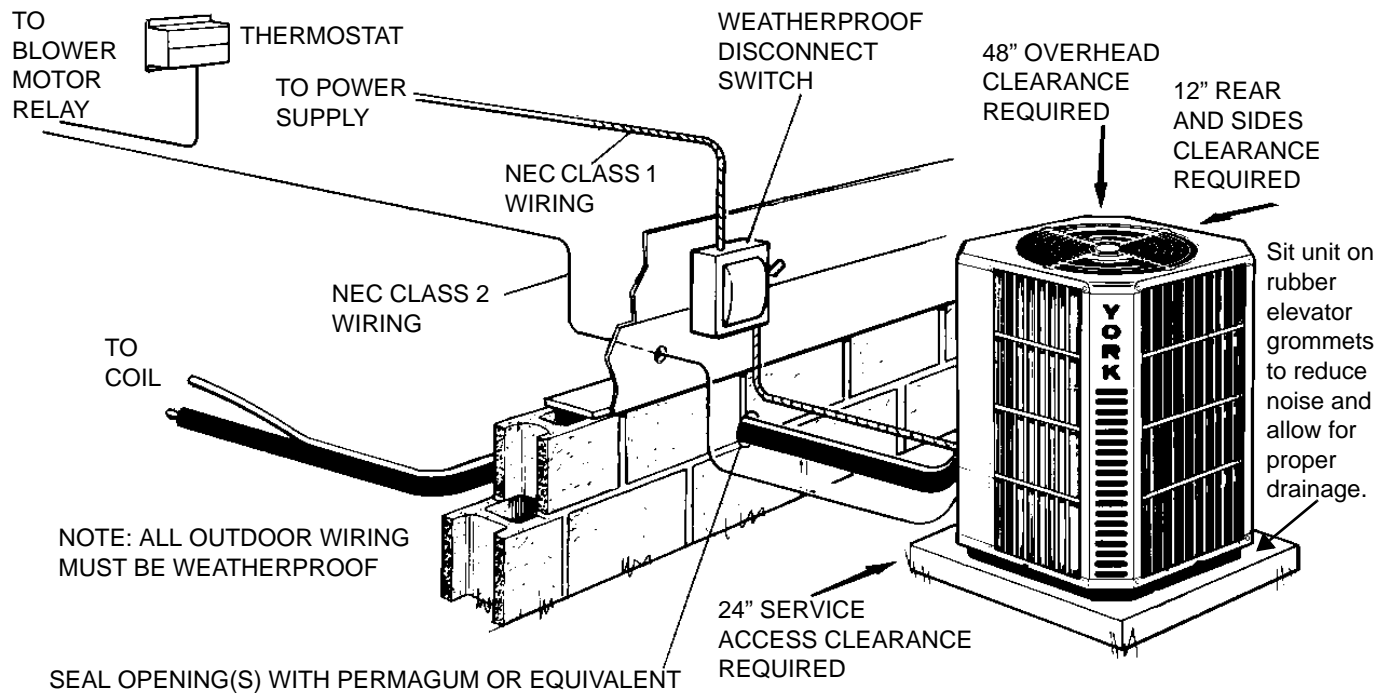
1. Limitations for the indoor unit, coil and appropriate accessories must also be observed.
2. The outdoor unit must not be installed with any duct work in the air stream. The outdoor fan is the propeller type and is not designed to operate against any additional external static pressure.
3. The unit should not be operated at outdoor temperatures below 45 °F.
4. Indoor evaporator coil orifice ***must be removed prior to*** the installation of a TXV kit if the system match requires a TXV.

These outdoor units are designed to be connected to a matching UPG indoor coil with sweat connection lines. These units are factory charged with refrigerant for a matching indoor coil plus 15 feet of field supplied line. The outside unit is designed to be placed alongside or at the back of the home, remote from the indoor coil. The outdoor unit has been factory run-tested and all components of the system are ready for easy, immediate installation.

Matching evaporators contain an orifice liquid feed sized for the most common usage. The orifice size and/or refrigerant charge may need to be changed for some indoor-outdoor unit combinations, elevation differences or total line lengths.

**SAFETY**

Use this instruction in conjunction with the instruction for the appropriate indoor evaporator coil, variable speed air handler or furnace and other accessories. Read all instructions before installing the unit.



**FIGURE 1: TYPICAL INSTALLATION**

**LOCATION**

Before starting the installation, select and check the suitability of the location for both the indoor and outdoor unit. Observe all limitations and clearance requirements.

The outdoor unit must have sufficient clearance for air entrance to the condenser coil, for air discharge and for service access. See Figure 1.

If the unit is to be installed on a hot sun exposed roof or a black-topped ground area, the unit should be raised sufficiently above the roof or ground to avoid taking the accumulated layer of hot air into the outdoor unit.

Provide an adequate structural support.

**GROUND INSTALLATION**

The unit may be installed at ground level on a solid base that will not shift or settle, causing strain on the refrigerant lines and possible leaks. Maintain the clearances shown in Figure 1 and install the unit in a level position. Isolate the base from the structure to avoid noise or vibration transmission.

Isolate the unit from rain gutters to avoid any possible wash out of the foundation.

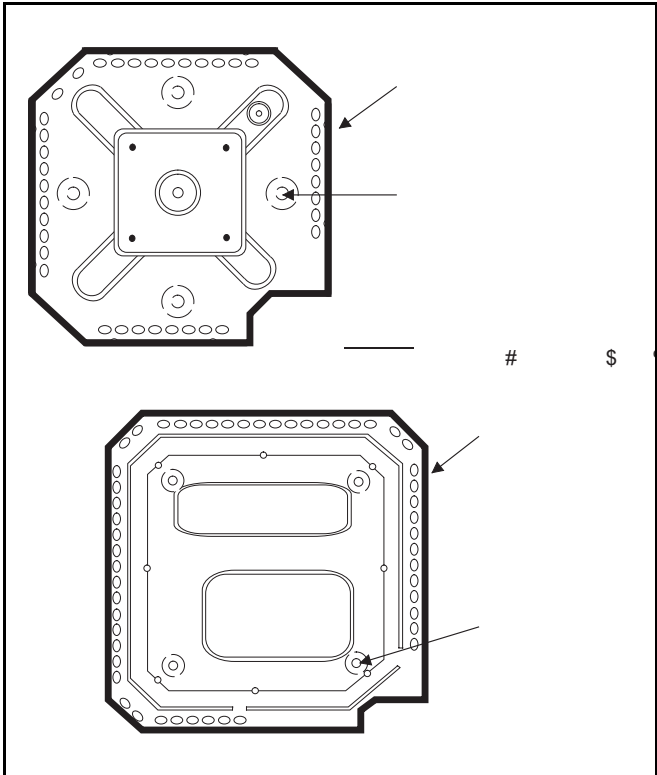
Normal operating sound levels may be objectionable if the unit is placed directly under windows of certain rooms (bedrooms, study, etc.).

**ROOF INSTALLATION**

When installing units on a roof, the structure must be capable of supporting the total weight of the unit, including a pad, lintels, rails, etc., which should be used to minimize the transmission of sound or vibration into the conditioned space.

**UNIT PLACEMENT**

1. Provide a base in the pre-determined location.
2. Remove the shipping carton and inspect for possible damage.
3. Compressor tie-down bolts should remain tightened.
4. Position the unit on the base provided.
5. Sit unit on the (4) rubber elevating grommets if provided. Use grommet kit 1SG0601 if not provided. These should be positioned as shown in Figure 2 to reduce noise and allow for proper drainage.
6. Make a hole(s) in the structure wall large enough to accommodate the insulated vapor line, the liquid line and the wiring.

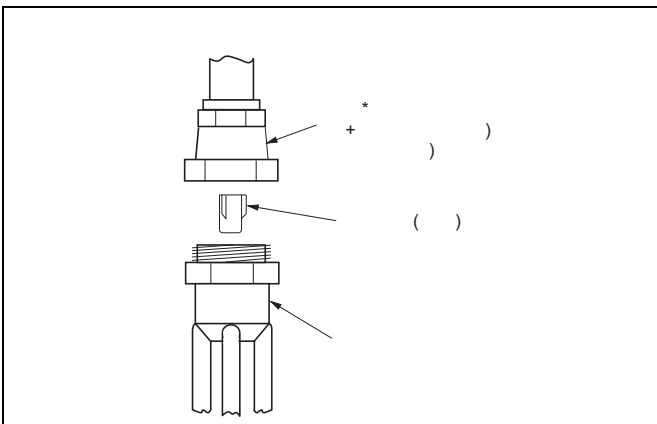


**FIGURE 2 : POSITIONING GROMMETS**

**VERIFY INDOOR REFRIGERANT ORIFICE**

Refer to the Tabular Data Sheet for the outdoor unit model and installed evaporator coil. Determine the correct orifice for that combination.

If the orifice sizes match, nothing further is required and the refrigerant lines may be connected per the outdoor unit instruction. However, if another orifice should be used, change the orifice in the coil with the following procedure:



**FIGURE 3 : ORIFICE INSTALLATION**

**⚠ WARNING**

*Coil is under 30 PSIG helium pressure. Relieve pressure from schrader valve on liquid line side.*

**⚠ CAUTION**

*This fitting is a right-hand thread, turn counter-clockwise to remove.*

1. First, relieve the holding charge by depressing the Schrader valve located in the end of the liquid line.
2. Remove the liquid line fitting using 3/4" wrenches, and remove the pre-installed orifice with a small diameter wire or paper clip.
3. Remove the new orifice from the packet and verify that it is the correct number required. Install this orifice with the rounded end toward the coil and the flat end outward per Figure 3 on page 4.
4. Thread the liquid line fitting back in place on the coil. Tighten the fitting hand tight and turn an additional 1/8 turn to seal.

**⚠ CAUTION**

*Use 3/4" wrenches to turn fittings. Using pliers will cause internal damage to the fitting.*

**NOTE:** *This procedure should be done within 2 minutes to keep air and contaminants from entering the coil. If the orifice cannot be replaced and the coil resealed within 2 minutes, then it should be temporarily closed to air using masking tape (short term delay) or plugging/capping (long term delay). There is no need to purge the coil if this procedure is done within the time limit.*

5. Mark the data plate of the coil with the orifice installed.

**INSTALLATIONS REQUIRING TXV**

For installations requiring a TXV, the following are the basic steps for installation. For detailed instructions, refer to the Installation Instructions accompanying the TXV kit.

Install TXV kit as follows:

1. First, relieve the holding charge by depressing the Schrader valve located in the end of the liquid line.

**⚠ WARNING**

*The evaporator coil is under 30 psig pressure.*

2. After holding charge is completely discharged, loosen and remove the liquid line fitting from the orifice distributor assembly. Note that the fitting has **right hand threads**.
3. Remove the orifice from the distributor body using a small diameter wire or paper clip. Orifice is not used when the TXV assembly is installed.
4. After orifice is removed, install the thermal expansion valve to the orifice distributor assembly with supplied fittings. Hand tighten and turn an additional 1/8 turn to seal. Do not overtighten fittings.
5. Reinstall the liquid line to the top of the thermal expansion valve. Hand modify the liquid line to align with casing opening.
6. Install the TXV equalizer line into the vapor line as follows:
  - a. Select a location on the vapor line for insertion of the equalizer line which will not interfere with TXV bulb placement.
  - b. Use an awl to punch through the suction tube and insert the awl to a depth to achieve a 1/8 inch diameter hole.
7. Install TXV equalizer line in 1/8 hole previously made in vapor line. Equalizer line can be bottomed out in vapor line as end of equalizer line is cut on 45 degrees angle to prevent blockage. Braze equalizer line making sure that tube opening is not brazed closed.

**⚠ CAUTION**

*Dry nitrogen should always be supplied through the tubing while it is being brazed, because the temperature required is high enough to cause oxidation of the copper unless an inert atmosphere is provided. The flow of dry nitrogen should continue until the joint has cooled. Always use a pressure regulator and safety valve to insure that only low pressure dry nitrogen is introduced into the tubing. Only a small flow is necessary to displace air and prevent oxidation.*

All connections to be brazed are copper-to-copper and should be brazed with a phosphorous-copper alloy material such as Silfos-5 or equivalent. DO NOT use soft solder.

Install the TXV bulb to the vapor line near the equalizer line, using the two bulb clamps furnished with the TXV assembly.

Ensure the bulb is making maximum contact. Refer to TXV installation instruction for view of bulb location.

**⚠ CAUTION**

*In all cases, mount the TXV bulb after vapor line is brazed and has had sufficient time to cool.*

- a. Bulb should be installed on a horizontal run of the vapor line if possible. On lines under 7/8" OD the bulb may be installed on top of the line. With 7/8" OD and over, the bulb should be installed at the position of about 4 or 8 o'clock.
- b. If bulb installation is made on a vertical run, the bulb should be located at least 16 inches from any bend, and on the tubing sides opposite the plane of the bend. On vertical bulb installations, the bulb should be positioned with the bulb tail at the top, so that the bulb acts as a reservoir.
- c. Bulb should be insulated using thermal insulation provided to protect it from the effect of the surrounding ambient temperature.

**PIPING CONNECTIONS**

The outdoor condensing unit may be connected to the indoor evaporator coil using field supplied refrigerant grade copper tubing that is internally clean and dry. Units should be installed only with the tubing sizes for approved system combinations as specified in Tabular Data Sheet. The charge given is applicable for total tubing lengths up to 15 feet. See Application Data Form 690.01-AD1V for installing tubing of longer lengths and elevation differences.

**NOTE:** *Using a larger than specified line size could result in oil return problems. Using too small a line will result in loss of capacity and other problems caused by insufficient refrigerant flow. Slope horizontal vapor lines at least 1" every 20 feet toward the outdoor unit to facilitate proper oil return.*

**PRECAUTIONS DURING LINE INSTALLATION**

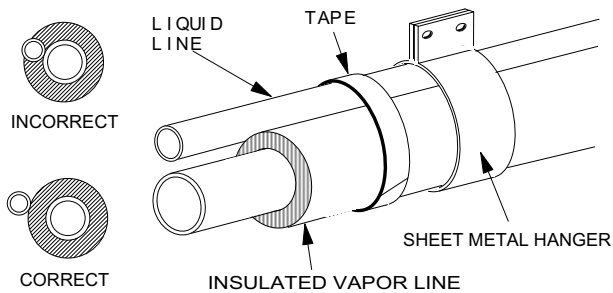
1. Install the lines with as few bends as possible. Care must be taken not to damage the couplings or kink the tubing. Use clean hard drawn copper tubing where no appreciable amount of bending around obstruction is necessary. If soft copper must be used, care must be taken to avoid sharp bends which may cause a restriction.
2. The lines should be installed so that they will not obstruct service access to the coil, air handling system or filter.
3. Care must also be taken to isolate the refrigerant lines to minimize noise transmission from the equipment to the structure.



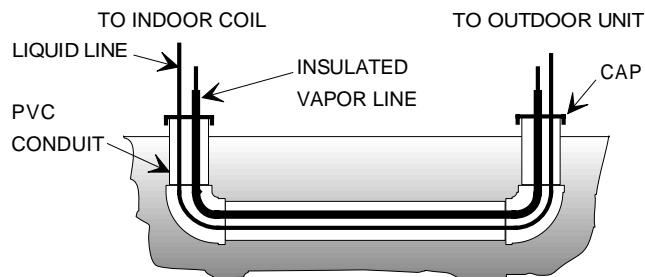
4. The vapor line must be insulated with a minimum of 1/2" foam rubber insulation (Arm-A-Flex or equivalent). Liquid lines that will be exposed to direct sunlight and/or high temperatures must also be insulated.

Tape and suspend the refrigerant lines as shown. DO NOT allow metal-to-metal contact. See Figure 4.

5. Use PVC piping as a conduit for all underground installations as shown in Figure 5. Buried lines should be kept as short as possible to minimize the build up of liquid refrigerant in the vapor line during long periods of shut-down.



**FIGURE 4 : TUBING HANGER**



**FIGURE 5 : UNDERGROUND INSTALLATION**

6. Pack fiber glass insulation and a sealing material such as permagum around refrigerant lines where they penetrate a wall to reduce vibration and to retain some flexibility.
7. See Form 690.01-AD1V for additional piping information.

#### PRECAUTIONS DURING BRAZING OF LINES

All outdoor unit and evaporator coil connections are copper-to-copper and should be brazed with a phosphorous-copper alloy material such as Silfos-5 or equivalent. DO NOT use soft solder.

#### CAUTION

*Dry nitrogen should always be supplied through the tubing while it is being brazed, because the temperature required is high enough to cause oxidation of the copper unless an inert atmosphere is provided. The flow of dry nitrogen should continue until the joint has cooled. Always use a pressure regulator and safety valve to insure that only low pressure dry nitrogen is introduced into the tubing. Only a small flow is necessary to displace air and prevent oxidation.*

The outdoor units have re-usable service valves on both the liquid and vapor connections. The total system refrigerant charge is retained within the outdoor unit during shipping and installation. The re-usable service valves are provided to evacuate and charge per this instruction.

Serious service problems can be avoided by taking adequate precautions to assure an internally clean and dry system.

#### PRECAUTIONS DURING BRAZING ANGLE VALVE

Precautions should be taken to prevent heat damage to angle valve by wrapping a wet rag around it as shown in Figure 6. Also, protect all painted surfaces and insulation during brazing. After brazing - cool joint with wet rag.

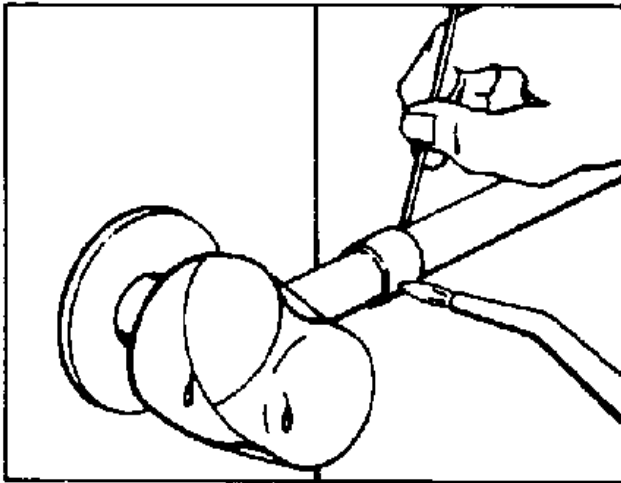
#### WARNING

*This is not a backseating valve. The service access port has a valve core. Opening or closing valve does not close service access port.*

*If the valve stem is backed out past the retaining ring, the O-ring can be damaged causing leakage or system pressure could force the valve stem out of the valve body possibly causing personal injury. In the event the retaining ring is missing, do not attempt to open the valve.*

Connect the refrigerant lines using the following procedure:.

1. Remove the cap and Schrader core from both the liquid and vapor angle valve service ports at the outdoor unit. Connect low pressure nitrogen to the liquid line service port.
2. Braze the liquid line to the liquid valve at the outdoor unit. Be sure to wrap the valve body with a wet rag. Allow the nitrogen to continue flowing.



**FIGURE 6 : HEAT PROTECTION**

**CAUTION**

*If visual verification of the valve stem reaching the retaining ring is impossible, stop backing out the valve stem when the slightest increase in resistance is felt. Because of the small size and therefore the reduced resistance, back out the liquid valve 5 turns maximum to prevent going past the retaining ring.*

3. Carefully remove the brazed plugs from the evaporator liquid and vapor connections after relieving the pressure in the evaporator.

**CAUTION**

*The evaporator is pressurized.*

4. Braze the liquid line to the evaporator liquid connection. The nitrogen should now be flowing through the evaporator coil.
5. Slide the grommet away from the vapor connection at the coil. Braze the vapor line to the evaporator vapor connection. After the connection has cooled, slide the grommet back into original position.
6. Protect the vapor valve of the outdoor unit with a wet rag and braze the vapor line connection. The nitrogen flow should be exiting the system from the vapor service port connection. After this connection has cooled, remove the nitrogen source from the liquid fitting service port.

7. Replace the schrader cores in the liquid and vapor valves.
8. Evacuate the vapor line, evaporator and the liquid line, to 500 microns or less.
9. Leak test all refrigerant piping connections including the service port flare caps to be sure they are leak tight. **DO NOT OVERTIGHTEN** (between 40 and 60 inch - lbs. maximum).

**NOTE:** Do not use the system refrigerant in the outdoor unit to purge or leak test.

10. Replace caps on service ports. Do not remove the flare caps from the service ports except when necessary for servicing the system.

**CAUTION**

*Do not connect manifold gauges unless trouble is suspected. Approximately 3/4 ounce of refrigerant will be lost each time a standard manifold gauge is connected.*

11. Release the refrigerant charge into the system. Open both the liquid and vapor valves by removing the plunger cap and with an allen wrench back out counter-clockwise until valve stem just touches retaining ring. Release the refrigerant charge into the system. See "PRECAUTIONS DURING BRAZING ANGLE VALVE" on page 6.

Replace plunger cap finger tight, then tighten an additional 1/12 turn (1/2 hex flat). Cap must be replaced to prevent leaks.

If a leak is suspected, leak test to locate the leak. To verify the leak, close the valve to the vacuum pump suction to isolate the pump and hold the system under vacuum. If the micron gauge indicates a steady and continuous rise after a few minutes, it's an indication of a leak. If the gauge shows a rise, then levels off after a few minutes and remains fairly constant, its an indication that the system is leak free, but still contains moisture and may require further evacuation if the reading is above 1000 microns.

12. If the refrigerant tubing, indoor evaporator coil or outdoor condensing unit has developed a leak during shipment, or was, for any other reason, opened to the atmosphere for more than four (4) minutes, it is necessary to evacu-

ate the system down to at least 500 microns to eliminate contamination and moisture in the system.

### ⚠ WARNING

*Never attempt to repair any brazed connections while the system is under pressure. Personal injury could result.*

See “SYSTEM START-UP” on page 9 for checking and recording system charge.

## GENERAL INFORMATION & GROUNDING

Check the electrical supply to be sure that it meets the values specified on the unit nameplate and wiring label.

Power wiring, control (low voltage) wiring, disconnect switches and over current protection to be supplied by the installer. Wire size should be sized per NEC requirements.

### ⚠ CAUTION

*All field wiring must USE COPPER CONDUCTORS ONLY and be in accordance with Local, National Fire, Safety & Electrical Codes. This unit must be grounded with a separate ground wire in accordance with the above codes.*

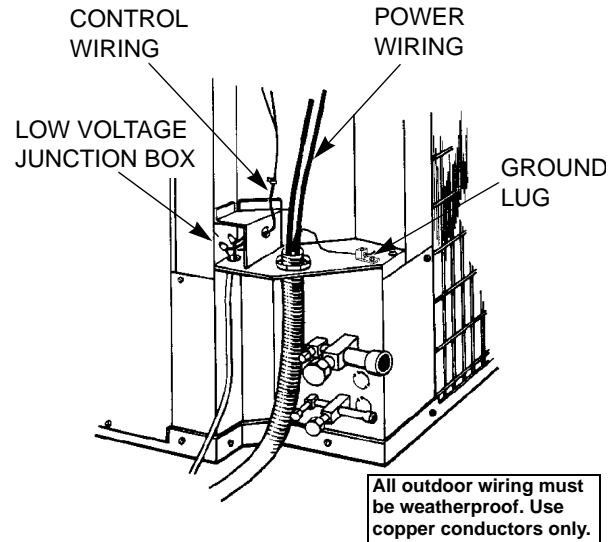
The complete connection diagram and schematic wiring label is located on the inside surface of the unit electrical box cover and this instruction.

## FIELD CONNECTIONS POWER WIRING

1. Install the proper size weatherproof disconnect switch outdoors and within sight of the unit.
2. Run power wiring from the disconnect switch to the unit.
3. Remove the control box cover to gain access to the unit wiring. Route wires from disconnect through power wiring opening provided and into the unit control box as shown in Figure 7.
4. Install the proper size time-delay fuses or circuit breaker, and make the power supply connections.
5. Energize the crankcase heater to save time by preheating the compressor oil while the remaining installation is completed.

## FIELD CONNECTIONS CONTROL WIRING

1. Route low voltage wiring into bottom of control box as shown in Figure 7. Make low voltage wiring connections inside the junction box per Figures 8, 9, 10 or 11.



**FIGURE 7 : TYPICAL FIELD WIRING**

2. The complete connection diagram and schematic wiring label is located on the inside surface of the unit electrical box cover.
3. All field wiring to be in accordance with national electrical codes (NEC) and/or local-city codes.

**NOTE:** A Start Assist Kit is available and recommended for long line set applications or in areas of known low voltage problems. A hard start kit must be used if a solenoid valve accessory or non-bleed type expansion device is installed.

4. Mount the thermostat about 5 ft. above the floor, where it will be exposed to normal room air circulation. Do not place it on an outside wall or where it is exposed to the radiant effect from exposed glass or appliances, drafts from outside doors or supply air grilles.
5. Route the 24-volt control wiring (NEC Class 2) from the outdoor unit to the indoor unit and thermostat.

**NOTE:** To eliminate erratic operation, seal the hole in the wall at the thermostat with permagum or equivalent to prevent air drafts affecting the anticipators in the thermostat.

## SYSTEM CHARGE

The factory charge in the outdoor unit includes enough charge for the unit and a most sold matched evaporator. Some indoor coil matches may require some additional charge. See Tabular Data sheet provided in unit literature packet.

Sweat connect units also include sufficient charge for 15 feet of lines. See Tabular Data for charge adder for line lengths greater than 15 feet.



The "TOTAL SYSTEM CHARGE" must be permanently stamped on the unit data plate.


Total system charge is determined as follows:

1. Determine outdoor unit charge from tabular data sheet.
2. Determine indoor coil adjustment from tabular data sheet.
3. Calculate the line charge using the Tabular Data Sheet.
  - a. Calculate total length of pre-charged lines for quick connect units.
  - b. Calculate over 15 feet of sweat lines for sweat connect units.

**NOTE:** *The charge for pre-charged lines should be included in the system charge shown on the data plate but need not be added to the system. If sweat connect lines are used, the line charge over 15 feet should be included on the data plate and must be added to the system.*

4. Total system charge = item 1 + item 2 + item 3.
5. Permanently stamp the unit data plate with the total amount of refrigerant in the system.


Use one of the following charging methods whenever additional refrigerant is required for the system charge.



*Refrigerant charging should only be carried out by a qualified air conditioning contractor.*

**Measurement Method**

If a calibrated charging cylinder or accurate weighing device is available, add refrigerant accordingly.



*Compressor damage will occur if system is improperly charged. On new system installations charge system per tabular data sheet for the matched coil and follow guidelines in this instruction.*

Check flare caps on service ports to be sure they are leak tight. DO NOT OVERTIGHTEN (between 40 and 60 inch - lbs. maximum).

**Superheat Charging Method**

**NOTE:** *Use this method only during system maintenace and repair.*

1. Operate system until temperatures and pressures stabilize (minimum of 10 minutes).
2. Measure and record indoor wet bulb (WB) temperature using a sling psychrometer and the outdoor dry bulb (DB) temperature using a thermometer.
3. Measure and record the suction pressure at the suction service valve port.
4. Using Table 1 on page 12, note the superheat value corresponding to the intersection of the indoor wet bulb and the outdoor dry bulb.
5. With the superheat value obtained in step 4 and the suction pressure value from step 3, find the intersection of the values in Table 2 on page 12. This is the required suction tube temperature at the suction service valve.
6. To bring the tube temperature in line with the required value from Table 2, add refrigerant to the service port to cause the tube temperature to fall and reclaim refrigerant to cause the temperature to rise.

Check flare caps on Schrader fittings to be sure they are tight. DO NOT OVERTIGHTEN (40-60 inch-lbs. maximum).

**SYSTEM START-UP**

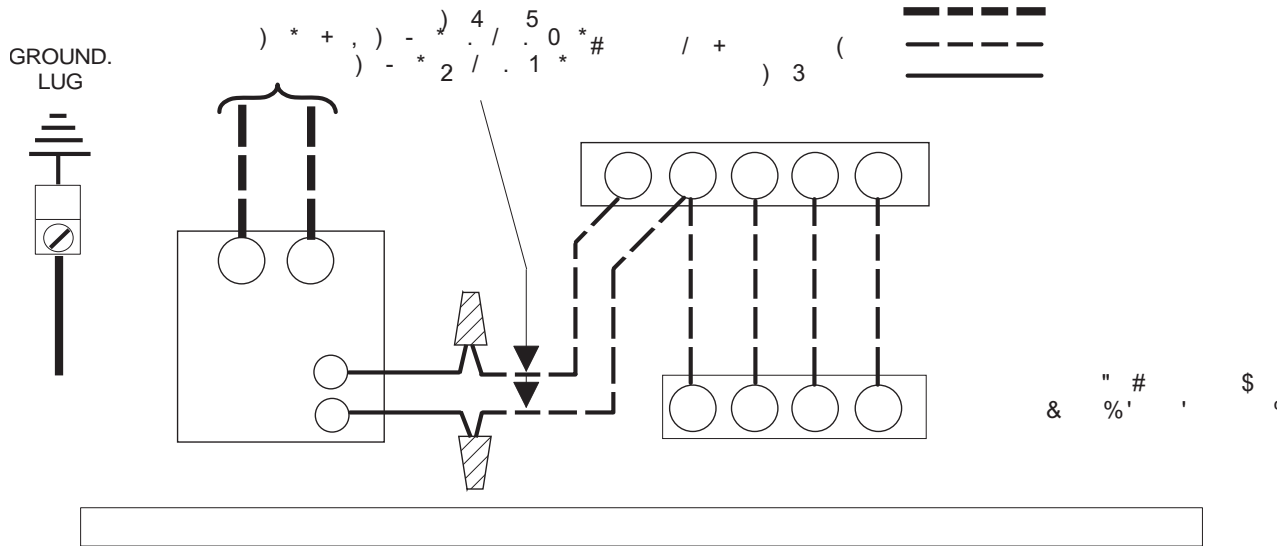
**ENERGIZE CRANKCASE HEATER**

If this unit is equipped with a crankcase heater for the compressor, a warning label with an adhesive back is supplied in the unit installation instruction packet. This label should be attached to the field supplied disconnect switch where it will be easily seen. See below:

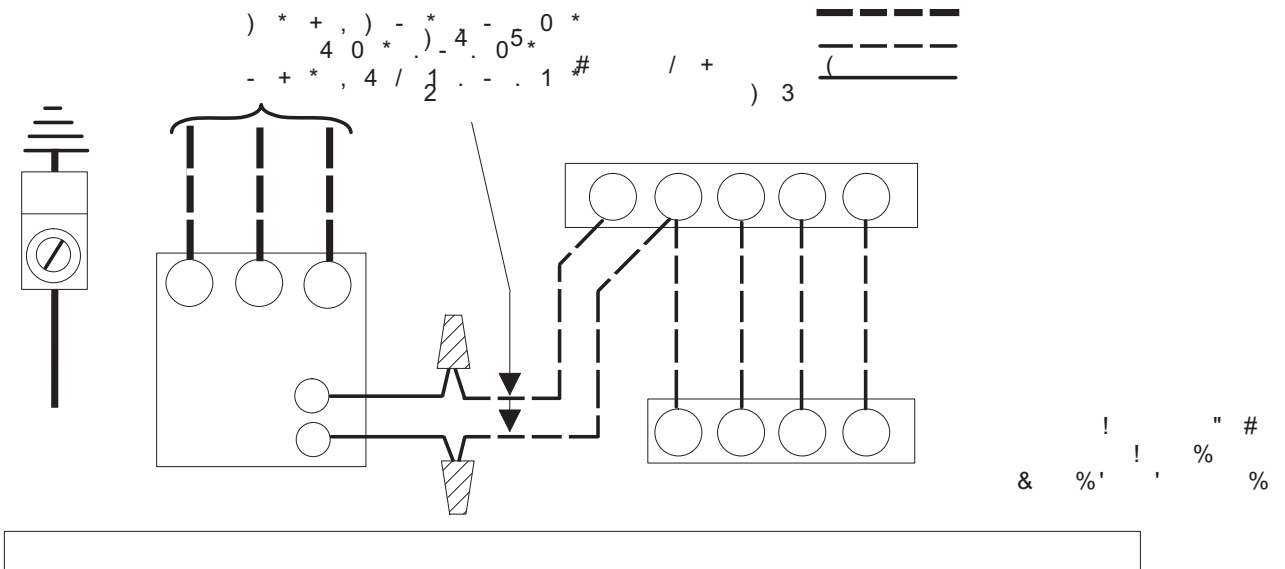
In order to energize the crankcase heater:- Set indoor two stage cooling thermostat to "OFF" position.- Close the line power disconnect to the unit.

**IMPORTANT**

*An attempt to start the compressor without at least 8 hours of crankcase heat will damage the compressor*

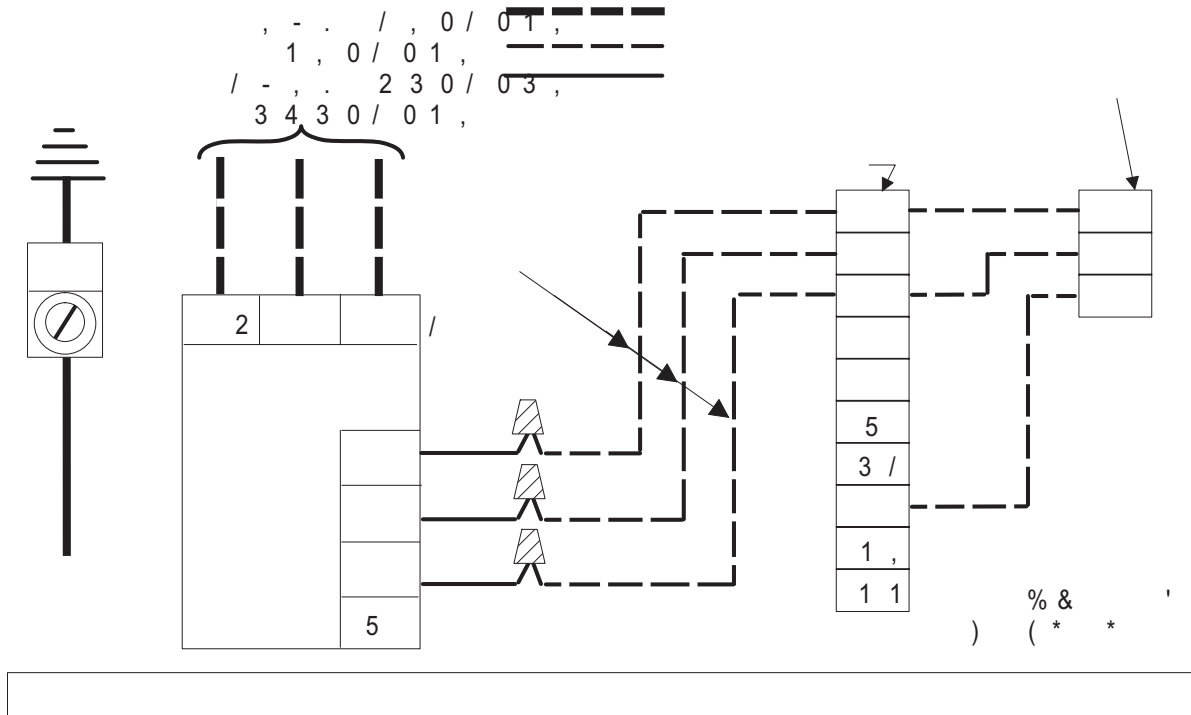


**FIGURE 8 : TYPICAL SINGLE PHASE FIELD WIRING**



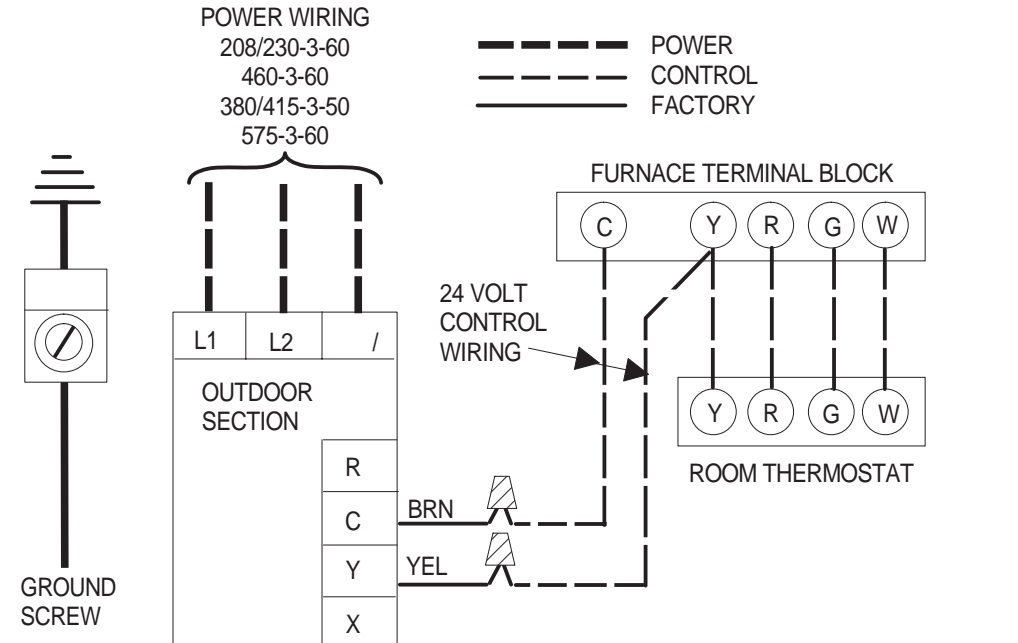
**FIGURE 9 : TYPICAL THREE PHASE FIELD WIRING**

ALL FIELD WIRING TO BE IN ACCORDANCE WITH NATIONAL ELECTRICAL CODE (NEC) AND/OR LOCAL CODES



**FIGURE 10 : TYPICAL FIELD WIRING - AIR HANDLER (H\*DB076 & H\*DA076 ONLY)**

ALL FIELD WIRING TO BE IN ACCORDANCE WITH NATIONAL ELECTRICAL CODE (NEC) AND/OR LOCAL CODES



**FIGURE 11 : TYPICAL FIELD WIRING - FURNACE (H\*DB076 & H\*DA076 ONLY)**

**Table 1: SUPERHEAT VALUE**

INDOOR WB °F <sup>1</sup>	OUTDOOR DB°F												
	55	60	65	70	75	80	85	90	95	100	105	110	115
50	9	7											
52	12	10	6										
54	14	12	10	7									
56	17	15	14	10	6								
58	20	18	16	13	9	5							
60	23	21	19	16	12	8	6						
62	26	24	22	19	16	12	8	5					
64	29	27	24	21	18	15	11	9	6				
66	32	31	30	24	23	18	15	11	9	6			
68	35	33	30	27	24	21	19	16	14	12	9	6	
70		35	33	30	28	25	22	20	18	15	13	11	8
72			35	33	30	28	26	24	20	20	17	15	14
74				34	31	30	27	25	23	22	20	18	
76					35	33	31	29	27	26	25	23	

<sup>1</sup>: Evaporator Entering Air °F

**Table 2: TEMPERATURE AND PRESSURE**

SUCTION PRESSURE PSIG (SERVICE PORT)	SUCTION SERVICE VALVE SUPERHEAT °F																	
	0 <sup>1</sup>	2	4	6	8	10	12	14	16	18	20	22	24	26	28	30	32	34
61.5	35	37	39	41	43	45	47	49	51	53	55	57	59	61	63	65	67	69
64.2	37	39	41	43	45	47	49	51	53	55	57	59	61	63	65	67	69	71
67.1	39	41	43	45	47	49	51	53	55	57	59	61	63	65	67	69	71	73
70.0	41	43	45	47	49	51	53	55	57	59	61	63	65	67	69	71	73	75
73.0	43	45	47	49	51	53	55	57	59	61	63	63	67	69	71	73	75	77
76.0	45	47	49	51	53	55	57	59	61	63	65	67	69	71	73	75	77	79
79.2	47	49	51	53	55	57	59	61	63	65	67	69	71	73	75	77	79	81
82.4	49	51	53	55	57	59	61	63	65	67	69	71	73	75	77	79	81	83

<sup>1</sup>: Saturation Temperature

**Table 3: R-22 SATURATION PROPERTIES**

TEMP. °F	PRESSURE PSIG	TEMP. °F	PRESSURE PSIG	TEMP. °F	PRESSURE PSIG	TEMP. °F	PRESSURE PSIG	TEMP. °F	PRESSURE PSIG
45	76.02	60	101.62	75	132.22	90	168.40	105	210.75
46	77.58	61	103.49	76	134.45	91	171.02	106	213.81
47	79.17	62	105.39	77	136.71	92	173.67	107	216.90
48	80.77	63	107.32	78	138.99	93	176.35	108	220.02
49	82.39	64	109.26	79	141.30	94	179.06	109	223.17
50	84.03	65	111.23	80	143.63	95	181.80	110	226.35
51	85.69	66	113.22	81	145.99	96	184.56	111	229.56
52	87.38	67	115.24	82	148.37	97	187.36	112	232.80
53	89.08	68	117.28	83	150.78	98	190.18	113	236.08
54	90.81	69	119.34	84	153.22	99	193.03	114	239.38
55	92.56	70	121.43	85	155.68	100	195.91	115	242.72
56	94.32	71	123.54	86	158.17	101	198.82	116	246.10
57	96.11	72	125.67	87	160.69	102	201.76	117	249.50
58	97.93	73	127.83	88	163.23	103	204.72	118	252.94
59	99.76	74	130.01	89	165.80	104	207.72	119	256.41

## SYSTEM CONTROLLER - HDB076 ONLY

Controls operation as follows:

1. **RANDOM START** - Upon initial application of power and a 2.5 second time delay, the compressor contactor will be energized.
2. **ANTI-SHORT CYCLE** - Once the unit is energized, a momentary interruption of power, i.e., thermostat cycling, greater than 8 milliseconds, will initiate the compressor lockout time delay of five minutes regardless of the condition of the inputs. Upon completion of the 5 minute lockout delay the system will automatically reset allowing the compressor contactor to energize.
3. **SAFETY SWITCH** - Upon interruption of power to the compressor via the high pressure or low pressure switch, the compressor contactor will be locked out indefinitely. Reset will occur when the pressure switch recloses and power has been removed and reapplied via the system circuit breaker or by cycling the thermostat temperature setting from maximum cool to maximum heat and back to desired cool setting. During lockout the fault indicating lamp shall be on.
4. **LOW PRESSURE SWITCH BY-PASS TIME DELAY** - The low pressure switch is by-passed for a period of 75 - 105 seconds to allow the system to start and stabilize. After the delay period has expired the system will then be maintained by the low pressure switch. In the event that the low pressure switch should open after the delay period while the compressor is running the system will go into lockout. Note depending upon how the system is wired the lockout may automatically be reset or may require a manual reset.

System Time Delays are as follows: Random Start = 2.5 seconds; Lockout = 5 minutes; Low Pressure By-pass = 75 - 105 seconds.

## INSTRUCTING THE OWNER

Assist owner with processing warranty cards. Review Owners Guide and provide a copy for the owner guidance on proper operation and maintenance. Instruct the owner or the operator how to start, stop and adjust temperature setting.

When applicable, instruct the owner that the compressor is equipped with a crankcase heater to prevent the migration of refrigerant to the compressor during the "OFF" cycle. The heater is energized only when the unit is not running. If the main switch is disconnected for long periods of shut down, do not attempt to start the unit until 8 hours after the switch has been connected. This will allow sufficient time for all liquid refrigerant to be driven out of the compressor.

The installer should also instruct the owner on proper operation and maintenance of all other system components.

## INDICATIONS OF PROPER OPERATION

Cooling operation is the same as any conventional air conditioning unit.

The following checks may be made to determine if the system is operating properly:

1. The outdoor fan should be running, with warm air being discharged from the top of the unit.
2. The indoor blower (furnace or air handler) will be operating, discharging cool air from the ducts.
3. The vapor line at the outdoor unit will feel cool to the touch.
4. The liquid line at the outdoor unit will feel warm to the touch.

If unit is not operating properly, check the following items before calling a serviceman:

1. Indoor section for dirty filter.
2. Outdoor section for leaf or debris blockage.

Eliminate problem, turn off the thermostat for 10 seconds and attempt start. Wait 5 minutes. If system does not start, call service technician.

## MAINTENANCE

1. Dirt should not be allowed to accumulate on the outdoor coils or other parts in the air circuit. Clean as often as necessary to keep the unit clean. Use a brush, vacuum cleaner attachment, or other suitable means.
2. The outdoor fan motor is permanently lubricated and does not require periodic oiling.
3. If the coil needs to be cleaned, it should be washed with Calgon CalClean (mix one part CalClean to seven parts water). Allow solution to remain on coil for 30 minutes before rinsing with clean water. Solution should not be permitted to come in contact with painted panel surfaces.
4. Refer to the furnace or air handler instructions for filter and blower motor maintenance.
5. The evaporator coil drain pan should be inspected and cleaned regularly to prevent odors and assure proper drainage.

WHEN THE SYSTEM IS FUNCTIONING PROPERLY AND THE OWNER HAS BEEN FULLY INSTRUCTED, SECURE THE OWNER'S APPROVAL.



**NOTES:**

**NOTES:**

**NOTES:**