

# 12" Compound Miter Saw

(Model 36-255)

INSTRUCTION MANUAL

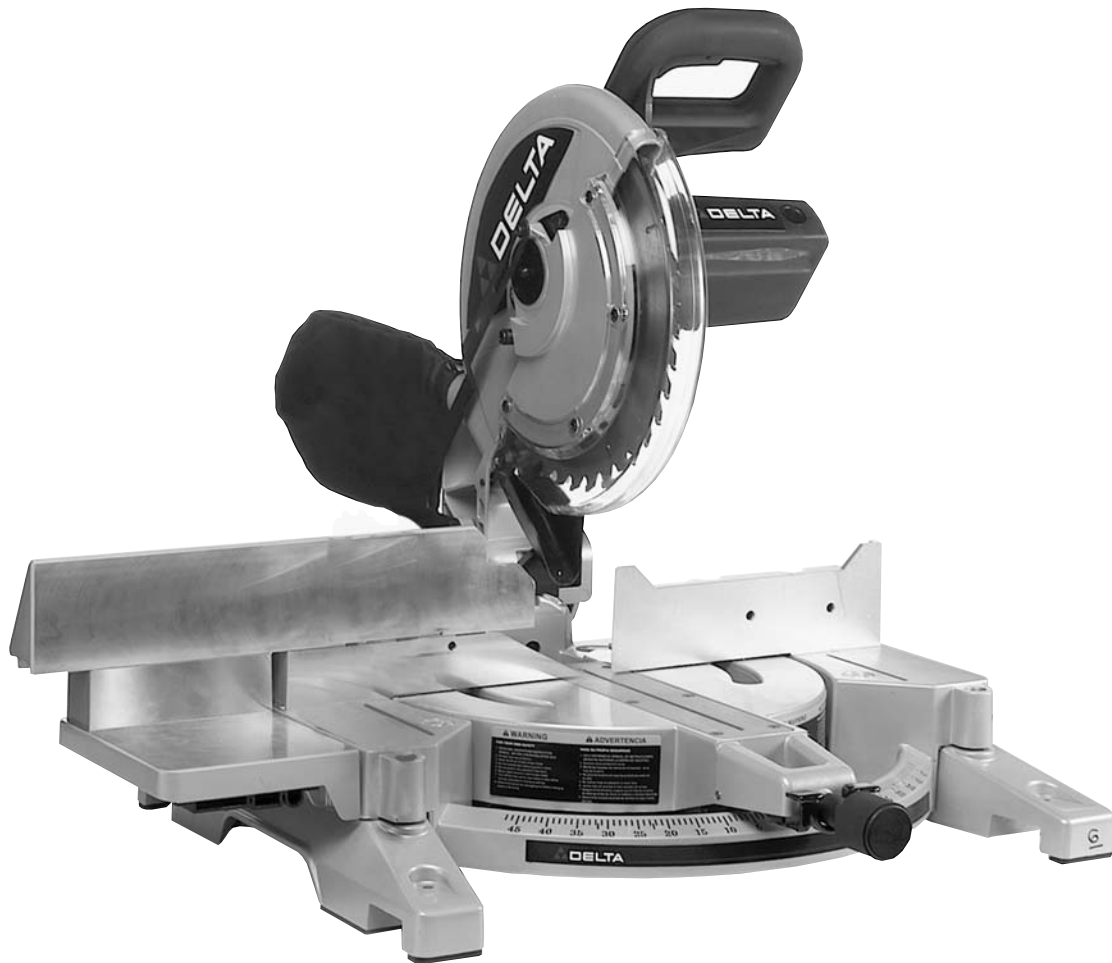

PART NO. 899943 - 05-31-01  
Copyright © 2001 Delta Machinery



To learn more about DELTA MACHINERY  
visit our website at: [www.deltamachinery.com](http://www.deltamachinery.com).

For Parts, Service, Warranty or other Assistance,

please call **1-800-223-7278** (In Canada call **1-800-463-3582**).

**ESPAÑOL: PÁGINA 21**

# GENERAL SAFETY RULES

Woodworking can be dangerous if safe and proper operating procedures are not followed. As with all machinery, certain hazards are involved with the operation of the product. Using the machine with respect and caution will considerably lessen the possibility of personal injury. However, if normal safety precautions are overlooked or ignored, personal injury to the operator may result. Safety equipment such as guards, push sticks, hold-downs, featherboards, goggles, dust masks and hearing protection can reduce your potential for injury. But even the best guard won't make up for poor judgment, carelessness or inattention. Always use common sense and exercise caution in the workshop. If a procedure feels dangerous, don't try it. Figure out an alternative procedure that is safer. **REMEMBER:** Your personal safety is your responsibility.

This machine was designed for certain applications only. DO NOT modify and/or use it for any application other than that for which it was designed. If you have any questions relative to a particular application, **DO NOT** use the machine until you have first contacted Delta to determine if it can or should be performed on the product.

**Technical Service Manager  
Delta Machinery  
4825 Highway 45 North  
Jackson, TN 38305**

(IN CANADA: 505 SOUTHGATE DRIVE, GUELPH, ONTARIO N1H 6M7)

## **WARNING: FAILURE TO FOLLOW THESE RULES MAY RESULT IN SERIOUS PERSONAL INJURY**

1. **FOR YOUR OWN SAFETY, READ INSTRUCTION MANUAL BEFORE OPERATING THE TOOL.** Learn the tool's application and limitations as well as the specific hazards peculiar to it.

2. **KEEP GUARDS IN PLACE** and in working order.

3. **ALWAYS WEAR EYE PROTECTION.** Wear safety glasses. Everyday eyeglasses only have impact resistant lenses; they are not safety glasses. Also use face or dust mask if cutting operation is dusty. These safety glasses must conform to ANSI Z87.1 requirements. Note: Approved glasses have Z87 printed or stamped on them.

4. **REMOVE ADJUSTING KEYS AND WRENCHES.** Form habit of checking to see that keys and adjusting wrenches are removed from tool before turning it "on".

5. **KEEP WORK AREA CLEAN.** Cluttered areas and benches invite accidents.

6. **DON'T USE IN DANGEROUS ENVIRONMENT.** Don't use power tools in damp or wet locations, or expose them to rain. Keep work area well-lighted.

7. **KEEP CHILDREN AND VISITORS AWAY.** All children and visitors should be kept a safe distance from work area.

8. **MAKE WORKSHOP CHILDPROOF** – with padlocks, master switches, or by removing starter keys.

9. **DON'T FORCE TOOL.** It will do the job better and be safer at the rate for which it was designed.

10. **USE RIGHT TOOL.** Don't force tool or attachment to do a job for which it was not designed.

11. **WEAR PROPER APPAREL.** No loose clothing, gloves, neckties, rings, bracelets, or other jewelry to get caught in moving parts. Non-slip footwear is recommended. Wear protective hair covering to contain long hair.

12. **SECURE WORK.** Use clamps or a vise to hold work when practical. It's safer than using your hand and frees both hands to operate tool.

13. **DON'T OVERREACH.** Keep proper footing and balance at all times.

14. **MAINTAIN TOOLS IN TOP CONDITION.** Keep tools sharp and clean for best and safest performance. Follow instructions for lubricating and changing accessories.

15. **DISCONNECT TOOLS** before servicing and when changing accessories such as blades, bits, cutters, etc.

16. **USE RECOMMENDED ACCESSORIES.** The use of accessories and attachments not recommended by Delta may cause hazards or risk of injury to persons.

17. **REDUCE THE RISK OF UNINTENTIONAL STARTING.** Make sure switch is in "OFF" position before plugging in power cord. In the event of a power failure, move switch

to the "OFF" position.

18. **NEVER STAND ON TOOL.** Serious injury could occur if the tool is tipped or if the cutting tool is accidentally contacted.

19. **CHECK DAMAGED PARTS.** Before further use of the tool, a guard or other part that is damaged should be carefully checked to ensure that it will operate properly and perform its intended function – check for alignment of moving parts, binding of moving parts, breakage of parts, mounting, and any other conditions that may affect its operation. A guard or other part that is damaged should be properly repaired or replaced.

20. **DIRECTION OF FEED.** Feed work into a blade or cutter against the direction of rotation of the blade or cutter only.

21. **NEVER LEAVE TOOL RUNNING UNATTENDED. TURN POWER OFF.** Don't leave tool until it comes to a complete stop.

22. **STAY ALERT, WATCH WHAT YOU ARE DOING, AND USE COMMON SENSE WHEN OPERATING A POWER TOOL. DO NOT USE TOOL WHILE TIRED OR UNDER THE INFLUENCE OF DRUGS, ALCOHOL, OR MEDICATION.** A moment of inattention while operating power tools may result in serious personal injury.

23. **MAKE SURE TOOL IS DISCONNECTED FROM POWER SUPPLY** while motor is being mounted, connected or re-connected.

24. **THE DUST GENERATED** by certain woods and wood products can be injurious to your health. Always operate machinery in well ventilated areas and provide for proper dust removal. Use wood dust collection systems whenever possible.

25.  **WARNING: SOME DUST CREATED BY POWER SANDING, SAWING, GRINDING, DRILLING, AND OTHER CONSTRUCTION ACTIVITIES** contains chemicals known to cause cancer, birth defects or other reproductive harm. Some examples of these chemicals are:

- lead from lead-based paints,
  - crystalline silica from bricks and cement and other masonry products, and
  - arsenic and chromium from chemically-treated lumber.
- Your risk from these exposures varies, depending on how often you do this type of work. To reduce your exposure to these chemicals: work in a well ventilated area, and work with approved safety equipment, such as those dust masks that are specially designed to filter out microscopic particles.

**SAVE THESE INSTRUCTIONS. Refer to them often and use them to instruct others.**

## ADDITIONAL SAFETY RULES FOR COMPOUND MITER SAWS

- 1. WARNING: USE ONLY CROSS-CUTTING SAW BLADES. DO NOT USE BLADES WITH DEEP GULLETS AS THEY CAN DEFLECT AND CONTACT THE GUARD.**
- 2. WARNING:** Do not operate the miter saw until it is completely assembled and installed according to the instructions.
- 3. IF YOU ARE NOT** thoroughly familiar with the operation of compound miter saws, obtain advice from your supervisor, instructor or other qualified person.
- 4. BE SURE** blade is sharp, runs freely and is free of vibration.
- 5. ALLOW** the motor to come up to full speed before starting cut.
- 6. KEEP** motor air slots clean and free of chips.
- 7. ALWAYS MAKE SURE** rotating table is tight before cutting, even if the table is positioned in one of the positive stops.
- 8. BE SURE** blade and flanges are clean and that arbor screw is tightened securely.
- 9. USE ONLY** blade flanges specified for your saw.
- 10. NEVER** apply lubricants to the blade when it is running.
- 11. ALWAYS CHECK** the blade for cracks or damage before operation. Replace cracked or damaged blade immediately.
- 12. ALWAYS KEEP** the lower blade guard in place and operating properly.
- 13. MAKE SURE** blade is not contacting workpiece before switch is turned on.
- 14. NEVER LOCK** the switch in the "ON" position.
- 15. IMPORTANT:** After completing cut, release power switch and wait for coasting blade to stop before returning saw to raised position.
- 16. DO NOT** remove jammed or cut-off pieces until blade has stopped.
- 17. NEVER** cut ferrous metals or masonry.
- 18. NEVER** recut small pieces.
- 19. PROVIDE ADEQUATE SUPPORT** to the sides of the saw table for long workpieces.
- 20. NEVER** use the miter saw in an area with flammable liquids or gases.
- 21. NEVER USE SOLVENTS TO CLEAN PLASTIC PARTS.** Solvents could possibly dissolve or otherwise damage the material. Only a soft, damp cloth should be used to clean plastic parts.
- 22. DISCONNECT SAW** from power source and clean the machine before leaving it.
- 23. MAKE SURE** the work area is cleaned before leaving the machine.
- 24. ADDITIONAL INFORMATION** regarding the safe and proper operation of this product is available from the National Safety Council, 1121 Spring Lake Drive, Itasca, IL 60143-3201, in the Accident Prevention Manual for Industrial Operation and also in the Safety Data Sheets provided by the NSC. Please also refer to the American National Standard Institute ANSI 01.1 Safety Requirements for the Woodworking Machinery and the U.S. Department of Labor OSHA 1910.213 Regulations.
- 25. SOME WOOD CONTAINS PRESERVATIVES WHICH CAN BE TOXIC.** Take extra care to prevent inhalation and skin contact when working with these materials. Request, and follow, any safety information available from your material supplier.
- 26. DON'T ABUSE CORD.** Never carry tool by cord or yank it to disconnect from receptacle. Keep cord from heat, oil, and sharp edges. Have damaged or worn power cord and strain reliever replaced immediately. **DO NOT ATTEMPT TO REPAIR POWER CORD.**
- 27. WEAR EAR PROTECTION** to safeguard against possible hearing loss.
- 28. AVOID CUTTING NAILS AND KNOTS.** Inspect for and remove all nails from lumber before cutting. Try to do layout cuts between knots.
- 29. NEVER USE LIQUID COOLANT.** To do so could present electrical shock hazard.
- 30. KEEP CLEAR OF SAWDUST EJECTION CHUTE.** Sawdust and chips are expelled out the ejection chute at rear of saw. Do not allow anyone in this area while saw is in operation.
- 31. WHEN THE MITER SAW IS NOT IN USE,** the switch should be locked in the OFF position to prevent unauthorized use of the saw.

## REPLACEMENT PARTS

When servicing, use only identical replacement parts.

**POLARIZED PLUGS:** To reduce the risk of electric shock, this equipment has a polarized plug (one blade is wider than the other). This plug will fit in a polarized outlet only one way. If the plug does not fit fully in the outlet, reverse the plug. If it still does not fit, contact a qualified electrician to install the proper outlet. Do not change the plug in any way.

## MOTOR

Many Delta tools will operate on either D.C., or single phase 25 to 60 cycle A.C. current and voltage within plus or minus 5 percent of that shown on the specification plate of the tool. Several models, however, are designed for A.C. current only. Refer to the specification plate on your tool for proper voltage and current rating.

**CAUTION:** Do not operate your tool on a current where the voltage is not within correct limits. Do not operate tools rated A.C. on a D.C. current. To do so may seriously damage the tool.

## EXTENSION CORD SELECTION

Use proper extension cords. Make sure your extension cord is in good condition. When using an extension cord, be sure to use one heavy enough to carry the current of the saw. An undersized cord will cause a drop in line voltage, resulting in loss of power and overheating. Fig. 1, shows the correct gauge to use depending on the cord length. If in doubt, use the next heavier gauge. The smaller the gauge number, the heavier the cord.

### RECOMMENDED EXTENSION CORD SIZES FOR USE WITH STATIONARY ELECTRIC TOOLS

<b>MINIMUM GAUGE EXTENSION CORD</b>			
RECOMMENDED SIZES FOR USE WITH STATIONARY ELECTRIC TOOLS			
<b>Ampere Rating</b>	<b>Volts</b>	<b>Total Length of Cord in Feet</b>	<b>Gauge of Extension Cord</b>
0-6	120	up to 25	18 AWG
0-6	120	25-50	16 AWG
0-6	120	50-100	16 AWG
0-6	120	100-150	14 AWG
6-10	120	up to 25	18 AWG
6-10	120	25-50	16 AWG
6-10	120	50-100	14 AWG
6-10	120	100-150	12 AWG
10-12	120	up to 25	16 AWG
10-12	120	25-50	16 AWG
10-12	120	50-100	14 AWG
10-12	120	100-150	12 AWG
12-16	120	up to 25	14 AWG
12-16	120	25-50	12 AWG
12-16	120	GREATER THAN 50 FEET NOT RECOMMENDED	

Fig. 1

## OPERATING INSTRUCTIONS

### FOREWORD

Delta Model 36-255 is a high capacity 12" compound miter saw designed to cut wood and non-ferrous metals. It can crosscut 8" x 2¼" and 7" x 3¼", miter at 45 both left and right 5¼" x 2¼", bevel at 45 left 6¼" x 2¼" and 8" x 1¼", and compound 45 x 45, 5¼" x 2 1/2" and 4¼" x 2¼". It has positive miter stops at 0, 15, 22.5, 31.62, and 45 degrees both left and right, and bevel stops at 0 and 45 degrees left.

### POWER CONNECTIONS

A separate electrical circuit should be used for your tools. This circuit should not be less than #12 wire and should be protected with a 20 Amp time lag fuse. If an extension cord is used, use only 3-wire extension cords which have 3-prong grounding type plugs and 3-hole receptacles which accept the tool's plug. Before connecting the motor to the power line, make sure the switch is in the "OFF" position and be sure that the electric current is of the same characteristics as indicated on the tool. All line connections should make good contact. Running on low voltage will damage the motor.

## UNPACKING

1. Carefully remove the machine from the carton. Retain all packing materials until you have inspected and satisfactorily operated the machine.

**WARNING: Do not connect the machine to the power source until you have read and understood this entire instruction manual.**

2. Place the machine on a firm, level surface with extra room for handling and proper support of the workpiece.

3. Familiarize yourself with all features and controls explained in this manual.

4. The machine is shipped with the cuttinghead locked in the down position and the table rotated to 45 degrees left, Fig. 2. To release the head and move it to the operating position, see **“MOVING CUTTINGHEAD TO THE UP POSITION”** and **“MOVING THE TABLE TO THE 90 DEGREE CUT-OFF POSITION”** in this section.

5. Unassembled items are shown in Fig. 3 for identification and use in assembling the saw.

- 1 Extension table
- 2 Fence slide
- 3 Fence slide support
- 4 Dust bag
- 5 Arbor and fence wrench
- 6 1/4" wrench
- 7 Open end wrench
- 8 Lock handle for slide fence
- 9 1/4" flat washer
- 10 1/4" lock washer
- 11 1/4 - 18 x 1 1/4" long hex head screw (2)
- 12 1/4 - 18 x 3/4" long hex head screws (2)



Fig. 2

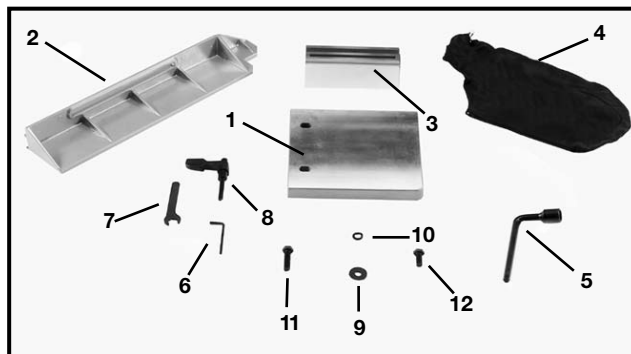

Fig. 3

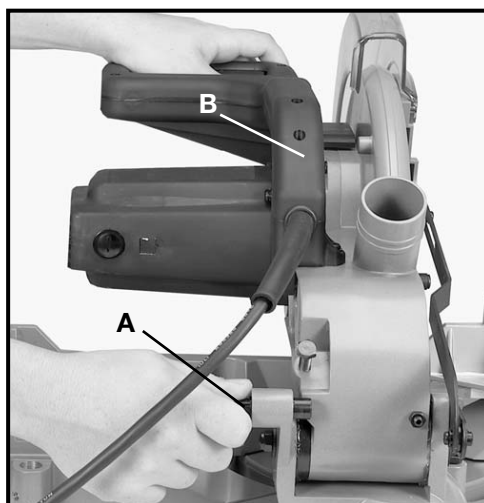

Fig. 4

## ASSEMBLY

**WARNING: FOR YOUR OWN SAFETY, DO NOT CONNECT THE MITER SAW TO THE POWER SOURCE UNTIL THE MACHINE IS COMPLETELY ASSEMBLED AND YOU HAVE READ AND UNDERSTOOD THE ENTIRE OWNER'S MANUAL.**

### MOVING CUTTINGHEAD TO THE UP POSITION

1. Pull out cuttinghead lockpin (A) Fig. 4, and move the cuttinghead (B) to the up position.

2. Fig. 5, illustrates the lockpin (A) pulled out and the cuttinghead (B) in the up position.

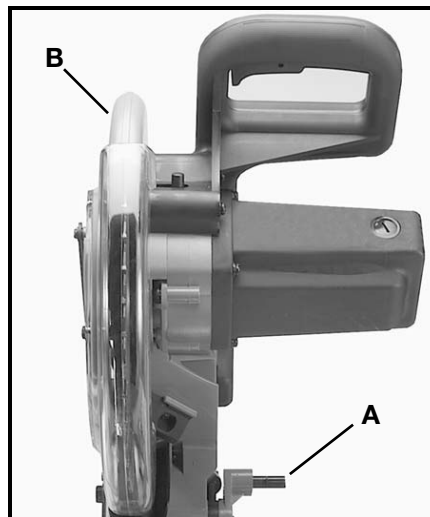

Fig. 5

## MOVING TABLE TO THE 0 DEGREE CUT-OFF POSITION

1. Rotate locking knob (A) Fig. 6 counter-clockwise as far as it will go. Depress lever (B) and rotate table (C) to the 0 degree straight cut-off position, release lever (B), and tighten locking knob (A).
2. Fig. 7 illustrates the table (C) in the 0 degree straight cut-off position.
3. For proper operation and adjustment of the table, refer to sections, “ROTATING TABLE FOR MITER CUTTING”, “ADJUSTING CLAMPING ACTION OF TABLE LOCKING MECHANISM” and “ADJUSTING SLIDING FIT BETWEEN MOVABLE TABLE AND BASE.”

## ATTACHING EXTENSION TABLE AND FENCE SLIDE

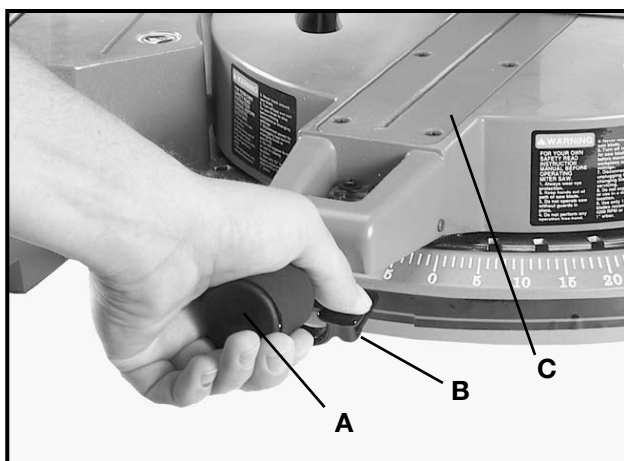

Fig. 6

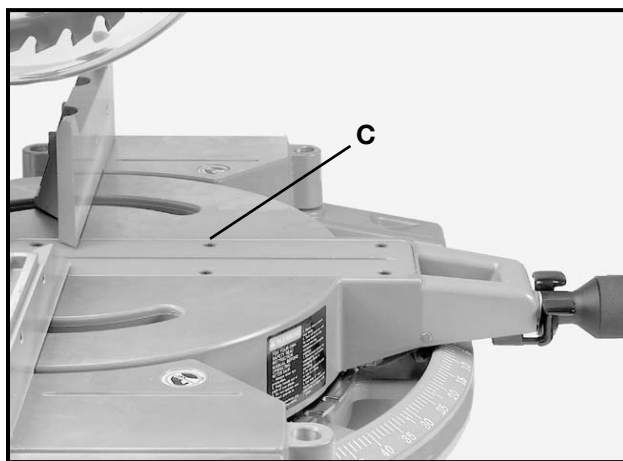

Fig. 7

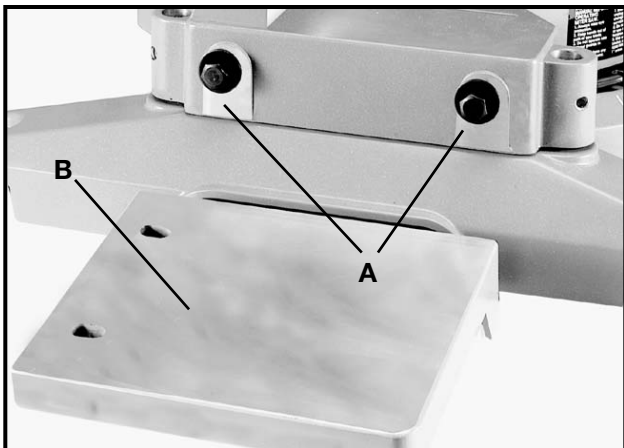

Fig. 7A

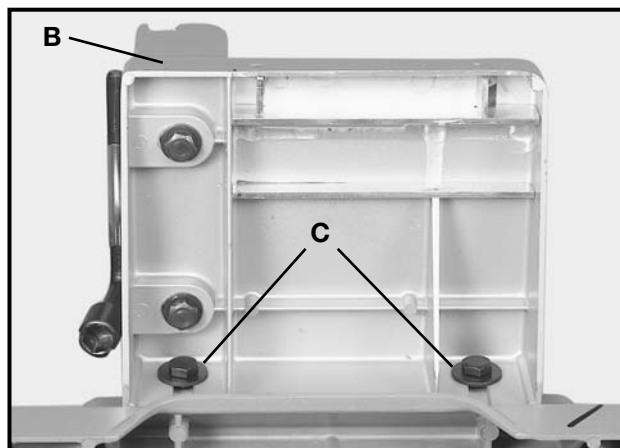

Fig. 7B

1. Attach flat washers to the two 3/4" screw assemblies (A) Fig. 7A, and thread into the threaded holes on left side of the saw.

**NOTE:** Turn the screws only a few threads into the holes at this time.

2. Attach the table extension (B) Figs. 7A and 7B, to left side of saw table, making sure groove of table extension (B) is inside flat washers (C) as shown in Fig. 7B.
3. Use a straight edge (C) Fig. 7C, to make the extension table (B) even with saw table (D), and tighten the two screws (A) Fig. 7B.

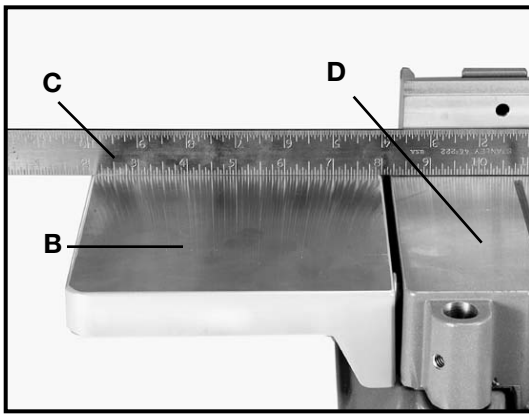

Fig. 7C

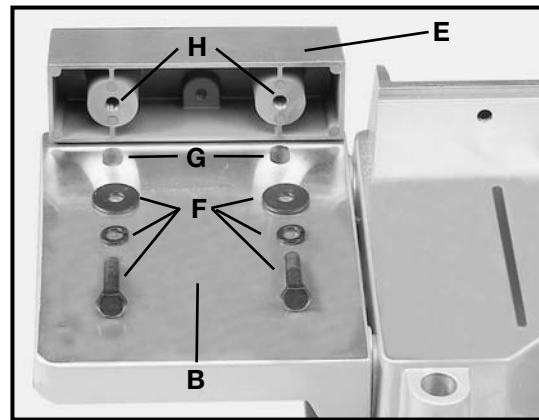

Fig. 7D

4. Attach the fence slide support (E) Fig. 7D, to the extension table (B) by using the two 1 1/4" long hex head screws, 5/16" lockwashers and 5/16" flat washers (F). Bring screws up through the two holes (G) in table extension and thread them into the two threaded holes (H) on bottom of fence slide support.

**NOTE:** Do not completely tighten screws at this time.

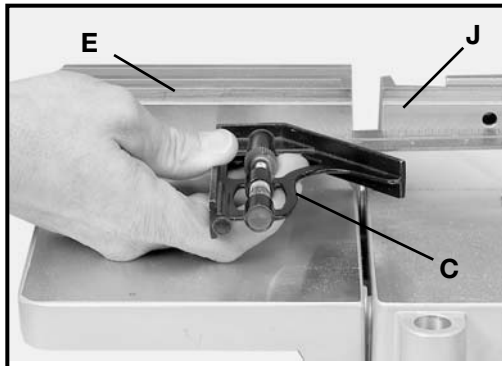

Fig. 7E

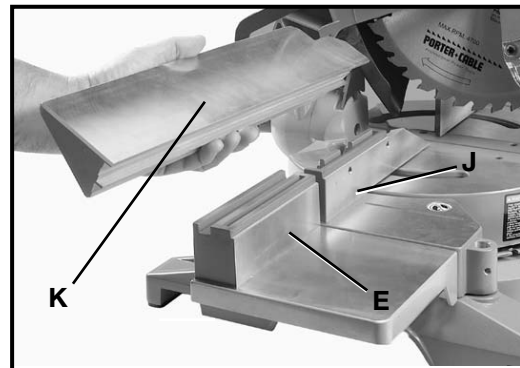

Fig. 7F

5. Use a straight edge (C) Fig. 7E, to level the fence slide support (E) with saw fence (J), and tighten the two
6. Position the fence slide (K) Fig. 7F, in position on top of saw fence (J) and fence slide support (E). Slide fence slide (K) back and forth several times to check alignment of fence slide support (E). Make any necessary final adjustments to fence slide support.

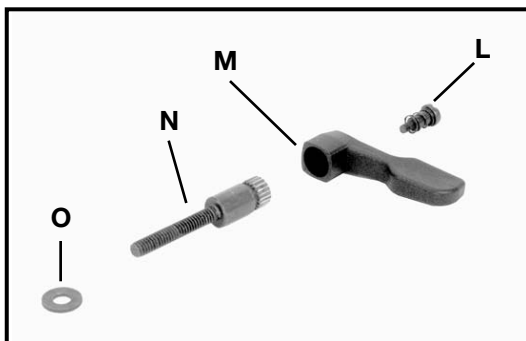

Fig. 7G

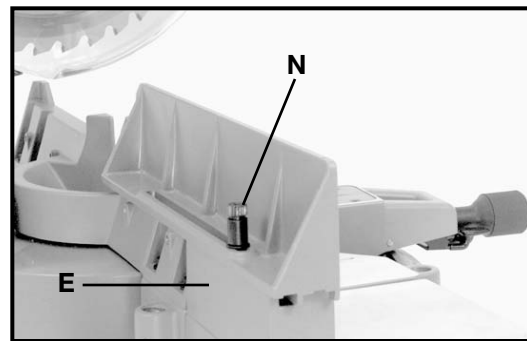

Fig. 7H

7. Remove screw and spring (L) Fig. 7G, and lock handle (M) from locking stud (N).
8. Place 1/4" flat washer (O) Fig. 7G, onto locking stud (N) and insert locking stud (N) Fig. 7H, through slot in fence slide. Thread locking stud into threaded hole in fence slide support (E).

9. Position lock handle (M) Fig. 11, on stud and replace screw and spring (L) that were removed in **STEP 7**. **NOTE:** Lock handle (M) is spring-loaded and can be repositioned by lifting up on handle.

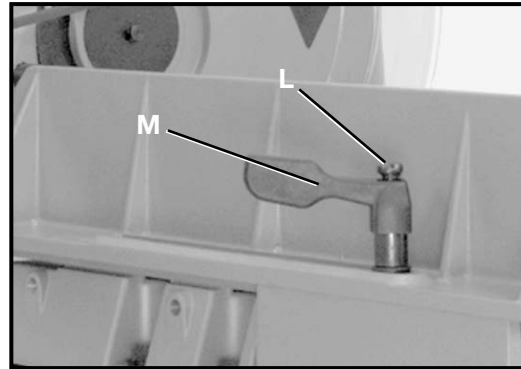

Fig. 7J

### ATTACHING DUST BAG

Depress spring clips (A) Fig. 8, of dust bag (B) and clip dust bag (B) onto end of dust chute.

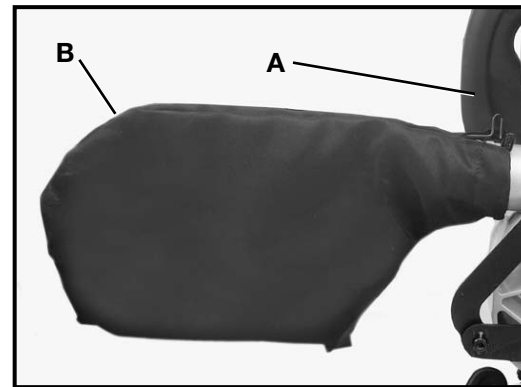

Fig. 8

### FASTENING MACHINE TO SUPPORTING SURFACE

Before operating your compound miter saw, firmly mount it to a workbench or other supporting surface. Four holes, (A) Fig. 9, are provided for fastening the saw to a supporting surface.

When frequently moving the saw from place to place, mount the saw to a 3/4" piece of plywood. The saw can then be easily moved from place to place and the plywood can be clamped to the supporting surface using "C" clamps.

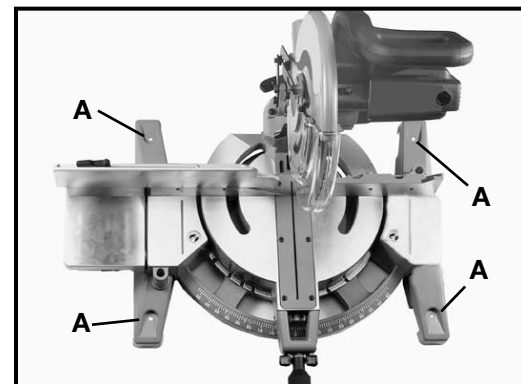

Fig. 9

### STARTING AND STOPPING MACHINE

To start the machine, depress switch trigger (A) Fig. 10. To stop the machine, release the switch trigger.

This saw is equipped with an automatic electric blade brake. As soon as the switch trigger (A) Fig. 10, is released, the electric brake is activated and stops the blade in seconds.

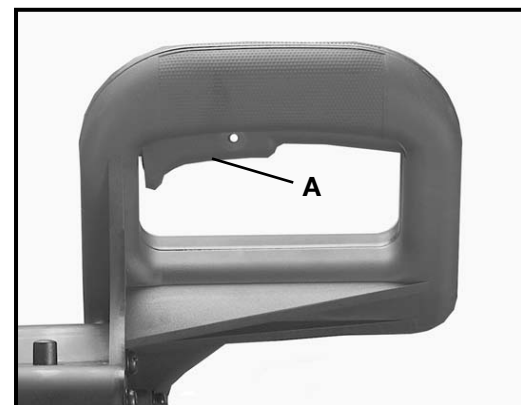

Fig. 10



**WARNING: A TURNING SAW BLADE CAN BE DANGEROUS. AFTER COMPLETING CUT, RELEASE SWITCH TRIGGER (A) FIG. 10, TO ACTIVATE BLADE BRAKE. KEEP CUTTINGHEAD DOWN UNTIL BLADE HAS COME TO A COMPLETE STOP.**

**WARNING: THE TORQUE DEVELOPED DURING BRAKING MAY LOOSEN THE ARBOR SCREW. THE ARBOR SCREW SHOULD BE CHECKED PERIODICALLY AND TIGHTENED IF NECESSARY.**

## LOCKING SWITCH IN THE “OFF” POSITION

**IMPORTANT:** When the miter saw is not in use, the switch should be locked in the OFF position using a padlock (B) Fig. 11, with a 3/16" diameter shackle to prevent unauthorized use of the saw.

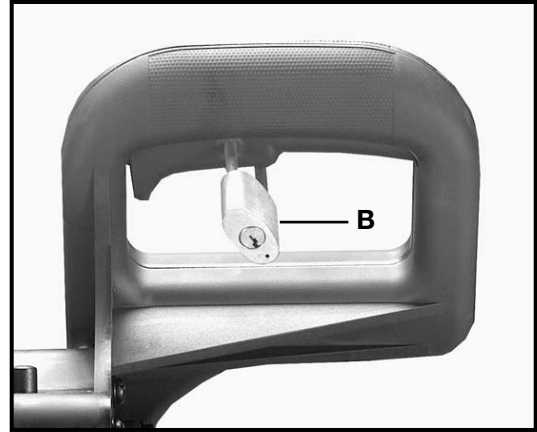

Fig. 11

## ROTATING TABLE FOR MITER CUTTING

1. The compound miter saw will cut any angle from a straight 0 degree cut to 47 degrees right and left. Rotate locking knob (A) Fig. 12, depress lock lever (B), and rotate table to desired position.

2. The compound miter saw is equipped with positive stops at the 0 degree cut-off position and at the 15, 22.5, 31.62, and 45 degree left and right positions.

3. The center line, (C) Fig. 13, on the cursor indicates the actual angle of cut. Each scale line (B) represents one degree. In effect, when the center line (C) is moved from one line to the next on the scale, the angle of the cut is changed by one degree.

4. The pointer is provided with two additional lines (D) and (E), Fig. 15. This allows movement of the control arm exactly 1/2 degree. For example, assume the center line (C) is pointing to the 10 degree mark on the scale, as indicated, and the angle of cut is 1/2 degree to the right. Move the control arm until the right line (E) lines up with the next line on the scale. The angle of cut will then be changed 1/2 degree to the right. If you change the angle of cut 1/2 degree to the left, use the left line (D) in the same manner.

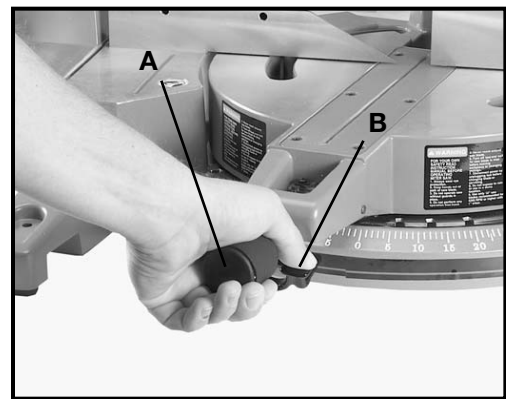

Fig. 12

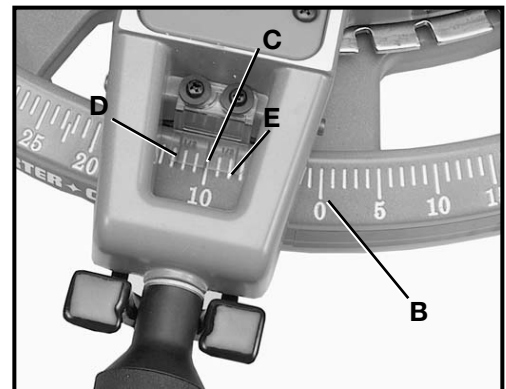

Fig. 13

## ADJUSTING SLIDING FIT BETWEEN MOVABLE TABLE AND BASE

**CAUTION: DISCONNECT THE MACHINE FROM THE POWER SOURCE.**

To adjust the sliding fit between the movable table and the base, turn nut (A) Fig. 14, clockwise to increase the sliding fit (opposite to decrease the fit). This adjustment should not be so tight that it restricts the rotating movement of the table, or so loose that it affects the accuracy of the saw.

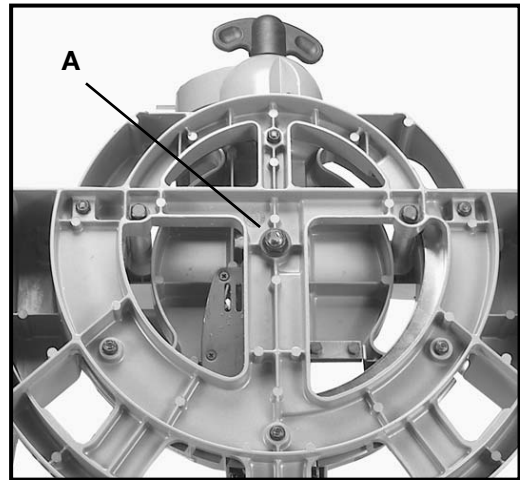

Fig. 14

### ADJUSTING FENCE 90 DEGREES TO BLADE

**IMPORTANT: BEFORE MAKING THIS ADJUSTMENT, SET THE BLADE AT 0 DEGREES TO THE TABLE. SEE SECTION “ADJUSTING 0 AND 45 DEGREE BEVEL POSITIVE STOPS.”**

1. **CAUTION: DISCONNECT THE MACHINE FROM THE POWER SOURCE.**
2. Rotate the movable table so that the blade is 90 degrees to the fence and the positive stop is set for 0 degrees.

3. Place one end of a framing square (A) against the front of the fence (B) and the other end against the blade (C), with the blade locked in the down position. The fence should be 90 degrees to the blade.

4. If an adjustment is necessary, the fence, (B) Fig. 15, can be adjusted by loosening four screws, two of which are shown at (D), that attach the fence to the base. Use the wrench supplied. Adjust the fence (B), and tighten the four screws (D).

5. When the fence is 90 degrees to the blade, adjust the cursor (F) Fig. 16, so the pointer is aligned with the 0 degree mark on the scale by loosening two screws, (G), adjusting cursor (F) and tightening screws (G).

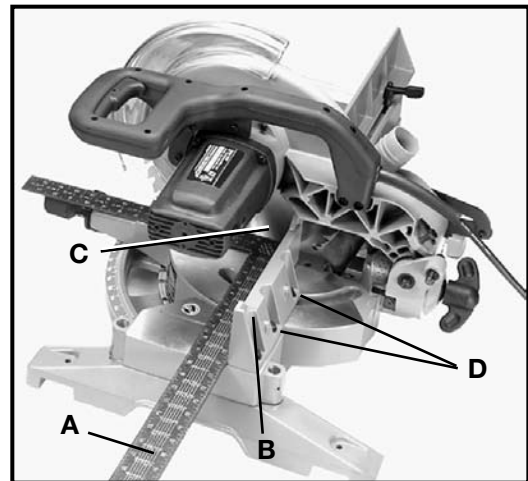

Fig. 15

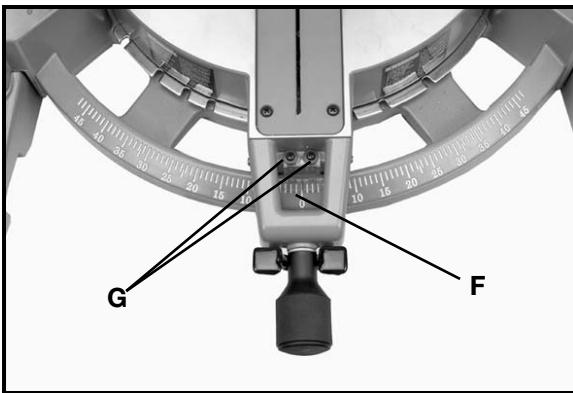

Fig. 16

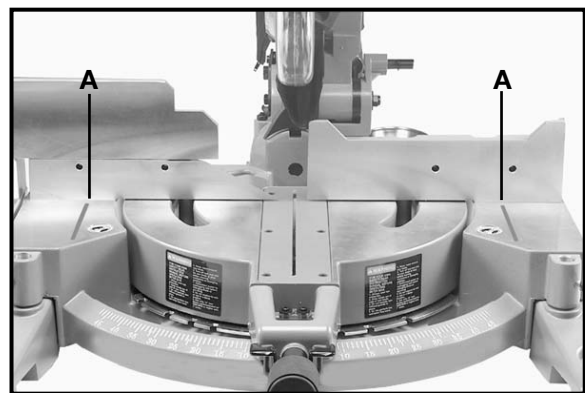

Fig. 17

### TABLE HAZARD AREA

**WARNING: THE AREA INSIDE THE TWO RED LINES (A) FIG. 17 ON THE TABLE IS DESIGNATED AS A HAZARD ZONE. NEVER PLACE YOUR HANDS INSIDE THIS AREA WHILE THE TOOL IS BEING OPERATED.**

## TILTING CUTTINGHEAD FOR BEVEL CUTTING

**CAUTION: DISCONNECT THE MACHINE FROM THE POWER SOURCE.**

**IMPORTANT: MOVE THE SLIDING FENCE TO THE LEFT TO PROVIDE CLEARANCE FOR THE BLADE AND GUARD. THE DEGREE OF TILT DETERMINES HOW FAR TO MOVE THE SLIDING FENCE. REFER TO THE SECTION “ADJUSTING SLIDING FENCE.”**

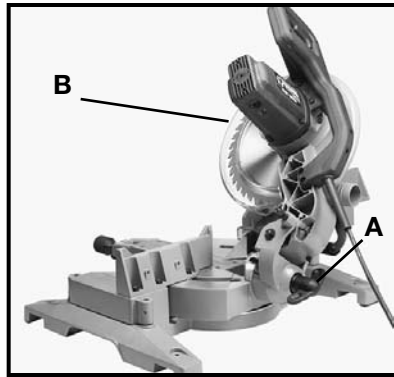

Fig. 18

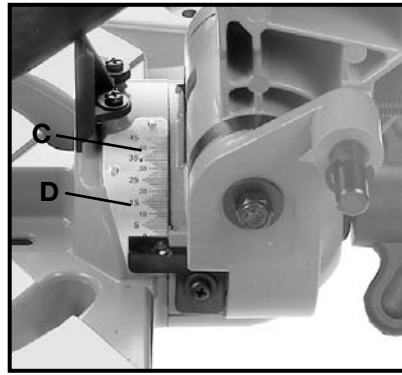

Fig. 19

1. The cuttinghead of your compound miter saw can be tilted to cut any bevel angle from a 90 degree straight cut-off to a 45 degree left bevel angle by loosening bevel lock handle (A) Fig. 18, tilting cuttinghead (B) to the desired angle, and tightening lock handle (A).
2. Positive stops are provided to rapidly position the saw blade at 90 and 45 degrees to the table. Refer to the section of this manual titled “**Adjusting 90 and 45 degree bevel positive stops.**” The bevel angle of the cutting arm is determined by the position of the pointer (C) Fig. 19, on scale (D).
3. In addition, a marked indicator is provided on the bevel scale (33.9 degrees) for cutting crown moulding. Refer to the “**CUTTING CROWN MOULDING**” section of this manual.

## ADJUSTING SLIDING FENCE

The high sliding fence Fig. 20, provides support for extra large workpieces used with your saw and should always be set as close as possible to the saw blade. When miter cutting (blade set 90 degrees to the table and at an angle to the right or left), the fence should be set all the way toward the blade, (Fig. 20). When bevel cutting, however (blade tilted at an angle to the table), the fence (A) Fig. 21, should be moved away from the blade to allow for proper clearance for the saw blade and guard, (Fig. 21). To accomplish this movement, loosen the lock handle (B), and slide the fence (A) to the desired location. Tighten the lock handle (B).

**NOTE:** Lock handle (B) is spring-loaded and can be repositioned. Pull up on handle to reposition it on the serrated nut located underneath handle.

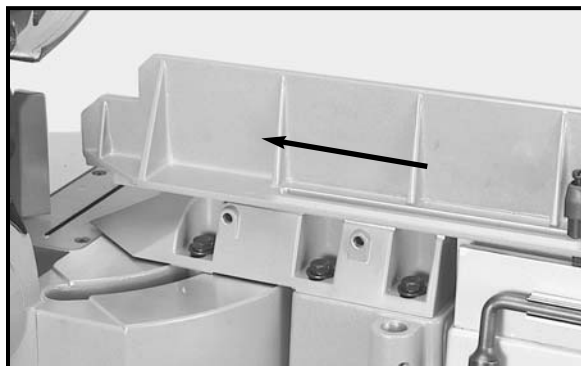

Fig. 20

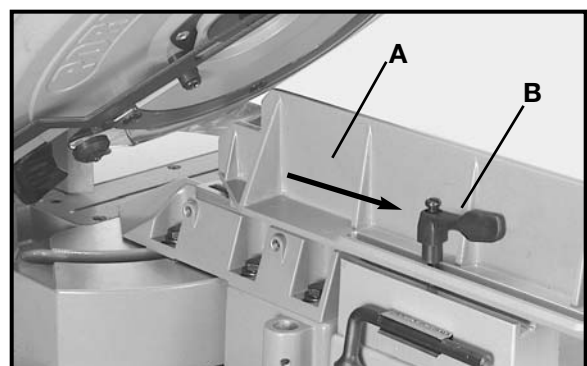

Fig. 21

## ADJUSTING CHIP DEFLECTOR

1. **DISCONNECT THE SAW FROM THE POWER SOURCE.**
2. A chip deflector (A) Fig. 22, is supplied to help prevent scrap or cut-off pieces from entering the upper blade guard. The chip deflector (A) should be adjusted so that it is almost touching the side of the blade by loosening screw (B), adjusting chip deflector (A) and tightening screw (B).

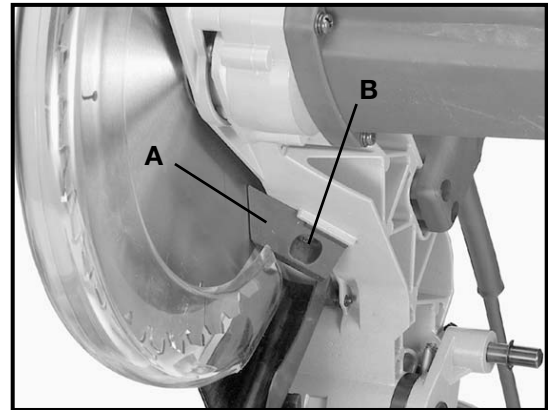

Fig. 22

## ADJUSTING 0 AND 45 DEGREE BEVEL POSITIVE STOPS

1. **DISCONNECT THE SAW FROM THE POWER SOURCE.**
2. Adjust saw so that both bevel and miter pointers are set at 0 degrees. Tighten bevel lock handle and lock cuttinghead in down position.
3. Place one end of a square (A) Fig. 23 on the table and the other end against the blade. The blade should be set at 90 degrees to the table.
4. If an adjustment is necessary, loosen bevel lock handle (H) Fig. 24. Loosen locknut (B) and turn adjusting screw (C), with wrenches provided, until blade is 90 degrees to the table. Tighten locknut (B) and bevel lock handle (H).
5. When the blade is 90 degrees to the table, adjust the pointer to line up with the 0 degree mark on the bevel scale.
6. Loosen bevel lock handle (H) Fig. 24, and move cuttinghead all the way to the left bevel position and tighten bevel lock handle.
7. Use a square (A) Fig. 25, to see if the blade is at 45 degrees to the table.
8. If an adjustment is necessary, loosen the bevel lock handle. Loosen the locknut (E) Fig. 26, and turn the adjusting screw (F), with wrenches provided, until the blade is 45 degrees to the table. Tighten locknut (E) and bevel lock handle.
9. These positive stops enable the operator to rapidly position the blade at the most common bevel angles to the table, 90 and 45 degrees.

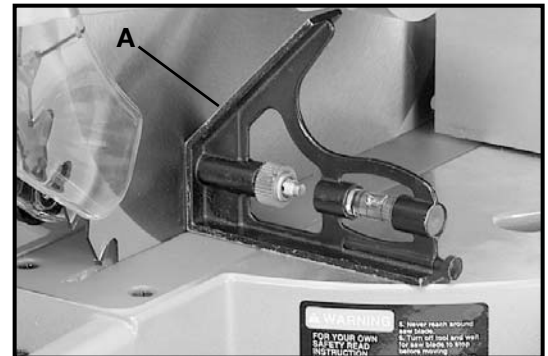

Fig. 23

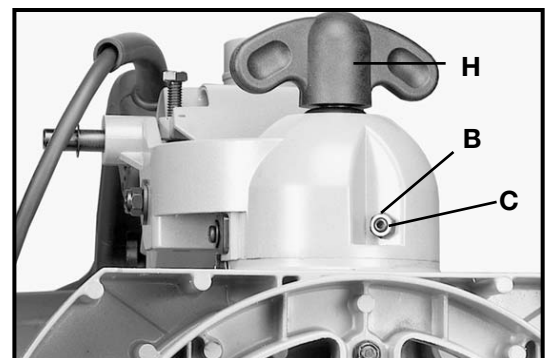

Fig. 24



Fig. 25

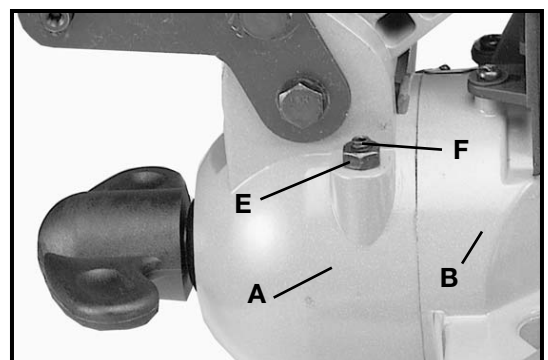

Fig. 26

## ADJUSTING SLIDING FIT BETWEEN TRUNNION AND BEVEL BRACKET

After a long period of time, it may become necessary to adjust the sliding fit between the trunnion (A) Fig. 27, and the bevel bracket (B) by tightening the adjusting nut (C), Fig. 27, located underneath the bevel lock (A), Fig. 27, and collar (B) Fig. 27.

Correct adjustment provides for a good snug sliding fit between these two parts. This adjustment should not be so tight that it restricts the tilting movement of the trunnion (A) when bevel cutting, or so loose that it affects the accuracy of the saw cut.

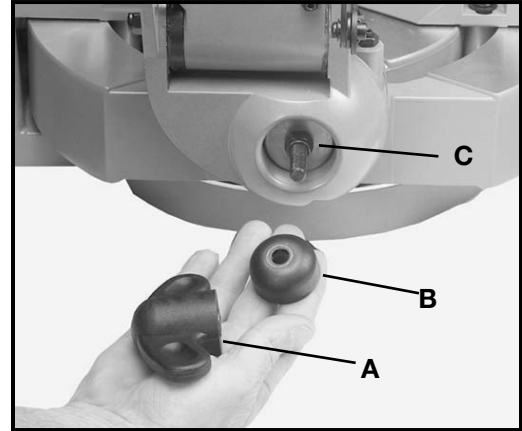

Fig. 27

## ADJUSTING THE TENSION OF CUTTINGHEAD RETURN SPRING

The tension of the cuttinghead return spring has been adjusted at the factory in order that the cuttinghead returns to the up position after a cut has been made. To re-adjust the spring tension, turn adjusting screw (A) Fig. 28, clockwise to increase or counterclockwise to decrease the spring tension.

## ADJUSTING SLIDING FIT BETWEEN CUTTINGHEAD ARM AND TRUNNION

After a long period of time, an adjustment of the sliding fit between the cuttinghead arm (B) Fig. 28, and the trunnion (C) may be necessary. To adjust, tighten nut (D). Correct adjustment is a good snug sliding fit between these two parts. This adjustment should not be so tight that it restricts the sliding movement of the cuttinghead arm (B) or so loose that it affects the accuracy of the saw cut.

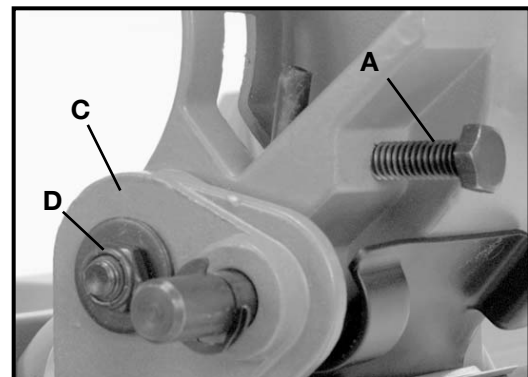

Fig. 28

## ADJUSTING DOWNWARD TRAVEL OF SAW BLADE

1. **DISCONNECT THE SAW FROM THE POWER SOURCE.**
2. The downward travel of the saw blade can be limited to prevent the saw blade from contacting any metal surfaces of the machine. This adjustment is made by loosening locknut (A) Fig. 29, and turning adjusting screw (B) in or out until other end of screw (B) contacts stop (C) at the full downward travel of the saw blade.
3. When making this adjustment, **MAKE SURE THE MACHINE IS DISCONNECTED FROM THE POWER SOURCE** and lower the blade as far as possible. Rotate the blade by hand to make certain the teeth do not contact any metal surfaces and adjust if necessary. After adjustment is completed, tighten locknut (A) Fig. 29.

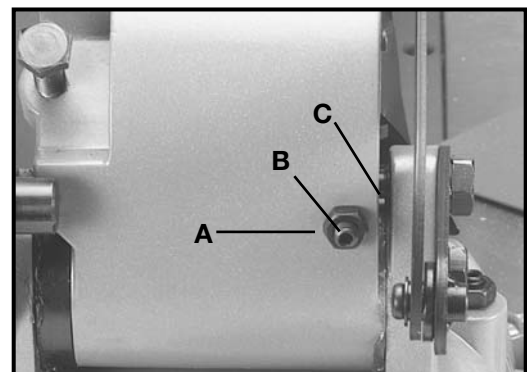

Fig. 29

## ADJUSTING BLADE GUARD

After an extended period of time the movable blade guard (A) Fig. 30, might become sloppy and move erratically when the cuttinghead is lowered. This can be easily corrected by slightly tightening nut (B) until the lower blade guard (A) moves smoothly.

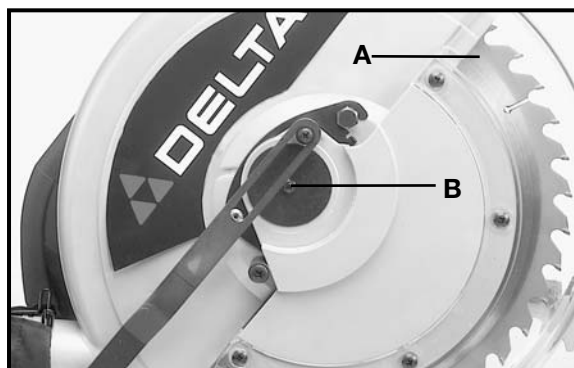

Fig. 30

## TYPICAL OPERATIONS AND HELPFUL HINTS

1. Before cutting, make certain the cutting arm and table area are at their correct settings and firmly locked in place.
2. Before cutting, determine that the workpiece is the right size for the saw.
3. Place the workpiece on the table and hold or clamp it firmly against the fence.
4. **WARNING:** If the workpiece causes your hand to be inside the table hazard area (see section “**TABLE HAZARD AREA**”), clamp the workpiece in place before making the cut.
5. For best results, cut at a slow, even cutting rate.
6. Never attempt any freehand cutting (wood that is not held firmly against the fence and table).

## AUXILIARY WOOD FENCE

When performing multiple or repetitive cut-off operations that result in small cut-off pieces (one inch or less), the saw blade can catch the cut-off pieces and project them out of the machine or into the blade guard and housing, possibly causing damage and/or injury. In order to limit the possibility of personal injury or blade guard damage, an auxiliary wood fence can be mounted to your saw as follows:

Holes are provided in the fence to attach an auxiliary fence (A) and (B) Fig. 31. This auxiliary fence is constructed of straight wood approximately 1/4” thick by 3/4” high by 16 inches long as shown at (B); and 1/2” thick by 5” high by 17” long (A) Fig. 31.

**NOTE:** The auxiliary fence (A) is used **only** with the saw blade in the 0 degree bevel position (90 degrees) to the table. The auxiliary fence must be removed for all bevel cuts (blade tilted).

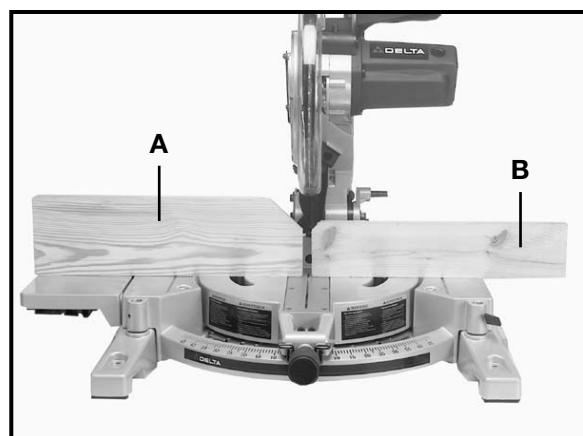

Fig. 31

## CUTTING ALUMINUM

Aluminum extrusions (aluminum screens and storm windows) can easily be cut with your miter saw. When cutting aluminum extrusions, or other sections that can be cut with a saw blade and are within the capacity of the machine, position the material so the blade is cutting through the smallest cross-section, as shown in Fig. 32. The wrong way to cut aluminum angles is illustrated in Fig. 33. Be sure to apply a stick wax (similar to Johnson's stick wax #140) to the blade before cutting any aluminum stock. This stick wax is available at most industrial mill supply houses. The stick wax provides proper lubrication and keeps chips from adhering to the blade. **NEVER APPLY LUBRICANT TO THE BLADE WHILE THE MACHINE IS RUNNING.**

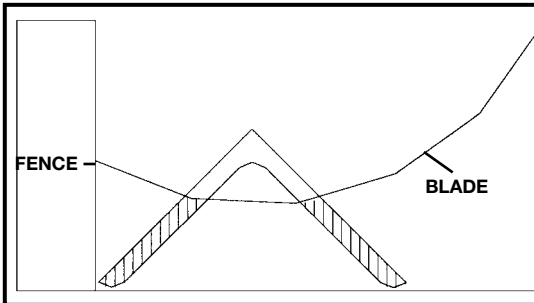

Fig. 32

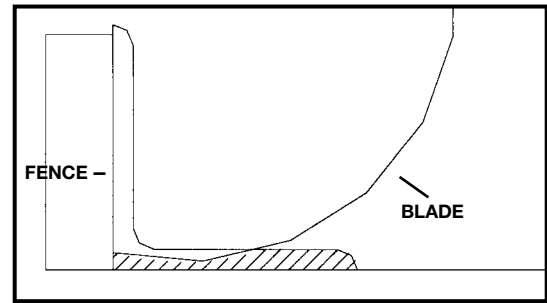

Fig. 33

## CUTTING BOWED MATERIAL

1. When cutting flat pieces, first check to see if the material is bowed. If it is, make sure the material is positioned on the table as shown in Fig. 34.
2. If the material is positioned the wrong way, as shown in Fig. 35, the workpiece will pinch the blade near the completion of the cut.

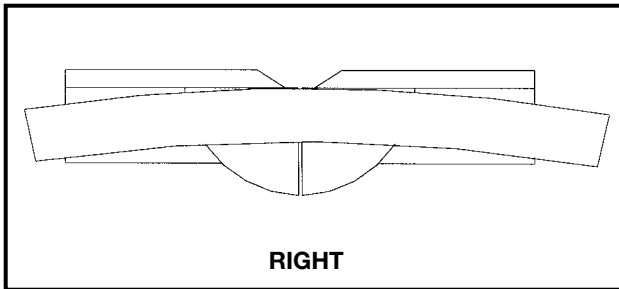

Fig. 34

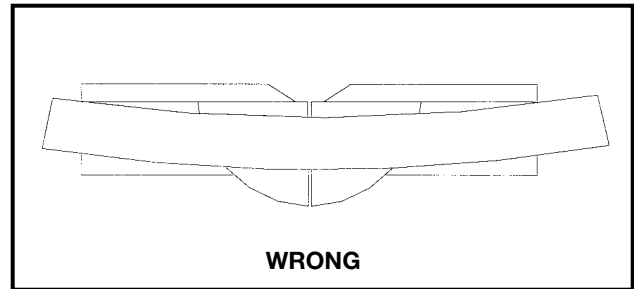

Fig. 35

## CUTTING CROWN MOULDING

One of the many features of the saw is the ease of cutting crown moulding. The following is an example of cutting both inside and outside corners on 52/38 degree wall angle crown moulding.

**NOTE:** The following procedure for inside or outside crown molding corners is the same with the exception that the bevel position will always be at 30 degrees and the miter position will be 35-1/4 degrees to the right or left.

1. Move the table to the 31-5/8th degree right miter position and lock the table in position. **NOTE:** A positive stop is provided to find this angle quickly.
2. Tilt the saw blade to the 33-7/8 degree left bevel position and tighten bevel lock handle. **NOTE:** A triangle indicator is provided on the bevel scale to find this angle quickly.
3. Place the crown moulding on the table with the **CEILING EDGE** of the moulding against the fence, and make the cut, as shown in Fig. 36.

**NOTE:** The piece of crown moulding used for the outside corner will always be on the right hand side of the blade, as shown at (A) Fig. 36. The piece of crown moulding used for the inside corner will always be on the left hand side of the blade, as shown at (B) Fig. 36.

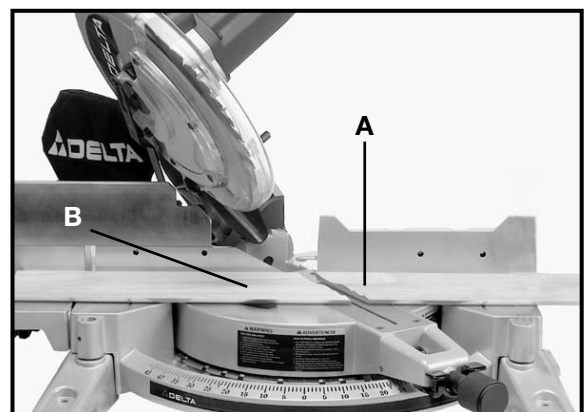

Fig. 36

4. To make the matching halves of the inside and outside corners, simply rotate the table to the 31-5/8 degree left miter position.

**NOTE:** A positive stop is provided to find this angle quickly. The saw blade is already tilted to the 33-7/8 degree bevel position from the previous cut.

5. Place the crown moulding on the table with the **WALL EDGE** of the crown moulding against the fence and make the cut. Again, the piece of crown moulding used for the outside corner will always be on the right side of the blade, as shown at (C) Fig. 37. The piece of crown moulding used for the inside corner will always be on the left side of the blade, as shown at (D) Fig. 37.

6. Fig. 38 illustrates the two outside corner pieces; (1) being the piece cut at (D) Fig. 43 and (2) being the piece cut at (C) Fig. 37.

7. Fig. 39 illustrates the two inside corner pieces; (1) being the piece cut at (B) Fig. 37, and (2) being the piece cut at (A) Fig. 37.

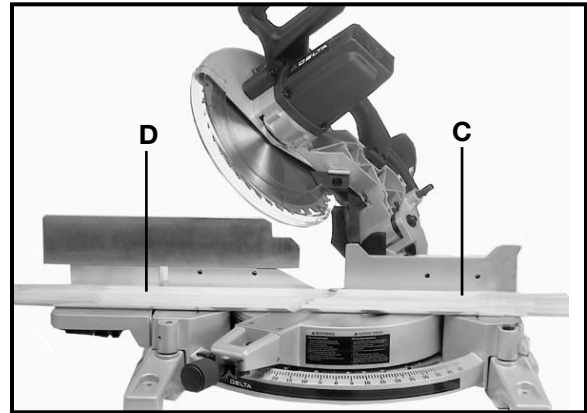

Fig. 37

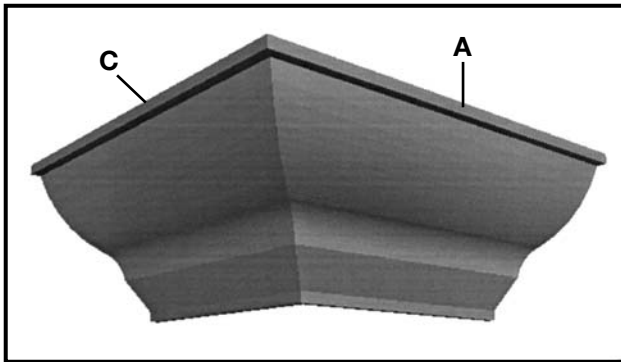

Fig. 38

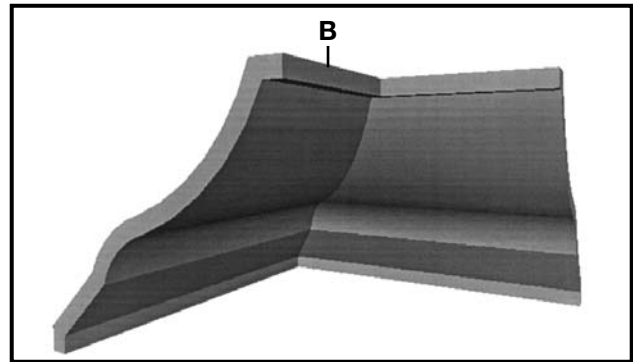

Fig. 39

## CONSTRUCTING WORK SUPPORT EXTENSIONS

One of the unique features of the miter saw is the ease of constructing work supports. Fig. 40 illustrates the miter saw mounted to two standard 2 x 4's (A). Fasten the grooves in the two mounting legs (B), to the 2 x 4's, using four screws through the four holes in the mounting legs. The length of the 2 x 4's (A) can vary, depending on preference. The distance from the top of the 2 x 4's (A) to the compound miter saw table 3 1/4". Standard 2 x 4's (C) can then be fastened to the top of the 2 x 4's (A). The top of the 2 x 4's (C) will then be the same height as the miter saw table, or minor adjustments can easily be made depending on the height of the 2 x 4's. This method will provide support for long workpieces using standard 2 x 4's instead of constructing an expensive, complicated work support.

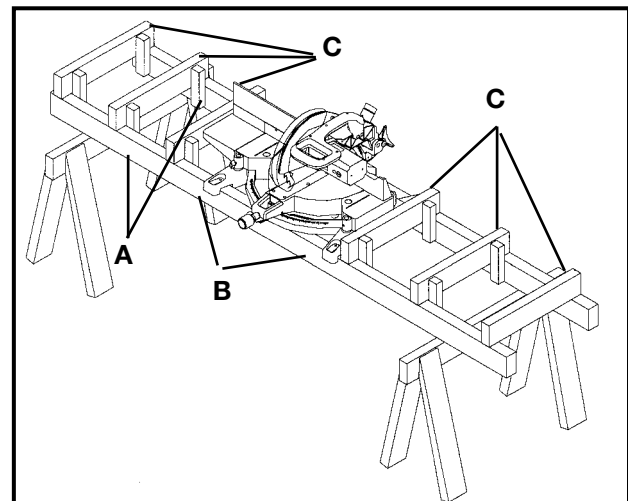

Fig. 40



# MAINTENANCE

## CHANGING THE BLADE

**WARNING: USE ONLY CROSS-CUTTING SAW BLADES. DO NOT USE BLADES WITH DEEP GULLETS AS THEY CAN DEFLECT AND CONTACT GUARD**

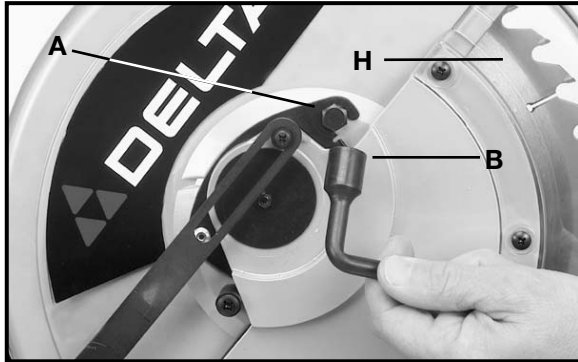

Fig. 41

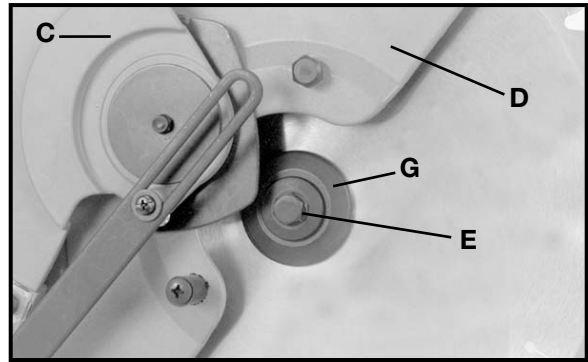

Fig. 42

1. Use only 12" diameter blades with 1" arbor holes that are rated for 4200 RPM or higher.
2. **DISCONNECT MACHINE FROM THE POWER SOURCE.**
3. Loosen screw (A) Fig. 41, with wrench (B) (provided).
4. Rotate arbor cover (C) Fig. 42, and lower guard (D) Fig. 42, to the rear, exposing arbor screw (E).
5. Remove arbor screw (E) Fig. 42, by turning screw clockwise with wrench (supplied), while at the same time, pressing in on arbor lock (F) Fig. 43, to keep the arbor from turning. Remove outside blade flange (G) Fig. 42, and saw blade (H) Fig. 41. **DO NOT REMOVE INSIDE BLADE FLANGE.**
6. Attach the new saw blade **MAKING CERTAIN TEETH OF SAW BLADE ARE POINTING DOWN AT THE FRONT**, and attach outside blade flange (G) Fig. 42. Check to see that the flats on outside blade flange are engaged with flats on arbor shaft.
7. Thread arbor screw (E) Fig. 42, into saw arbor by turning screw (E) counterclockwise as far as possible by hand. Then tighten arbor screw (E) with wrench supplied while at the same time pressing in on arbor lock (F) Fig. 43, to keep arbor from turning.
8. Rotate arbor cover (C) Fig. 42, and lower guard (D) to the front and tighten screw (A) that was loosened in **STEP 3.**

## BRUSH INSPECTION AND REPLACEMENT

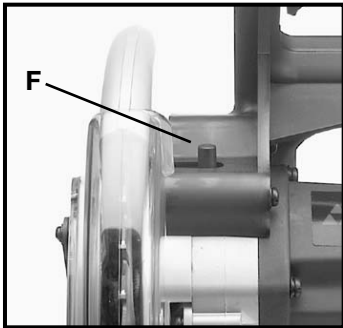

Fig. 43

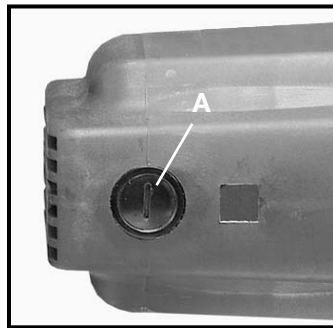

Fig. 44

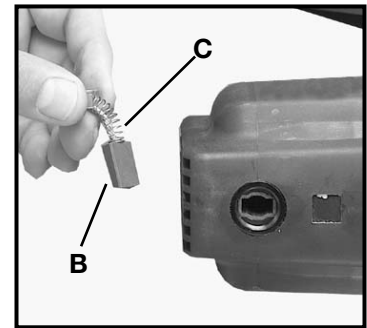

Fig. 45

**CAUTION: BEFORE INSPECTING BRUSHES, DISCONNECT THE MACHINE FROM THE POWER SOURCE.**

Brush life varies, depends on the load on the motor. Check the brushes after the first 50 hours of use of a new machine, or after a new set of brushes has been installed.

After the first check, examine them after about 10 hours of use, until replacement is necessary.

The brush holders (A) Fig. 44, are located on the motor housing opposite each other. Fig. 45, illustrates one of the brushes removed for inspection. When the carbon on either brush (B) is worn to 3/16" in length, or if either spring or shunt wire (C) is burned or damaged in any way, replace both brushes. If the brushes are found serviceable after removing, reinstall them in the same position.

## KEEP TOOL CLEAN

Periodically blow out all air passages with dry compressed air. Clean all plastic parts with a soft damp cloth. NEVER use solvents to clean plastic parts. They could possibly dissolve or otherwise damage the material.

**CAUTION: WEAR SAFETY GLASSES WHILE USING COMPRESSED AIR.**

## FAILURE TO START

Should your tool fail to start, check to make sure the prongs on the cord plug are making good contact with the outlet. Also, check for blown fuses or open circuit breakers in the line.

# ACCESSORIES

A complete line of accessories is available from your Delta Supplier, Porter-Cable • Delta Factory Service Centers, and Delta Authorized Service Stations. Please visit our Web Site [www.deltamachinery.com](http://www.deltamachinery.com) for a catalog or for the name of your nearest supplier.

 **WARNING:** Since accessories, other than those offered by Delta, have not been tested with this product, use of such accessories could be hazardous. For safest operation, use only Delta recommended accessories with this product.

35-646  
35-651  
1347295

62 TOOTH BLADE  
96 TOOTH BLADE  
WORK CLAMP



## PARTS, SERVICE OR WARRANTY ASSISTANCE

All Delta Machines and accessories are manufactured to high quality standards and are serviced by a network of Porter-Cable • Delta Factory Service Centers and Delta Authorized Service Stations. To obtain additional information regarding your Delta quality product or to obtain parts, service, warranty assistance, or the location of the nearest service outlet, please call 1-800-223-7278 (In Canada call 1-800-463-3582).



### Delta Building Trades and Home Shop Machinery Two Year Limited Warranty

Delta will repair or replace, at its expense and at its option, any Delta machine, machine part, or machine accessory which in normal use has proven to be defective in workmanship or material, provided that the customer returns the product prepaid to a Delta factory service center or authorized service station with proof of purchase of the product within two years and provides Delta with reasonable opportunity to verify the alleged defect by inspection. Delta may require that electric motors be returned prepaid to a motor manufacturer's authorized station for inspection and repair or replacement. Delta will not be responsible for any asserted defect which has resulted from normal wear, misuse, abuse or repair or alteration made or specifically authorized by anyone other than an authorized Delta Service facility or representative. Under no circumstances will Delta be liable for incidental or consequential damages resulting from defective products. This warranty is Delta's sole warranty and sets forth the customer's exclusive remedy, with respect to defective products; all other warranties, express or implied, whether of merchantability, fitness for purpose, or otherwise, are expressly disclaimed by Delta.

# NOTES

## PORTER-CABLE • DELTA SERVICE CENTERS (CENTROS DE SERVICIO DE PORTER-CABLE • DELTA)

Parts and Repair Service for Porter-Cable•Delta Power Tools are Available at These Locations  
(Obtenga Refaccion de Partes o Servicio para su Herramienta en los Siguients Centros de Porter-Cable•Delta)

### ARIZONA

Tempe 85282 (Phoenix)  
2400 West Southern Avenue  
Suite 105  
Phone: (602) 437-1200  
Fax: (602) 437-2200

### CALIFORNIA

Ontario 91761 (Los Angeles)  
3949A East Guasti Road  
Phone: (909) 390-5555  
Fax: (909) 390-5554

San Leandro 94577 (Oakland)  
3039 Teagarden Street  
Phone: (510) 357-9762  
Fax: (510) 357-7939

### FLORIDA

Davie 33314 (Miami)  
4343 South State Rd. 7 (441)  
Unit #107  
Phone: (954) 321-6635  
Fax: (954) 321-6638

Tampa 33609  
4538 W. Kennedy Boulevard  
Phone: (813) 877-9585  
Fax: (813) 289-7948

### GEORGIA

Forest Park 30297 (Atlanta)  
5442 Frontage Road,  
Suite 112  
Phone: (404) 608-0006  
Fax: (404) 608-1123

### ILLINOIS

Addison 60101 (Chicago)  
311 Laura Drive  
Phone: (630) 628-6100  
Fax: (630) 628-0023

Woodridge 60517 (Chicago)  
2033 West 75th Street  
Phone: (630) 910-9200  
Fax: (630) 910-0360

### MARYLAND

Elkridge 21075 (Baltimore)  
7397-102 Washington Blvd.  
Phone: (410) 799-9394  
Fax: (410) 799-9398

### MASSACHUSETTS

Braintree 02185 (Boston)  
719 Granite Street  
Phone: (781) 848-9810  
Fax: (781) 848-6759

Franklin 02038 (Boston)  
Franklin Industrial Park  
101E Constitution Blvd.  
Phone: (508) 520-8802  
Fax: (508) 528-8089

### MICHIGAN

Madison Heights 48071 (Detroit)  
30475 Stephenson Highway  
Phone: (248) 597-5000  
Fax: (248) 597-5004

### MINNESOTA

Minneapolis 55429  
4315 68th Avenue North  
Phone: (763) 561-9080  
Fax: (763) 561-0653

### MISSOURI

North Kansas City 64116  
1141 Swift Avenue  
P.O. Box 12393  
Phone: (816) 221-2070  
Fax: (816) 221-2897

St. Louis 63119  
7574 Watson Road  
Phone: (314) 968-8950  
Fax: (314) 968-2790

### NEW YORK

Flushing 11365-1595 (N.Y.C.)  
175-25 Horace Harding Expwy.  
Phone: (718) 225-2040  
Fax: (718) 423-9619

### NORTH CAROLINA

Charlotte 28270  
9129 Monroe Road, Suite 115  
Phone: (704) 841-1176  
Fax: (704) 708-4625

### OHIO

Columbus 43214  
4560 Indianola Avenue  
Phone: (614) 263-0929  
Fax: (614) 263-1238

Cleveland 44125  
8001 Sweet Valley Drive  
Unit #19  
Phone: (216) 447-9030  
Fax: (216) 447-3097

### OREGON

Portland 97230  
4916 NE 122 nd Ave.  
Phone: (503) 252-0107  
Fax: (503) 252-2123

### PENNSYLVANIA

Willow Grove 19090  
520 North York Road  
Phone: (215) 658-1430  
Fax: (215) 658-1433

### TEXAS

Carrollton 75006 (Dallas)  
1300 Interstate 35 N, Suite 112  
Phone: (972) 446-2996  
Fax: (972) 446-8157

Houston 77055  
West 10 Business Center  
1008 Wirt Road, Suite 120  
Phone: (713) 682-0334  
Fax: (713) 682-4867

### WASHINGTON

Renton 98055 (Seattle)  
268 Southwest 43rd Street  
Phone: (425) 251-6680  
Fax: (425) 251-9337

Authorized Service Stations are located in many large cities. Telephone **800-487-8665** or **731-541-6042** for assistance locating one. Parts and accessories for Porter-Cable•Delta products should be obtained by contacting any Porter-Cable•Delta Distributor, Authorized Service Center, or Porter-Cable•Delta Factory Service Center. If you do not have access to any of these, call **888-848-5175** and you will be directed to the nearest Porter-Cable•Delta Factory Service Center. Las Estaciones de Servicio Autorizadas están ubicadas en muchas grandes ciudades. Llame al **800-487-8665** ó al **731-541-6042** para obtener asistencia a fin de localizar una. Las piezas y los accesorios para los productos Porter-Cable•Delta deben obtenerse poniéndose en contacto con cualquier distribuidor Porter-Cable•Delta, Centro de Servicio Autorizado o Centro de Servicio de Fábrica Porter-Cable•Delta. Si no tiene acceso a ninguna de estas opciones, llame al **888-848-5175** y le dirigirán al Centro de Servicio de Fábrica Porter-Cable•Delta más cercano.

## CANADIAN PORTER-CABLE • DELTA SERVICE CENTERS

### ALBERTA

Bay 6, 2520-23rd St. N.E.  
Calgary, Alberta  
T2E 8L2  
Phone: (403) 735-6166  
Fax: (403) 735-6144

### BRITISH COLUMBIA

8520 Baxter Place  
Burnaby, B.C.  
V5A 4T8  
Phone: (604) 420-0102  
Fax: (604) 420-3522

### MANITOBA

1699 Dublin Avenue  
Winnipeg, Manitoba  
R3H 0H2  
Phone: (204) 633-9259  
Fax: (204) 632-1976

### ONTARIO

505 Southgate Drive  
Guelph, Ontario  
N1H 6M7  
Phone: (519) 836-2840  
Fax: (519) 767-4131

### QUÉBEC

1515 Avenue  
St-Jean Baptiste  
Québec, Québec  
G2E 5E2  
Phone: (418) 877-7112  
Fax: (418) 877-7123

1447, Begin  
St-Laurent, (Montréal), Québec  
H4R 1V8  
Phone: (514) 336-8772  
Fax: (514) 336-3505

The following are trademarks of PORTER-CABLE•DELTA (Las siguientes son marcas registradas de PORTER-CABLE S.A.): BAMMER®, INNOVATION THAT WORKS®, JETSTREAM®, LASERLOC®, OMNIGIG®, POCKET CUTTER®, PORTA-BAND®, PORTA-PLANE®, PORTER-CABLE®, QUICKSAND®, SANDTRAP®, SAW BOSS®, SPEED-BLOC®, SPEEDMATIC®, SPEEDTRONIC®, STAIR-EASE®, THE PROFESSIONAL EDGE®, THE PROFESSIONAL SELECT®, TIGER CUB®, TIGER SAW®, TORQBUSTER®, WHISPER SERIES®, DURATRONIC™, FLEX™, FRAME SAW™, MICRO-SET™, MORTEN™, NETWORK™, RIPTIDE™, TRU-MATCH™, WOODWORKER'S CHOICE™.

Trademarks noted with ® are registered in the United States Patent and Trademark Office and may also be registered in other countries. Las Marcas Registradas con el signo de ® son registradas por la Oficina de Registros y Patentes de los Estados Unidos y también pueden estar registradas en otros países.