

**DF8A Series  
Fixed Indoor Dome**

**Installation/  
Operation Manual**

**C1448M-C (8/02)**

## IMPORTANT SAFEGUARDS AND WARNINGS

Observe the following WARNINGS before installing and using this product.

1. Read these instructions.
2. Keep these instructions.
3. Heed all warnings.
4. Follow all instructions.
5. Do not use this apparatus near water.
6. Clean only with dry cloth.
7. Do not block any ventilation openings. Install in accordance with the manufacturer's instructions.
8. Do not install near any heat sources, such as radiators, heat registers, stoves, or other apparatus (including amplifiers) that produce heat.
9. Only use attachments/accessories specified by the manufacturer.
10. Use only with the cart, stand, tripod, bracket, or table specified by the manufacturer or sold with the apparatus. When a cart is used, use caution when moving the cart/apparatus combination to avoid injury from tip-over.
11. Refer all servicing to qualified service personnel. Servicing is required when the apparatus has been damaged in any way, such as power-supply cord or plug is damaged, liquid has been spilled or objects have fallen into the apparatus, the apparatus has been exposed to rain or moisture, the apparatus does not operate normally, or the apparatus has been dropped.
12. Apparatus shall not be exposed to dripping or splashing, and no objects filled with liquids, such as vases, shall be placed on the apparatus.
13. **Warning:** To reduce the risk of fire or electric shock, do not expose this apparatus to rain or moisture.
14. To reduce the risk of shock, do not perform any servicing other than that contained in the operating instructions unless you are qualified to do so.
15. The installation method and materials should be capable of supporting four times the weight of the unit and equipment.
16. Only use replacement parts recommended by Pelco.

The product and/or manual may bear the following marks:



This symbol indicates that dangerous voltage constituting a risk of electric shock is present within this unit.



This symbol indicates that there are important operating and maintenance instructions in the literature accompanying this unit.



Please thoroughly familiarize yourself with the information in this manual prior to installation and operation.

## DESCRIPTION

The DF8A Series Fixed Dome is for indoor use in hard ceiling or standard 2 x 2 ft (6 x 61 cm) suspended ceiling installations. Products in the DF8A Series have an aluminum back box and a plastic, hemispherical viewing dome. The back box includes an adjustable camera mount.

## MODELS

DF8A	Viewing dome is smoked bronze, 1 f-stop of light loss
DF8A-0	Viewing dome is opaque black with a smoked viewing slot for the camera lens, 1/2 f-stop of light loss
DF8A-1	Same as the DF8A except the viewing dome is opaque black with a clear viewing slot
DF8A-2	Same as the DF8A except the viewing dome is chrome in color, 2 f-stops of light loss
DF8A-3	Same as the DF8A except the viewing dome is gold in color, 2 f-stops of light loss
DF8A-10	Same as the DF8A except the viewing dome is opaque white with a clear viewing slot for the camera lens

## INSTALLATION

The following parts are supplied:

- 1 Back box, trim ring, and dome
- 1 Compass tool
- 1 Safety chain bracket
- 1 Conduit fitting
- 1 Lock nut
- 1 1/4-20 x 1/2-inch bolt
- 1 1/4-inch flat washer
- 1 1/4-inch lock washer

## IN-CEILING MODELS

### HARD CEILING INSTALLATION

#### ① PREPARE CEILING

Locate the center point of the mounting location. Drill a hole in the ceiling using a 3/32-inch drill. Insert the compass tool into the hole. Use a pencil and the compass tool to draw a circle on the ceiling. Carefully cut out the circle.

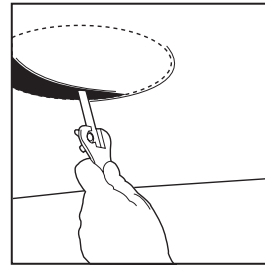
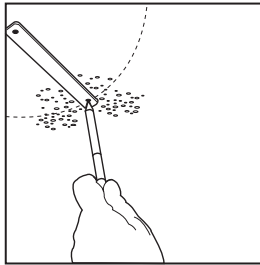
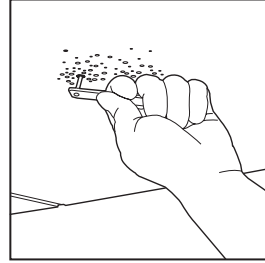
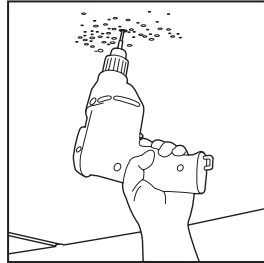

#### ② INSTALL THE BACK BOX

Attach the conduit fitting, lock nut, and safety chain bracket. Install a safety chain/cable (not supplied) that will support up to 16 pounds (7.3 kg). Install one end of the safety chain/cable to the safety chain bracket and the other end to a support structure in the ceiling.

Prepare the wiring for camera and lens power; refer to Tables A and B for wiring distances. Pull wiring into the back box through the conduit fitting.

Compress the spring clips on the back box and push it through the hole until the clips spring back. Tighten the screws until you hear a clicking noise.

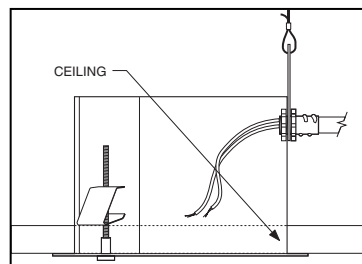
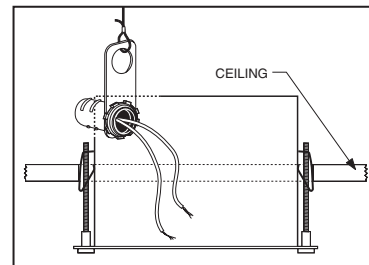
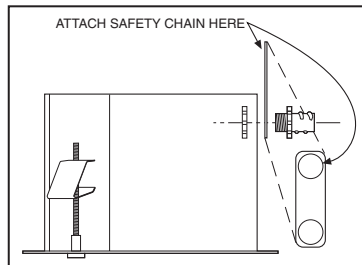

**NOTE:** The ceiling tile cannot be thinner than 0.50-inch (1.27 cm) or thicker than 1.75 inches (4.45 cm).

## SUSPENDED CEILING INSTALLATION

### 1 PREPARE CEILING TILE

Remove the ceiling tile from the ceiling. Insert the compass tool (supplied) into the center of the tile. (If necessary, use a 3/32-inch bit to drill a hole.) Draw a circle on the tile using the compass tool and a pencil. Carefully cut out the circle.

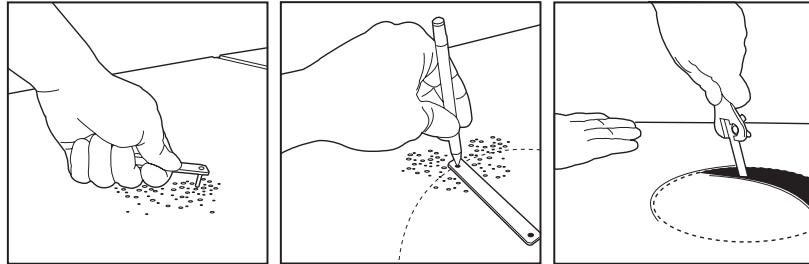

### 2 INSTALL THE BACK BOX

Attach the conduit fitting, lock nut, and safety chain bracket. Attach to the bracket one end of a safety chain/cable (not supplied) that will support up to 16 pounds (7.3 kg). Do not attach the other end yet.

Compress the spring clips on the back box and push it through the hole until the clips spring back. Tighten the screws until you hear a clicking noise. Reinstall the ceiling tile.

Remove adjacent ceiling tile. Prepare the wiring for camera and lens power; refer to Tables A and B for wiring distances. Pull wiring into the back box through the conduit fitting. Attach the safety chain to a support structure. Replace the adjacent ceiling tile.

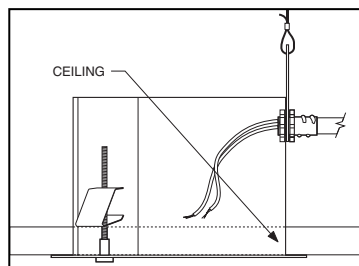
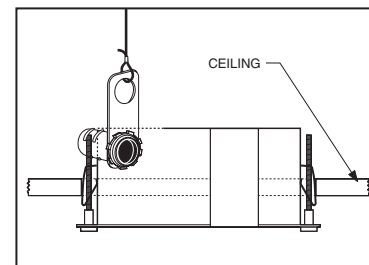
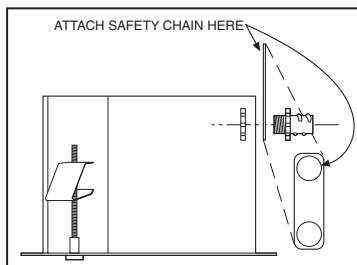

**Table A. Video Coaxial Cable Requirements**

Cable Type*	Maximum Distance
RG59/U	750 ft (229 m)
RG6/U	1,000 ft (305 m)
RG11/U	1,500 ft (457 m)

\* Minimum cable requirements:  
 75 ohms impedance  
 All-copper center conductor  
 All-copper braided shield with 95% braid coverage

**Table B. 24 VAC Wiring Distances**

The following are the recommended maximum distances for 24 VAC applications and are calculated with a 10-percent voltage drop. (Ten percent is generally the maximum allowable voltage drop for AC-powered devices.)

Total VA consumed	Wire Gauge					
	20	18	16	14	12	10
10	283 (86)	451 (137)	716 (218)	1142 (348)	1811 (551)	2880 (877)
20	141 (42)	225 (68)	358 (109)	571 (174)	905 (275)	1440 (438)
30	94 (28)	150 (45)	238 (72)	380 (115)	603 (183)	960 (292)
40	70 (21)	112 (34)	179 (54)	285 (86)	452 (137)	720 (219)
50	56 (17)	90 (27)	143 (43)	228 (69)	362 (110)	576 (175)
60	47 (14)	75 (22)	119 (36)	190 (57)	301 (91)	480 (146)
70	40 (12)	64 (19)	102 (31)	163 (49)	258 (78)	411 (125)
80	35 (10)	56 (17)	89 (27)	142 (43)	226 (68)	360 (109)

Maximum distance from transformer to load

**EXAMPLE:** An enclosure that requires 80 vA and is installed 35 feet (10 m) from the transformer would require a minimum wire gauge of 20 Awg.

**NOTE:** Distances are calculated in feet; values in parentheses are meters.

## CAMERA AND LENS INSTALLATION

To install the camera and lens:

- 1 Extend the lens to the maximum length before installing in the back box.
- 2 Attach the camera to the tilt table with the 1/4-20 screw and washers (supplied).
- 3 To ensure that the lens will not hit the lower dome:
  - Place the lower dome over the back box with the camera and lens installed (do not attach dome).
  - If the lens touches the lower dome, adjust the tilt table assembly.
- 4 Refer to the manual supplied with the camera and lens for the following information:
  - How to connect power and video wiring
  - How to make camera and lens adjustments

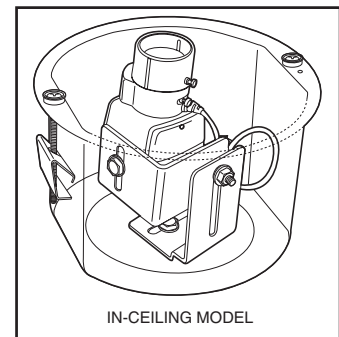

## DOMESTALLATION

1. Snap the clip, on the end of the trim ring leash, into the hole on the lip of the back box.
2. Install the dome by pushing the two ball studs on the trim ring into the retaining clips on the back box.
3. If you have a dome with black or white opaque finish, turn the dome so that the viewing slot is in front of the lens.

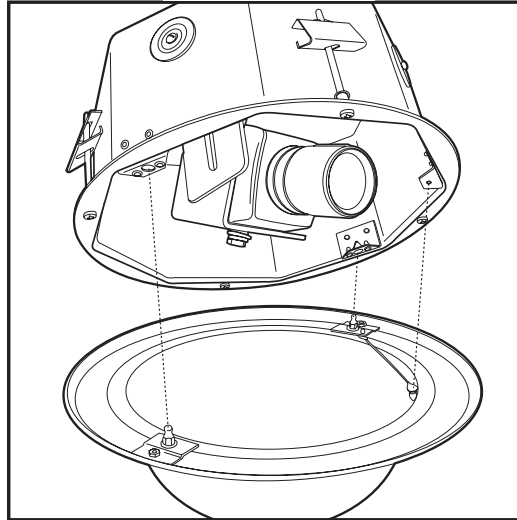

## MAINTENANCE

Clean the acrylic dome as needed. Be careful not to scratch the surfaces of the dome.

**Exterior Surface** - Clean the dome's exterior surface with a nonabrasive cleaning cloth and agent that is safe for acrylic plastic. Either liquid or spray cleaner/wax suitable for fine furniture is acceptable.

**Interior Surface (Except Chrome or Gold)** - Clean the same as the exterior surface.

**Interior Surface (Chrome or Gold)** - The inside surface of a chrome or gold dome is easily scratched. Use the following precautions to maintain the dome's surface.

- a. Always handle the dome from the outside of its circular flange.
- b. Never touch the coated inside surface. The acid in your fingerprints will eventually etch the coating if the fingerprints are not carefully removed according to the recommended cleaning procedure in item e.
- c. If dust or other contaminants accumulate on the dome's interior, remove the debris with compressed air. Compressed air cans are available from photographic equipment or electronic supply dealers.
- d. If heavy residue accumulates and cannot be removed with air pressure, rinse with water and immediately dry with air pressure so that water spots will not remain. Avoid wiping the coated surface with direct hand pressure - it will easily abrade unless extreme care is taken. Once scratched, the dome cannot be repaired.
- e. If internal wiping is necessary, avoid hand rubbing. Instead, make a wick as follows: Use a very soft paper towel. Roll a section into a tightly wound tube. Tear the tube in half, and wet the fuzzy end of the wick with a solution of isopropyl alcohol diluted with water. Hold the dome with its opening facing downward and wipe the interior of the dome with the wet end of the wick. Use a circular motion, starting from the outside and spiraling into the center. Use a new wick for each two passes over the dome.

## SERVICE MANUAL

If you need to service your unit, obtain a service manual in one of the following ways:

- Go to Pelco's web site at <ftp://www.pelco.com> and find service manual C1448SM.
- Call Pelco's DataFAX service at 1-800-289-9108 or 1-559-292-04335 and request document 214488.
- Contact Pelco's Literature Department and request service manual C1448SM.

### PRODUCT WARRANTY AND RETURN INFORMATION

#### WARRANTY

Pelco will repair or replace, without charge, any merchandise proved defective in material or workmanship for a period of one year after the date of shipment.

Exceptions to this warranty are as noted below:

- Five years on FT/FR8000 Series fiber optic products.
- Three years on Genex® Series products (multiplexers, server, and keyboard).
- Three years on Camclosure® and fixed camera models, except the CC3701H-2, CC3701H-2X, CC3751H-2, CC3651H-2X, MC3651H-2, and MC3651H-2X camera models, which have a five-year warranty.
- Two years on standard motorized or fixed focal length lenses.
- Two years on Legacy®, CM6700/CM6800/CM9700 Series matrix, and DF5/DF8 Series fixed dome products.
- Two years on Spectra®, Esprit®, ExSite™, and PS20 scanners, including when used in continuous motion applications.
- Two years on Esprit® and WW5700 Series window wiper (excluding wiper blades).
- Eighteen months on DX Series digital video recorders, NVR300 Series network video recorders, and Endura™ Series distributed network-based video products.
- One year (except video heads) on video cassette recorders (VCRs). Video heads will be covered for a period of six months.
- Six months on all pan and tilts, scanners or preset lenses used in continuous motion applications (that is, preset scan, tour and auto scan modes).

Pelco will warrant all replacement parts and repairs for 90 days from the date of Pelco shipment. All goods requiring warranty repair shall be sent freight prepaid to Pelco, Clovis, California. Repairs made necessary by reason of misuse, alteration, normal wear, or accident are not covered under this warranty.

Pelco assumes no risk and shall be subject to no liability for damages or loss resulting from the specific use or application made of the Products. Pelco's liability for any claim, whether based on breach of contract, negligence, infringement of any rights of any party or product liability, relating to the Products shall not exceed the price paid by the Dealer to Pelco for such Products. In no event will Pelco be liable for any special, incidental or consequential damages (including loss of use, loss of profit and claims of third parties) however caused, whether by the negligence of Pelco or otherwise.

The above warranty provides the Dealer with specific legal rights. The Dealer may also have additional rights, which are subject to variation from state to state.

If a warranty repair is required, the Dealer must contact Pelco at (800) 289-9100 or (559) 292-1981 to obtain a Repair Authorization number (RA), and provide the following information:

1. Model and serial number
2. Date of shipment, P.O. number, Sales Order number, or Pelco invoice number
3. Details of the defect or problem

If there is a dispute regarding the warranty of a product which does not fall under the warranty conditions stated above, please include a written explanation with the product when returned.

Method of return shipment shall be the same or equal to the method by which the item was received by Pelco.

#### RETURNS

In order to expedite parts returned to the factory for repair or credit, please call the factory at (800) 289-9100 or (559) 292-1981 to obtain an authorization number (CA number if returned for credit, and RA number if returned for repair).

All merchandise returned for credit may be subject to a 20% restocking and refurbishing charge.

Goods returned for repair or credit should be clearly identified with the assigned CA or RA number and freight should be prepaid. Ship to the appropriate address below.

*If you are located within the continental U.S., Alaska, Hawaii or Puerto Rico, send goods to:*

Service Department  
Pelco  
3500 Pelco Way  
Clovis, CA 93612-5699

*If you are located outside the continental U.S., Alaska, Hawaii or Puerto Rico and are instructed to return goods to the USA, you may do one of the following:*

If the goods are to be sent by a COURIER SERVICE, send the goods to:

Pelco  
3500 Pelco Way  
Clovis, CA 93612-5699 USA

If the goods are to be sent by a FREIGHT FORWARDER, send the goods to:

Pelco c/o Expeditors  
473 Eccles Avenue  
South San Francisco, CA 94080 USA  
Phone: 650-737-1700  
Fax: 650-737-0933

### REVISION HISTORY

Manual #	Date	Comments
C1448M	6/96	Original version.
	7/96	Added models DF8-2 and DF8-3.
	7/97	Maximum camera and lens dimensions changed per PAR 97031.
	2/98	Added DF8-1 model. Revised Sections 3.0, 4.0 and 5.0. Updated manual to new format.
C1448M-A	1/99	Extensive revisions resulting from the redesign of the DF8 back box to the DF8A back box.
C1448M-B	8/00	Added note per ECO 00-6161. Changed instructions and layout to new format.
C1448M-C	8/02	Added certifications and <i>Important Safeguards and Warnings</i> .

Pelco, the Pelco logo, Spectra, Genex, Legacy, Esprit, and Camclosure are registered trademarks of Pelco. Endura and ExSite are trademarks of Pelco

© Copyright 2002, Pelco.  
All rights reserved.