

OPERATING AND INSTALLATION INSTRUCTIONS

Model B-195

GAS FIRED AUTOMATIC INSTANTANEOUS BOOSTER WATER HEATER



FOR YOUR SAFETY

Do not store or use gasoline or other flammable vapors and liquids or other combustible materials in the vicinity of this or any other appliance. To do so may result in an explosion or fire.

WARNING: Improper installation, adjustment, alteration, service or maintenance can cause property damage, personal injury or loss of life. Refer to this manual. Installation and service must be performed by a qualified installer, service agency or the gas supplier.

FOR YOUR SAFETY

WHAT TO DO IF YOU SMELL GAS

- *Do not try to light any appliance.
- *Do not touch any electrical switch; do not use any phone in your building.
- *Immediately call your gas supplier from a neighbor's phone. Follow the gas supplier's instructions.
- *If you cannot reach your gas supplier, call the fire department.

This manual should be maintained in legible condition and kept adjacent to the heater or kept in a safe place for future reference.



Raypak[®]

A Rheem[®] Company

Product Discontinued December 2003

P/N 240707

CONTENTS

PAGE	DESCRIPTION
3	1. RECEIVING EQUIPMENT
3	2. GENERAL SPECIFICATIONS AND DIMENSIONS
4	3. INSTALLATION PROCEDURES
4	- Code Requirements
4	- Combustion/Ventilation Air
5	- Venting
8	- Gas Piping
8	- Water Piping
11	- Electrical Wiring
12	4. START-UP AND OPERATION
12	- Component Location
12	- Sequence of Operation
12	- START-UP Procedures.
16	5. SERVICING UNIT
16	- Trouble Shooting Guide
	- Maintenance
18	6. PARTS
19	- Illustrated Parts
20	- Parts List
23	WARRANTY

These instructions are provided to assure the proper installation, operation and maintenance of the Raypak Booster Heater. Should questions arise regarding the specification, installation, operation or servicing of the unit, contact the local distributor or contact the Raypak factory.

CALIFORNIA PROPOSITION 65 WARNING: This product contains chemicals known to the State of California to cause cancer, birth defects or other reproductive harm.

1. RECEIVING EQUIPMENT

On receipt of your equipment it is suggested that you visually check for external damage to the carton. If the carton is damaged, it is suggested that a note be made on the Bill of Lading when signing for equipment. Remove the heater from the carton and if it is damaged report the damage to the carrier immediately. Be sure that you receive the number of packages indicated on the Bill of Lading. Claims for shortages and damages must be filed with the carrier by consignee.

Purchased parts are subject to replacement only under the manufacturer's limited warranty. Debits for defective replacement parts will not be accepted and defective parts will be replaced in kind only per our standard warranties.

When ordering parts, you must specify Model and Serial Number of heater. When ordering under limited warranty conditions, you must also specify date of installation.

Raypak recommends that this manual be reviewed thoroughly before installing your Raypak Heater. If there are any questions which this manual does not answer, please contact your local Raypak Representative.

2. GENERAL SPECIFICATIONS

The Raypak Booster Heater is design certified and tested under the requirements of the American National Standard, **ANSI Z 21.10.3**, and the Canadian National Standard, CAN 1-4.3-M85, and bears the National Sanitation Foundation, **NSF**, seal.

The Raypak Booster Heater is an instantaneous tube type free standing unit intended for use as a supplier of 180 Deg. F dishwasher rinse water. Inlet water temperature to the heater of 140 deg. F is required for optimum operation of the heater.

Water enters the heat exchanger from the heater inlet water connection. The water then is circulated through two passes of copper finned tubes, through a stainless steel tank and to the dishwasher. Water is also re-circulated through a bypass system that assures the availability of the proper temperature water at the heater outlet.

SPECIFICATIONS AND DIMENSIONS

Model	Input MBH	GPH Delivery at Indicated Temperature Rise							
		40°F	50°F	60°F	70°F	80°F	100°F	120°F	140°F
B-195	195	490	392	327	280	245	196	163	140

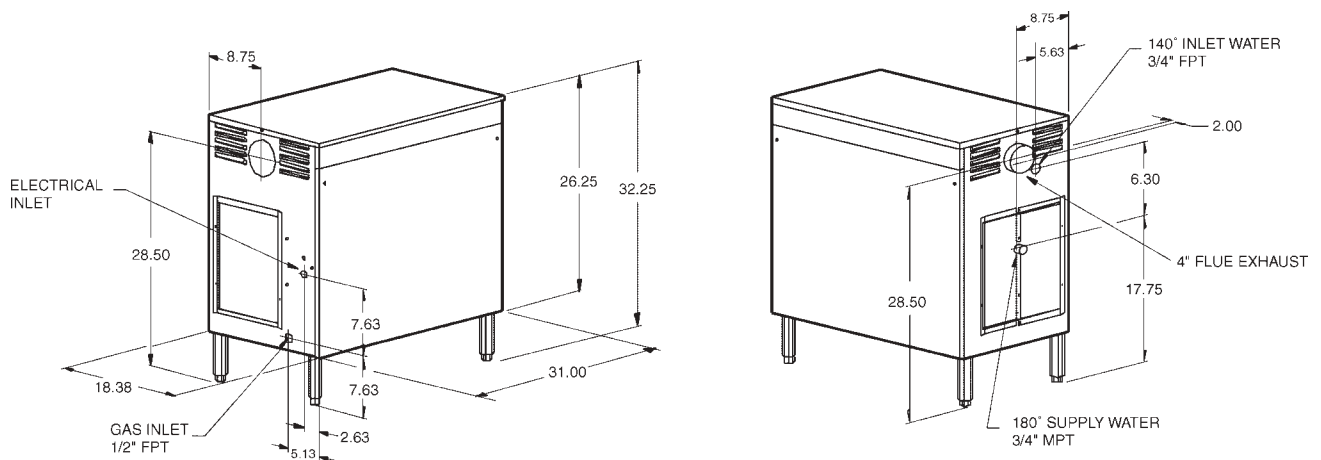

Fig #9165

3. INSTALLATION PROCEDURES.

CODE REQUIREMENTS

Installation must be in accordance with local codes, or in the absence of local codes with the latest edition of the National Fuel Gas Code, **ANSI Z223.1**, the National Electrical Code, **ANSI/NFPA 70**. For Canada, **CAN/CGA B149.1 and .2**, and **CSA C22.2 No. 1**.

LEG INSTALLATION

Four (4) legs are supplied loose within the carton for installation at the site. This will provide the required six-inch clearance off the floor. To install the legs, raise one end of the heater just high enough to allow the legs to be screwed into the two corners of that end. Make sure each leg is tightened securely by hand. Lower the heater gently to minimize any undue strain on the two (2) legs. Gently raise the other end, and repeat the same procedure for the other two (2) legs. Rotate the lower section of each leg as necessary to level the heater in place.

Booster water heater should not be located in an area where water leakage will result in damage to the area adjacent to it or to lower floors of the structure. Where such areas cannot be avoided, it is recommended that a suitable catch pan, adequately drained, be installed under this heater. Do not install directly on carpeting.

CLEARANCE REQUIREMENTS

Floor	Top	Left Side	Right Side	Front	Back	Vent
*	0"	6"	6"	Alcove	6"	1"

*Approved for installation on combustible flooring.

A front clearance of at least 24" is recommended for adequate service of burner-tray and controls.

COMBUSTION/VENTILATION AIR

B195 COMBUSTION AIR ADJUSTMENT

This model is equipped with an air adjustment screw on the combustion air blower inlet. For natural gas the opening is factory set at about 2.12" diagonal dimension, for propane gas the opening is 1.875" diagonal dimension, which should be the proper setting for most installations. However, field conditions including unusual gas characteristics may create a need for adjustment to achieve optimum performance. When the combustion air setting is proper, there will be some lifting of the flames on some areas of the burner tile under cold start conditions. After about five minutes of operation, the flames should settle down and blue tips should become visible on some areas and orange glow on other sections of the burner tile. Lifting of flames beyond five minutes would indicate too much combustion air. The adjustment screw should be turned clockwise to reduce the combustion air supply until the lifting settles down. If the blue tips disappear and the entire burner surface becomes radiant white, it indicates that there is not enough combustion air and the adjustment screw should be turned counterclockwise to increase the combustion air opening until the blue tips and orange glow become visible again.

The optimum excess air will result in CO₂ levels between 8 and 8.5% for natural gas and 9.2 to 9.7% for propane. If a flue gas analyzing equipment is available, the opening can be adjusted to achieve this CO₂ level. Or, if an inclined manometer is available, pressure measured at the combustion air switch pressure tap, can be set at -0.35" W.C. for natural gas and -0.60" W.C. for propane by means of the adjustment screw. Pressure at this level will result in the proper CO₂ levels mentioned above.

Again, the factory setting will be adequate for most field conditions and adjustment will not normally be required.

CAUTION: *A dusty kitchen environment combined with greasy laden air will clog the combustion air blower wheel and cause premature failure of the heater. Combustion air must not be contaminated by corrosive chemical fumes which can severely damage the heater.*

Measures must be taken to prevent the entry of corrosive chemical fumes to the combustion and ventilation air supply. Such chemicals include, but are not limited to, chlorinated and/or fluorinated hydrocarbons such as found in refrigerants, aerosol propellants, dry-cleaning fluids, degreasers, and paint removers. Other harmful elements may come from bleaches, air fresheners, or mastics. Vapors from these types of products can form corrosive acid compounds when burned in a gas flame. The resulting acid condensate can damage or substantially reduce the life of the heater. It may be necessary to provide outside air directly to the heater in order to avoid this problem.

An adequate supply of air for proper combustion and ventilation must be provided in accordance with **Sec. 5.3** of the National Fuel Gas Code, **ANSI Z223.1**, or applicable provisions of the local building codes.

Do not obstruct the flow of combustion and ventilation air to the heater.

VENTING

The vent pipe must be the same size or larger than the 4" diameter outlet on the heater. The standard vent outlet is on the right side, but this can be changed to the left side by reversing the orientation of the flue collector box. This can be done easily in the field. Remove the top casing cover to gain access to the flue collector box. Remove the screws along the sides of the flue collector. Disconnect the vent switch tubing from the fitting and remove the fitting from the flue collector box. Lift the box and turn around the other direction. Remove the stainless steel plug button and install the fitting in its place; then install the plug button where the fitting was removed. Reconnect the vent switch tubing to the fitting. Replace and secure the flue collector box with the screws previously removed.

The maximum flue gas temperature at the heater outlet is less than 400 degrees F. Use only the special gas vents listed for use with Category III gas burning heaters, such as the stainless steel Saf-T Vent manufactured by Heat-Fab, Inc. (800-772-0739), or the StaR-34 stainless steel gas vents manufactured by Flex-L International, Inc. (800-561-1980), or the FasNSeal stainless steel gas vents manufactured by ProTech Systems, Inc. (800-766-3473). A special adapter may be required. Pipe joints must be positively sealed. Follow carefully the vent manufacturers' installation instructions.

WARNING: Provide a screen or barrier to prevent personal injury in areas where personnel contact with vent pipe can occur; but **DO NOT INSULATE** the vent pipe, nor use means that will restrict thermal expansion or movement of the vent.

VENTING THROUGH TYPICAL EXHAUST SYSTEM

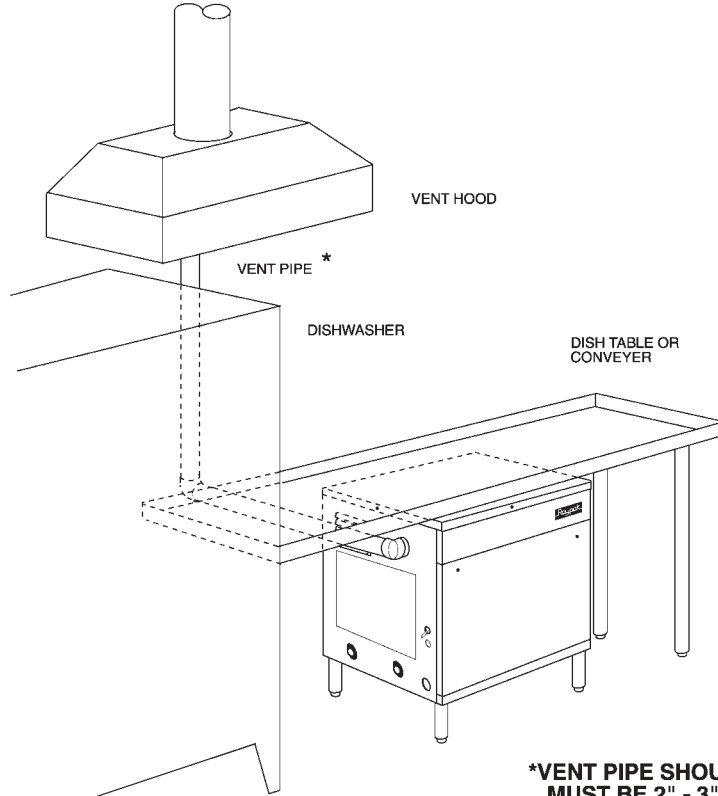

***VENT PIPE SHOULD NOT PENETRATE FILTER. MUST BE 2" - 3" ABOVE SKIRT BOTTOM.**

Applies only to exhaust hood over cooking equipment.

TYPICAL THRU - THE - WALL VENTING

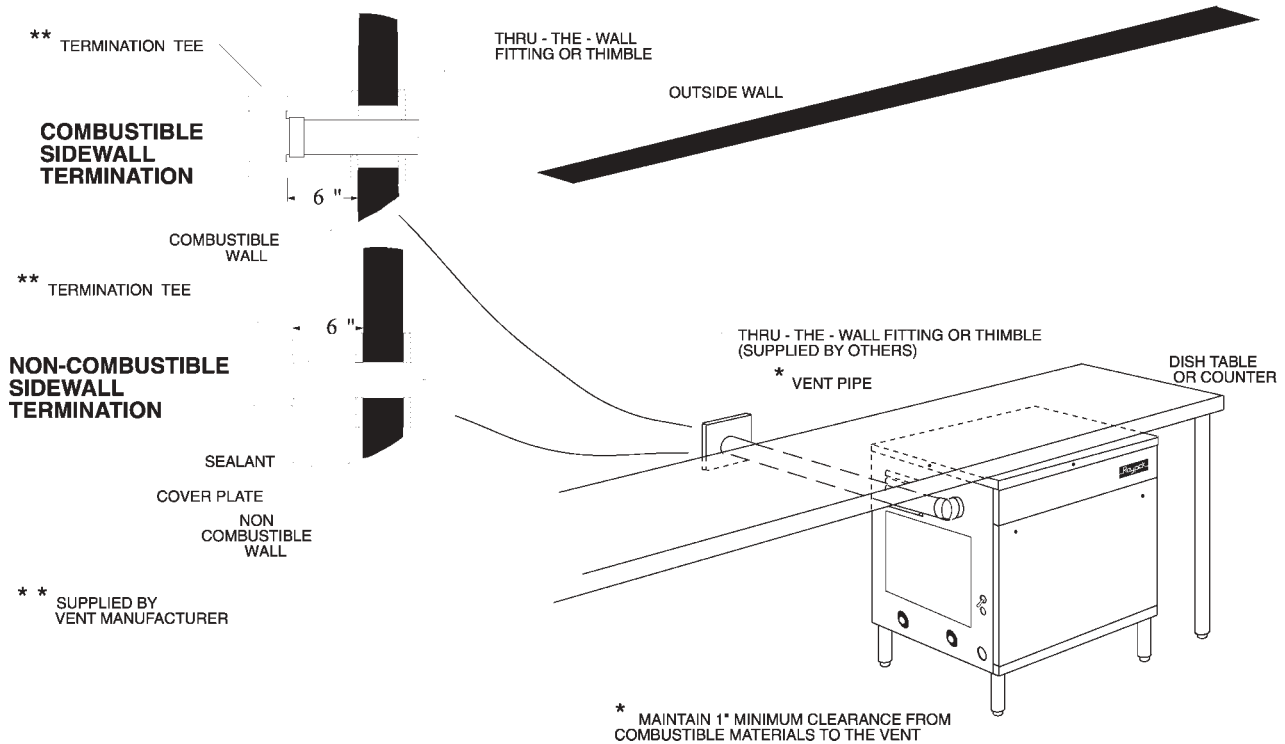

Fig. #8975.3

All horizontal runs of the vent pipe shall have a minimum rise of 1/4" per foot of length and should be supported at maximum intervals of 5 feet (for Canada, 3 feet) and at each point where an elbow is used.

For horizontal venting, the total length of 4-inch diameter pipe shall not exceed 30 feet with up to two 90° elbows and 1 termination vent. For each additional elbow, reduce the total pipe length by 10 feet. The minimum length, in either case, is 2 feet with two elbows ending in a termination vent. For vertical venting, the lengths described above should be followed, with a termination vent at the top. The minimum length is 5 feet with up to two elbows and a termination vent.

For sidewall venting, locate the heater as close as possible to the wall being used. The maximum and minimum wall thickness is determined by the wall thimble available from the vent manufacturer. Refer to the vent manufacturer installation instructions.

Additional requirements when venting through a sidewall:

1. The vent terminal shall be located at least three feet above any forced air inlet located within ten feet; or at least four feet below, four feet horizontally from, or one foot above any door, window, or gravity air inlet into any building. It shall also have a minimum horizontal clearance of four feet from electric meters, gas meters, regulator and relief equipment.
2. The vent terminal shall be located not less than seven feet above grade when it is adjacent to public walkways.
3. The bottom of the vent terminal shall be located at least twelve inches above grade or ground, or normally expected snow accumulation level. The snow level may be higher on walls exposed to prevailing winds.
4. Avoid areas where local experience indicates that condensate drippage may cause problems such as above planters, patios, or over public walkways, or over an area where condensate or vapor could create a nuisance or hazard, or could be detrimental to the operation of regulators, relief valves, or other equipment.

The gas booster heater may be vented 3 ways:

1. Through the sidewall, or the ceiling, as discussed previously.
2. Into the exhaust system. (See illustration on page 6) Vent pipe must not penetrate filter.

When the unit is vented into the exhaust system, an electrical inter-lock must be provided to allow the flow of gas to the booster heater burner ONLY when the exhaust system is energized.

3. Free vented into a room or space where other gas fired equipment is installed, provided that one or more of the other installed equipment is furnished with a venting system or other approved means for removing the vent gases so the aggregate input of the remaining unvented equipment, including the booster heater, does not exceed 20 BTU per hour per cubic foot of volume. The volume of a room or space directly connected by a doorway, archway or other opening of comparable size that cannot be closed, may be included in the calculations. Refer to the National Fuel Gas Code ANSI Z223.1, NFPA 54.

GAS PIPING

The gas inlet pipe size is 1/2" NPT to the gas valve. Provide an adequate size gas supply line. The line should not be smaller than 1/2" NPT according to the chart below.

MAXIMUM EQUIVALENT PIPE LENGTH (FEET)

Gas	Pipe Size		
	1/2"	3/4"	1"
Natural	5	30	100
Propane		70	180

Gas piping must have a sediment trap ahead of the heater gas controls and a manual shut-off valve located outside the jacket. A manual shut-off valve is provided loose and must be installed at the site.

The heater and its gas connection shall be leak tested before placing the heater in operation.

The heater and its individual shut-off valve must be disconnected from the gas supply piping system during any pressure testing of that system at test pressures in excess of 1/2 psig (3.5 kPa).

The heater must be isolated from the gas supply piping system by closing its individual manual shut-off valve during any pressure testing of the gas supply piping system at test pressures equal to or less than 1/2 psig (3.5 kPa).

Dissipate test pressure from the gas supply line before re-connecting the heater and its manual shut-off cock to the gas supply line. **FAILURE TO FOLLOW THIS PROCEDURE MAY DAMAGE THE GAS VALVE. OVER PRESSURED GAS VALVES ARE NOT COVERED BY THE WARRANTY.** The heater and its gas connections shall be leak tested before placing the appliance in operation. Use soapy water for leak test. **DO NOT** use open flame.

NOTE: DO NOT use teflon tape on gas line pipe threads. A flexible sealant suitable for use with Natural and Propane gases is recommended.

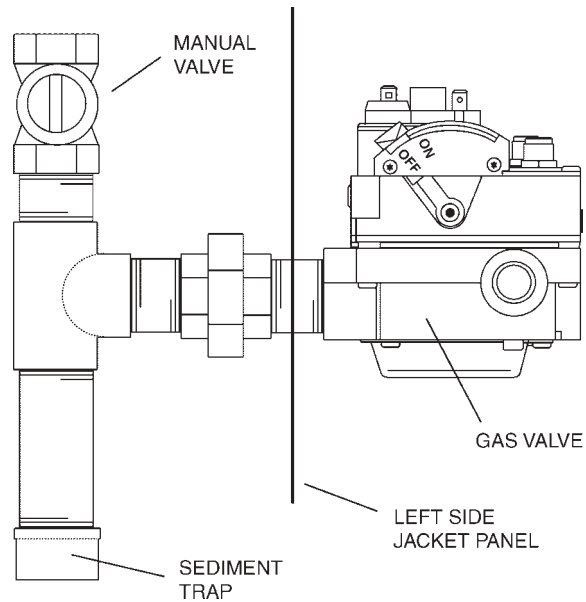

Fig. # 8984

GAS PRESSURE SPECIFICATIONS

Gas	Inches W.C.		
	Min	Max	Manifold
Natural	4.5	10.5	3.5
Propane	11.0	14.0	10.0

The maximum inlet gas pressure must not exceed the value shown above. The minimum gas pressure shown is for the purposes of input adjustment.

The gas valve is provided with a pressure tap to measure the gas pressure downstream, which is also the manifold pressure.

WATER PIPING

The inlet and outlet water connections are 3/4 in. NPT. A water pressure regulator is shipped loose with the heater. Install, as needed, between the booster heater and dishwasher lines. Adjust setting to maintain 20 PSI at the dishwasher.

Install a suitable water hammer arrester between the booster heater and dishwasher, as shown on page 10, typical piping.

A drain valve is provided in the tank for draining water during servicing.

The temperature and pressure relief valve is easily accessible through the front. A nipple is provided (shipped loose with the heater) for installation in the T & P relief valve. A drain line must be connected to the nipple and run to a safe place of disposal.

WARNING: *Failure to do so can cause water damage or burns due to scalding if the relief valve should open. Drain line must be as short as possible, pitch downward from the relief valve, and have the same size as the valve discharge connection through-out its entire length. Refer to tag attached to T & P relief valve.*

The temperature and pressure relief valve should be manually operated at least once a year to insure that the valve mechanism is still functional. Repair or alteration of valve in any way is prohibited by National Safety Standards and or local codes.

If the relief valve discharges occasionally or periodically, this may be due to thermal expansion in a closed water supply system. Contact the water supplier or the local plumbing inspector on how to correct this situation. DO NOT plug the relief valve or install a shut-off valve in the discharge drain line.

The heater is equipped with a circulator to provide the minimum water flow in the heater, and maintain a uniform water temperature in the tank. Depending on heater distance from the dishwasher, it may be necessary to run empty rack(s) to purge supply of line lower than the required 180°F water temperature. For this reason, it is best to locate heater as close as possible to the dishwasher.

CAUTION: In severe cold weather, freezing air can be drawn through the vent pipes to the heat exchanger during overnight shut-down period. If there is no water circulation or heat in the water, freezing can occur which will damage the heat exchanger. To avoid freezing damage, constant water circulation should be maintained by keeping the booster heater energized so that the circulator (pump) will run. Closing the manual gas shut-off valve will prevent unnecessary heating of the water. **NOTE:** Under this condition, the ignition system will go into a lock-out mode. To resume service, the heater will need to be reset by momentarily turning the ON/OFF switch to the OFF position, and then to the ON position.

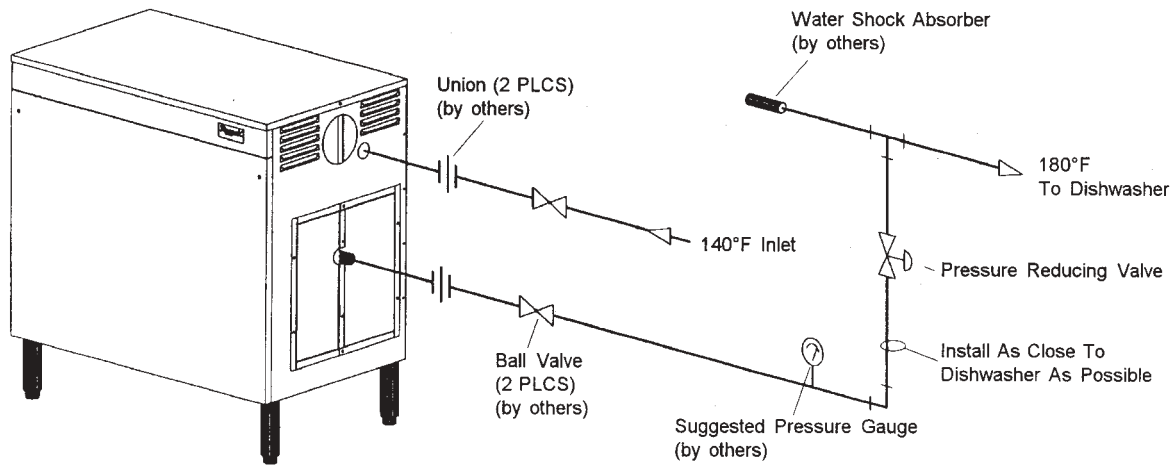

Fig. #9153

TYPICAL PIPING

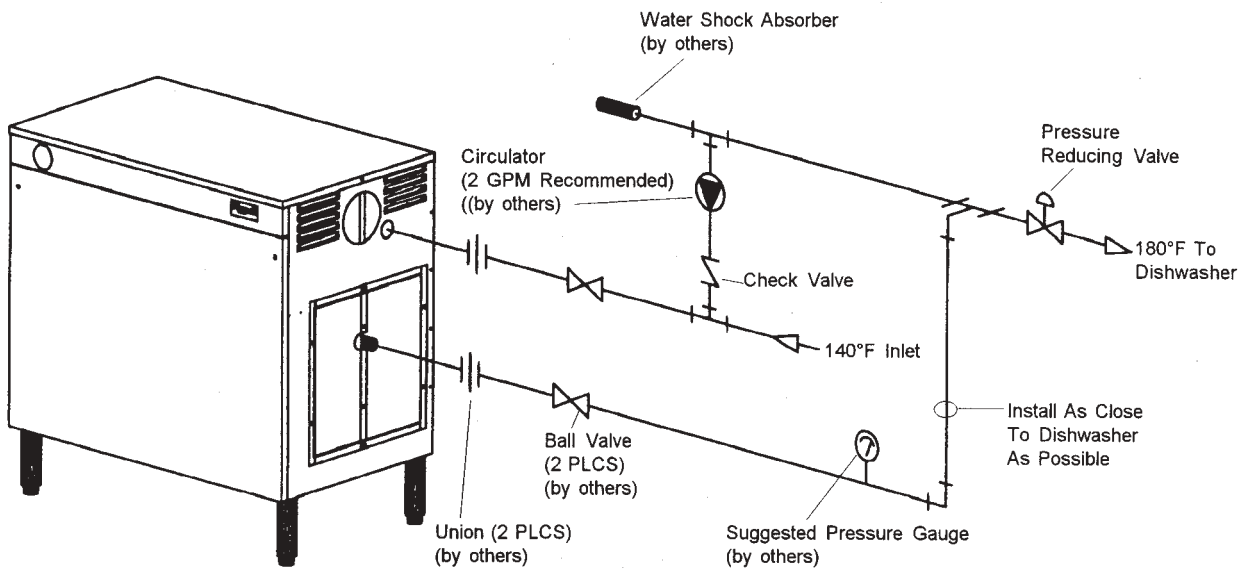

Fig. #9154

TYPICAL PIPING FOR RECIRCULATION SYSTEM
WHEN BOOSTER HEATER IS GREATER THAN 10 FEET FROM DISHWASHER

ELECTRICAL

The electrical power supply requirement for the heater is 120 volts, 60 Hz, 5.0 amps or less . Field wiring connections and electrical grounding must comply with the local codes, or in the absence of local codes, with the latest edition of the National Electrical Code, **ANSI/NFPA 70**.

NOTE: Polarity must be observed for the heater to operate properly. Consult wiring diagram. Provide a separate fused circuit from the main electrical panel to the heater and a disconnecting means within sight of the heater.

Remove the control box cover and make the power supply connection in the field wiring compartment. The pump and blower supplied with the heater are pre-wired and operate with the heater control system.

NOTE: If it is necessary to replace any of the original wiring it must be replaced with 105° C rated wire or its equivalent.

LADDER DIAGRAM

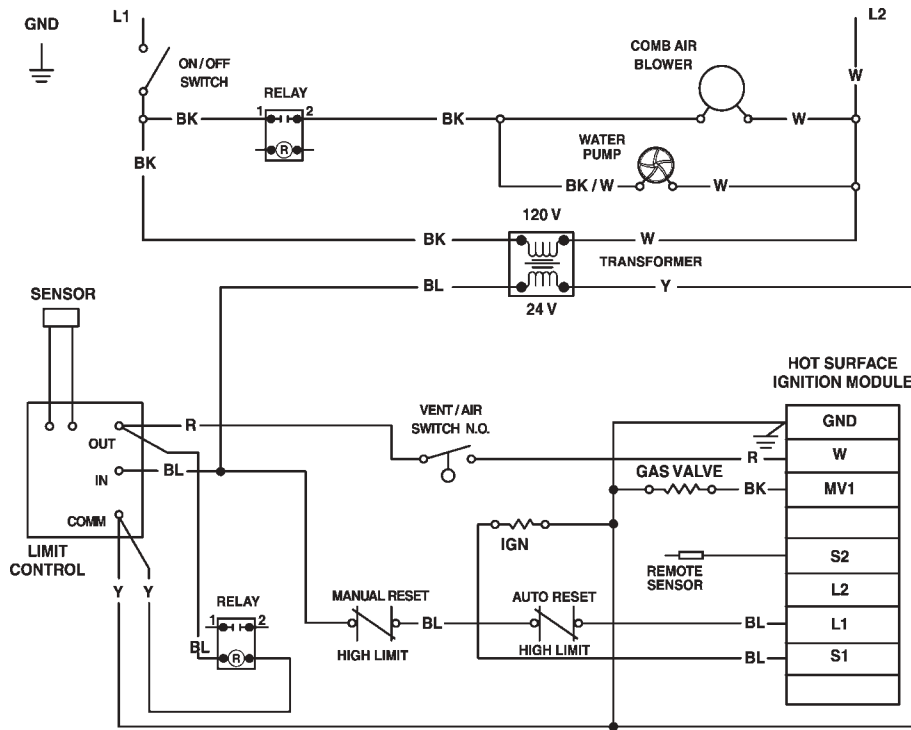

CONNECTION DIAGRAM

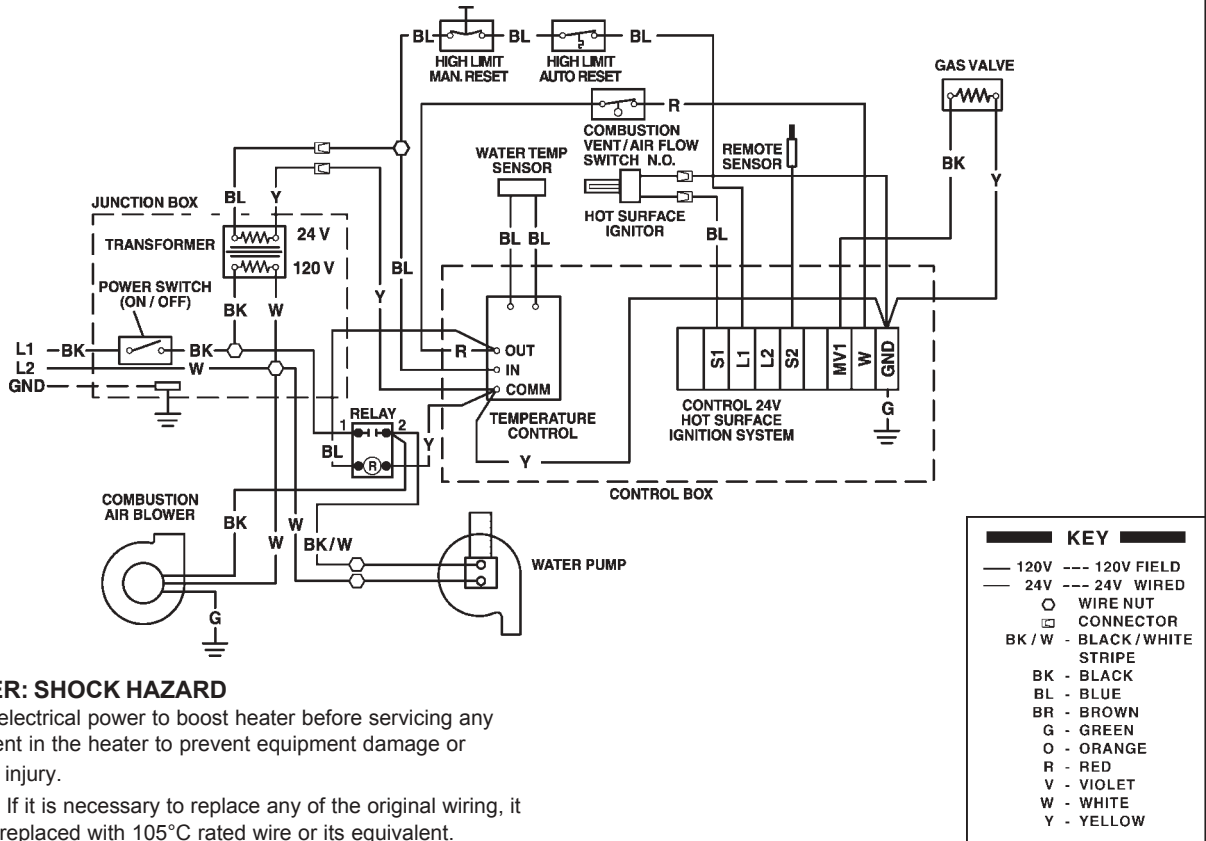

DANGER: SHOCK HAZARD

Turn off electrical power to boost heater before servicing any component in the heater to prevent equipment damage or personal injury.

NOTE: If it is necessary to replace any of the original wiring, it must be replaced with 105°C rated wire or its equivalent.

4. START UP AND OPERATION

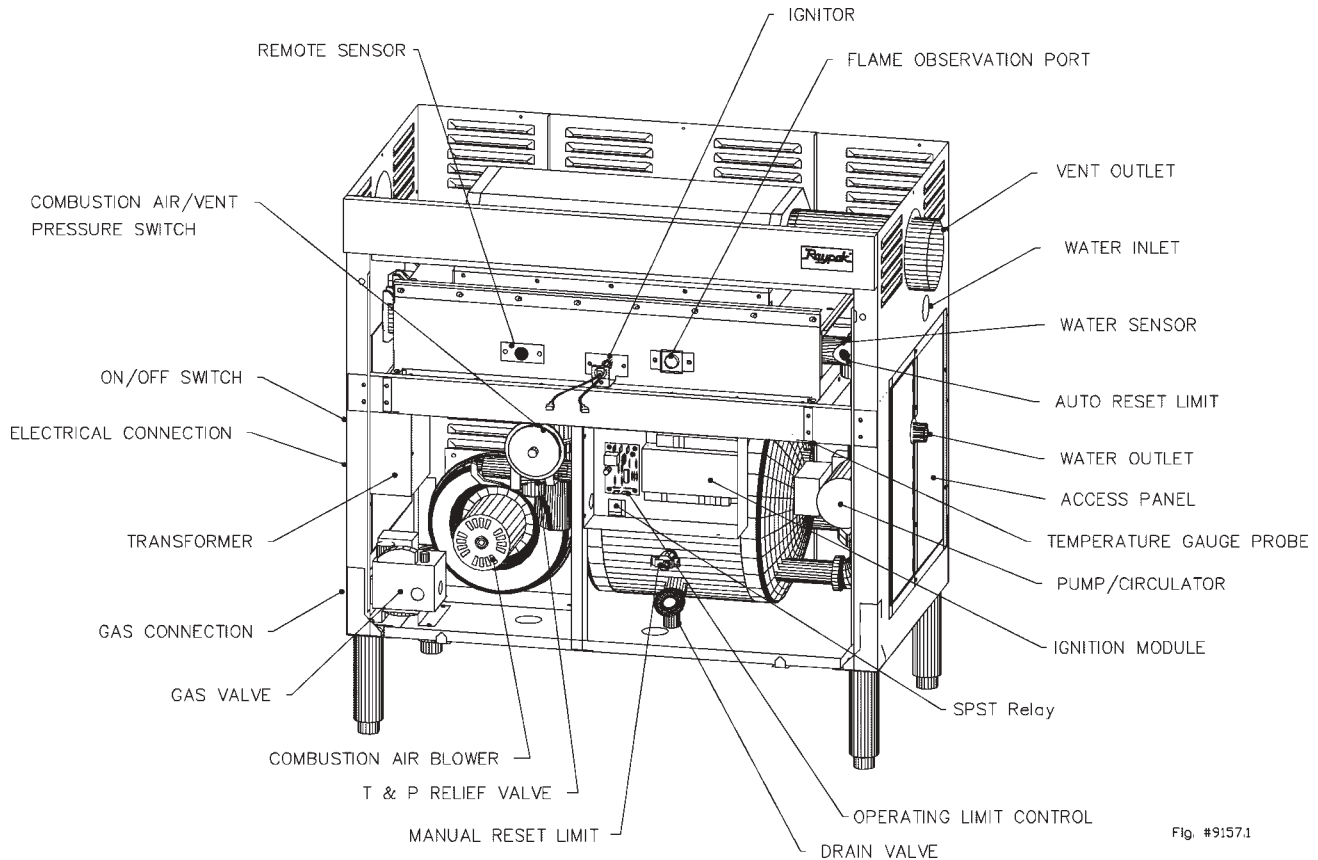

COMPONENT LOCATION

SEQUENCE OF OPERATION

The booster heater is designed to maintain a temperature of 180 deg. F (82.2 Deg. C) of 490 GPH water required for the rinse cycle of a commercial dishwasher. An inlet temperature of 140 Deg. F (60 Deg. C) will produce optimum results.

Provided the necessary power, water, gas and vent connections are completed, the unit is started by the activation of the on/off switch located on the left side panel. The blower motor and the circulator pump will also start.

Providing the operating and safety controls including the vent switch is closed, the ignition module will energize the ignitor. The hot surface ignitor then heats up, and is proven to be capable of ignition. The gas valve is then energized. The burner will be lit and the remote sensor will sense the flame. If the burner flame is not sensed within four seconds the gas valve will shut off. The ignition module will try for a total of three cycles to prove ignition. If, after third cycle ignition is not proven, the module will go into lockout, and a Red-LED will start blinking. To recycle the burner, momentarily turn the power switch to the off position and then to the on position. When the water temperature exceeds the setting of the operating controller, the burner will shut

off until the next call for heat. The operating limit control is factory set at 185°F. Combustion air blower and the circulator pump will cycle On/Off with the operating limit controller.

START UP PROCEDURES

SECTION 1. FILLING THE SYSTEM

Fill the heater system with water purging all air. It is recommended that the system be flushed before putting heater into operation. This can be done by opening the drain valve located under the stainless steel tank.

SECTION 2. CHECKING CIRCULATOR/PUMP

Before lighting the heater, make sure the circulator is operating properly. With the gas valve in the off position, activate the power switch. The circulator should start immediately. Allow the circulator to pump the water through the system.

NOTE: The circulator motor does not require lubrication.

SECTION 3. LIGHTING THE HEATER

Safety lighting and other performance criteria were met for the burner assembly and control assembly when the heater was tested for design certification under the ANSI Z21.10.3 Standard

WARNING: *If you do not follow these instructions exactly, a fire or explosion may result causing property damage, personal injury or loss of life.*

- A. This heater **DOES NOT** have a pilot. It is equipped with a hot surface ignition device which automatically lights the burner. **DO NOT** attempt to light the burner by hand.
- B. Before operating smell all around the heater area for gas. Be sure to smell next to the floor because some gases are heavier than air and will settle on the floor.

WHAT TO DO IF YOU SMELL GAS

- Do not try to light any appliance.
 - Do not touch any electric switch.
 - Do not use any phone in your building.
 - Immediately call your gas supplier from a neighbor's phone. Follow the gas supplier's instructions.
 - If you cannot reach your gas supplier, call the fire department.
- C. Use only your hand to push in, move or turn the gas control knob or lever. Never use tools. If the knob or lever will not push in, move or turn by hand, don't try to repair it, call a qualified service technician. Force or attempted repair may result in a fire or explosion.
 - D. Do not use this heater if any part has been under water. Immediately call a qualified service technician to inspect the heater and to replace any part of the control system and gas control which has been underwater.

HOT SURFACE IGNITION MODELS WITH ROBERTSHAW GAS VALVE

1. **STOP!** Read the safety information.
2. Turn off all electrical power to the appliance.
3. Remove front door and control box cover.

4. This appliance is equipped with an ignition device which automatically lights the burners. Do not try to light the burners by hand.
5. Push in and move gas control lever counter clockwise ← to "OFF" position.
6. Wait five (5) minutes to clear out any gas. If you then smell gas. STOP! Follow "B" in the safety information above on this label. If you don't smell gas, go to next step.
7. Move gas control lever clockwise → to "ON" position.

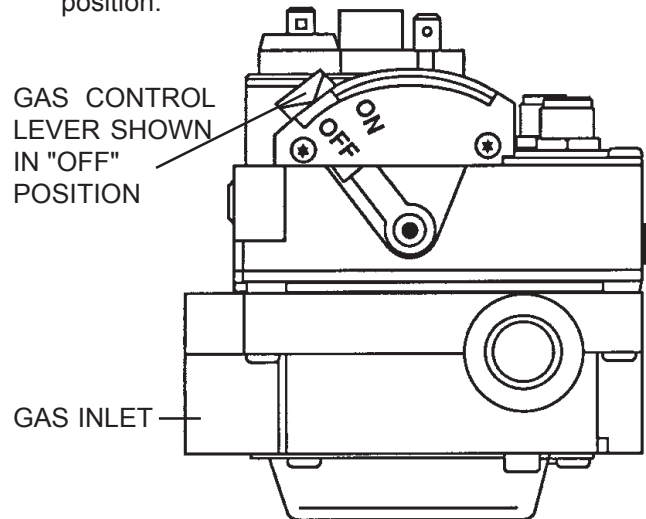

8. Replace control box cover and front door.
9. Turn on all electric power to the appliance.
10. If the appliance will not operate. Follow the instructions "To Turn Off Gas To Heater" and call your service technician or gas supplier.

TO TURN OFF GAS TO HEATER

1. Turn off all the electric power to the heater if service is to be performed.
2. Remove front door and control box cover.
3. Push in and move gas control lever counter clockwise ← to "OFF".

CAUTION: *Should overheating occur or the gas supply fails to shut off, DO NOT turn off or disconnect the electrical supply to the pump. Instead, shut off the gas supply at a location external to the appliance. Failure to observe this precaution may aggravate the overheated condition resulting in possible damage to the heater and injury to the user.*

SECTION 4. TESTING THE IGNITION SAFETY SHUT-OFF

The ignition system safety shut-off must be tested by conducting the following method of tests:

- a) With the system power off, manually shut off the gas supply.
- b) Turn power back on, observe the igniter start to heat up and glow bright orange.
- c) After about four (4) seconds, the gas valve is energized, then de-energizes, after the third try the module goes into a safety lockout a few seconds later. Igniter will stop glowing and the Red LED on the module will start blinking.
- d) Manually reopen the gas supply. No gas should be flowing into the main burners. End of test.
- e) To reset the system, momentarily shut off power switch then turn it back on again. Igniter will start to heat up and normal heating cycle will occur as described in the sequence of operation on page 12.

MAINTENANCE INSTRUCTIONS

1. The water pump motor and the combustion air blower motor are permanently lubricated and requires no other maintenance.
2. Venting system for this heater may be equipped with high temperature plastic material rated for operation at 480°F maximum. Check for signs of deformation in the plastic vent pipes which will be an indication of excessive temperature and abnormal conditions in the venting system. Refer to the instructions supplied by the vent pipe manufacturer.
3. The burner is made of ceramic material and operates in the infrared mode. When the burner is operating properly very little blue flame will be visible due to the incandescent brightness of the ceramic material. This can be observed through the glass observation port hole.
4. Depending on the condition of the kitchen environment, the burner and blower wheel may require to be cleaned of lint or grease-laden dust. Inspect the burner box every six months. Refer to the Servicing Section related to burner removal.

BURNER INSPECTION/VISUAL

1. Shut-off electrical power and gas supply to the heater.
2. Disconnect wiring to hot surface ignitor and sensor.

3. Remove screws on burner access panel.
4. Remove refractory block.
5. Visually inspect burner tray panel.
6. Reverse above procedure to reinstall, checking burner tray and seal to prevent leakage.

ADJUSTMENTS/REPLACEMENTS OF COMPONENTS

CAUTION: Label all wires prior to disconnection when servicing controls. Wiring errors can cause improper and dangerous operation. Verify proper operation after servicing.

DANGER - SHOCK HAZARD - Make sure electrical power to the heater is disconnected to avoid potential serious injury or damage to components.

1. Gas Valve Replacement
 - a) Shut off electrical power and gas supply to the heater.
 - b) Remove gas piping to gas valve inlet.
 - c) Remove front panel and leftside access panel.
 - d) Disconnect flex hose gas line.
 - e) Disconnect wiring connections to gas valve.
 - f) Remove (2) screws holding gas valve.
 - g) Reverse above procedure to reinstall.

2. Hot Surface Ignitor Replacement
 - a) Shut off electrical power and gas supply to the heater.
 - b) Disconnect wiring leads to the igniter by pulling apart plastic connector plugs.
 - c) Remove bracket holding ignitor cylinder.
 - d) Reverse above procedure to reinstall.

CAUTION: Silicon carbide ignitor is fragile and brittle. Exercise extreme care in handling the assembly to avoid damage.

3. Ignition Module Replacement
 - a) Shut off electrical power to the heater.
 - b) Remove control cover screws and open control compartment.
 - c) Disconnect wiring connections to module.
 - d) Remove screws (2) holding module.
 - e) Reverse above procedure to reinstall.

4. Transformer Replacement
 - a) Shut off electrical power to the heater.
 - b) Remove control cover screws and open control compartment.
 - c) Disconnect wiring connections from transformer leads.
 - d) Remove screws (2) holding transformer.
 - e) Reverse above procedure to reinstall.

5. Limit Control Module
 - a) Shut-off electrical power to the heater.
 - b) Remove control cover screws and open control compartment.
 - c) Disconnect wiring connections to the board.
 - d) Carefully pull out the control board from the nylon pin supports.
 - e) Reverse above procedure to reinstall.
6. Sensor Probe Replacement
 - a) Shut off electrical power to the heater.
 - b) Shut off water supply to the heater and open drain valve to remove water to the sensor probe level.
 - c) Remove front panel and control box cover.
 - d) Disconnect wire leads from temperature control module.
 - e) Remove sensor probe from the header. Use 7/16" wrench.
 - f) Reverse above procedure to reinstall.
7. Manual Reset High Limit Control Replacement
 - a) Shut off electrical power and water supply to the heater.
 - b) Remove front panel and open drain valve to remove water to the limit control level in the tank.
 - c) Disconnect wiring connections to limit control.
 - d) Remove limit control from the tank. Use 1" hex wrench, being careful not to break plastic body.
 - e) Reverse above procedure to reinstall.
8. Auto Reset High Limit Replacement
 - a) Shut off electrical power and water supply to the heater.
 - b) Remove front panel and open drain valve to remove water to the limit control level in the header.
 - c) Disconnect wiring connections to limit control.
 - d) Remove limit control.
 - e) Reverse above steps to reinstall.
9. Air/Vent Switch Replacement
 - a) Shut off electrical power to the heater.
 - b) Remove front panel.
 - c) Remove wiring connections to switch.
 - d) Remove screws (2) holding the switch.
 - e) Reverse above procedure to reinstall.
10. Remote Sensor Replacement
 - a) Shut off electrical power & gas supply to the heater.
 - b) Remove front panel.
 - c) Disconnect wiring lead from sensor.
 - d) Remove the screws (2).
 - e) Reverse above procedure to reinstall.
11. Combustion Air Blower Replacement
 - a) Shut off electrical power to heater.
 - b) Remove front panel and access cover on left side of heater.
 - c) Remove screws (3) on blower housing mounting panel.
 - d) Drop down blower assembly from discharge connection.
 - e) Open field wiring box and disconnect blower wiring.
 - f) Reverse above steps to reinstall blower.
12. Pump/Circulator Replacement
 - a) Shut off electrical power to the heater.
 - b) Shut off water supply and open drain valve to remove water in the piping at the pump level.
 - c) Remove front panel and access panel on right side of cabinet.
 - d) Disconnect wiring and conduit connections to motor.
 - e) Remove plumbing connections to pump assembly.
 - f) Reverse above procedure to reinstall.
13. Temperature and Pressure Relief Valve Replacement.
 - a) Shut off electrical power to the heater.
 - b) Shut off water supply and open drain valve to remove water in the tank to the relief valve level.
 - c) Remove front panel.
 - d) Disconnect plumbing connections to the T & P relief valve.
 - f) Reverse above procedure to reinstall.

5. SERVICING UNIT

TROUBLE SHOOTING GUIDE

PROBLEM	POSSIBLE CAUSE	SUGGESTED SOLUTION
1. On-Off switch energized. Unit does not operate.	1a. No power to heater	a. Cycle the Power Switch off then on. -Check circuit breaker and electrical disconnect. -Check for reversed polarity and improper ground. -Check dishwasher vent interlock, if applicable.
	1b. Defective transformer	b. Check secondary voltage. If no 24 volts, replace transformer.
2. Pump/Blower NOT running.	2a. Loose wire(s)	2a. Check wiring connection(s) -Check pump amperage. If pump does not draw 0.67-0.78 amps, remove and inspect impeller.
	2b. Defective pump	2b. Replace cartridge or entire pump as needed.
	2c. Defective blower.	2c. Clean and inspect blower wheel. -Check operation. -Replace blower if needed
3. Unit energized, pump and blower running, but burner is <u>NOT</u> on.	3a. Limit control (operating limit) or sensor may be defective.	3a. If Red LED on circuit board is <u>ON</u> , check for a loose sensor connection or defective sensor. Sensor resistance readings: 60°F = 45,500± 2300 ohms 80°F = 28,000± 1300 ohms If Yellow LED is <u>ON</u> , water temperature is above set point. When either Red or Yellow LED is <u>ON</u> , heater will be shut down. Check 24V, power at OUT and COMM terminals. If no 24V is present when Red or Yellow LED is not <u>ON</u> , replace control board.
	3b. Blocked vent or defective air vent switch.	3b. Excessive vent length or resistance or blocked vent will open the air vent switch. Remove blockage. If switch stays open, replace air vent switch.
	3c. Tripped or defective manual reset limit.	3c. Depress the Manual Reset High Limit switch. -Ensure Operating Limit setting is 185°F or less. -Perform Pump Check Procedure. (High Limit trips may be due to a damaged pump). -Perform Operating Limit Check Procedure. -If High Limit will not reset, replace High Limit

Continuation TROUBLE SHOOTING GUIDE

3d. Excessive vent exhaust or defective air/vent switch.	3d. Excessive negative pressure exerted by the exhaust system on the vent will prevent N.O. combustion air/vent switch from closing. Provide means to relieve pressure and close the N.O. switch. If combustion air/vent switch will not close, replace switch.	
3e. Ignition module or igniter may be defective.	3e. Disconnect igniter leads from ignition module. Make sure 24V is present across ignition terminals on the ignition module during the ignition cycle. If not, replace ignition module. Check resistance reading across igniter leads. If circuit is open, or reading is greater than 30 ohms, replace the igniter. A new igniter will measure between 1 to 6 ohms at room temperature.	
3f. Gas valve or the ignition module may be defective.	3f. During the ignition cycle, 24V should be present at the MV1 and GND terminals for about 5 seconds. If no 24V is measured, replace the ignition module. If 24V is present, replace the gas valve.	
4. Unit energized, pump and blower running. Ignitor is glowing. Burners will not stay lighted.	4a. Improper ground 4b. Loose wiring. 4c. Remote sensor 4d. Insufficient gas pressure.	4a. Check ground connections inside control box. 4b. Check all connections and wire nuts. 4c. Check wire connection to remote sensor. 4d. Check gas pressure at outlet of valve under load, pressure should be: 3.5 in. W.C. for Natural gas 10.5 in. W. C. for Propane gas.
5 Unit does not produce sufficient hot water	5a. Supply water temperature too low. 5b. Dishwasher times not set properly. 5c. Operating limit set too low.	5a. Ensure supply water temperature is at least 140°F. 5b. Ensure dishwasher operates correctly. Check rinse cycle time and inspect spray nozzles for correct pressure setting or damage. 5c. Adjust operating limit to minimum temperature that provides 180°F rinse. (Do not set above 185°F). -Verify booster operates correctly, if not, recheck all procedures listed above.

6. REPLACEMENT PARTS LIST

NOTE: *To supply the correct part it is important that you state the model number, serial number and type of gas when applicable.*

Any part returned for replacement under standard company warranties must be properly tagged with RAYPAK return parts tag, completely filled in with the heater Serial Number, Model Number etc., and shipped to the Company freight prepaid.

If determined defective by the Company and within warranty, the part will be returned in kind or equivalent substitution, freight collect. Credit will not be issued.

**RAYPAK, INC.
2151 Eastman Avenue
Oxnard, CA 93030**

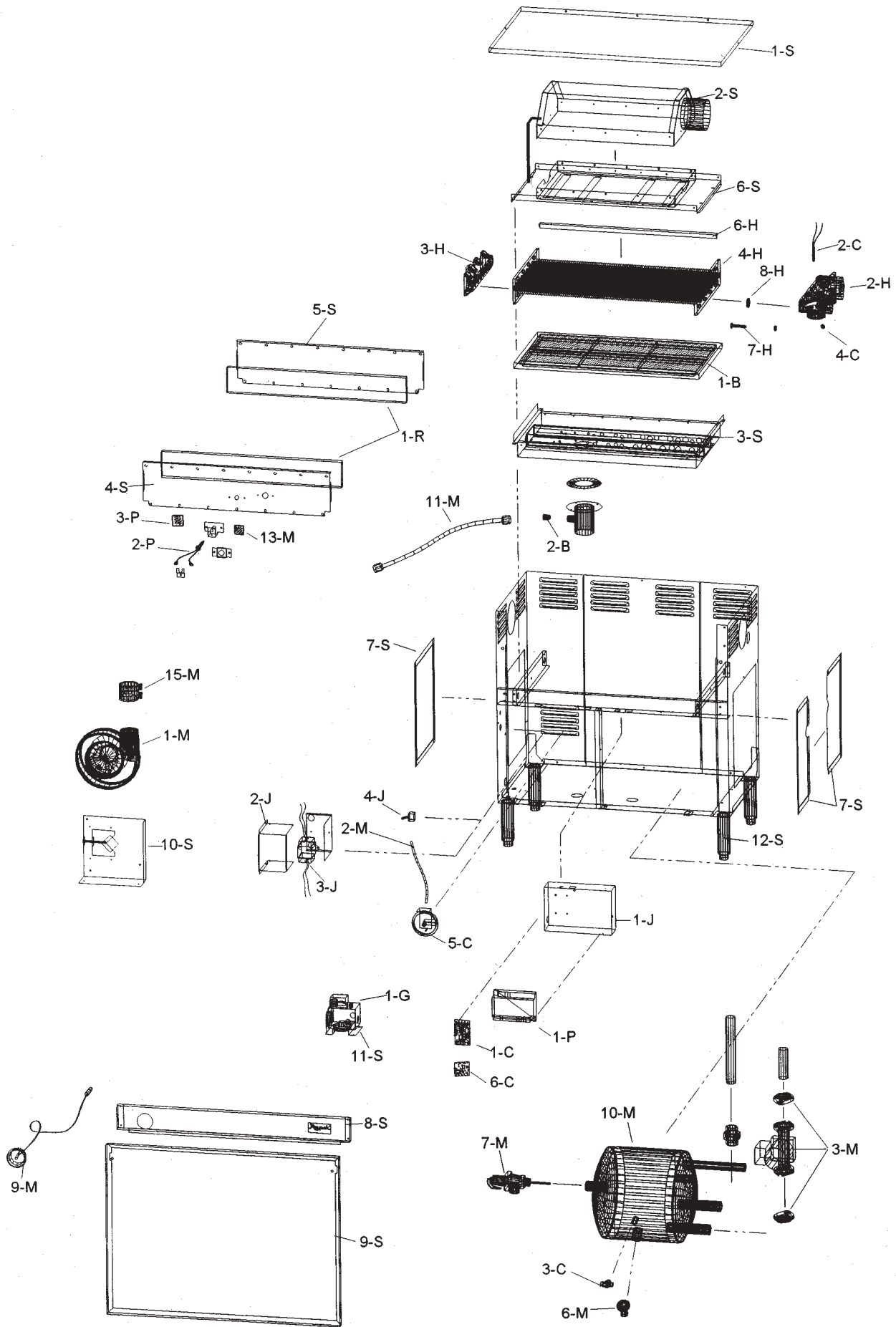

CALL OUT	DESCRIPTION	PART NO.
B	BURNER TRAY	
1-B	Burner Tray Complete Nat.	005704F
	Burner Tray Complete Pro.	006761F
2-B	Burner Orifice Nat. "N" Sea Level *	351204
	Burner Orifice Pro. #19 Sea Level *	351416
C	CONTROLS	
1-C	Operating Limit	005197F
2-C	Probe - Sensor	006532F
3-C	Manual Reset High Limit	008093F
4-C	Auto Reset High Limit	601270
5-C	Combustion Air/Vent Pressure Switch (N. O.)	651288
6-C	SPST (N.O.) Relay 24V	007377F
G	GAS VALVE	
1-G	Gas Valve, Nat.	006541F
	Gas Valve, Pro.	601170
2-G	Gas Valve Manual Shut-Off (Not Shown)	006543F
H	HEAT EXCHANGER	
1-H	Heat Exchanger Complete	005705F
2-H	Inlet/Outlet Header	005766F
3-H	Return Header	004982F
4-H	Tube Bundle	005706F
5-H	Heat Exchanger Tube	005707F
6-H	Baffle Kit	005708F
7-H	Carriage Bolt Kit	004248F
	Stud Bolt Kit	007911F
8-H	Header Gasket	005083B
J	CONTROL BOX	
1-J	Control Box Complete (Includes 1-C, 1-P)	005709F
2-J	Wiring Box	005725F
3-J	Transformer 24/120 50 VA	006533F
4-J	On/Off Switch	006531F
M	MISCELLANEOUS	
1-M	Blower	005710F
2-M	Air Pressure Switch Tubing	005712F
3-M	Pump	004990F
4-M	Pump Cartridge	951116F
5-M	Pump Flange Gasket	005191F
6-M	Drain Valve	501520
7-M	Temperature & Pressure Relief Valve	501753
8-M	Pressure Regulator (Not Shown)	006539F
9-M	Temperature Gauge (if equipped)	601157
10-M	Storage Tank 5 Gallon	005713F
11-M	Gas Flex Hose	005714F
12-M	Wire Harness	005715F
13-M	Inspection Window	005193F
14-M	Silicone Rubber Sealant (10oz)	005755F
15-M	Blower/Manifold Seal	005711F
16-M	Delimiting Kit	052871F

* For Altitudes Above 2000 Feet Above Sea Level, Consult Factory.

CALL OUT	DESCRIPTION	PART NO.
P	PILOT	
1-P	Ignition Control Module	005703F
2-P	Hot Surface Ignitor	005329F
3-P	Remote Sensor	601501
R	REFRACTORY	
1-R	Refractory Kit	005716F
S	SHEETMETAL	
1-S	Jacket Top (Stainless Steel)	005717F
2-S	Flue Collector	005720F
3-S	Combustion Box	005721F
4-S	Combustion Box Front Panel Kit	005722F
5-S	Combustion Box Rear Panel	005767F
6-S	Combustion Box Top Panel	005727F
7-S	Access Panel	005723F
8-S	Control Panel With Gauge Hole (Stainless Steel)	005718F
	Control Panel Without Gauge Hole (Stainless Steel)	006360F
9-S	Door (Stainless Steel)	005719F
10-S	Blower Mounting Panel	005728F
11-S	Gas Valve Mounting/Wrenching Bracket	005726F
12-S	Support Leg (1)	006217F

**LIMITED PARTS WARRANTY
COMMERCIAL BOOSTER HEATER**

SCOPE:

Raypak, Inc. ("Raypak") warrants to the owner that all parts of this booster heater, excluding controls and pump, will be free from failure under normal use and service for the specified warranty periods and subject to the conditions set forth in this Warranty. The Warranty is effective from date of original booster heater installation and satisfactory proof of the original installation date, such as installer invoice, is required. THIS WARRANTY WILL BE VOID IF THE HEATER IS NOT INSTALLED IN ACCORDANCE WITH LOCAL CODES AND ORDINANCES OR IF THE HEATER RATING PLATE IS ALTERED OR REMOVED OR IF THE HEATER IS MOVED FROM ITS ORIGINAL PLACE OF INSTALLATION.

HEAT EXCHANGER WARRANTY:

- Five (5) Years. This includes only the copper and bronze waterways.
- Twenty (20) Years against "Thermal Shock" (excluded, however, if caused by booster heater operating at large changes exceeding 150°F between the water temperature at intake and booster heater temperature, or operating at booster heater temperatures exceeding 200°F).

TOTAL FIVE YEAR STAINLESS STEEL TANK WARRANTY:

- First Year: Raypak will replace the tank if it fails under normal use and service.
- 2nd thru 5th Year: Raypak will replace the tank if it fails under normal use and service, provided that the owner must pay Raypak a portion of the published list price in effect at the time notice of the failure is given.

<u>YEAR OF CLAIM</u>	<u>REPLACEMENT PRICE (PERCENT OF LIST PRICE)</u>	<u>YEAR OF CLAIM</u>	<u>REPLACEMENT PRICE (PERCENT OF LIST PRICE)</u>
2	20%	4	60%
3	40%	5	80%

ANY OTHER PART MANUFACTURED BY RAYPAK:

One (1) Year Warranty, or eighteen (18) months from date of factory shipment based on Raypak's records, whichever comes first.

PARTS REPLACEMENT

Under this Warranty, Raypak will furnish a replacement for any failed part. Verification of the in-warranty failure will be made through inspection by a local recognized and certified service agency or the local Raypak representative at Raypak's option. The replacement part will be warranted for only the unexpired portion of the original warranty. Raypak makes no warranty whatsoever on the controls and the pump, but Raypak will apply any such warranties as may be provided to it by the part's manufacturer.

LABOR CHARGES

Labor charges to replace any failed part during the first 90 days of this Warranty, will be paid by Raypak. Service must be performed by a recognized and certified service agency during normal working hours. All other costs are excluded from this warranty and are the owners responsibility.

ADDITIONAL WARRANTY EXCLUSIONS:

This Warranty does not cover failures or malfunctions resulting from:

1. Failure to properly install, operate or maintain the booster heater in accordance with our printed instructions;
2. Abuse, alteration, accident, fire, flood and the like;
3. Sediment or lime buildup, freezing or other conditions causing inadequate water circulation;
4. High velocity flow exceeding booster heater design rates;
5. Failure of connected systems devices, such as pump or controller;
6. Use of non-factory authorized accessories or other components in conjunction with the booster heaters.
7. Failure to eliminate air from, or replenish water in, the connected water system;
8. Chemical contamination of combustion air or owner's use of chemical additives to water.

TO MAKE A WARRANTY CLAIM:

Promptly notify the selling dealer, supplying model and serial numbers and description of the problem. The dealer must then notify it's Raypak distributor for instructions regarding the claim. If the dealer is not available, contact SERVICE MANAGER, at the address listed below. In all cases, proper authorization must first be received from Raypak before any part is replaced. Any replaced part must be made available to Raypak in exchange for replacement.

EXCLUSIVE WARRANTY - LIMITATION OF LIABILITY:

This is the only warranty given by Raypak. No one is authorized to make any other warranties on Raypak's behalf. ALL OTHER WARRANTIES, EXPRESS OR IMPLIED, INCLUDING BUT NOT LIMITED TO THE IMPLIED WARRANTIES OF MERCHANTABILITY AND FITNESS FOR A PARTICULAR PURPOSE, ARE EXCLUDED. Some States do not allow limitations on how long an implied warranty lasts, or for the exclusion or incidental or consequential damages, so the above limitation or exclusion may not apply to you.

THIS LIMITED WARRANTY GIVES YOU SPECIFIC LEGAL RIGHTS. YOU MAY ALSO HAVE OTHER RIGHTS WHICH VARY FROM STATE TO STATE.

The sole remedy against Raypak with respect to defective parts shall be as provided in this Warranty. It is agreed that Raypak shall have no liability, whether under this Warranty, or in contract, tort, or otherwise, for any special, consequential, or incidental damages.

RAYPAK, INC., 2151 Eastman Avenue, Oxnard, CA 93030 (805) 278-5300



www.raypak.com

Raypak, Inc., 2151 Eastman Avenue, Westlake Village, CA 93030 (805) 278-5300 FAX (800) 872-9725
Raypak Canada Limited, 2805 Slough St., Mississauga, Ontario, Canada L4T 1G2 (416) 677-7999 FAX (416) 677-8036

Litho in U.S.A.