

OPERATOR'S MANUAL

LP2003-X

INCLUDING: SPECIFICATIONS, SERVICE KITS, PLACING INTO SERVICE, TROUBLESHOOTING
 INCLUDE MANUAL: LM2260E-X (97999-693), S-633 GENERAL INFORMATION (97999-625)

RELEASED: 11-1-96
 REVISED: 4-21-98
 (REV.B)



LP2003-1, LP2004-X, LP2006-1 GREASE PUMP SYSTEMS

SPECIFICATIONS

Model Series	LP2003-1, LP2004-X, LP2006-1
Type	Air Operated, 120 lb. Grease Pump System
Ratio	60:1
Air Motor Diameter	2" (5.08 cm)
Stroke (Single acting)	3" (7.62 cm)
Air Inlet	1/4" - 18 NPTF(f)
Material Outlet	3/8" - 18 NPTF(f)
Pump Construction	Carbon Steel
Dimensional Data & Weight	See Chart

PERFORMANCE

Air Inlet Pressure Range	0 - 125 PSI (0 - 8.6 bar)
Fluid Pressure Range	0 - 7500 PSI (0 - 517 bar)
Displacement In ³ Per Cycle	0.15
Cycles Per Lb.	120
Maximum Delivery / Min.	2.5 lbs (1.13 kg)
Noise Level @ 100 Psi	80 db(A)

SERVICE KITS

- **637225 Pump Rebuild Kit.** Includes the necessary soft parts for normal service of the entire pump.
- Use only genuine ARO® replacement parts to assure compatible pressure rating and longest service life.

GENERAL DESCRIPTION

LP2003-1 Grease Supply Package: This is to be used in conjunction with other components (not supplied) in a new or existing portable or stationary pumping system.

LP2004-1, LP2006-1 Portable Lubrication Systems: Include the 60:1 pump, follower plate and drum cover plus hose and gun. LP2006-1: Also includes dolly.

LP2004-2: Includes 60:1 pump, gun and hose only.

PUMP DATA

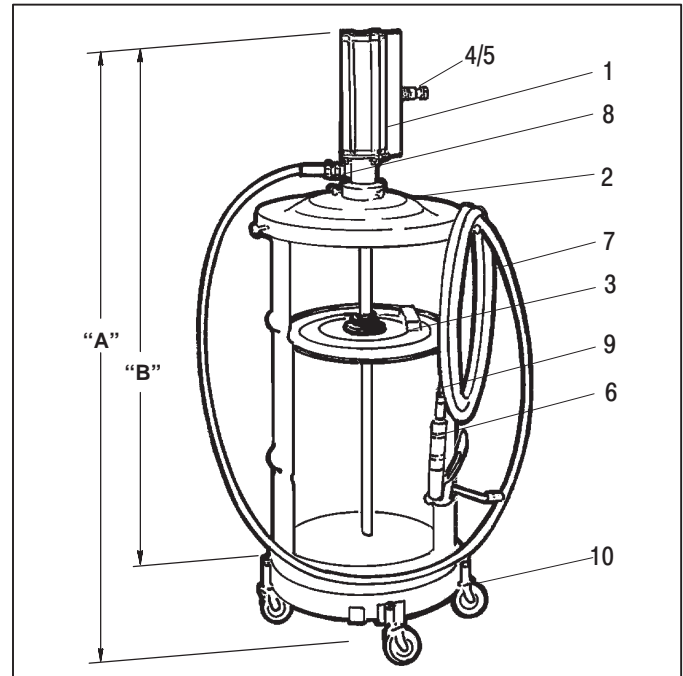

MODEL	"A" (mm)	"B" (mm)	WEIGHT (kg)
LP2003-1		37-1/2 (953)	21.4 (9.7)
LP2004-1,-2		37-1/2 (953)	27.3 (12.3)
LP2006-1	43 (1092)		33.9 (861)

IMPORTANT

This is one of three documents which support the pump system. Replacement copies of these forms are available upon request.

- LP2003-X MODEL OPERATOR'S MANUAL
- LM2260E-X MODEL OPERATOR'S MANUAL
- S-633 GENERAL INFORMATION LUBRICATION SYSTEMS

MAJOR COMPONENT LIST

Item	Description (Size in Inches)	(Qty)	Part No.
1	Basic 60:1 Grease Pump	(1)	LM2260E-31
2	Cover & Hardware	(1)	94421
3	Follower Plate	(1)	640162
4	Coupler	(1)	210
5	Connector	(1)	2608
6	Grease Gun	(1)	636111
7	10 Foot Material Hose	(1)	624201-10
8	Adapter (1/8 x 3/8)	(1)	76493
9	Z-Swivel	(1)	636077

Item	Description (Size in Inches)	(Qty)	Part No.
10	Dolly Assembly	(1)	640058-2

MODEL	Includes items	MODEL	Includes items
LP2003-1	1 thru 5	LP2004-2	1, 4 thru 9
LP2004-1	1 thru 9	LP2006-1	1 thru 10



INGERSOLL-RAND COMPANY
 ONE ARO CENTER • BRYAN, OHIO 43506-0151
 ☎ (419) 636-4242 • FAX (419) 633-1674 ©1998 • PRINTED IN U.S.A.

INGERSOLL-RAND
FLUID PRODUCTS

PLACING INTO SERVICE

OPERATING AND SAFETY PRECAUTIONS

⚠️WARNING READ THE GENERAL INFORMATION MANUAL INCLUDED FOR OPERATING AND SAFETY PRECAUTIONS AND OTHER IMPORTANT INFORMATION.

⚠️WARNING EXCESSIVE INLET PRESSURE. Can cause explosion resulting in severe injury or death. Do not exceed maximum operating pressure of 7500 psi (517 bar) at 125 psi (8.6 bar) inlet air pressure. Do not run pump without using a regulator to limit air supply pressure to the pump.

**PUMP RATIO X
INLET PRESSURE TO PUMP MOTOR = MAXIMUM PUMP
FLUID PRESSURE**

Pump ratio is an expression of the relationship between the pump motor area and the lower pump end area. EXAMPLE: When 125 p.s.i. (8.6 bar) inlet pressure is supplied to the motor of a 60:1 ratio pump it will develop a maximum of 7500 p.s.i. (517 bar) fluid pressure (at no flow) – as the fluid control is opened, the flow rate will increase as the motor cycle rate increases to keep up with the demand.

⚠️WARNING EXCESSIVE MATERIAL PRESSURE. Can cause equipment failure resulting in severe injury or property damage. Do not exceed the maximum material pressure handling capability of any component in the system. Thermal expansion hazard. This can occur when the fluid in the material line is exposed to elevated temperatures. Example: Material line located in a non-insulated roof area can warm due to sunlight. Install a pressure relief valve in the pumping system if this condition could exist.

AIR AND LUBRICATION REQUIREMENTS

Filtered air will help extend the life of the pump, allowing the pump to operate more efficiently and yield longer service life to moving parts and mechanisms.

- Use an air line filter to provide good quality clean and dry air, install it up stream from the air regulator.
- Use an air regulator on the air supply to control the pump cycle rate, install the regulator as close as possible to the pump.
- In most installations lubrication is not required. If the pump needs to have lubrication, install an air line lubricator between the pump and the air regulator and supply it with a good grade of non-detergent oil or other lubricant compatible with Buna“N” seals. Set at a rate not to exceed one drop per minute.

INSTALLATION

Assemble components included in the package as shown in the Fig.1. NOTE: In rigid plumbing applications, use flexible material and air supply hoses when attaching the pump to prevent damage by vibration.

1. Thread the pump bung adapter into the pump cover, insert the pump into the bung and then secure with the thumb screws provided.
2. Install the outlet adapter, material hose, swivel and gun.
3. Lay the follower on top of a full bucket of grease, feed the lower pump end into the follower and secure the cover with the thumb screws.
4. Attach the coupler to the air supply hose.
5. Connect the material hose to the pump outlet. Tighten all fittings. Use caution not to damage threads.

OPERATION

START-UP

1. Turn the air regulator to “0” pressure setting. Connect the air hose.
2. Prime the pump by cycling slowly, raising the pressure to 20–30 psi. Cycle the pump until the test grease and any trapped air has been purged from the system.
3. Close the dispensing device. Allow the pump to build line pressure and stall. Check for any leaks and re-torque fittings if needed. Adjust air pressure upward as required for the application.

NOTICE: If the pump does not prime soon after initial start-up, establish what the problem is to prevent unnecessary damage to the pump plunger.

SHUTDOWN

- Disconnect the air supply from the pump if it is to be inactive for a few hours. Open the dispensing device to relieve line pressure.

SERVICE

Refer to the basic pump manual for service instructions which also covers disassembly and reassembly for installation of the rebuild kit.

TROUBLE SHOOTING

If the pump does not cycle or will not deliver material.

- Be certain to check for non-pump problems including kinked, restrictive or plugged inlet/outlet hose or dispensing device. Depressurize the pump system and clean out any obstructions in the inlet/outlet material lines.
- Check all seals, including track gaskets.