



## INSTALLATION INSTRUCTIONS FOR PART 99-8206

### APPLICATIONS

**Toyota Highlander 2001-2007**  
**4-Runner (Excluding Limited) 2003-2008**

# 99-8206



#### KIT FEATURES

- DIN Head Unit Provision with Pocket
- ISO DIN Head Unit Provision with Pocket

#### KIT COMPONENTS

A) Radio Housing • B) ISO Brackets • C) ISO Trim Plate • D) Highlander Brackets • E) 4-Runner Brackets

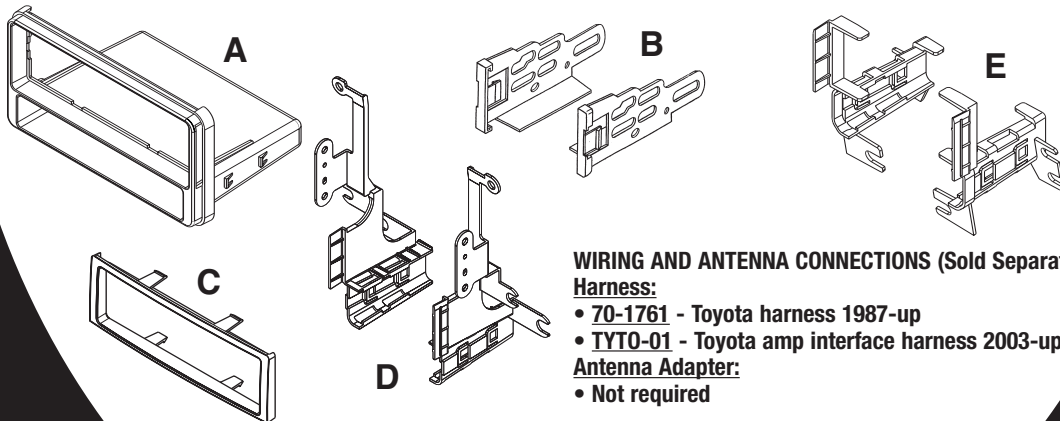

#### TOOLS REQUIRED:

Phillips Screwdriver • Socket Wrench • Cutting Tool



1-800-221-0932



www.metraonline.com

© COPYRIGHT 2004-2009 METRA ELECTRONICS CORPORATION

# **TABLE OF CONTENTS**

## **Dash Disassembly**

<b>- 2003-2008 Toyota 4 Runner (Excluding Limited) .....</b>	<b>1</b>
<b>- 2001-2007 Toyota Highlander .....</b>	<b>2</b>

## **Kit Assembly**

<b>- 4 Runner Bracket Assembly .....</b>	<b>3</b>
<b>- Toyota Highlander Bracket Assembly .....</b>	<b>3</b>
<b>- DIN Head Unit Provision .....</b>	<b>4</b>
<b>- ISO DIN Head Unit Provision .....</b>	<b>5</b>

<b><u>Final Assembly</u> .....</b>	<b>6</b>
------------------------------------	----------



## **KNOWLEDGE IS POWER**

Enhance your installation and fabrication skills by enrolling in the most recognized and respected mobile electronics school in our industry. Log onto [www.installerinstitute.com](http://www.installerinstitute.com) or call 800-354-6782 for more information and take steps toward a better tomorrow.

## TOYOTA 4 RUNNER 2003-2008 (EXCLUDING LIMITED)

- 1** Disconnect the negative battery terminal to prevent an accidental short circuit.
- 2** Unsnap and remove trim from around shifter.
- 3** Unsnap and remove trim covers from around center console pocket edge at front and rear of console.
- 4** Unsnap and remove center console cover. (Figure A)
- 5** Unsnap trim ring from around ignition key cylinder.
- 6** Remove (1) 10 mm bolt from bottom right of panel below steering column. Unsnap panel and pull away to gain access behind panel. (Figure B)
- 7** Remove (1) 10 mm bolt on bottom left of center panel behind panel below steering column. (Figure B)
- 8** Remove (1) 10 mm bolt beneath climate control behind pocket door. Unsnap and remove climate control. (Figure C)
- 9** Remove (2) 10 mm bolts beneath radio behind climate controls.
- 10** Unsnap and remove entire center panel around radio. (Figure D)
- 11** Remove (2) 10 mm bolts securing radio to remove.

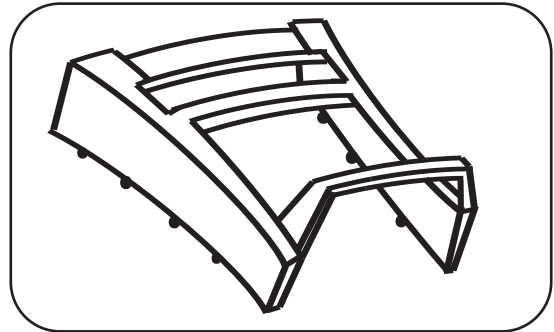
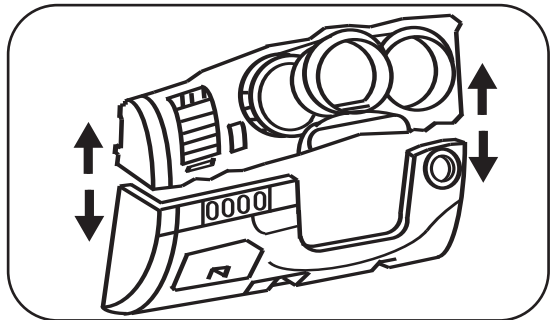
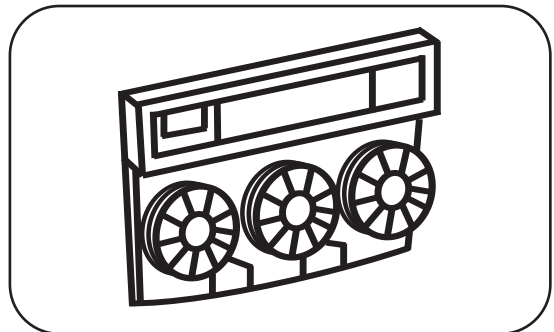
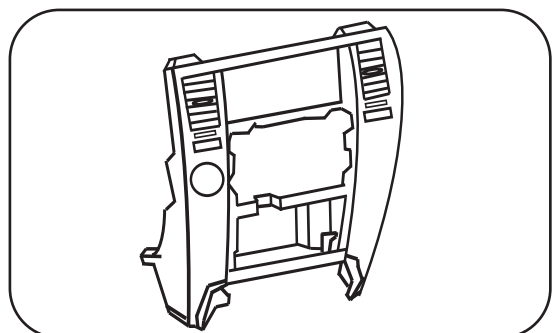
**A**

**B**

**C**

**D**

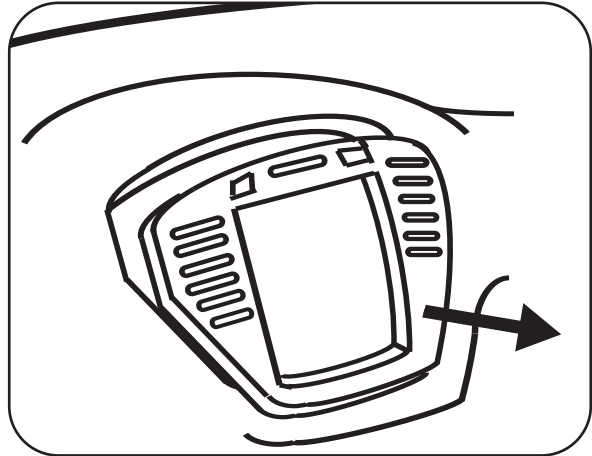
## TOYOTA HIGHLANDER 2001-2007

- 1** Disconnect the negative battery terminal to prevent an accidental short circuit.
- 2** Pull and remove dash panel from radio and climate controls. Tip: There are 8 clips. (Figure A)
- 3** Remove (6) 10mm bolts from radio and climate controls assembly. (Figure B)
- 4** Remove assembly and disconnect the wiring.
- 5** Remove (8) Phillips bolts and (4) Phillips screws to separate brackets from assembly. (Figure C)

**A**



**B**

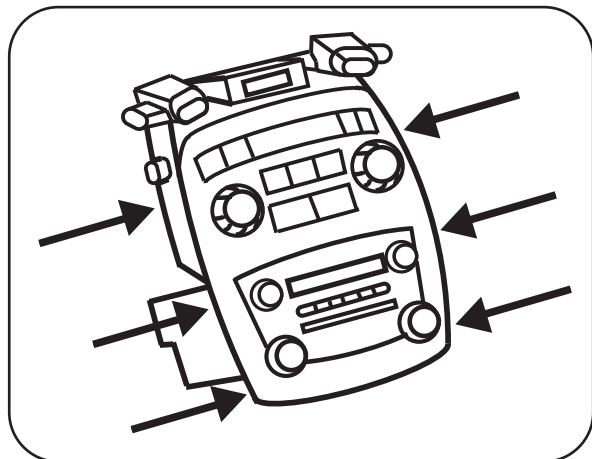

**C**

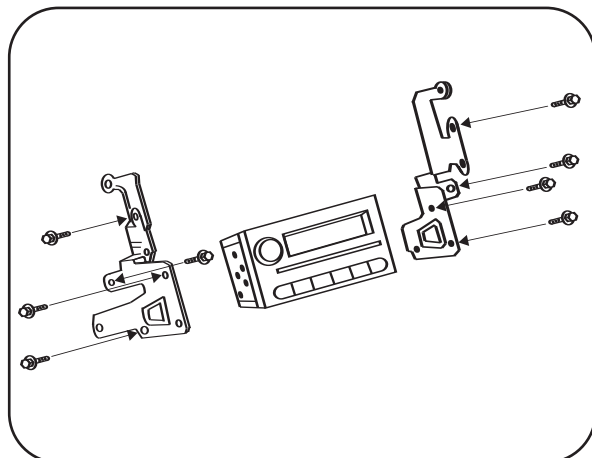

**4 RUNNER BRACKET ASSEMBLY****TOYOTA HIGHLANDER BRACKET ASSEMBLY**

- 1 Snap the appropriately marked Mounting Brackets for your application onto the sides of the Radio Housing. The brackets are marked 4-Runner or Highlander and left or right. **(Figure A - 4 RUNNER)**  
**(Figure B - HIGHLANDER)**

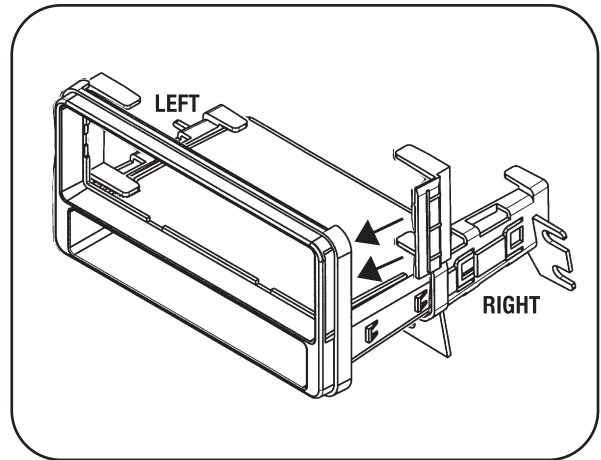
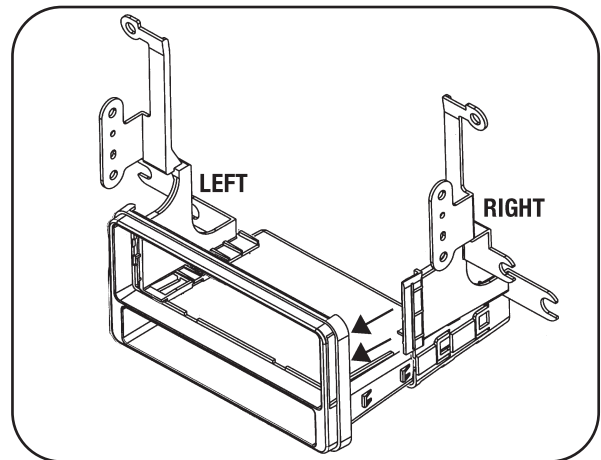
**A****B**

## DIN HEAD UNIT PROVISION WITH POCKET

- 1 Slide the DIN cage into the Radio Housing and secure by bending the metal locking tabs outward. (Figure A)
- 2 Snap the aftermarket radio into the cage and secure. (Figure B)

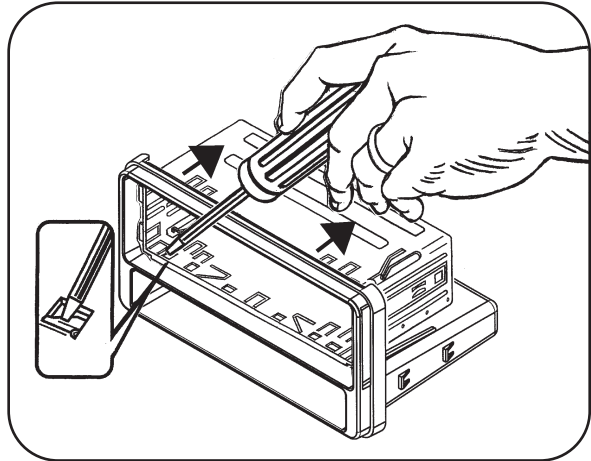
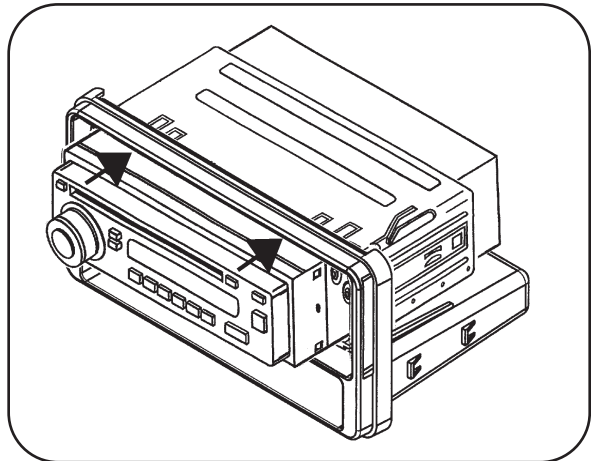
**A****B**

## ISO DIN HEAD UNIT PROVISION

- 1** Mount the ISO Brackets to the head unit with the screws supplied with the radio. (Figure A)
- 2** Snap the radio into the radio housing until the side clips engage. (Figure B)
- 3** Snap the ISO Trim Plate onto the Radio/Housing assembly. (Figure B)

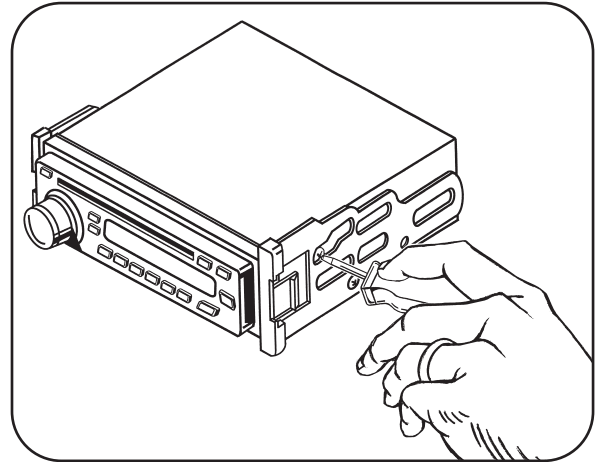
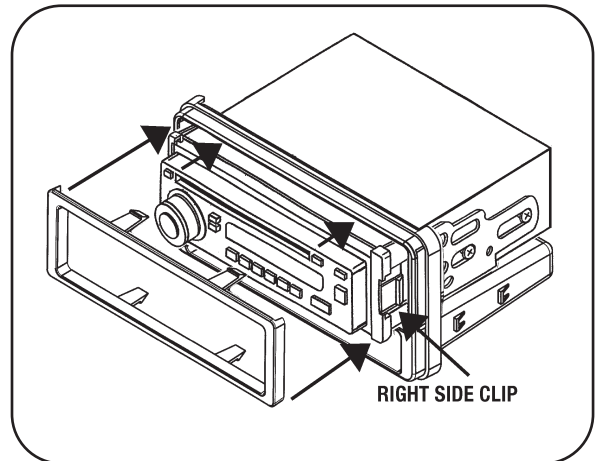
**A**

**B**

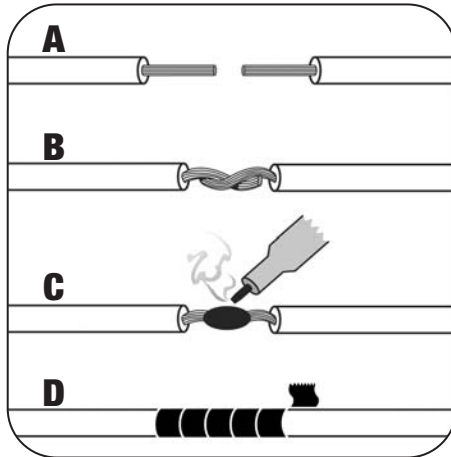
# FINAL ASSEMBLY



- A) Strip wire ends back 1/2"**
- B) Twist ends together**
- C) Solder**
- D) Tape**

- 1** Locate the factory wiring harness in the dash. Metra recommends using the proper mating adapter and making connections as shown. (Isolate and individually tape off the ends of any unused wires to prevent electrical short circuit.)
- 2** Re-connect the negative battery terminal and test the unit for proper operation.
- 3** Reassemble radio and dash assemblies in reverse order of disassembly.

## FINAL WIRING CONNECTIONS

Make wiring connections using the EIA color code chart shown below and the instructions included with the head unit. Metra recommends making connections as shown below; Strip, Splice, Solder, Tape. Isolate and individually tape off ends of any unused wires to prevent electrical short circuit.

## METRA / EIA WIRING CODE

12V Ignition / Acc . . . Red	Dimmer . . . . . Orange / White
12V Batt / Memory . . Yellow	Right Front (+) . . . . White
Ground . . . . . Black*	Left Front (-). . . . . White / Black
Power Antenna . . . . . Blue	Right Rear (+). . . . . Violet
Amp Turn-On . . . . . Blue / White	Right Rear (-) . . . . . Violet / Black
Amp Ground . . . . . Black / White	Left Rear (+). . . . . Green
Illumination. . . . . Orange	

**\*NOTE:** When Black a wire is not present, ground radio to vehicle chassis.  
All colors may not be present on all leads due to manufacturer's specifications.

**1-800-221-0932****www.metraonline.com**