



REL2064

Relay Interface Unit



C1518M-A (11/02)

CONTENTS

Section	Page
IMPORTANT SAFEGUARDS AND WARNINGS	3
OVERVIEW	4
DESCRIPTION	4
FRONT VIEW	4
REAR VIEW	5
INSTALLATION	6
MOUNTING	6
WIRING RELAYS	6
CONNECTING TO THE CM6800	9
SETTING THE DIP SWITCHES	10
OPERATION	12
MEMORY FEATURE	12
OPERATING RELAYS FROM THE KBD960	13
ACTIVATING RELAYS USING F12	13
ACTIVATING RELAYS FROM THE GPI MENU	13
MOMENTARY	13
LATCHING	13
TROUBLESHOOTING	15
APPENDIX A	16
SPECIFICATIONS	18
REGULATORY NOTICES	19
WARRANTY AND RETURN INFORMATION	19

LIST OF ILLUSTRATIONS

Figure	Page
1 Front View with Panel Removal	4
2 Rear View of the REL2064	5
3 Rack-Mount Installation	6
4 Relay Interface Contact Configuration	7
5 Wiring Relays to Peripheral Equipment	8
6 Connection to the CM6800	9
7 SW1 DIP Switches	11
8 SW2 DIP Switches	11
9 SW3 DIP Switches	11
10 Power Input Fuse Replacement	15
11 REL2064 Dimension Diagram	18

LIST OF TABLES

Table	Page
A Switch 1	10
B Switch 2	10
C Switch 3	10
D Relay Unit 1	14
E Relay Unit 2	14

IMPORTANT SAFEGUARDS AND WARNINGS

1. Read, keep, and follow these instructions.
2. Heed all warnings.
3. There are no user-serviceable parts inside this unit. Only authorized service personnel may open the unit.
4. Installation and servicing should only be done by qualified service personnel and conform to all local codes.
5. **WARNING:** To reduce the risk of fire or electric shock, do not expose this unit to rain or moisture if this unit is designed for indoor use only.
6. Unless this unit is specifically marked as a NEMA Type 3, 3R, 3S, 4, 4X, 6 or 6P enclosure, it is designed for indoor use only and it must not be installed where exposed to rain or moisture.
7. Do not expose this unit to dripping or splashing. Do not place objects filled with liquids, such as vases, on this unit.
8. Do not block any ventilation openings. Install in accordance with the manufacturer's instructions.
9. The installation method and materials should be capable of supporting four times the weight of the unit and equipment.
10. Do not install near any heat source.
11. Only use attachments/accessories specified by the manufacturer.
12. Clean only with dry cloth.
13. Do not defeat the safety purpose of the polarized or grounding-type plug.
14. Protect the power cord from being walked on or pinched, particularly at plugs, convenience receptacles, and the point where they exit from the unit.
15. Unplug this unit during lightning storms or when unused for long periods of time.

The product and/or manual may bear the following marks:



This symbol indicates that dangerous voltage constituting a risk of electric shock is present within this unit.



This symbol indicates that there are important operating and maintenance instructions in the literature accompanying this unit.



Please thoroughly familiarize yourself with the information in this manual prior to installation and operation.

FOR QUALIFIED SERVICE PERSONNEL ONLY

1. Only use replacement parts recommended by Pelco.
2. After replacement/repair of this unit's electrical components, conduct a resistance measurement between line and exposed parts to verify the exposed parts have not been connected to line circuitry.

OVERVIEW

DESCRIPTION

The REL2064 Relay Interface Unit provides up to 64 single-pole, single-throw (SPST) dry contact outputs for direct or automatic control of peripheral equipment. Using Pelco's proprietary M protocol, the relay unit communicates with Pelco's CM6800 matrix switcher via an RS-485 communication interface. The relay unit can be located remotely from the system controller and still communicate back to the central system when an alarm occurs.

Other features include the following:

- Multiple units can be cascaded to provide multiple relay contact points on a single M port connection.
- Relay output contacts can be configured for normally open (N.O.) or normally closed (N.C.) operation.
- With the memory feature, relay groups can retain their contact position in the event of a power failure or front panel reset.
- The unit is powered by an auto-ranging power supply.
- The unit occupies one rack unit (1.75 inches or 4.45 cm), accommodating multiple types of mounting.

FRONT VIEW

The left side of the front panel includes the green power LED light. This light comes on at power-up.

The right side of the front panel includes the red data LED light. This light continually flashes on and off at a regular rate (about one-second intervals) until the unit is online and communicating with the CM6800. Once online, the LED remains ON. If for any reason communication is lost, the LED flashes again until communication is re-established.

When you remove the front panel, you have access to a reset button and configuration DIP switches.

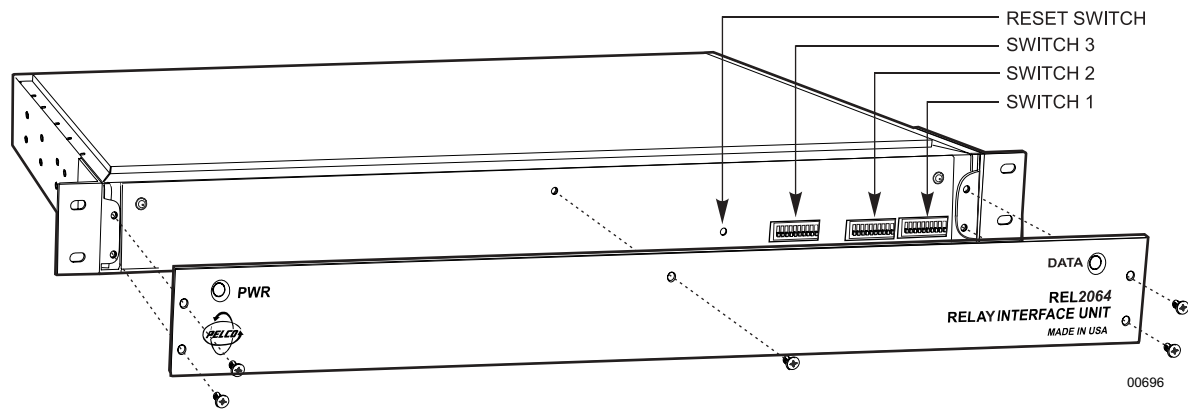

Figure 1. Front View with Panel Removal

REAR VIEW

The rear of the REL2064 unit consists of the following:

1. Four groups of 16 contact pairs, each with mating plugs for the attachment of peripheral equipment; only the group for the first 16 contact pairs is shown in Figure 2 with mating plugs
2. One RS-485 output communication port (RJ-45 type connector)
3. One RS-485 input communication port (RJ-45 type connector)
4. One RS-232 diagnostic communication port (DB9 type connector)
5. The grouped input power functions consisting of input power terminals, a fuse, and an on/off switch

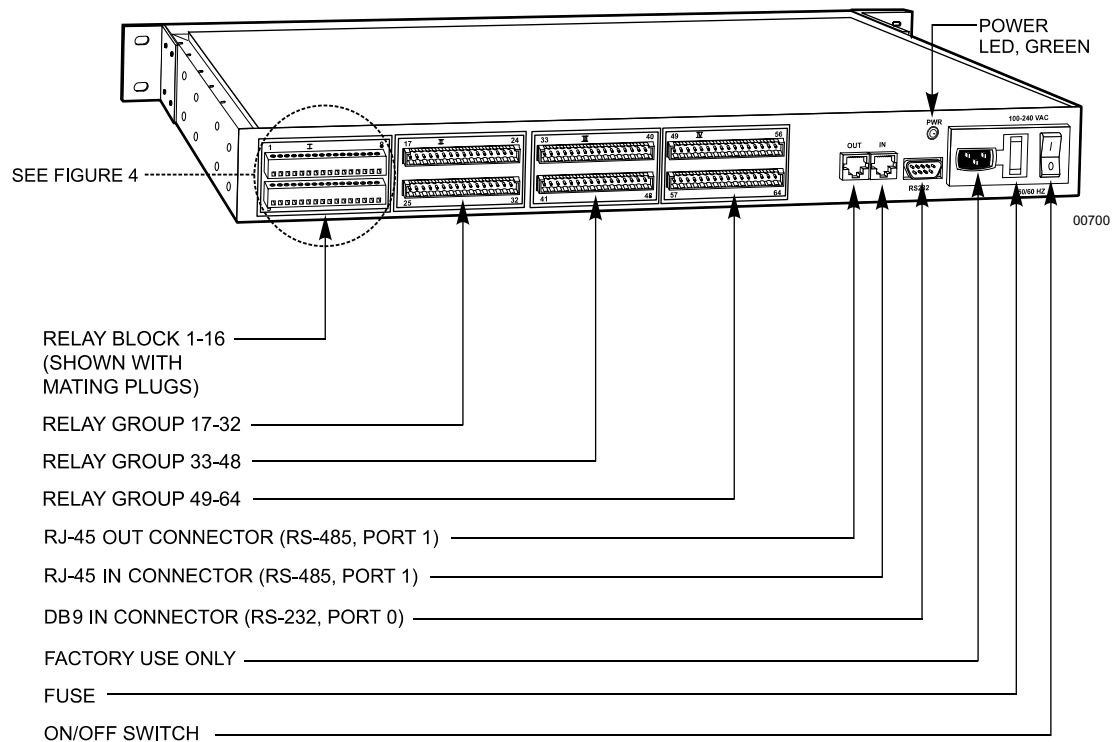

Figure 2. Rear View of the REL2064

INSTALLATION

The following items are supplied:

- REL2064 Relay Interface Unit
- 120 VAC power cord
- 220 VAC power cord
- Pelco screwdriver
- 10-foot (3 m) straight RJ-45 cable (8-conductor)
- 4 #10 screws with nylon washers

MOUNTING

Install the relay unit in a 19-inch rack. The unit occupies one rack unit (1.75 inches or 4.45 cm) of space. You can mount the relay unit to something other than a standard 19-inch rack by relocating the rack ears to another location.

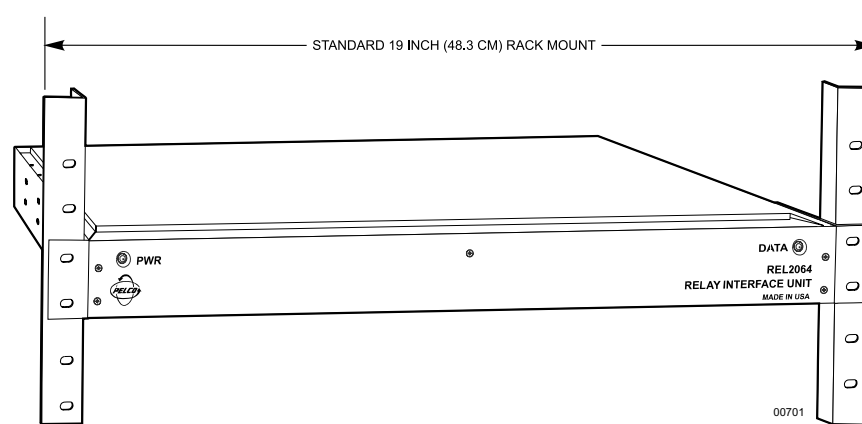

Figure 3. Rack-Mount Installation

WIRING RELAYS

The relay unit has four groups of relay contacts. Each group represents 16 pairs of relay contacts:

- Group I – 1-8, 9-16
- Group II – 17-24, 25-32
- Group III – 33-40, 41-48
- Group IV – 49-56, 57-64

Each of the four groups contains two connectors with input mating plugs. The top connector is for the first eight pairs of relay contacts and the bottom connector is for the last eight pairs of relay contacts. Each mating plug has 16 screw terminals and 16 pins. When you place a wire into a pin, tighten the screw to secure it.

Refer to Figure 4 to determine the screw terminal number for a particular contact. The numbers that appear on the mating plugs in Figure 4 are for illustration only. The terminal positions on the actual physical plugs are not numbered.

Refer to Figure 5 for wiring the relays to peripheral equipment.

BLOCK 1 RELAY CONTACTS (1 - 16)
SHOWN WITH REMOVABLE MATING PLUGS

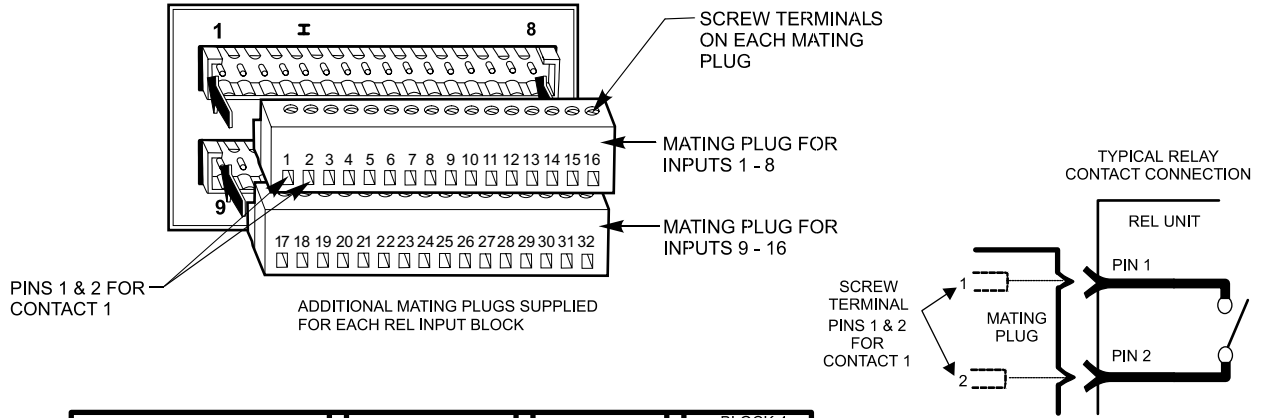

MATING PLUG PIN #	BLOCK 1 RELAY CONTACT	BLOCK 2 RELAY CONTACT	BLOCK 3 RELAY CONTACT	BLOCK 4 RELAY CONTACT
1	1	17	33	49
2	1	17	33	49
3	2	18	34	50
4	2	18	34	50
5	3	19	35	51
6	3	19	35	51
7	4	20	36	52
8	4	20	36	52
9	5	21	37	53
10	5	21	37	53
11	6	22	38	54
12	6	22	38	54
13	7	23	39	55
14	7	23	39	55
15	8	24	40	56
16	8	24	40	56
17	9	25	41	57
18	9	25	41	57
19	10	26	42	58
20	10	26	42	58
21	11	27	43	59
22	11	27	43	59
23	12	28	44	60
24	12	28	44	60
25	13	29	45	61
26	13	29	45	61
27	14	30	46	62
28	14	30	46	62
29	15	31	47	63
30	15	31	47	63
31	16	32	48	64
32	16	32	48	64

00702

Figure 4. Relay Interface Contact Configuration

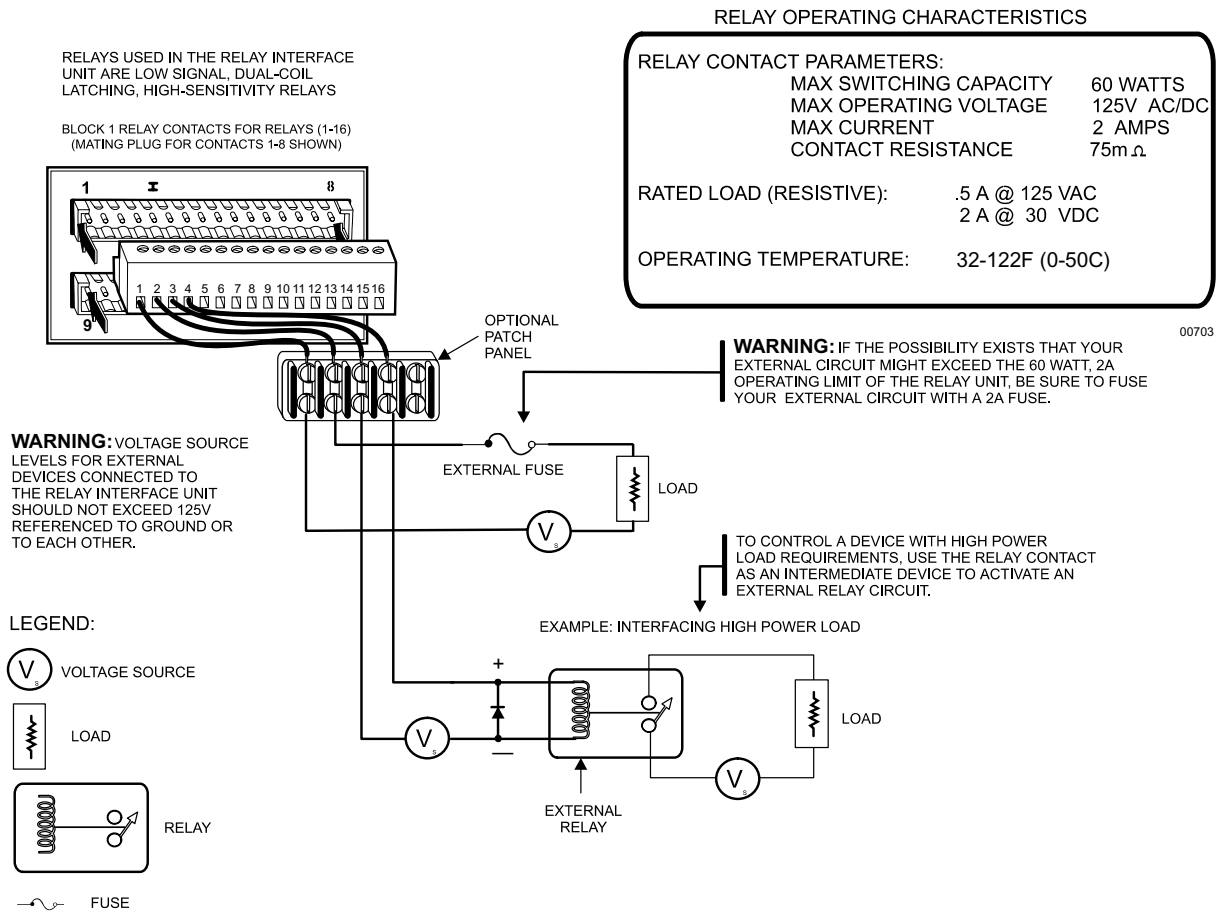

Figure 5. Wiring Relays to Peripheral Equipment

CONNECTING TO THE CM6800

Connect the supplied RJ-45 straight cable from the REL2064 OUT port to the CM6800 COM 3 port. The active pin-outs are associated with the four outer pins: 1, 2, 7, and 8. Refer to Figure 6.

If you want to place the relay unit some distance from the CM6800, the RS-485 communication from the relay unit to the controller should not exceed 4,000 feet (1,219 m). You need an RJ-45 wall-block terminal (part number CON12J008Z03G0Z) if operating from a remote site.

To cascade two relay units, connect a straight cable from the OUT port of the second relay unit to the IN port of the first relay unit. The first unit is the one you connect to the CM6800.

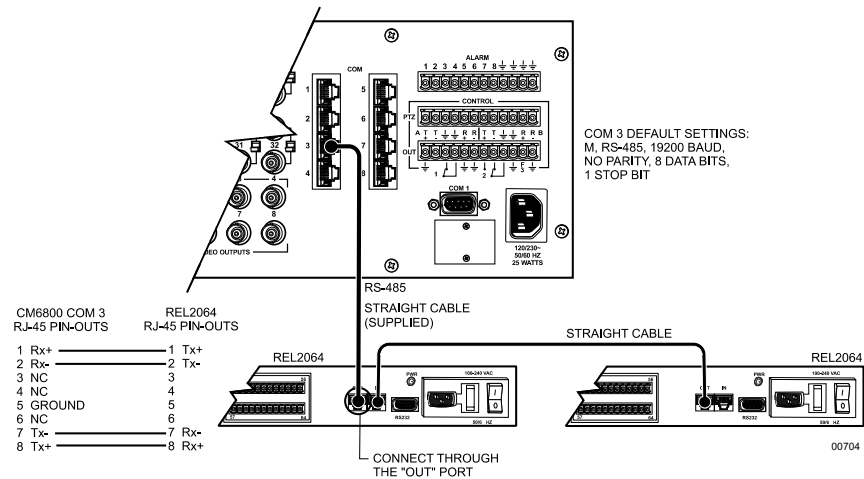

Figure 6. Connection to the CM6800

SETTING THE DIP SWITCHES

The positioning of the DIP switches on the front of the relay unit determines how the relay unit operates. You must recycle power whenever you make changes to the DIP switches.

1. Remove the front panel by unscrewing the five flat-head Phillips screws. You see three switches.

Table A. Switch 1

SW1 – Communications/Relay Type Selection													
Baud				Relay Range				GPI	Contacts	1-16	17-32	33-48	49-64
1200	Off	Off	Off	1-64	Off	Off	Off	1	Norm Open (N.O.)	Off	Off	Off	Off
2400	On	Off	Off	65-128	On	Off	Off	9					
4800	Off	On	Off	129-192	Off	On	Off	17					
9600	On	On	Off	193-256	On	On	Off	25					
19200	Off	Off	On	257-320	Off	Off	On	33	Norm Closed (N.C.)	On	On	On	On
38400	On	Off	On	321-384	On	Off	On	41					
57600	Off	On	On	385-448	Off	On	On	49					
115200	On	On	On	449	On	On	On	57					
DIP Switch	1	2	3		4	5	6			7	8	9	10

Table B. Switch 2

Address	SW2 – Address										
1	Off	Off	Off	Off	Off	Off	Off	Off	Off	Off	Off
2	On	Off	Off	Off	Off	Off	Off	Off	Off	Off	Off
3	Off	On	Off	Off	Off	Off	Off	Off	Off	Off	Off
4	On	On	Off	Off	Off	Off	Off	Off	Off	Off	Off
5	Off	Off	On	Off	Off	Off	Off	Off	Off	Off	Off
6	On	Off	On	Off	Off	Off	Off	Off	Off	Off	Off
7	Off	On	On	Off	Off	Off	Off	Off	Off	Off	Off
8	On	On	On	Off	Off	Off	Off	Off	Off	Off	Off
9	Off	Off	Off	On	Off	Off	Off	Off	Off	Off	Off
10	On	Off	Off	On	Off	Off	Off	Off	Off	Off	Off
11	Off	On	Off	On	Off	Off	Off	Off	Off	Off	Off
12	On	On	Off	On	Off	Off	Off	Off	Off	Off	Off
13	Off	Off	On	On	Off	Off	Off	Off	Off	Off	Off
14	On	Off	On	On	Off	Off	Off	Off	Off	Off	Off
15	Off	On	On	On	Off	Off	Off	Off	Off	Off	Off
16	On	On	On	On	Off	Off	Off	Off	Off	Off	Off
DIP Switch	1	2	3	4	5	6	7	8	9	10	

Table C. Switch 3

SW3 – Power-On Initialization							
	N/A	Initialization State	Relay 1-16	Relay 17-32	Relay 33-48	Relay 49-64	
	Off	Initialize	Off	Off	Off	Off	Off
		Maintain Last State	On	On	On	On	
DIP Switch	1, 2		3	4	5	6	7-10

2. Set the DIP switches.

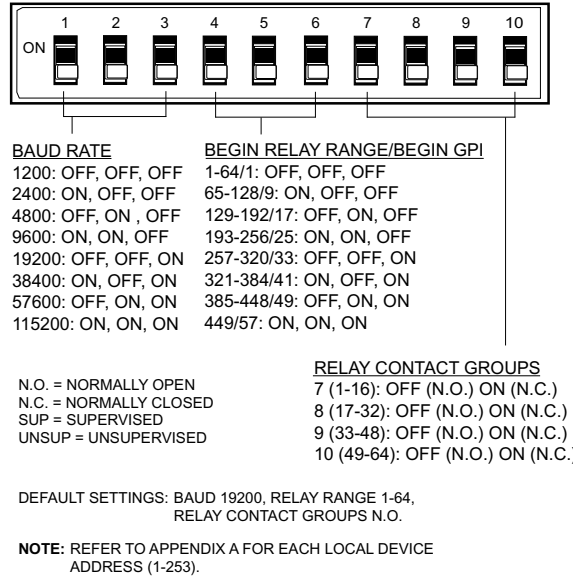

Figure 7. SW1 DIP Switches

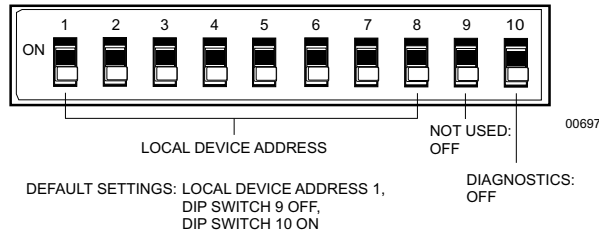

Figure 8. SW2 DIP Switches

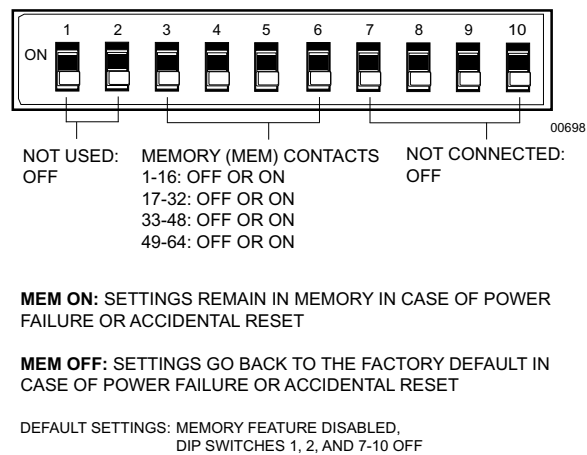

Figure 9. SW3 DIP Switches

3. Replace the front panel.

OPERATION

The function of the relay unit is to operate relays to control peripheral equipment. Each relay unit processes and executes only commands with addresses that match those of the relay units.

When power is turned on, the green power LEDs on the front and back of the unit light. The red data LED light on the front continually flashes on and off at a regular rate (about one-second intervals) until the unit is online and communicating with the CM6800. Once online, the LED remains ON. If for any reason communication is lost, the LED flashes again until communication is re-established.

MEMORY FEATURE

Although relay groups retain their contact position in the event of a power failure, the unit does not report relay status when requested after power is recycled. Since the firmware has no battery backed up memory, it does not know the state of the relays and may report them incorrectly. If a KBD960 keyboard is present on the system, it can contain inaccurate information in the GPI menu.

If the memory feature is disabled, the relays are all placed in a known state at startup. Under these conditions, the state of the relays are all known and are reported when requested. True relay status shows up on the keyboard display.

OPERATING RELAYS FROM THE KBD960

To operate relays from a KBD960 keyboard, you must know which GPI to call, and which auxiliary (AUX) to select on the keyboard.

You can cascade two relay units. Each relay unit has eight GPIs. Relay Unit 1 has a GPI range of 1-8, and Relay Unit 2 has a GPI range of 9-16. Refer to Tables C and D.

There are two ways you can operate relays from the KBD960.

ACTIVATING RELAYS USING F12

NOTE: You hear a brief click from the relay unit whenever you activate a momentary or latching relay contact.

Follow these steps to activate a momentary relay:

1. Go to Main Menu 1.
2. Enter a logical relay contact number (1-128).
3. Press F12.





A momentary relay does not remain on. Only a latched relay remains on. If you want a latched relay, you must activate it from the GPI Menus.

ACTIVATING RELAYS FROM THE GPI MENUS

You can activate relays from the GPI Menus as momentary or latching. A momentary relay goes on briefly and then turns off. A latched relay remains on until you turn it off.

Momentary

To activate relay contact 4, for example, follow these steps:

1. Go to Main Menu 1 and enter 1 (GPI). GPI 1 is associated with relay contact 4. Refer to Table C.
2. Select  to bring up GPI Menu 1. This menu displays auxiliaries 1-4. Make sure  is highlighted. When  is highlighted, any relay you activate becomes momentary.
3. Select .

Latching

To activate the same relay as latching, follow these steps:





1. Go to Main Menu 1 and enter 1 (GPI).
2. Select  to bring up GPI Menu 1.
3. Select  so that it is not highlighted. When  is not highlighted, any relay you activate latches (remains on).
4. Select . This icon becomes highlighted.
5. Select  and then the highlighted auxiliary icon to turn off the latched relay.

Table D. Relay Unit 1

GPI	Relay Contacts							
1	1	2	3	4	5	6	7	8
2	9	10	11	12	13	14	15	16
3	17	18	19	20	21	22	23	24
4	25	26	27	28	29	30	31	32
5	33	34	35	36	37	38	39	40
6	41	42	43	44	45	46	47	48
7	49	50	51	52	53	54	55	56
8	57	58	59	60	61	62	63	64
Associated Aux	1	2	3	4	5	6	7	8

Table E. Relay Unit 2

GPI	Relay Contacts							
9	65	66	67	68	69	70	71	72
10	73	74	75	76	77	78	79	80
11	81	82	83	84	85	86	87	88
12	89	90	91	92	93	94	95	96
13	97	98	99	100	101	102	103	104
14	105	106	107	108	109	110	111	112
15	113	114	115	116	117	118	119	120
16	121	122	123	124	125	126	127	128
Associated Aux	1	2	3	4	5	6	7	8

NOTE: In Relay Unit 2, GPIs 9-16 are associated with the physical relays (1-64) on the back of the unit. However, GPIs 9-16 are also associated with logical relays 65-128. For example, the physical relays for GPI 9 are 1-8 and the logical relays are 65-72.

TROUBLESHOOTING

Problem	Solution
Why were the contact positions lost when there was a power failure?	Make sure DIP switches 3-6 of SW3 are enabled so that your settings remain in memory.
Why is the unit not operating as it should?	Make sure the power cord is plugged in and the power switch is turned on. If the unit still fails to operate, remove the front panel and press the reset button. This initializes the unit to its start-up settings. Make sure the DIP switch settings and software settings are correct. Check the input power fuse. You may need to replace it. Refer to Figure 10.
What is the DB9 port used for?	This port is used for diagnostics. A technical support representative may ask you to enable this feature should a problem arise with the unit. This port is not needed for the everyday operation of the REL2064.

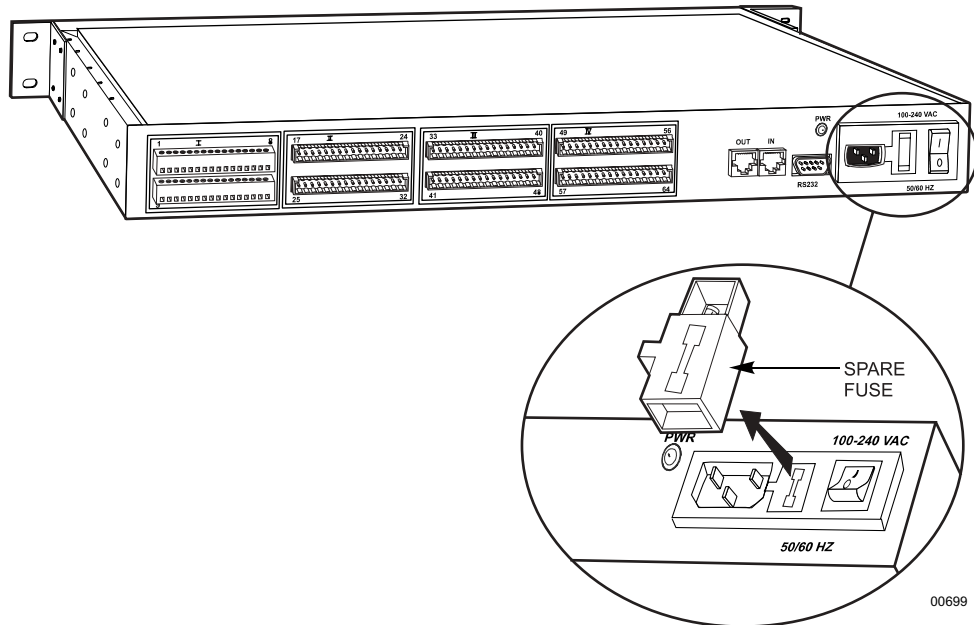

Figure 10. Power Input Fuse Replacement

APPENDIX A

Address	DIP Switch							
	1	2	3	4	5	6	7	8
1	0	0	0	0	0	0	0	0
2	1	0	0	0	0	0	0	0
3	0	1	0	0	0	0	0	0
4	1	1	0	0	0	0	0	0
5	0	0	1	0	0	0	0	0
6	1	0	1	0	0	0	0	0
7	0	1	1	0	0	0	0	0
8	1	1	1	0	0	0	0	0
9	0	0	0	1	0	0	0	0
10	1	0	0	1	0	0	0	0
11	0	1	0	1	0	0	0	0
12	1	1	0	1	0	0	0	0
13	0	0	1	1	0	0	0	0
14	1	0	1	1	0	0	0	0
15	0	1	1	1	0	0	0	0
16	1	1	1	1	0	0	0	0
17	0	0	0	0	1	0	0	0
18	1	0	0	0	1	0	0	0
19	0	1	0	0	1	0	0	0
20	1	1	0	0	1	0	0	0
21	0	0	1	0	1	0	0	0
22	1	0	1	0	1	0	0	0
23	0	1	1	0	1	0	0	0
24	1	1	1	0	1	0	0	0
25	0	0	0	1	1	0	0	0
26	1	0	0	1	1	0	0	0
27	0	1	0	1	1	0	0	0
28	1	1	0	1	1	0	0	0
29	0	0	1	1	1	0	0	0
30	1	0	1	1	1	0	0	0
31	0	1	1	1	1	0	0	0
32	1	1	1	1	1	0	0	0
33	0	0	0	0	0	1	0	0
34	1	0	0	0	0	1	0	0
35	0	1	0	0	0	1	0	0
36	1	1	0	0	0	1	0	0
37	0	0	1	0	0	1	0	0
38	1	0	1	0	0	1	0	0
39	0	1	1	0	0	1	0	0
40	1	1	1	0	0	1	0	0
41	0	0	0	1	0	1	0	0
42	1	0	0	1	0	1	0	0
43	0	1	0	1	0	1	0	0
44	1	1	0	1	0	1	0	0
45	0	0	1	1	0	1	0	0
46	1	0	1	1	0	1	0	0
47	0	1	1	1	0	1	0	0
48	1	1	1	1	0	1	0	0
49	0	0	0	0	0	1	0	0
50	1	0	0	0	1	1	0	0
51	0	1	0	0	1	1	0	0
52	1	1	0	0	1	1	0	0
53	0	0	1	0	1	1	0	0
54	1	0	1	0	1	1	0	0
55	0	1	1	0	1	1	0	0
56	1	1	1	0	1	1	0	0
57	0	0	0	1	1	1	0	0
58	1	0	0	1	1	1	0	0
59	0	1	0	1	1	1	0	0
60	1	1	0	1	1	1	0	0
61	0	0	1	1	1	1	0	0
62	1	0	1	1	1	1	0	0

0 = OFF
1 = ON

Address	DIP Switch							
	1	2	3	4	5	6	7	8
63	0	1	1	1	1	1	0	0
64	1	1	1	1	1	1	0	0
65	0	0	0	0	0	0	1	0
66	1	0	0	0	0	0	1	0
67	0	1	0	0	0	0	1	0
68	1	1	0	0	0	0	1	0
69	0	0	1	0	0	0	1	0
70	1	0	1	0	0	0	1	0
71	0	1	1	0	0	0	1	0
72	1	1	1	0	0	0	1	0
73	0	0	0	1	0	0	1	0
74	1	0	0	1	0	0	1	0
75	0	1	0	1	0	0	1	0
76	1	1	0	1	0	0	1	0
77	0	0	1	1	0	0	1	0
78	1	0	1	1	0	0	1	0
79	0	1	1	1	0	0	1	0
80	1	1	1	1	0	0	1	0
81	0	0	0	0	1	0	1	0
82	1	0	0	0	1	0	1	0
83	0	1	0	0	1	0	1	0
84	1	1	0	0	1	0	1	0
85	0	0	1	0	1	0	1	0
86	1	0	1	0	1	0	1	0
87	0	1	1	0	1	0	1	0
88	1	1	1	0	1	0	1	0
89	0	0	0	1	1	0	1	0
90	1	0	0	1	1	0	1	0
91	0	1	0	1	1	0	1	0
92	1	1	0	1	1	0	1	0
93	0	0	1	1	1	0	1	0
94	1	0	1	1	1	0	1	0
95	0	1	1	1	1	0	1	0
96	1	1	1	1	1	0	1	0
97	0	0	0	0	0	1	1	0
98	1	0	0	0	0	1	1	0
99	0	1	0	0	0	1	1	0
100	1	1	0	0	0	1	1	0
101	0	0	1	0	0	1	1	0
102	1	0	1	0	0	1	1	0
103	0	1	1	0	0	1	1	0
104	1	1	1	0	0	1	1	0
105	0	0	0	1	0	1	1	0
106	1	0	0	1	0	1	1	0
107	0	1	0	1	0	1	1	0
108	1	1	0	1	0	1	1	0
109	0	0	1	1	0	1	1	0
110	1	0	1	1	0	1	1	0
111	0	1	1	1	0	1	1	0
112	1	1	1	1	0	1	1	0
113	0	0	0	0	1	1	1	0
114	1	0	0	0	1	1	1	0
115	0	1	0	0	1	1	1	0
116	1	1	0	0	1	1	1	0
117	0	0	1	0	1	1	1	0
118	1	0	1	0	1	1	1	0
119	0	1	1	0	1	1	1	0
120	1	1	1	0	1	1	1	0
121	0	0	0	1	1	1	1	0
122	1	0	0	1	1	1	1	0
123	0	1	0	1	1	1	1	0
124	1	1	0	1	1	1	1	0

(Continued on next page)

Address	DIP Switch							
	1	2	3	4	5	6	7	8
125	0	0	1	1	1	1	1	0
126	1	0	1	1	1	1	1	0
127	0	1	1	1	1	1	1	0
128	1	1	1	1	1	1	1	0
129	0	0	0	0	0	0	0	1
130	1	0	0	0	0	0	0	1
131	0	1	0	0	0	0	0	1
132	1	1	0	0	0	0	0	1
133	0	0	1	0	0	0	0	1
134	1	0	1	0	0	0	0	1
135	0	1	1	0	0	0	0	1
136	1	1	1	0	0	0	0	1
137	0	0	0	1	0	0	0	1
138	1	0	0	1	0	0	0	1
139	0	1	0	1	0	0	0	1
140	1	1	0	1	0	0	0	1
141	0	0	1	1	0	0	0	1
142	1	0	1	1	0	0	0	1
143	0	1	1	1	0	0	0	1
144	1	1	1	1	0	0	0	1
145	0	0	0	0	1	0	0	1
146	1	0	0	0	1	0	0	1
147	0	1	0	0	1	0	0	1
148	1	1	0	0	1	0	0	1
149	0	0	1	0	1	0	0	1
150	1	0	1	0	1	0	0	1
151	0	1	1	0	1	0	0	1
152	1	1	1	0	1	0	0	1
153	0	0	0	1	1	0	0	1
154	1	0	0	1	1	0	0	1
155	0	1	0	1	1	0	0	1
156	1	1	0	1	1	0	0	1
157	0	0	1	1	1	0	0	1
158	1	0	1	1	1	0	0	1
159	0	1	1	1	1	0	0	1
160	1	1	1	1	1	0	0	1
161	0	0	0	0	0	1	0	1
162	1	0	0	0	0	1	0	1
163	0	1	0	0	0	1	0	1
164	1	1	0	0	0	1	0	1
165	0	0	1	0	0	1	0	1
166	1	0	1	0	0	1	0	1
167	0	1	1	0	0	1	0	1
168	1	1	1	0	0	1	0	1
169	0	0	0	1	0	1	0	1
170	1	0	0	1	0	1	0	1
171	0	1	0	1	0	1	0	1
172	1	1	0	1	0	1	0	1
173	0	0	1	1	0	1	0	1
174	1	0	1	1	0	1	0	1
175	0	1	1	1	0	1	0	1
176	1	1	1	1	0	1	0	1
177	0	0	0	0	1	1	0	1
178	1	0	0	0	1	1	0	1
179	0	1	0	0	1	1	0	1
180	1	1	0	0	1	1	0	1
181	0	0	1	0	1	1	0	1
182	1	0	1	0	1	1	0	1
183	0	1	1	0	1	1	0	1
184	1	1	1	0	1	1	0	1
185	0	0	0	1	1	1	0	1
186	1	0	0	1	1	1	0	1
187	0	1	0	1	1	1	0	1
188	1	1	0	1	1	1	0	1
189	0	0	1	1	1	1	0	1

Address	DIP Switch							
	1	2	3	4	5	6	7	8
190	1	0	1	1	1	1	0	1
191	0	1	1	1	1	1	0	1
192	1	1	1	1	1	1	0	1
193	0	0	0	0	0	0	1	1
194	1	0	0	0	0	0	1	1
195	0	1	0	0	0	0	1	1
196	1	1	0	0	0	0	1	1
197	0	0	1	0	0	0	1	1
198	1	0	1	0	0	0	1	1
199	0	1	1	0	0	0	1	1
200	1	1	1	0	0	0	1	1
201	0	0	0	1	0	0	1	1
202	1	0	0	1	0	0	1	1
203	0	1	0	1	0	0	1	1
204	1	1	0	1	0	0	1	1
205	0	0	1	1	0	0	1	1
206	1	0	1	1	0	0	1	1
207	0	1	1	1	0	0	1	1
208	1	1	1	1	0	0	1	1
209	0	0	0	0	1	0	1	1
210	1	0	0	0	1	0	1	1
211	0	1	0	0	1	0	1	1
212	1	1	0	0	1	0	1	1
213	0	0	1	0	1	0	1	1
214	1	0	1	0	1	0	1	1
215	0	1	1	0	1	0	1	1
216	1	1	1	0	1	0	1	1
217	0	0	0	1	1	0	1	1
218	1	0	0	1	1	0	1	1
219	0	1	0	1	1	0	1	1
220	1	1	0	1	1	0	1	1
221	0	0	1	1	1	0	1	1
222	1	0	1	1	1	0	1	1
223	0	1	1	1	1	0	1	1
224	1	1	1	1	1	0	1	1
225	0	0	0	0	0	1	1	1
226	1	0	0	0	0	1	1	1
227	0	1	0	0	0	1	1	1
228	1	1	0	0	0	1	1	1
229	0	0	1	0	0	1	1	1
230	1	0	1	0	0	1	1	1
231	0	1	1	0	0	1	1	1
232	1	1	1	0	0	1	1	1
233	0	0	0	1	0	1	1	1
234	1	0	0	1	0	1	1	1
235	0	1	0	1	0	1	1	1
236	1	1	0	1	0	1	1	1
237	0	0	1	1	0	1	1	1
238	1	0	1	1	0	1	1	1
239	0	1	1	1	0	1	1	1
240	1	1	1	1	0	1	1	1
241	0	0	0	0	1	1	1	1
242	1	0	0	0	1	1	1	1
243	0	1	0	0	1	1	1	1
244	1	1	0	0	1	1	1	1
245	0	0	1	0	1	1	1	1
246	1	0	1	0	1	1	1	1
247	0	1	1	0	1	1	1	1
248	1	1	1	0	1	1	1	1
249	0	0	0	1	1	1	1	1
250	1	0	0	1	1	1	1	1
251	0	1	0	1	1	1	1	1
252	1	1	0	1	1	1	1	1
253	0	0	1	1	1	1	1	1

0 = OFF
1 = ON

SPECIFICATIONS

ELECTRICAL

Input Voltage:	100-240 VAC, 50/60 Hz, auto-ranging
Power:	30 VA
Data Ports	
Diagnostic:	RS-232, DB9 connector
Input:	RS-485, RJ-45 connector
Output:	RS-485, RJ-45 connector
Indicators:	Two green power LEDs One data LED
Fusing:	500 mA, 250V
Relay Contacts	
Type:	Normally open
Max. Switching Capacity:	60 watts
Max. Operating Voltage:	125 VAC/VDC
Maximum Current:	2 amps
Contact Resistance:	75 milliohms
Rated Load Parameters:	.5A @ 125 VAC; 2A @ 30 VDC
Relay Output:	Load rating for relay contacts: 0.50A at 125 VAC or 1A at 25 VAC

GENERAL

Dimensions:	See Figure 11.
Operating Temperature:	32° to 122°F (0° to 50°C)
Unit Weight:	8 lb (3.63 kg)

MECHANICAL

Connectors	
Relay Inputs:	Screw terminals
Power:	3-wire receptacle, #18 AWG
RS-485:	Two RJ-45 connectors
RS-232:	One DB9 connector (factory use only)

(Design and product specifications subject to change without notice.)

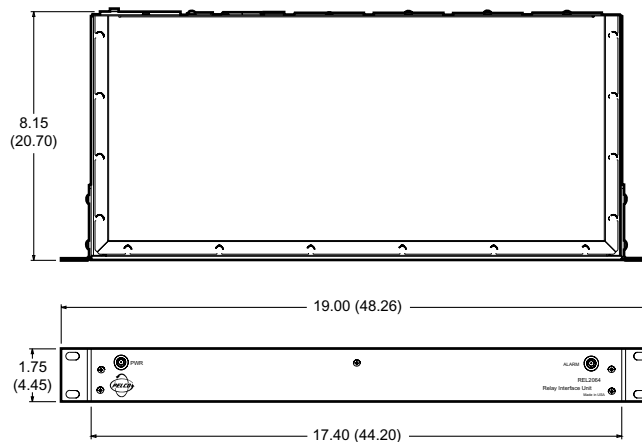

NOTE: VALUES IN PARENTHESES ARE CENTIMETERS;
ALL OTHERS ARE INCHES

00695

Figure 11. REL2064 Dimension Diagram

REGULATORY NOTICES

This equipment has been tested and found to comply with the limits of a Class B digital device, pursuant to part 15 of the FCC rules. These limits are designed to provide reasonable protection against harmful interference in a residential installation. This equipment generates, uses, and can radiate radio frequency energy and, if not installed and used in accordance with the instructions, may cause harmful interference to radio communications. However there is no guarantee that the interference will not occur in a particular installation. If this equipment does cause harmful interference to radio or television reception, which can be determined by turning the equipment off and on, the user is encouraged to try and correct the interference by one or more of the following measures:

- Reorient or relocate the receiving antenna.
- Increase the separation between the equipment and the receiver.
- Connect the equipment into an outlet on a circuit different from that to which the receiver is connected.
- Consult the dealer or an experienced radio/TV technician for help.

WARRANTY AND RETURN INFORMATION

WARRANTY

Pelco will repair or replace, without charge, any merchandise proved defective in material or workmanship for a period of one year after the date of shipment. Exceptions to this warranty are as noted below:

- Five years on Pelco manufactured cameras (CC3500/CC3600/CC3700 and MC3500/MC3600 Series); two years on all other cameras.
- Three years on Genex® Series (multiplexers, server, and keyboard) and 090 Series Camclosure® Camera System.
- Two years on 100/150, 200, and 300 Series Camclosure Camera Systems.
- Two years on all standard motorized or fixed focal length lenses.
- Two years on Legacy®, CM6700/CM6800/CM8500/CM9500/CM9740/CM9760 Matrix, DF5 and DF8 Series Fixed Dome products.
- Two years on Spectra®, Esprit®, and PS20 Scanners, including when used in continuous motion applications.
- Two years on Esprit and VW5700 series window wiper (excluding wiper blades).
- Eighteen months on DX Series digital video recorders.
- One year (except video heads) on video cassette recorders (VCRs). Video heads will be covered for a period of six months.
- Six months on all pan and tilts, scanners or preset lenses used in continuous motion applications (that is, preset scan, tour and auto scan modes).

Pelco will warrant all replacement parts and repairs for 90 days from the date of Pelco shipment. All goods requiring warranty repair shall be sent freight prepaid to Pelco, Clovis, California. Repairs made necessary by reason of misuse, alteration, normal wear, or accident are not covered under this warranty.

Pelco assumes no risk and shall be subject to no liability for damages or loss resulting from the specific use or application made of the Products. Pelco's liability for any claim, whether based on breach of contract, negligence, infringement of any rights of any party or product liability, relating to the Products shall not exceed the price paid by the Dealer to Pelco for such Products. In no event will Pelco be liable for any special, incidental or consequential damages (including loss of use, loss of profit and claims of third parties) however caused, whether by the negligence of Pelco or otherwise.

The above warranty provides the Dealer with specific legal rights. The Dealer may also have additional rights, which are subject to variation from state to state.

If a warranty repair is required, the Dealer must contact Pelco at (800) 289-9100 or (559) 292-1981 to obtain a Repair Authorization number (RA), and provide the following information:

1. Model and serial number
2. Date of shipment, P.O. number, Sales Order number, or Pelco invoice number
3. Details of the defect or problem

If there is a dispute regarding the warranty of a product which does not fall under the warranty conditions stated above, please include a written explanation with the product when returned.

Method of return shipment shall be the same or equal to the method by which the item was received by Pelco.

RETURNS

In order to expedite parts returned to the factory for repair or credit, please call the factory at (800) 289-9100 or (559) 292-1981 to obtain an authorization number (CA number if returned for credit, and RA number if returned for repair).

All merchandise returned for credit may be subject to a 20% restocking and refurbishing charge.

Goods returned for repair or credit should be clearly identified with the assigned CA or RA number and freight should be prepaid. Ship to the appropriate address below.

If you are located within the continental U.S., Alaska, Hawaii or Puerto Rico:

Service Department
Pelco
3500 Pelco Way
Clovis, CA 93612-5699

If you are located outside the continental U.S., Alaska, Hawaii or Puerto Rico:

Intermediate Consignee
American Overseas Air Freight
320 Beach Road
Burlingame, CA 94010
USA

Ultimate Consignee
Pelco
3500 Pelco Way
Clovis, CA 93612-5699
USA

REVISION HISTORY

Manual #	Date	Comments
C1518M	5/01	Original version.
C1518M-A	11/02	Updated manual to new format. Revised Table A and updated Table B.



World Headquarters
3500 Pelco Way
Clovis, California 93612 USA

USA & Canada
Tel: 800/289-9100
Fax: 800/289-9150

International
Tel: 1-559/292-1981
Fax: 1-559/348-1120

www.pelco.com

ISO9001

Orangeburg, New York | Las Vegas, Nevada | Eindhoven, The Netherlands | Wokingham, United Kingdom | Montreal, Canada