



48NLT, NMT, NET, NHT AND NVT 018-060 Packaged Heating/Cooling Units

Installation, Start-Up and Service Instructions

CONTENTS

	Page
SAFETY CONSIDERATIONS	1
General	1
Job Data	1
RECEIVING AND INSTALLATION	1-10
Step 1 – Check Equipment	1
• IDENTIFY MACHINE	
• INSPECT SHIPMENT	
Step 2 – Provide Unit Support	4
• ROOF CURB	
• SLAB MOUNT	
Step 3 – Provide Clearances	4
Step 4 – Rig and Place Unit	4
Step 5 – Connect Condensate Drain	5
Step 6 – Install Venting	6
Step 7 – Install Gas Piping	6
Step 8 – Install Duct Connections	7
Step 9 – Install Electrical Connections	8
• HIGH VOLTAGE CONNECTIONS	
• SPECIAL PROCEDURES FOR 208-V OPERATION	
• CONTROL VOLTAGE CONNECTIONS	
• HEAT ANTICIPATOR SETTING	
• TRANSFORMER CIRCUIT PROTECTION	
PRE-START-UP	10,11
START-UP	11-20
MAINTENANCE	20-26

NOTE TO INSTALLER — Before the installation, READ THESE INSTRUCTIONS CAREFULLY AND COMPLETELY. Also, make sure the User's Manual and Replacement Guide are left with the unit after installation.

SAFETY CONSIDERATIONS

Installation and servicing of air conditioning equipment can be hazardous due to system pressure and electrical components. Only trained and qualified personnel should install, repair or service air conditioning equipment.

Untrained personnel can perform basic maintenance functions of cleaning coils and filters. All other operations should be performed by trained service personnel. When working on air conditioning equipment, observe precautions in the literature, tags and labels attached to the unit and other safety precautions that may apply.

Follow all safety codes. Wear safety glasses and work gloves. Use quenching cloth for unbrazing operations. Have fire extinguisher available for all brazing operations.

▲ WARNING

Improper installation, adjustment, alteration, service, maintenance or use can cause carbon monoxide poisoning, fire or an explosion which can result in personal injury or unit damage. Consult a qualified installer, service agency or gas supplier for information or assistance. The qualified installer or agency must use only factory-authorized kits or accessories when modifying this product.

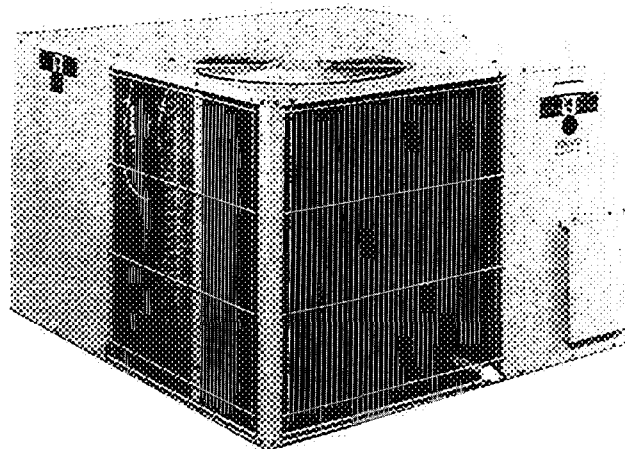

Fig. 1 — Model 48NLT, NMT, NET, NHT and NVT

▲ WARNING

Before performing service or maintenance operations on unit, turn off unit main power switch. Electrical shock could cause personal injury.

General — The 48NLT, NMT, NET, NHT and NVT units are fully self-contained, combination gas heating/cooling units designed for outdoor installation. See Fig. 1. The units are shipped in a vertical configuration and may be installed either on a rooftop or converted to horizontal configuration when placed on a ground-level cement slab.

Job Data — Necessary information consists of: machine location drawings, piping drawings, field wiring diagrams and rigging guide.

RECEIVING AND INSTALLATION

Step 1 – Check Equipment

IDENTIFY MACHINE — The machine model number and serial number are stamped on machine identification plate. Check this information against shipping papers and job data.

INSPECT SHIPMENT — Inspect for shipping damage while machine is still on shipping pallet. If machine appears to be damaged or is torn loose from its anchorage, have it examined by transportation inspectors before removal. Forward claim papers directly to transportation company. Manufacturer is not responsible for any damage incurred in transit.

Check all items against shipping list. Immediately notify the nearest Carrier Air Conditioning office if any item is missing.

To prevent loss or damage, leave all parts in original packages until installation.

UNIT	ELECTRICAL CHARACTERISTICS	UNIT WT				CORNER WT LB/KG			
		LB	KG	A	B	C	D		
48NLT018	208/230/1/60	450	204	99/45	126/57	127/58	100/45	99/45	
48NLT024	208/230/1/60	454	206	100/45	127/58	129/59	101/46	100/45	
48NLT030	208/230/1/60	470	214	103/47	132/60	132/60	103/47	103/47	
48NMT030	208/230/1/60	476	216	105/48	133/60	133/60	105/48	105/48	
48NHT030	208/230/1/60	480	218	106/48	134/61	134/61	106/48	106/48	
48NLT036	208/230/1/60, 208/230/3/60, 460/3/60	486	222	107/49	136/62	136/62	107/49	107/49	
48NMT036	208/230/1/60, 208/230/3/60, 460/3/60	490	222	108/49	137/62	137/62	108/49	108/49	
48NET036	208/230/1/60, 208/230/3/60, 460/3/60	490	222	108/49	137/62	137/62	108/49	108/49	
48NLT042	208/230/1/60, 208/230/3/60, 460/3/60	496	224	109/49	139/63	139/63	109/49	109/49	
48NMT042	208/230/1/60, 208/230/3/60, 460/3/60	500	228	110/50	140/64	140/64	110/50	110/50	
48NET042	208/230/1/60, 208/230/3/60, 460/3/60	500	228	110/50	140/64	140/64	110/50	110/50	

NOTE: Clearances must be maintained to prevent recirculation of air from condenser fan discharge.

REQUIRED CLEARANCES TO COMBUSTIBLE MATERIAL — in. (mm)
 Maximum Extension of Overhang 48 (1219.2)
 Unit Top 36 (914.4)
 Duct Side of Unit 6 Min. (152.4 Min.)
 Side Opposite Ducts 30 (762.0)
 Bottom of Unit 30 (762.0)

REQUIRED CLEARANCES FOR SERVICING — in. (mm)
 Blower Access Panel Side 30 (762.0)
 Control Box Access Side 30 (762.0)

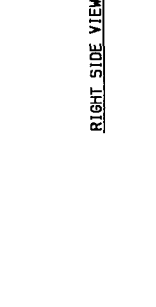
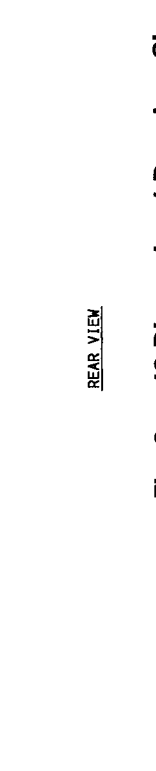
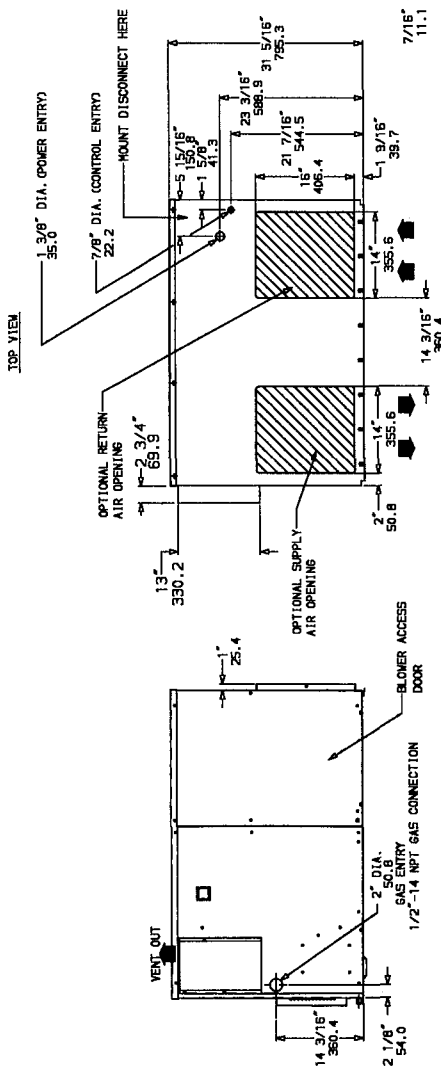
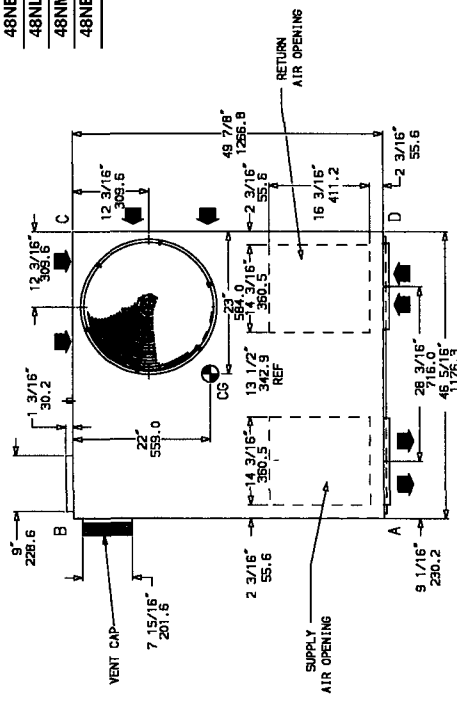

Fig. 2 — 48 Dimensional Drawing, Sizes NLT018 — NET042

UNIT	ELECTRICAL CHARACTERISTICS				CORNER WT LB/KG			
	LB	KG	A	B	C	D		
48NHT036	208/230/1/60, 208/230/3/60, 460/3/60	530	241	117/63	147/67	148/67	118/54	
48NVT036	208/230/1/60, 208/230/3/60, 460/3/60	536	243	119/54	149/67	149/68	120/54	
48NHT042	208/230/1/60, 208/230/3/60, 460/3/60	550	249	122/55	152/69	153/69	123/56	
48NVT042	208/230/1/60, 208/230/3/60, 460/3/60	556	252	124/56	153/69	154/70	125/57	
48NLT048	208/230/1/60, 208/230/3/60, 460/3/60	574	261	128/58	158/72	159/72	129/59	
48NMT048	208/230/1/60, 208/230/3/60, 460/3/60	580	263	130/59	159/72	160/73	131/59	
48NHT048	208/230/1/60, 208/230/3/60, 460/3/60	586	265	131/59	161/73	162/73	132/60	
48NVT048	208/230/1/60, 208/230/3/60, 460/3/60	604	274	136/62	165/75	166/75	137/62	
48NLT060	208/230/1/60, 208/230/3/60, 460/3/60	610	277	138/63	166/75	167/76	139/63	
48NMT060	208/230/1/60, 208/230/3/60, 460/3/60	616	280	139/63	168/76	169/77	140/64	
48NVT060	208/230/1/60, 208/230/3/60, 460/3/60	616	280	139/63	168/76	169/77	140/64	

NOTE. Clearances must be maintained to prevent recirculation of air from condenser-fan discharge.

REQUIRED CLEARANCES TO COMBUSTIBLE MATERIAL — in. (mm)

Maximum Extension of Overhang 48 (1219.2)

Unit Top 36 (914.4)

Side Opposite Ducts 6 Min. (152.4 Min.)

Bottom of Unit 30 (762.0)

REQUIRED CLEARANCES FOR SERVICING — in. (mm)

Blower Access Panel Side 30 (762.0)

Control Box Access Side 30 (762.0)

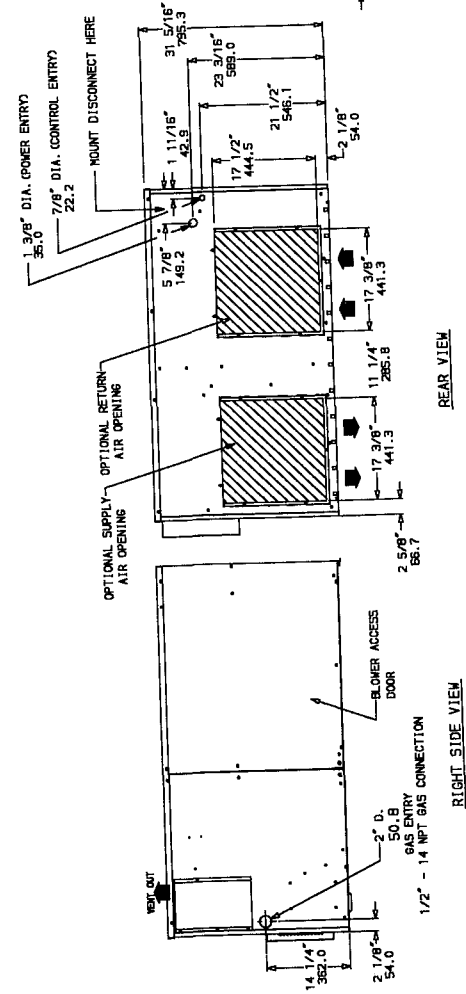
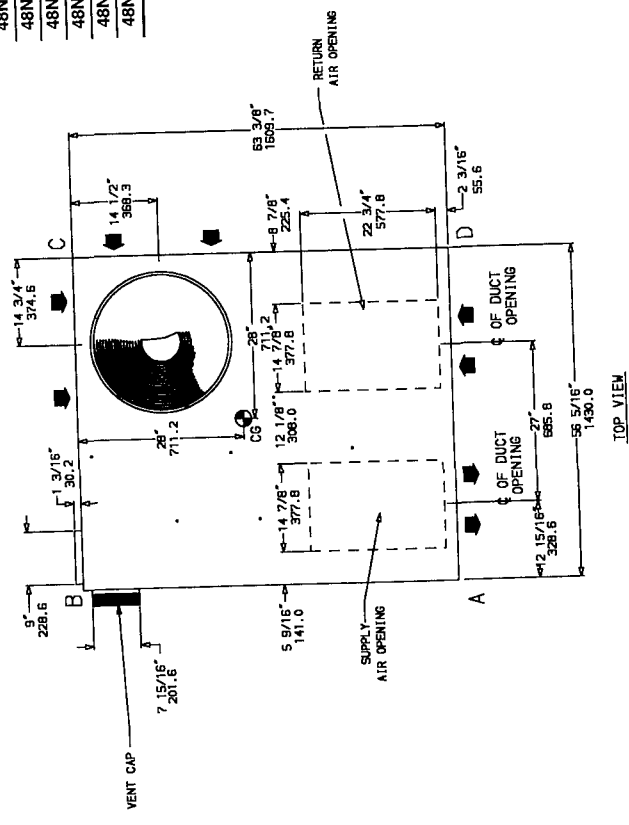

Fig. 3 — 48 Dimensional Drawing, Sizes NHT036 — NVT060

Table 1 – Physical Data

UNIT SIZE 48	NLT018	NLT024	NHT024	NLT030	NMT030	NHT030	NLT036	NMT036	NET036	NHT036	NVT036	
NOMINAL CAPACITY (ton)	1½	2		2½			3					
OPERATING WEIGHT (lb)	450	454	460	470	476	480	486	490	490	530	536	
COMPRESSORS	Reciprocating Hermetic, 3500 Rpm											
Quantity	1											
REFRIGERANT*	R-22											
REFRIGERANT METERING DEVICE	AccuRater® Piston											
CONDENSER COIL												
Rows	1						2					
Fins/in.	20						20					
CONDENSER FAN												
Nominal Airflow (Cfm)				2000			2500			2500** 3000††		
Nominal Speed (Rpm)				825			1100			825** 1100††		
Quantity...Diameter (In.)							1 20					
Motor Hp (single-phase)				½			¼		¼			
(three-phase)				—			¼		¼			
EVAPORATOR COIL												
Rows	3											
Fins/in.	14											
EVAPORATOR FAN												
Nominal Cfm	600	800		1000			1100	1200		1200		
Nominal Speed (Rpm)												
Diameter x Width (In.)				10 x 8			1100		10 x 10			
Motor Hp (single-phase)				½			½		¾		¾	
(three-phase)				—			½		¾		¾	
FURNACE SECTION												
Burner Orifice No. (Qty...drill size)												
Natural Gas	2 44	2 44	3 44	2. 44	3 44	4 44	3 44	4 44	4 42	5. 44	6 .44	
Burner Orifice No. (Qty...drill size)												
Propane Gas	2. 55	2 55	3 55	2 55	3 55	4 55	3 .55	4 55	4 54	5 55	6 55	
Pilot Orifice Diameter (in. ...drill size)												
Natural Gas	018 77											
Pilot Orifice Diameter (in.)												
Propane Gas	.009											
RETURN-AIR FILTERS (sq In.)†												
Disposable	288		528		624		720					
Cleanable	192		352		416		480					

*Operating charge is listed on unit nameplate

†Required field-supplied filter areas are based on the larger of the ARI-rated (Air Conditioning & Refrigeration Institute) cooling airflow or the heating airflow at a velocity of 300 ft/min for disposable type or 450 ft/min for high-capacity type. Air filter pressure drop must not exceed 0.08 in wg

**Single-phase units

††Three-phase units

Step 2 – Provide Unit Support

ROOF CURB — Install accessory roof curb in accordance with instructions shipped with curb. Install insulation, cant strips, roofing and flashing. Ductwork must be attached to curb.

IMPORTANT: The gasketing of the unit to the roof curb is critical for water integrity. Install gasketing material supplied with the roof curb. Improperly applied gasketing also can result in air leaks and poor unit performance.

Curb should be level to within ¼ inch. This is necessary for unit drain to function properly. Refer to Accessory Roof Curb Installation Instructions for additional information as required.

SLAB MOUNT — Place the unit on a solid, level concrete pad that is a minimum of 4-in. thick with 2-in. above grade. The slab should extend approximately 2-in. beyond the casing on all 4 sides of the unit. Install a gravel apron in front of condenser-air inlets to prevent obstruction of airflow by grass or shrubs. Do not secure the unit to the slab *except* when required by local codes.

Step 3 – Provide Clearances — The required minimum operating and service clearances are shown in Fig. 2 and 3. Adequate combustion, ventilation and condenser air must be provided.

The condenser fan discharges through the top of the unit. Be sure that the fan discharge does not recirculate to the condenser coil. Do not locate the unit in either a corner or under an overhead obstruction. The minimum clearance

under a partial overhang (such as a normal house overhang) is 48-in. above the unit top. The maximum horizontal extension of a partial overhang must not exceed 48 inches.

⚠ CAUTION

Do not restrict condenser airflow. An air restriction at either the outdoor-air inlet (the entire surface of the outdoor coil) or the fan discharge can be detrimental to compressor life.

Do not place the unit where water, ice or snow from an overhang or roof will damage or flood the unit. Do not install the unit on carpeting, tile or other combustible materials. The unit may be installed on wood flooring or on Class A, B or C roof covering materials.

Step 4 – Rig and Place Unit — Use spreader bars and crate top when rigging the unit. The units must be rigged for lifting as shown in Fig. 4. Refer to Fig. 4 for rigging weight and Table 1 for operating weight. *Use extreme caution to prevent damage when moving the unit. Unit must remain in an upright position during all rigging and moving operations.* The unit must be level for proper condensate drainage; therefore, the ground-level pad or accessory roof-mounting curb must be level before setting the unit in place. When a field-fabricated support is used, be sure that the support is level and properly supports the unit.

⚠ CAUTION

When installing the unit on a rooftop, be sure the roof will support the additional weight. Refer to Fig. 4 for corner weight information.

Table 1 – Physical Data (cont)

UNIT SIZE 48	NLT 042	NMT 042	NET 042	NHT 042	NVT 042	NLT 048	NMT 048	NHT 048	NVT 048	NLT 060	NMT 060	NHT 060	NVT 060			
NOMINAL CAPACITY (ton)	3½					4				5						
OPERATING WEIGHT (lb)	496	500	500	550	556	574	580	586	586	604	610	616	616			
COMPRESSORS	Reciprocating Hermetic, 3500 Rpm															
Quantity	1															
REFRIGERANT*	R-22															
REFRIGERANT METERING DEVICE	AccuRater® Piston															
CONDENSER COIL																
Rows	2															
Fins/in.	20															
CONDENSER FAN																
Nominal Airflow (Cfm)	2500			3000			1100			3500						
Nominal Speed (Rpm)	1 20															
Quantity...Diameter (in.)	1															
Motor Hp (single-phase)	1															
Motor Hp (three-phase)	1															
EVAPORATOR COIL																
Rows	3						4									
Fins/in.	14						14									
EVAPORATOR FAN																
Nominal Cfm	1400						1100			1600			2000			
Nominal Speed (Rpm)	10 x 10															
Diameter x Width (in.)	10 x 10															
Motor Hp (single-phase)	1															
Motor Hp (three-phase)	1															
FURNACE SECTION																
Burner Orifice No. (Qty...drill size) Natural Gas	3 44	4 44	4 42	5 44	6 44	3 44	4 44	5 44	6 42	3 44	4 44	5 44	6 42			
Burner Orifice No. (Qty...drill size) Propane Gas	3 55	4 55	4 54	5 55	6 55	3 55	4 55	5 55	6 54	3 55	4 55	5 55	6 54			
Pilot Orifice Diameter (in. ...drill size) Natural Gas	018 77															
Pilot Orifice Diameter (in.) Propane Gas	009															
RETURN-AIR FILTERS (sq in.)†																
Disposable	720						816						960			
Cleanable	480						544						640			

*Operating charge is listed on unit nameplate

†Required field-supplied filter areas are based on the larger of the ARI-rated (Air Conditioning & Refrigeration Institute) cooling airflow or the heating airflow at a velocity of 300 ft/min for disposable type or 450 ft/min for high-capacity type. Air filter pressure drop must not exceed 0.08 in wg

Step 5 – Connect Condensate Drain

NOTE: When installing condensate drain connection be sure to comply with local codes and restrictions.

The unit disposes of condensate water through a ¾-in. NPT drain fitting. See Fig. 2 and 3 for location.

Install a 2-in. trap at the drain fitting to ensure proper drainage. See Fig. 5. Make sure the outlet of the trap is at least one-in. lower than the unit drain pan connection to

prevent the pan from overflowing. Prime the trap with water.

If the installation requires draining the condensate water away from the unit, connect a drain tube using a minimum of 7/8-in. OD copper tubing, ¾-in. galvanized pipe or ¾-in. plastic pipe. *Do not undersize the tube.* Pitch the drain tube downward at a slope of at least one inch in every 10 ft of horizontal run. Be sure to check the drain tube for leaks.

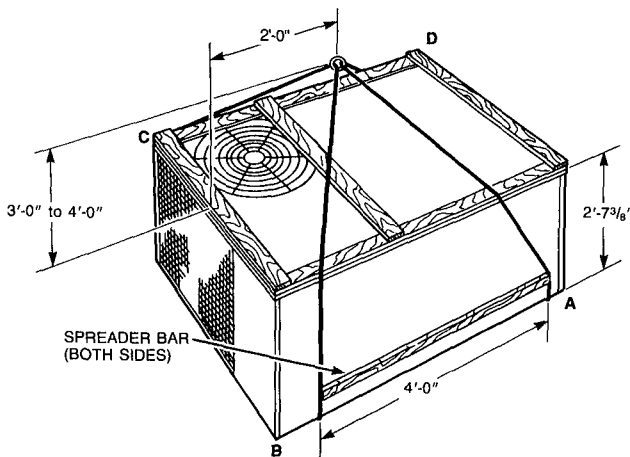

UNIT 48	CORNER WT (LB)			
	A	B	C	D
NLT018	99	126	126	99
NLT024	100	127	127	100
NHT024	101	129	129	101
NLT030	103	132	132	103
NMT030	105	133	133	105
NHT030	106	134	134	106
NLT036	107	136	136	107
NMT036	108	137	137	108
NET036	108	137	137	108
NHT036	117	147	148	118
NVT036	119	148	149	120
NLT042	109	139	139	109
NMT042	110	140	140	110
NET042	110	140	140	110
NHT042	117	147	147	117
NVT042	124	153	154	125
NLT048	128	158	159	129
NMT048	130	159	160	131
NHT048	131	161	162	132
NVT048	131	161	162	132
NLT060	136	165	166	137
NMT060	138	166	167	139
NHT060	139	168	169	140
NVT060	139	168	169	140

Fig. 4 – Suggested Rigging

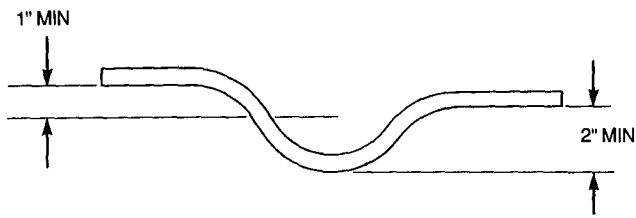

Fig. 5 – Condensate Trap

Condensate water can be drained directly onto the roof in rooftop installations (where permitted) or onto a gravel apron in ground-level installations. When using a gravel apron, make sure it slopes away from the unit.

Step 6 – Install Venting – The vent cap assembly is shipped in the burner compartment. Remove the access door to locate the assembly.

⚠ CAUTION

The venting system is designed to ensure proper venting. The vent cap assembly must be installed as indicated in this section of the unit Installation Instructions.

NOTE: Screw holes in the flue assembly and the unit flue panel are *not* symmetrically located. Make sure they are oriented properly when installing these components.

Refer to Fig. 6 and install the vent cap as follows:

1. Place vent cap assembly over flue panel. Orient screw holes in vent cap with holes in flue panel.

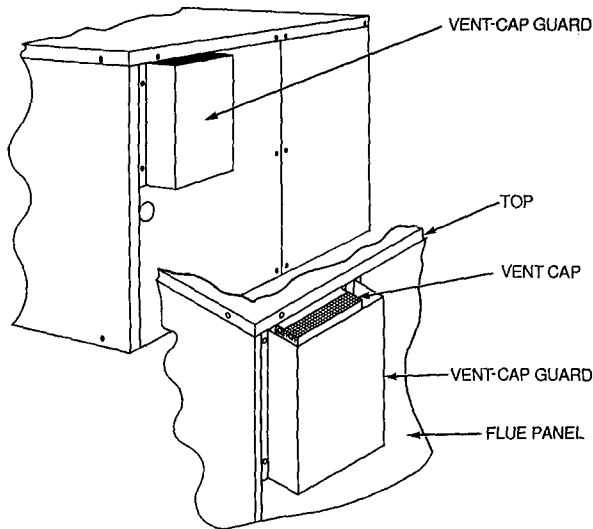

Fig. 6 – Vent Cap Assembly

2. Secure vent cap in place by inserting the single screw on the right side of vent cap.
3. Place the vent cap guard over the vent cap. Orient holes in vent cap guard with holes in vent cap and flue panel.
4. Secure the entire assembly with the remaining 2 screws on the left side of vent cap and vent-cap guard assembly.

Step 7 – Install Gas Piping – The gas supply pipe enters the unit through the access hole provided. The gas connection to the unit is made to the 1/2-in. FPT gas inlet on the manual shutoff or gas valve.

Install a separate gas supply line that runs directly from the meter to the heating section. Refer to Table 2 and the National Fuel Gas Code (NFGC) for gas pipe sizing. *Do not use cast-iron pipe.* It is recommended that black iron pipe is used. Check the local utility for recommendations concerning existing lines. Choose a supply pipe that is large enough to keep the pressure loss as low as practical. *Never use pipe smaller than the 1/2-in. FPT gas inlet on the unit gas valve.*

For natural gas applications, the gas pressure at unit gas connection must not be less than 5 in. wg or greater than 13 in. wg while the unit is operating. For propane applications, the gas pressure must not be less than 11 in. wg or greater than 13 in. wg at the unit connection.

When installing the gas supply line, observe local codes pertaining to gas pipe installations. Refer to the NFGC ANSI (American National Standards Institute) Z223.1-1988 NFPA (National Fire Protection Association) 54-1988 (in Canada, CAN/CGA [Canadian Gas Association] B149.1, (2)-M86). In the absence of local building codes, adhere to the following pertinent recommendations:

1. Avoid low spots in long runs of pipe. Grade all pipe 1/4 inch in every 15 ft to prevent traps. Grade all horizontal runs downward to risers. Use risers to connect to heating section and to meter.
2. Protect all segments of piping system against physical and thermal damage. Support all piping with appropriate straps, hangers, etc. Use a minimum of one hanger every 6 ft. For pipe sizes larger than 1/2 in., follow recommendations of national codes.
3. Apply joint compound (pipe dope) sparingly and only to male threads of joint when making pipe connections. Use only pipe dope that is resistant to action of liquefied petroleum gases as specified by local and/or national codes. *Never use Teflon tape.*
4. Install sediment trap in riser leading to heating section. This drip leg functions as a trap for dirt and condensate. Install trap where condensate cannot freeze. Install this sediment trap by connecting a piping tee to riser leading to heating section, so that straight-through section of tee is vertical. See Fig. 7. Then, connect capped nipple into lower end of tee. Extend capped nipple below level of gas controls.

Table 2 – Maximum Gas Glow Capacity*

NOMINAL IRON PIPE, SIZE (in.)	INTERNAL DIAMETER (in.)	LENGTH OF PIPE, FT†													
		10	20	30	40	50	60	70	80	90	100	125	150	175	200
1/2	.622	175	120	97	82	73	66	61	57	53	50	44	40	—	—
3/4	.824	360	250	200	170	151	138	125	118	110	103	93	84	77	72
1	1.049	680	465	375	320	285	260	240	220	205	195	175	160	145	135
1 1/4	1.380	1400	950	770	600	580	530	490	460	430	400	360	325	300	280
1 1/2	1.610	2100	1460	1180	990	900	810	750	690	650	620	550	500	460	430

*Capacity of pipe in cu ft of gas per hr for gas pressure of 0.5 psig or less. Pressure drop of 0.5 in. wg (based on a 0.60 specific gravity gas) Refer to Table C-4, NFPA 54-1984

†This length includes an ordinary number of fittings

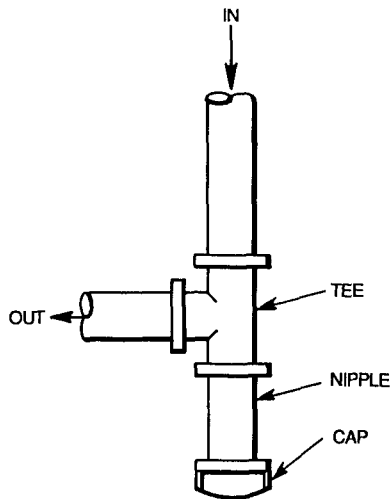
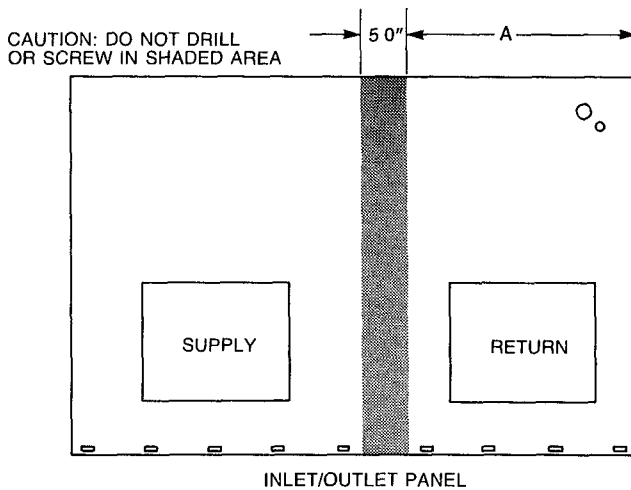

Fig. 7 – Sediment Trap



	Size	"A"
Small Cabinet	NLT018—NET042	20½ in.
Large Cabinet	NHT036—NVT060	25½ in.

Fig. 8 – Location of Coil Area Not to be Drilled

5. Install an accessible, external, manual main shutoff valve in gas supply pipe within 6 ft of heating section.
6. Install ground-joint union close to heating section between unit manual shutoff and external manual main shutoff valve.
7. Pressure-test all gas piping in accordance with local and national plumbing and gas codes before connecting piping to unit.

NOTE: Pressure test the gas supply system *after* the gas supply piping is connected to the gas valve. The supply piping must be disconnected from the gas valve during the

testing of the piping systems when test pressure in excess of 0.5 psig. Pressure test the gas supply piping system at pressures equal to or less than 0.5 psig. The unit heating section must be isolated from the gas piping system by closing the external main manual shutoff valve and slightly opening the ground-joint union.

⚠ CAUTION

Unstable operation may occur when the gas valve and manifold assembly are forced out of position while connecting improperly-routed rigid gas piping to the gas valve. Use a backup wrench when making connection to avoid strain on, or distortion of, the gas control piping.

⚠ CAUTION

If a flexible conductor is required or allowed by the authority having jurisdiction, black iron pipe shall be installed at the gas valve and shall extend a minimum of 2 in. outside the unit casing.

⚠ WARNING

Never use a match or other open flame when checking for gas leaks. Never purge gas line into combustion chamber. Failure to follow this warning could result in an explosion causing personal injury or death.

8. Check for gas leaks at the field-installed and factory-installed gas lines after all piping connections have been completed. Use soap-and-water solution (or method specified by local codes and/or regulations).

Step 8 – Install Duct Connections – The unit has duct flanges on the supply- and return-air openings on the side and bottom of the unit. See Fig. 2 and 3 for connection sizes and locations.

NOTE: The design and installation of the duct system must be in accordance with the standards of the NFPA for installation of nonresidence-type air conditioning and ventilating systems, NFPA No. 90A or residence-type, NFPA No. 90B; and/or local codes and residence-type, NFPA No. 90B; and/or local codes and ordinances.

Adhere to the following criteria when selecting, sizing and installing the duct system:

1. The unit is shipped in vertical configuration. To convert unit to horizontal application, remove side duct covers, save screws and install the covers on bottom duct openings.
2. Select and size ductwork, supply-air registers and return-air grilles according to ASHRAE (American Society of Heating, Refrigeration and Air Conditioning Engineers) recommendations.

⚠ CAUTION

When drilling the duct-system fastening holes into the side of the unit instead of the unit duct flanges, use extreme care to avoid puncturing the coil or coil tubes. See Fig. 8.

3. Use flexible transition between rigid ductwork and unit to prevent transmission of vibration. The transition may be screwed or bolted to duct flanges. Use suitable gaskets to ensure weather- and airtight seal.
4. Install external, field-supplied air filter(s) in return-air ductwork where it is easily accessible for service. Recommended filter sizes are shown in Table 1.
5. Size all ductwork for maximum required airflow (either heating or cooling) for unit being installed. Avoid abrupt duct size increases or decreases.
6. Adequately insulate and weatherproof all ductwork located outdoors. Insulate ducts passing through unconditioned space, and use vapor barrier in accordance with latest issue of SMACNA (Sheet Metal and Air Conditioning Contractors National Association) and ACCA (Air Conditioning Contractors of America) minimum installation standards for heating and air conditioning systems. Secure all ducts to building structure.
7. Flash, weatherproof and vibration-isolate all openings in building structure in accordance with local codes and good building practices.

3. Be sure that high-voltage power to unit is within operating voltage range indicated on unit rating plate. On 3-phase units, ensure that phases are balanced within 2%. Consult local power company for correction of improper voltage and/or phase balance.
4. Insulate low-voltage wires for highest voltage contained within conduit when low-voltage control wires are run in same conduit as high-voltage wires.
5. Do not damage internal components when drilling through any panel to mount electrical hardware, conduit, etc.

HIGH-VOLTAGE CONNECTIONS — The unit must have a separate electrical service with a field-supplied, waterproof, fused disconnect switch mounted at, or within sight from, the unit. Refer to the unit rating plate for maximum fuse/circuit breaker size and minimum circuit amps (ampacity) for wire sizing. See Table 3 for electrical data.

The field-supplied disconnect switch box may be mounted on the unit over the high-voltage inlet hole in the control corner panel. See Fig. 2 and 3.

Proceed as follows to complete the high-voltage connections to the unit:

1. Connect ground lead to chassis ground connection when using separate ground wire.
2. Run high-voltage leads into unit control box and connect to contactor. See unit wiring label, and Fig. 9.

Step 9 – Install Electrical Connections

⚠ WARNING

The unit cabinet must have an uninterrupted, unbroken electrical ground to minimize the possibility of personal injury if an electrical fault should occur. This ground may consist of an electrical wire connected to the unit ground lug in the control compartment, or conduit approved for electrical ground when installed in accordance with NEC (National Electrical Code) ANSI/NFPA (latest edition) (in Canada, Canadian Electrical Code CSA C22.1) and local electrical codes. *Do not use gas piping as an electrical ground.* Failure to adhere to this warning could result in personal injury or death.

⚠ CAUTION

Failure to follow these precautions could result in damage to the unit being installed:

1. Make all electrical connections in accordance with NEC ANSI/NFPA (latest edition) and local electrical codes governing such wiring. In Canada, all electrical connections must be in accordance with CSA Standard C22.1 Canadian Electrical Code Part 1 and applicable local codes. Refer to unit wiring diagram.
2. Use only *copper* conductor for connections between field-supplied electrical disconnect switch and unit. **DO NOT USE ALUMINUM WIRE.**

⚠ CAUTION

**TRANSFORMER CONTAINS AUTO
RESET OVERCURRENT PROTECTOR.**

**IT MAY RESET WITHOUT WARNING
STARTING HEATING OR COOLING
SECTION OF THIS PRODUCT.**

**DISCONNECT POWER PRIOR TO
SERVICING.**

**THIS COMPARTMENT MUST BE
CLOSED EXCEPT WHEN SERVICING.**

316056-201 REV A

Fig. 9 – Transformer Label

Table 3 – Electrical Data

UNIT SIZE	NOMINAL V-PH-HZ	MODEL NO. 48	VOLTAGE RANGE		COMPR		CONDENSER-FAN MOTOR	EVAPORATOR-FAN MOTOR	AWG MIN WIRE SIZE	POWER SUPPLY	
			Min	Max	RLA	LRA	FLA	FLA		MCA	MOCP
018	208/230-1-60	NLT018	187	253	8.2	49.0	0.8	2.5	14	13.6	20
024	208/230-1-60	NLT024 NHT024	187	253	11.6 11.6	61.0 61.0	0.8	2.5	12	17.1	25
030	208/230-1-60	NLT030 NMT030 NHT030	187	253	14.3	86.0	0.8	2.5 2.5 3.0	10	21.2 21.2 21.7	30
		NLT036 NMT036 NET036 NHT036 NVT036						3.0 3.0 4.5 4.5 4.5		30.9 30.9 32.4 32.4 32.4	
036	208/230-1-60	NLT036 NMT036 NET036 NHT036 NVT036	187	253	21.1	100.0	1.5	3.0 3.0 4.5 4.5 4.5	8	23.3 23.3 24.8 25.1 25.1	40
	208/230-3-60	NLT036 NMT036 NET036 NHT036 NVT036	187	253	14.7	67.0	1.9 1.9 1.9 2.2 2.2	3.0 3.0 4.5 4.5 4.5	10	23.3 23.3 24.8 25.1 25.1	30
	460-3-60	NLT036 NMT036 NET036 NHT036 NVT036	414	506	7.1	34.0	1.2	1.5 1.5 2.3 2.3 2.3	14	11.6 11.6 12.4 12.4 12.4	15
042	208/230-1-60	NLT042 NMT042 NET042 NHT042 NVT042	187	253	23.9	95.4	1.5	3.0 3.0 4.5 4.5 4.5	8	34.3 34.3 35.9 35.9 35.9	50
	208/230-3-60	NLT042 NMT042 NET042 NHT042 NVT042	187	253	15.3	82.0	1.9 1.9 1.9 2.2 2.2	3.0 3.0 4.5 4.5 4.5	10	24.0 24.0 25.5 25.8 25.8	35 35 40 40 40
	460-3-60	NLT042 NMT042 NET042 NHT042 NVT042	414	506	7.7	41.0	1.2	1.5 1.5 2.3 2.3 2.3	14	12.3 12.3 13.1 13.1 13.1	20
048	208/230-1-60	NLT048 NMT048 NHT048 NVT048	187	253	26.5	114.0	2.1	4.5 4.5 4.5 6.2	8 6	39.7 39.7 39.7 41.4	60
	208/230-3-60	NLT048 NMT048 NHT048 NVT048	187	253	16.8	84.0	2.2	4.5 4.5 4.5 6.2	10	27.7 27.7 27.7 29.4	40
	460-3-60	NLT048 NMT048 NHT048 NVT048	187	253	8.2	42.0	1.2	2.3 2.3 2.3 3.2	14	13.8 13.8 13.8 14.7	20
060	208/230-1-60	NLT060 NMT060 NHT060 NVT060	187	253	30.7	135.0	2.1	6.2	6	46.7	60
	208/230-3-60	NLT060 NMT060 NHT060 NVT060	187	253	21.4	130.0	2.2	6.2	8	35.5	50
	460-3-60	NLT060 NMT060 NHT060 NVT060	414	506	10.4	55.0	1.2	3.2	12	17.4	25

- AWG – American Wire Gage
- FLA – Full Load Amps
- LRA – Locked Rotor Amps
- MCA – Minimum Circuit Amps
- MOCP – Maximum Overcurrent Protection
- NEC – National Electrical Code
- RLA – Rated Load Amps

NOTES:

1 In compliance with NEC requirements for multimotor and combination load and equipment (refer to NEC Articles 430 and 440), the overcurrent protective device for the unit shall be fuse or HACR breaker

2 Unbalanced 3-Phase Supply Voltage

Never operate a motor where a phase imbalance in supply voltage is greater than 2%. Use the following formula to determine the % voltage imbalance.

$$\% \text{ Voltage Imbalance} = 100 \times \frac{\text{max voltage deviation from average voltage}}{\text{average voltage}}$$

Example: Supply voltage is 460-3-60

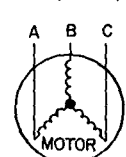

- AB = 452 volts
- BC = 464 volts
- AC = 455 volts

$$\text{Average Voltage} = \frac{452 + 464 + 455}{3}$$

$$= \frac{1371}{3} = 457$$

Determine maximum deviation from average voltage.

(AB) 457 – 452 = 5 volts

(BC) 464 – 457 = 7 volts

(AC) 457 – 455 = 2 volts

Maximum deviation is 7 volts.

Determine % voltage imbalance

$$\% \text{ Voltage Imbalance} = 100 \times \frac{7}{457} = 1.53\%$$

This amount of phase imbalance is satisfactory as it is below the maximum allowable 2%.

IMPORTANT: If the supply voltage phase imbalance is more than 2%, contact your local electric utility company immediately



SPECIAL PROCEDURES FOR 208-V OPERATION

⚠ WARNING

Make sure that the power supply to the unit is switched OFF before making any wiring changes. Electrical shock can cause personal injury or death.

1. Disconnect the orange transformer-primary lead from the contactor. See unit wiring label.
2. Remove the tape and cover from the terminal on the end of the red transformer-primary lead.
3. Save the cover.
4. Connect the red lead to the contactor terminal from which the orange lead was disconnected.
5. Using the cover removed from the red lead, insulate the loose terminal on the orange lead.
6. Wrap the cover with electrical tape so that the metal terminal cannot be seen.

Indoor blower motor speeds should be changed for 208-v operation. In the unit control box, change motor leads on the printed circuit board so that high speed is used for cooling and medium speed is used for heating. Do not change blower speed setting for 460-v rated units. Refer to Start-Up, Indoor Airflow and Airflow Adjustments section.

CONTROL VOLTAGE CONNECTIONS — Locate the room thermostat on an inside wall in the space to be conditioned, where it will not be subjected to either a cooling or heating source or direct exposure to sunlight. Mount the thermostat 4 to 5 ft above the floor.

Use no. 18 American Wire Gage (AWG) color-coded, insulated (35 C minimum) wires to make the control voltage connections between the thermostat and the unit. If the thermostat is located more than 100 ft from the unit (as measured along the control voltage wires), use no. 16 AWG color-coded, insulated (35 C minimum) wires.

A grommited, control voltage inlet hole is located in the panel adjacent to the control access panel. Run the low-voltage leads from the thermostat, through the inlet hole, and to the control voltage terminals through a hole in the bottom of the unit control box. Pass control voltage leads through wire ties located under unit control box. Connect the thermostat leads to the terminals as shown in Fig. 10.

HEAT ANTICIPATOR SETTING — The room thermostat heat anticipator must be adjusted properly to ensure proper heating performance. Set the heat anticipator, using an

ammeter between the W and R terminals to determine the exact required setting.

NOTE: For thermostat selection purposes, use 0.6 amp for the approximate required setting.

Failure to make a proper heat anticipator adjustment will result in improper operation, discomfort to the occupants of the conditioned space and inefficient energy utilization; however, the required setting may be changed slightly to provide a greater degree of comfort for a particular installation.

TRANSFORMER CIRCUIT PROTECTION — The unit transformer contains an auto. reset overcurrent protector for control circuit protection. If this device trips, it may reset without warning, starting the heating or cooling section of this product. Use caution when servicing; if overcurrent protector continues to trip, there is a problem in the low-voltage electrical circuit, such as an electrical short, ground or transformer overload. Disconnect power, correct the condition, and check for normal unit operation.

PRE-START-UP

⚠ WARNING

Failure to observe the following warnings could result in serious personal injury:

1. Follow recognized safety practices and wear protective goggles when checking or servicing refrigerant system.
2. Do not operate compressor or provide any electric power to unit unless compressor terminal cover is in place and secured.
3. Do not remove compressor terminal cover until all electrical sources are disconnected.
4. Relieve all pressure from system before touching or disturbing anything inside terminal box if refrigerant leak is suspected around compressor terminals.
5. Never attempt to repair soldered connection while refrigerant system is under pressure.
6. Do not use torch to remove any component. System contains oil and refrigerant under pressure. To remove a component, wear protective goggles and proceed as follows:
 - a. Shut off gas supply and *then* electrical power to unit.
 - b. Relieve all pressure from system using both high- and low-pressure ports.
 - c. Cut component connecting tubing with tubing cutter and remove component from unit.
 - d. Carefully unsweat remaining tubing stubs when necessary. Oil can ignite when exposed to torch flame.

Proceed as follows to inspect and prepare the unit for initial start-up:

1. Remove all access panels.
2. Read and follow instructions on all WARNING, CAUTION and INFORMATION labels attached to, or shipped with, unit.

Make the following inspections:

- a. Inspect for shipping and handling damages such as broken lines, loose parts, disconnected wires, etc.
- b. Inspect for oil at all refrigerant tubing connections and on unit base. Detecting oil generally indicates

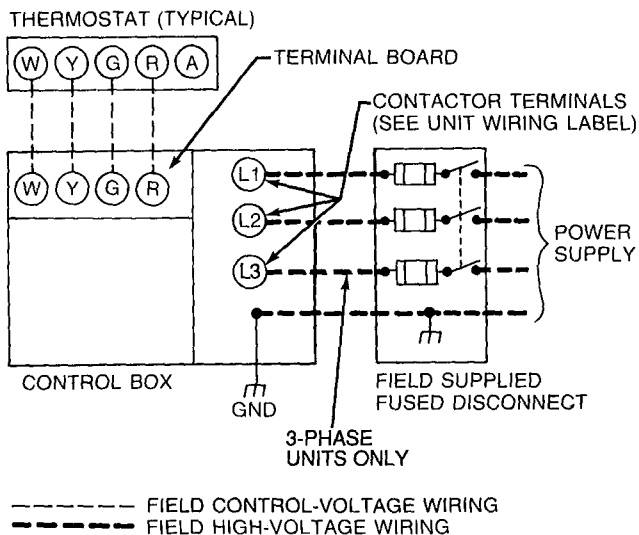

Fig. 10 — High- and Control-Voltage Connections

a refrigerant leak. Leak-test all refrigerant tubing connections using electronic leak detector, or liquid-soap solution. If a refrigerant leak is detected, see Start-Up, Check for Refrigerant Leaks section.

- c. Inspect all field- and factory-wiring connections. Be sure that connections are completed and tight.
 - d. Inspect coil fins. If damaged during shipping and handling, carefully straighten fins with a fin comb.
3. Verify the following conditions:

▲ WARNING

Do not purge gas supply into the combustion chamber. Do not use a match or other open flame to check for gas leaks. Failure to follow this warning could result in an explosion causing personal injury or death.

- a. Make sure that gas supply has been purged, and that all gas piping has been checked for leaks.
- b. Make sure that outdoor-fan blade is correctly positioned in fan orifice. *Blades should clear fan motor by no more than 1/4 inch.*
- c. Make sure that air filter(s) is in place.
- d. Make sure that condensate drain pan and trap are filled with water to ensure proper drainage.
- e. Make sure that all tools and miscellaneous loose parts have been removed.

START-UP

Check for Refrigerant Leaks — Proceed as follows to locate and repair a refrigerant leak and to charge the unit:

1. Locate leak and make sure that refrigerant system pressure has been relieved.
2. Repair leak following accepted practices.
NOTE: Install a filter drier whenever the system has been opened for repair.
3. Add a small charge of R-22 refrigerant vapor to system and leak-test unit.
4. Evacuate refrigerant system if additional leaks are not found.
5. Charge unit with R-22 refrigerant, using a volumetric-charging cylinder or accurate scale. *Refer to unit rating plate for required charge.* Be sure to add extra refrigerant to compensate for internal volume of filter drier.

Start-Up Heating Section and Make Adjustments

▲ CAUTION

Complete the required procedures given in Start-Up section before starting the unit.

Do not jumper any safety devices when operating the unit.

Make sure that burner orifices are aligned properly. Unstable operation may occur when the burner orifices in the manifold are misaligned.

NOTE: When installing a unit in extremely cold climate areas, a run-in period for the inducer motor is recommended. After the unit is installed, disconnect the red wire from terminal 2 at the ignition control (IGN) and jumper terminals R-W at the control voltage terminal board. The inducer motor should run but the burner will not ignite. Allow inducer motor to run for 4 to 5 hours. Reconnect red wire to terminal 2 at IGN and remove R-W jumper at the control voltage terminal board. Proceed as follows to complete heating section start-up.

Follow the lighting instructions on the heating section operation label (located inside the burner access door) to start the heating section.

When lighting the unit for the first time, perform the following:

If the gas supply pipe was not purged before connecting the unit, it will be full of air. It is recommended that the ground joint union be loosened, and the supply line be allowed to purge until the odor of gas is detected. Never purge gas lines into a combustion chamber. Immediately upon detection of gas odor, retighten the union. Allow 5 minutes to elapse, then light unit using the following steps.

CHECK HEATING CONTROL — Start and check the unit for proper heating control operation as follows: (See furnace lighting instructions located inside burner access panel.)

1. Place the room thermostat SYSTEM switch in the HEAT position and the fan switch in the AUTO. position.
2. Set the heating temperature control of the thermostat above room temperature.
3. Observe that after built-in time delays, the pilot automatically lights, the burners light and the blower motor starts.
4. Observe that the burners and pilot go out, and that after a built-in delay the blower motor stops when the heating control setting of the thermostat is satisfied.

NOTE: The 060-size 460-v models are equipped with a 3-phase blower motor. Check blower wheel for correct rotation as indicated by arrow on blower housing. If blower wheel rotates in opposite direction, reverse any 2 blower motor leads or any 2 line voltage leads. Recheck blower wheel rotation if necessary to reverse leads.

CHECK GAS INPUT — Check gas input and manifold pressure after unit start-up. (See Table 4.) If adjustment is required, proceed as follows.

The rated gas inputs shown in Table 4 are for altitudes from sea level up to 2000 ft above sea level. These inputs are based on natural gas with a heating value of 1050 Btu/ft³ at 0.65 specific gravity, or propane gas with a heating value of 2500 Btu/ft³ at 1.5 specific gravity. For elevations above 2000 ft, reduce input 4% for each 1000 ft above sea level. When the gas supply being used has a different heating value or specific gravity, refer to national and local codes, or contact your Distributor or Branch to determine the required orifice size.

▲ CAUTION

These units are designed to consume the rated gas inputs using the fixed orifices at specified manifold pressures as shown in Table 4. **DO NOT REDRILL THE ORIFICES UNDER ANY CIRCUMSTANCES.**

ADJUST GAS INPUT — The gas input to the unit is determined by measuring the gas flow at the meter or by measuring the manifold pressure. Measuring the gas flow at the meter is recommended for natural gas units. The manifold pressure must be measured to determine the input of propane gas units.

Measure Gas Flow (Natural Gas Units) — Minor adjustment to the gas flow can be made by changing the manifold pressure. The manifold pressure must be maintained between 3.2 and 3.8 in. wg. If larger adjustments are required, change main burner orifices following the recommendations of national and local codes.

Table 4 – Rated Gas Inputs

UNIT 48	NUMBER OF ORIFICES	GAS SUPPLY PRESSURE (in. wg)				MANIFOLD PRESSURE (in. wg)		NATURAL GAS		PROPANE*	
		Natural		Propane		Natural	Propane	Orifice Drill Size	Heating Input (Btuh)†	Orifice Drill Size	Heating Input (Btuh)†
		Min	Max	Min	Max						
NLT018,024,030	2	5.0	13.6	11.0	13.6	3.5	10.5	44	40,000	55	40,000
NLT036,042; NHT024; NMT030	3	5.0	13.6	11.0	13.6	3.5	10.5	44	60,000	55	60,000
NLT048,060; NMT036,042; NHT030	4	5.0	13.6	11.0	13.6	3.5	10.5	44	80,000	55	80,000
NET036,042	4	5.0	13.6	11.0	13.6	3.5	10.5	42	96,000	54	96,000
NMT048,060; NHT036,042	5	5.0	13.6	11.0	13.6	3.5	10.5	44	100,000	55	100,000
NHT048,060; NVT036,042	6	5.0	13.6	11.0	13.6	3.5	10.5	44	120,000	55	120,000
NVT048,060	6	5.0	13.6	11.0	13.6	3.5	10.5	42	144,000	54	144,000

*When a 48N unit is converted to propane, the unit must be modified. See kit instructions.

†Based on altitudes from sea level up to 2000 ft above sea level. For altitudes above 2000 ft, reduce input rating 4% for each 1000 ft above sea level. In Canada, from 2000 ft above sea level to 4500 ft above sea level, derate the unit 10%.

NOTE: All other appliances that use the same meter must be turned off when gas flow is measured at the meter.

Proceed as follows:

1. Turn off gas supply to unit.
2. Remove pipe plug on outlet of gas valve, then connect manometer at this point. Turn on gas to unit.
3. Record number of seconds for gas meter test dial to make one revolution.
4. Divide number of seconds in Step 3 into 3600 (number of seconds in one hour).
5. Multiply result of Step 4 by the number of cu ft shown for one revolution of test dial to obtain cu ft of gas flow per hour.
6. Multiply result of Step 5 by Btu heating value of gas to obtain total measured input in Btuh. Compare this value with heating input shown in Table 4. (Consult the local gas supplier if the heating value of gas is not known.)

Example: Assume that the size of test dial is one cu ft, one revolution takes 30 seconds, and the heating value of the gas is 1050 Btu/ft³. Proceed as follows:

1. 30 seconds to complete one revolution.
2. $3600 \div 30 = 120$.
3. $120 \times 1 = 120 \text{ ft}^3$ of gas flow/hr.
4. $120 \times 1050 = 126,000$ Btuh input.

If the desired gas input is 125,000 Btuh, only a minor change in the manifold pressure is required.

Observe manifold pressure and proceed as follows to adjust gas input:

1. Remove cover screw over regulator adjustment screw on gas valve.
2. Turn regulator adjustment screw clockwise to increase gas input, or turn regulator adjustment screw counterclockwise to decrease input. Manifold pressure must be between 3.2 and 3.8 in. wg.

▲ WARNING

Unsafe operation of the unit may result if manifold pressure is outside this range. Personal injury or unit damage may result.

3. Replace cover screw cap on gas valve.
4. Turn off gas supply to unit. Remove manometer from pressure tap. Replace pipe plug on gas valve. Turn on gas to unit. Check for leaks.

Measure Manifold Pressure (Propane Units) — The main burner orifices on a propane gas unit are sized for the unit rated input when the manifold pressure is 10.5 in. wg.

Proceed as follows to adjust gas input on a propane gas unit:

1. Turn off gas to unit.
2. Remove pipe plug on outlet of gas valve, then connect manometer at this point.
3. Turn on gas to unit.
4. Remove cover screw over regulator adjustment screw on gas valve.
5. Adjust regulator adjustment screw for a manifold pressure reading of 10.5 in. wg. Turn adjusting screw clockwise to increase manifold pressure, or turn adjusting screw counterclockwise to decrease manifold pressure.
6. Replace cover screw.
7. Turn off gas to unit. Remove manometer from pressure tap. Replace pipe plug on gas valve, then turn on gas to unit. Check for leaks.

CHECK BURNER FLAME — Observe the unit heating operation, and watch the burner flames through the observation port to see if they are light blue and soft in appearance, and that the flames are approximately the same for each burner. See Fig. 11.

BLOWER HEAT-RELAY OPERATION — Blower relay PC1 (see the unit wiring diagram) is located in the control box and adjusts to permit either longer or shorter “off” cycles. The “on” cycle is factory set for one minute on timing. The adjusting dial on the relay (see Fig. 12) is factory set at the minimum position to provide optimum performance for most installations. On unusual installations, the length of time the blower remains on may need to be increased. To increase blower operation time, rotate the adjusting dial counterclockwise. To decrease blower operation time, rotate dial clockwise.

AIRFLOW AND TEMPERATURE RISE — The heating section for each size unit is designed and approved for heating operation within the temperature-rise range stamped on the unit rating plate.

Table 5 shows the approved temperature-rise range for each unit, and the air delivery cfm at various temperature rises. The heating operation airflow must produce a temperature rise that falls within the approved range.

Refer to Indoor Airflow and Airflow Adjustments section to adjust heating airflow when required.

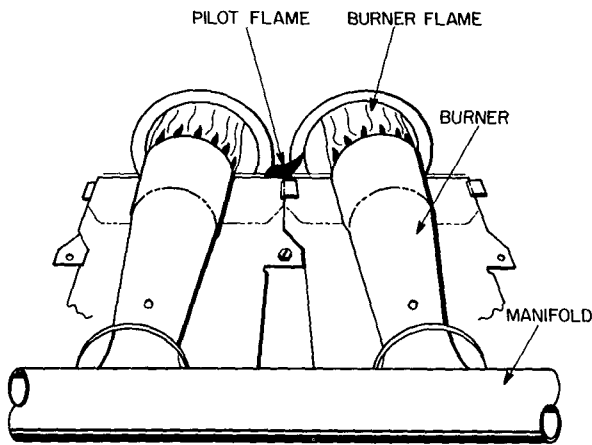

Fig. 11 – Monoport Burners

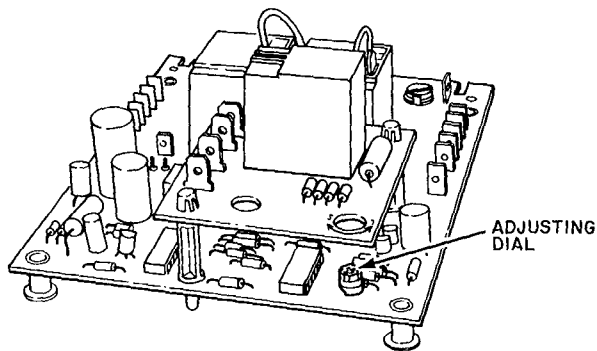

Fig. 12 – Blower Heat Relay

SAFETY CHECK OF LIMIT CONTROL — The control shuts off the gas supply and energizes the circulating-air blower motor if the furnace overheats.

The recommended method of checking this limit control is to gradually block off the return air after the furnace has been operating for a period of at least 5 minutes. As soon as the limit control functions, the return-air opening should be unblocked to permit normal air circulation. By using this method to check the limit control, it can be established that the limit is functioning properly and the furnace will “fail-safe” if there is a restricted circulating air supply or motor failure. If the limit control does not function during this test, the cause must be determined and corrected.

HEATING SEQUENCE OF OPERATION — See Fig. 13 for single-phase operation and Fig. 14 for 3-phase operation. Room thermostat calls for heat, closing circuit between R and W 24-v control circuit terminals. (Power to the R terminal is supplied through LS and ALS safety switches.) The PC2 inducer control board is energized through the normally closed set of contacts of pressure switches (CPS), which starts the inducer motor (IM). The IM comes up to speed, and the vacuum in the collector box increases, opening the normally closed and closing the normally open contacts of the pressure switch (PS), energizing the circuit to the ignition control (IGN) and the pilot valve (PV). If the flame sensor proves the presence of the pilot flame, the internal switching of the ignition control deenergizes the spark generator and energizes the main gas valve (MV) and the IFR2 electronic timer. Gas flows to the main burners and is ignited by the pilot flame. The PC1 electronic timer

will close the IFR2 relay 60 seconds after the burners are ignited and the blower motor (IFM) will start. When the thermostat is satisfied, the R and W circuit is opened and power is removed from the PC2 inducer control and the ignition module (IGN), which causes the MV to close instantly and the IM is deenergized. The electronic timer PC1 will keep the IFM running an additional 60 to 90 seconds. Then the blower stops and the unit is on standby until another call for heat.

NOTE: If the main limit switch opens due to the unit overheating, the IFM is turned on through the electronic board.

NOTE: When the unit is initially powered, IFR2 will close and run the IFM for the duration of the off-delay cycle (60 to 90 seconds).

If the pilot fails to light within a 120-second trial for ignition period from the initial call for heat, the IGN will go into a Retry mode after a period of approximately 5 minutes (following the 2-minute trial for ignition period). If the pilot again fails to light, IGN will go into Retry mode; this cycle will be repeated until the pilot light ignites. If the pilot flame has been established but then extinguishes, the IGN will immediately reset as if it were the initial call for heat. If this occurs more than 3 times, the IGN will lock out the system, and the diagnostic LED (located on the IGN) will flash. To reset, open the R-W thermostat circuit for 30 seconds and reclose. If the diagnostic LED glows constantly, replace control.

LIMIT SWITCHES — Normally closed limit switch LS completes the control circuit through the thermostat R circuit. See Fig. 13 and 14. Should the leaving-air temperature rise above the maximum allowable temperature, the limit switch opens and the R control circuit “breaks.” Any interruption in the R control circuit instantly closes the gas valve and stops gas flow to the burners and pilot. The IFM continues to run until the LS resets.

When the air temperature at the limit switch drops to the low-temperature setting of the limit switch, the switch closes and completes the R control circuit. The electric-spark ignition system cycles and the unit returns to normal heating operation.

BLOWER AUXILIARY LIMIT SWITCH — Blower auxiliary limit switch ALS1 is a temperature-actuated auto. reset switch and is connected in series with the limit switch LS. The function of the switch is to prevent abnormal blower compartment temperatures. The switch is mounted on the blower housing. When the temperature at the auxiliary switch reaches the maximum allowable temperature, the R control circuit “breaks”, closing the gas valve and stopping gas flow to the burners and pilot. The switch will automatically reset when the blower compartment temperature returns to normal. The IFM continues to run until ALS1 resets.

ROLLOUT AUXILIARY LIMIT SWITCH — Rollout auxiliary limit switch ALS2 is a temperature-actuated manual reset switch connected in series with limit switch LS and blower auxiliary limit switch ALS1. The function of the switch is to close the main gas valve in the event of flame rollout. The switch is located above the main burners. When the temperature at the auxiliary switch reaches the maximum allowable temperature, the R control circuit trips, closing the gas valve and stopping gas flow to the burners and pilot. To reset the switch, push in the red button. If the switch cycles again, shut down the unit and call for service. The IFM continues to run until ALS2 is reset.

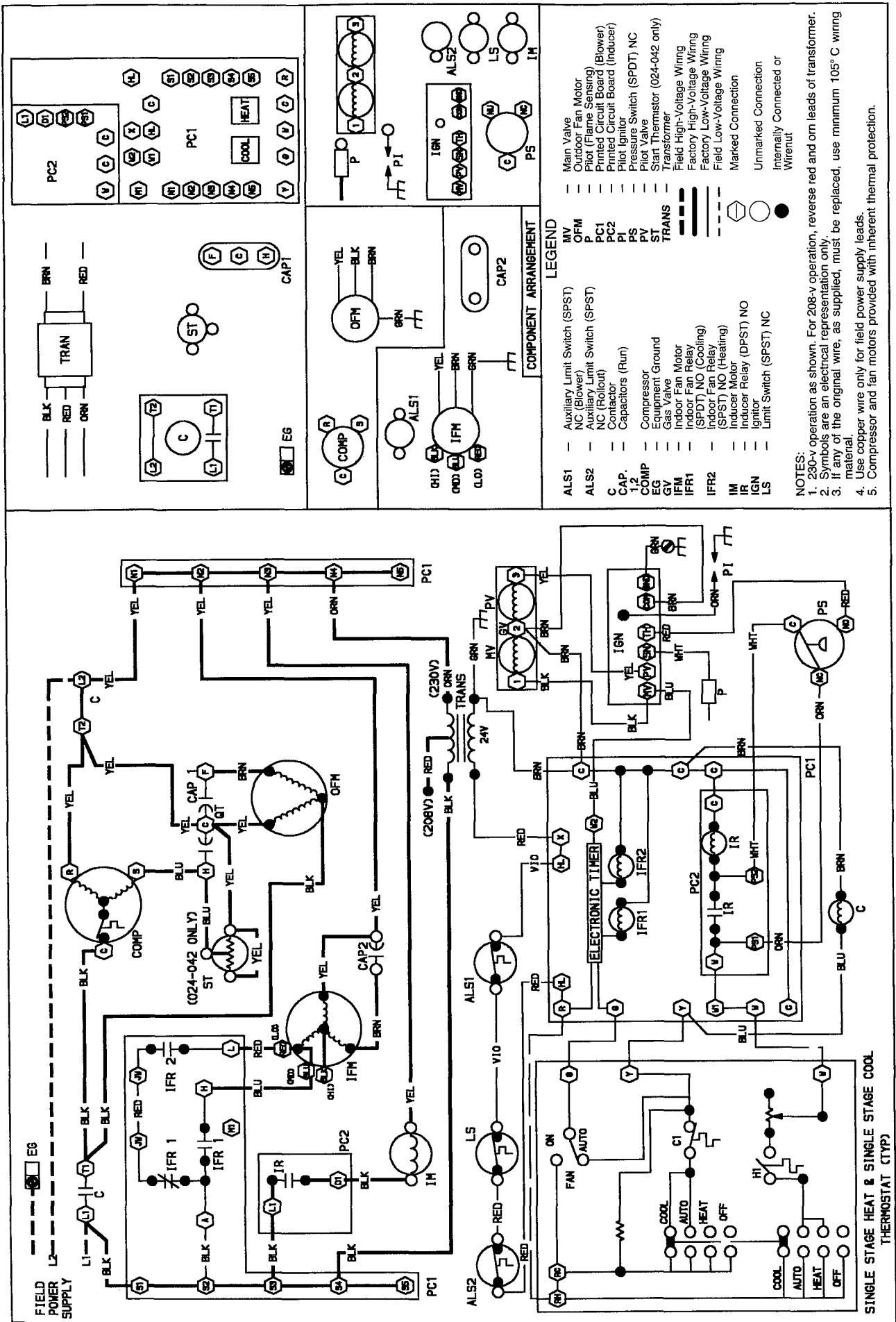

LEGEND

—	Auxiliary Limit Switch (SPST)	MV	Main Valve
—	NC (Blower)	OFM	Outdoor Fan Motor
—	Auxiliary Limit Switch (SPST)	P	Pilot (Flame Sensing)
—	NC (Rollout)	PC1	Printed Circuit Board (Blower)
—	Capacitor's (Run)	PC2	Printed Circuit Board (Inducer)
—	Compressor	PI	Pilot Ignitor
—	Equipment Ground	PS	Pressure Switch (SPDT) NC
—	Gas Valve	PV	Pilot Valve
—	Indoor Fan Motor	ST	Start Thermistor (024-042 only)
—	Indoor Fan Relay	TRANS	Transformer
—	(SPDT) NO (Cooling)	---	Field High-Voltage Wiring
—	Indoor Fan Relay	---	Factory High-Voltage Wiring
—	(SPST) NO (Heating)	---	Factory Low-Voltage Wiring
—	Inducer Motor	---	Field Low-Voltage Wiring
—	Ignitor	○	Marked Connection
—	Limit Switch (SPST) NO	○	Unmarked Connection
—	Limit Switch (SPST) NC	●	Internally Connected or Wirenut

- NOTES:**
- 230-v operation as shown. For 208-v operation, reverse red and orn leads of transformer.
 - Symbols are an electrical representation only.
 - If any of the original wire, as supplied, must be replaced, use minimum 105° C wiring material.
 - Use copper wire only for field power supply leads.
 - Compressor and fan motors provided with inherent thermal protection.

Fig. 13 — Typical Single-Phase Wiring Diagram

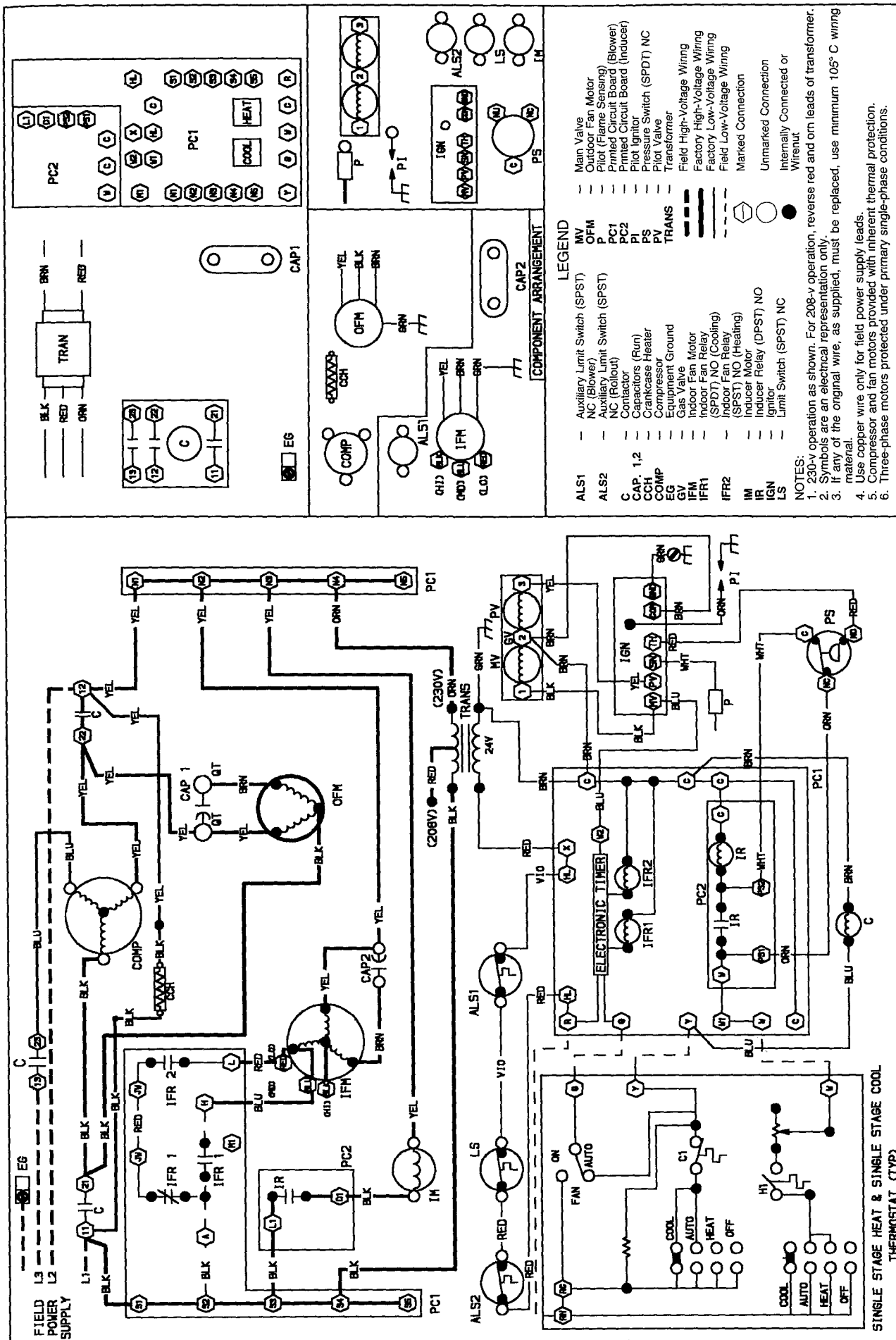

Fig. 14 — Typical 3-Phase Wiring Diagram

Start-Up Cooling Section and Make Adjustments

⚠ CAUTION

Complete the required procedures given in the Pre-Start-Up section before starting the unit.

Do not jumper any safety devices when operating the unit.

Do not operate the compressor when the outdoor temperature is below 55 F (unless accessory low-temperature kit is installed).

Do not rapid-cycle the compressor. Allow 5 minutes between "on" cycles to prevent compressor damage.

CHECKING COOLING CONTROL OPERATION — Start and check the unit for proper cooling control operation as follows:

1. Place room thermostat SYSTEM switch in OFF position. Observe that blower motor starts when FAN switch is placed in ON position and shuts down when FAN switch is placed in AUTO. position.
2. Place SYSTEM switch in COOL position and FAN switch in AUTO. position. Set cooling control below room temperature. Observe that compressor, condenser fan and evaporator blower motors start. Observe that cooling cycle shuts down when control setting is satisfied. The blower motor has an off delay of approximately one minute on shutdown.
3. When using an auto.-changeover room thermostat, place both SYSTEM and FAN switches in AUTO. positions. Observe that unit operates in heating mode when temperature control is set to "call for heating" (above room temperature) and operates in cooling mode when temperature control is set to "call for cooling" (below room temperature).

CHECKING AND ADJUSTING REFRIGERANT CHARGE — The refrigerant system is fully charged with R-22 refrigerant, tested and factory-sealed.

NOTE: Adjustment of the refrigerant charge is not required unless the unit is suspected of not having the proper R-22 charge. For all applications, the correct R-22 charge for the best performance is the charge that results in a suction gas superheat of 5 F at the compressor inlet when the unit is operating at the ARI rating conditions of 95 F dry-bulb (db) outdoor and 80 F db/67 F wet-bulb (wb) indoor.

A superheat charging label is attached to the outside of the compressor access door. The label includes a "Superheat Charging Table" and a "Required Suction-Tube Temperature (F)" chart.

An accurate superheat thermocouple- or thermistor-type thermometer, a sling psychrometer and a gage manifold are required when using the superheat charging method for evaluating the unit charge. *Do not use mercury or small dial-type thermometers because they are not adequate for this type of measurement.*

⚠ CAUTION

When evaluating the refrigerant charge, an indicated adjustment to the specified factory charge must always be very minimal. If a substantial adjustment is indicated, an abnormal condition exists somewhere in the cooling system, such as insufficient airflow across either coil or both coils.

Proceed as follows:

1. Remove caps from low- and high-pressure service fittings.

2. Using hoses with valve core depressors, attach low- and high-pressure gage hoses to low- and high-pressure service fittings, respectively.
3. Start unit in cooling mode and let unit run until system pressures stabilize.
4. Measure and record the following.
 - a. Outdoor ambient-air temperature (F db).
 - b. Evaporator inlet-air temperature (F wb).
 - c. Suction-tube temperature (F) at low-side service fitting.
 - d. Suction (low-side) pressure (psig).
5. Using "Superheat Charging Table," compare outdoor-air temperature (F db) with evaporator inlet-air temperature (F wb) to determine desired system operating superheat temperature. See Table 6.
6. Using "Required Suction-Tube (F)" table, compare desired superheat temperature with suction (low-side) operating pressure (psig) to determine proper suction-tube temperature. See Table 7.
7. Compare actual suction-tube temperature with proper suction-tube temperature. Using a tolerance of ± 3 F, add refrigerant if actual temperature is more than 3 F higher than proper suction-tube temperature, or remove refrigerant if actual temperature is more than 3 F lower than required suction-tube temperature.

NOTE: If the problem causing the inaccurate readings is a refrigerant leak, refer to Start-Up, Check for Refrigerant Leaks section.

INDOOR AIRFLOW AND AIRFLOW ADJUSTMENTS

⚠ CAUTION

For cooling operation, the recommended airflow is 350 to 450 cfm per each 12,000 Btuh of rated cooling capacity. For heating operation, the airflow must produce a temperature rise that falls within the range stamped on the unit rating plate.

Direct-drive blower motors are factory connected to deliver the proper heating and cooling airflows at normal external static pressures (medium speed cooling, low speed heating for 230-v units) and high speed cooling (units with 460-v have medium speed cooling and high speed heating).

For 208-v operation on 208/230-v rated direct drive units, interchange motor leads to high speed for cooling and medium speed for heating operation.

Table 5 shows the temperature rise at various airflow rates. Tables 8 and 9 show both heating and cooling airflows at various external static pressures. Refer to these tables to determine the airflow for the system being installed.

NOTE: Be sure that all supply- and return-air grilles are open, free from obstructions and adjusted properly.

⚠ WARNING

Disconnect electrical power to the unit before changing blower speed. (Be sure to turn off gas supply *before* disconnecting electrical power.) Electrical shock can cause personal injury or death.

⚠ CAUTION

Do not change the blower-motor lead connections on 460-v units from the factory setting. Damage to unit may result.

Table 5 – Air Delivery (Cfm) at Indicated Temperature Rise and Rated Heating Input

NOMINAL SIZE	HEATING INPUT (Btuh)	UNIT TEMPERATURE RISE (°F)													
		20	25	30	35	40	45	50	55	60	65	70	75	80	
NLT018,024,030	40,000	—	—	987	846	740	658	592	538	493	—	—	—	—	
NHT024; NMT030	60,000	—	—	—	—	—	—	987	888	808	740	683	634	592	
NLT036,042	60,000	—	—	1481	1269	1111	987	888	808	740	—	—	—	—	
NHT030; NMT036,042	80,000	—	—	—	—	—	—	1316	1185	1077	987	911	846	790	
NLT048	80,000	—	2370	1975	1693	1481	1316	1185	1077	—	—	—	—	—	
NLT060	80,000	2962	2370	1975	1693	1481	1316	1185	—	—	—	—	—	—	
NET036,042	96,000	—	—	—	—	1777	1580	1422	1292	1185	1096	1015	—	—	
NHT036,042; NMT048	100,000	—	—	—	2116	1851	1646	1481	1346	1234	1139	—	—	—	
NMT060	100,000	—	—	2469	2116	1851	1646	1481	1346	1234	—	—	—	—	
NVT036,042; NHT048	120,000	—	—	—	—	—	—	1777	1616	1481	1367	1269	1185	1111	
NHT060	120,000	—	—	—	2539	2222	1975	1777	1616	1481	1367	—	—	—	
NVT048,060	144,000	—	—	—	—	—	2370	2133	1939	1777	1641	1523	1422	—	

NOTE: Dashed areas of the table do not fall in the approved temperature rise range of the unit

Table 6 – Superheat Charging Table*

OUTDOOR TEMP (F)	INDOOR COIL ENTERING AIR TEMP (F wb)													
	50	52	54	56	58	60	62	64	66	68	70	72	74	76
55	9	12	14	17	20	23	26	29	32	35	37	40	42	45
60	7	10	12	15	18	21	24	27	30	33	35	38	40	43
65	—	6	10	13	16	19	21	24	27	30	33	36	38	41
70	—	—	7	10	13	16	19	21	24	27	30	33	36	39
75	—	—	—	6	9	12	15	18	21	24	28	31	34	37
80	—	—	—	—	5	8	12	15	18	21	25	28	31	35
85	—	—	—	—	—	—	8	11	15	19	22	26	30	33
90	—	—	—	—	—	—	5	9	13	16	21	24	27	31
95	—	—	—	—	—	—	—	6	10	14	18	22	25	29
100	—	—	—	—	—	—	—	—	8	12	15	20	23	27
105	—	—	—	—	—	—	—	—	5	9	13	17	22	26
110	—	—	—	—	—	—	—	—	—	6	11	15	20	25
115	—	—	—	—	—	—	—	—	—	—	8	14	18	23

*Superheat at suction service valve.

NOTE: Do not attempt to charge system under these conditions; refrigerant slugging may occur

Table 7 – Required Suction-Tube Temperature (F)*

SUPERHEAT TEMP (F)	SUCTION PRESSURE AT SERVICE PORT (psig)									
	61.5	64.2	67.1	70.0	73.0	76.0	79.2	82.4	85.7	
0	35	37	39	41	43	45	47	49	51	
2	37	39	41	43	45	47	49	51	53	
4	39	41	43	45	47	49	51	53	55	
6	41	43	45	47	49	51	53	55	57	
8	43	45	47	49	51	53	55	57	59	
10	45	47	49	51	53	55	57	59	61	
12	47	49	51	53	55	57	59	61	63	
14	49	51	53	55	57	59	61	63	65	
16	51	53	55	57	59	61	63	65	67	
18	53	55	57	59	61	63	65	67	69	
20	55	57	59	61	63	65	67	69	71	
22	57	59	61	63	65	67	69	71	73	
24	59	61	63	65	67	69	71	73	75	
26	61	63	65	67	69	71	73	75	77	
28	63	65	67	69	71	73	75	77	79	
30	65	67	69	71	73	75	77	79	81	
32	67	69	71	73	75	77	79	81	83	
34	69	71	73	75	77	79	81	83	85	
36	71	73	75	77	79	81	83	85	87	
38	73	75	77	79	81	83	85	87	89	
40	75	77	79	81	83	85	87	89	91	

*Temperature at suction service valve

**Table 8 – Dry Coil Air Delivery (Cfm)*
at Indicated External Static Pressure and Voltage
– Horizontal Discharge (Without Filter)**

48 V-PH-HZ	MOTOR SPEED	in. wg	208 V						230 V or 460 V					
			0.0	0.1	0.2	0.3	0.4	0.5	0.0	0.1	0.2	0.3	0.4	0.5
NLT018, NLT024, NHT024 208/230-1-60	Low†, Med**	Watts	451	427	407	383	365	348	501	477	457	433	415	398
		Cfm	1185	1129	1088	1026	979	922	1256	1195	1148	1081	1031	971
	Hi	Watts	511	483	464	440	420	402	561	533	514	490	470	452
		Cfm	1370	1291	1221	1142	1063	1003	1442	1359	1285	1202	1119	1056
NLT030, NMT030 208/230-1-60	Low†, Med**	Watts	519	507	492	477	455	431	569	557	542	527	505	481
		Cfm	1184	1163	1150	1134	1105	1064	1248	1226	1211	1194	1164	1120
	Hi	Watts	620	602	581	559	532	493	670	652	631	609	582	543
		Cfm	1443	1414	1376	1329	1279	1197	1519	1489	1449	1399	1347	1261
NHT030, NLT036 NMT036, NLT042 NMT042 208/230-1-60 208/230-3-60, 460-3-60††	Low†, Med**	Watts	560	544	527	505	482	461	610	593	575	500	524	494
		Cfm	1515	1452	1389	1308	1227	1105	1597	1530	1464	1378	1293	1164
	Hi	Watts	670	650	631	602	573	542	720	701	680	653	625	594
		Cfm	1765	1705	1621	1521	1383	1254	1857	1795	1708	1603	1457	1321
NET036, 042 208/230-1-60 208/230-3-60 460-3-60††	Low†, Med**	Watts	873	847	814	785	758	734	987	945	911	877	850	809
		Cfm	1717	1690	1645	1597	1550	1496	1979	1922	1859	1802	1734	1667
	Hi	Watts	1075	1030	995	960	930	900	1121	1087	1046	1017	981	952
		Cfm	2119	2062	1995	1913	1863	1793	2135	2066	1998	1931	1858	1795
NHT036, NVT036 NHT042, NVT042 208/230-1-60 208/230-3-60 460-3-60††	Low†, Med**	Watts	740	700	660	615	580	540	755	725	680	650	610	575
		Cfm	1913	1820	1736	1645	1544	1428	1976	1909	1806	1714	1603	1495
	Hi	Watts	790	760	720	690	650	610	850	820	780	750	715	675
		Cfm	2032	1942	1844	1759	1636	1514	2086	1983	1883	1782	1665	1545
NLT048, NMT048 NHT048 208/230-1-60 208/230-3-60 460-3-60††	Low†, Med**	Watts	770	730	690	650	610	575	810	765	730	695	655	610
		Cfm	1945	1880	1796	1708	1611	1508	2061	1970	1892	1813	1704	1580
	Hi	Watts	850	810	770	730	690	655	890	855	820	780	750	715
		Cfm	2138	2045	1943	1846	1738	1624	2178	2081	1941	1869	1769	1650
NVT048 208/230-1-60 208/230-3-60 460-3-60††	Low†, Med**	Watts	985	950	915	890	860	820	1095	1055	1010	975	935	890
		Cfm	1931	1901	1862	1813	1768	1703	2183	2125	2071	2005	1931	1854
	Hi	Watts	1220	1165	1130	1080	1035	995	1300	1265	1220	1180	1120	1085
		Cfm	2376	2311	2244	2170	2083	2003	2511	2431	2359	2271	2168	2087
NLT060, NMT060 NHT060, NVT060 208/230-1-60 208/230-3-60 460-3-60††	Low†, Med**	Watts	1125	1055	1015	980	940	905	1205	1125	1095	1060	1030	990
		Cfm	2184	2125	2063	2000	1938	1880	2285	2225	2163	2106	2045	1980
	Hi	Watts	1220	1175	1125	1080	1040	1005	1300	1250	1210	1165	1130	1085
		Cfm	2380	2307	2262	2165	2095	2024	2487	2412	2335	2260	2179	2110

*Air delivery values are without air filter and are for dry coil. See Table 10 for wet coil pressure drop. Deduct field-supplied air filter pressure drop and wet coil pressure drop to obtain external static pressure available for ducting.

†Factory blower-motor speed setting for heating operation.

**Factory blower-motor speed setting for cooling operation.

††Do not change blower speed settings for units with 460-v (high speed only).

NOTE: Do not operate the unit at a cooling airflow that is less than 350 cfm per each 12,000 Btuh of rated cooling capacity. Evaporator coil icing may occur at airflows below this point. Water blow-off may occur at airflows above 450 cfm per 12,000 Btuh of rated cooling capacity

The heating and/or cooling airflow of 208/230-v direct-drive blower motors can be changed by changing the lead connections of the blower motor. The motor leads are color-coded as follows:

- black* = high speed
- blue* = medium speed
- red* = low speed

NOTE: For all 208/230-v direct-drive units, the red motor lead connected to the heat relay (L) on PC1 blower control determines the heating speed and resulting airflow, and the blue motor lead connected to the cooling relay (H) on PC1 blower control determines the cooling speed and resulting airflow. See the unit wiring label.

To change the heating and/or cooling speed of a direct-drive motor, connect the appropriate color-coded lead at blower motor connector to speed-tap desired. (See unit wiring label.)

When installing a 208- or 230-v direct-drive unit that is factory connected for heating and cooling speeds that are not the same, and the same speed for both heating and cooling is required for a particular application, disconnect red lead at terminal L of heat relay and connect to terminal MI on PC1 blower control. Connect a field-supplied jumper between terminal L on heat relay and terminal H of cooling relay. Connect blue lead at blower motor to appropriate speed tap.

**Table 9 – Dry Coil Air Delivery (Cfm)*
at Indicated External Static Pressure and Voltage
– Vertical Discharge (Without Filter)**

48 V-PH-HZ	MOTOR SPEED	in. wg	208 V						230 V or 460 V					
			0.0	0.1	0.2	0.3	0.4	0.5	0.0	0.1	0.2	0.3	0.4	0.5
NLT018, NLT024 NHT024 208/230-1-60	Low†, Med**	Watts	451	417	397	373	355	338	491	467	447	423	405	388
		Cfm	1138	1102	1045	996	942	889	1196	1161	1101	1050	993	932
	Hi	Watts	491	463	454	420	400	382	541	513	494	470	450	432
		Cfm	1308	1234	1162	1084	1020	951	1379	1301	1225	1143	1075	1002
NLT030, NMT030 208/230-1-60	Low†, Med**	Watts	509	497	482	467	445	421	559	547	532	517	495	471
		Cfm	1155	1138	1120	1104	1073	1031	1218	1200	1182	1165	1132	1088
	Hi	Watts	600	582	561	539	512	473	650	632	611	589	562	523
		Cfm	1411	1362	1326	1249	1195	1133	1493	1457	1412	1358	1274	1218
NHT030, NLT036 NMT036, NLT042 NMT042 208/230-1-60 208/230-3-60 460-3-60††	Low†, Med**	Watts	522	504	485	663	440	422	600	573	555	523	491	470
		Cfm	1494	1430	1358	1273	1174	1058	1574	1507	1431	1341	1237	1115
	Hi	Watts	651	631	610	575	540	517	695	680	658	624	590	563
		Cfm	1683	1615	1536	1440	1274	1153	1763	1700	1619	1492	1343	1215
NET036, NET042 208/230-1-60 208/230-1-60 460-3-60††	Low†, Med**	Watts	833	792	765	725	700	650	880	850	810	790	745	710
		Cfm	1653	1611	1569	1518	1473	1373	1805	1748	1692	1650	1582	1475
	Hi	Watts	945	915	890	865	805	770	1005	965	935	900	865	820
		Cfm	1895	1839	1803	1740	1029	1532	1971	1899	1830	1762	1673	1568
NHT036, NVT036 NHT042, NVT042 208/230-1-60 208/230-3-60 460-3-60††	Low†, Med**	Watts	680	645	610	580	545	510	705	670	640	595	570	535
		Cfm	1797	1709	1620	1547	1448	1315	1855	1707	1684	1574	1498	1361
	Hi	Watts	750	715	680	650	615	585	795	765	735	700	670	640
		Cfm	1885	1779	1704	1608	1507	1404	1906	1821	1722	1623	1533	1410
NLT048, NHT048 NMT048 208/230-1-60 208/230-3-60 460-3-60††	Low†, Med**	Watts	710	680	650	600	570	520	740	705	665	635	600	560
		Cfm	1833	1768	1700	1599	1505	1390	1918	1849	1752	1670	1561	1442
	Hi	Watts	785	750	720	685	650	610	835	805	770	735	705	670
		Cfm	1957	1873	1786	1699	1598	1495	1997	1907	1817	1713	1618	1506
NVT048 208/230-1-60 208/230-3-60 460-3-60††	Low†, Med**	Watts	965	915	875	840	800	770	1025	985	935	900	870	830
		Cfm	1878	1821	1767	1716	1654	1584	2060	1996	1921	1075	1030	995
	Hi	Watts	1130	1097	1026	985	970	915	1200	1165	1120	1075	1030	995
		Cfm	2199	2134	2095	1960	2060	1799	2280	2213	2168	2019	1921	1856
NLT060, NMT060 NHT060, NVT060 208/230-1-60 208/230-3-60 460-3-60††	Low†, Med**	Watts	1095	1025	985	950	910	875	1175	1095	1065	1030	1000	960
		Cfm	2125	2165	2005	1950	1887	1830	2225	2170	2110	2050	1987	1930
	Hi	Watts	1190	1145	1095	1050	1010	975	1280	1230	1190	1140	1110	1065
		Cfm	2325	2255	2187	2120	2050	1975	2437	2365	2390	2220	2145	2075

*Air delivery values are without air filter and are for dry coil. See Table 10 for wet coil pressure drop. Deduct field-supplied air filter pressure drop and wet coil pressure drop to obtain external static pressure available for ducting.

†Factory blower-motor speed setting for heating operation.

**Factory blower-motor speed setting for cooling operation.

††Do not change blower speed settings for units with 460-v (high speed only).

NOTE: Do not operate the unit at a cooling airflow that is less than 350 cfm per each 12,000 Btuh of rated cooling capacity. Evaporator coil icing may occur at airflows below this point. Water blow-off may occur at airflows above 450 cfm per 12,000 Btuh of rated cooling capacity.

UNIT CONTROLS — All compressors have the following internal-protection controls:

1. *High-Pressure Relief Valve* — This valve opens when the pressure differential between the low and high side becomes excessive.
2. *Compressor Overload* — This overload interrupts power to the compressor when either the current or internal temperature become excessive, and automatically resets when the internal temperature drops to a safe level.

This overload may require up to 60 minutes (or longer) to reset; therefore, if the internal overload is suspected of being open, disconnect the electrical power to the unit and

check the circuit through the overload with an ohmmeter or continuity tester.

COOLING SEQUENCE OF OPERATION

NOTE: Although the actual unit wiring may vary slightly from that shown in Fig. 13 and 14, the sequence of operation will not be affected.

With the room thermostat SYSTEM switch in the COOL position and the FAN switch in the AUTO. position, the cooling sequence of operation is as follows:

When the room temperature rises to a point that is slightly above the cooling control setting of the thermostat, the thermostat completes the circuit between thermostat terminal R

to terminals Y and G. These completed circuits through the thermostat connect contactor coil C (through unit wire Y) and relay coil IFR1 (through unit wire G) across the 24-v secondary of transformer TRAN.

The normally open contacts of energized contactor C close and complete the circuit through compressor motor COMP and condenser fan motor OFM. Both motors start instantly.

The set of normally open contacts of energized relay IFR1 close and complete the circuit through evaporator blower motor IFM. The blower motor starts instantly.

NOTE: The cooling cycle remains "on" until the room temperature drops to point that is slightly below the cooling control setting of the room thermostat. At this point, the thermostat "breaks" the circuit between thermostat terminal R to terminals Y and G. These open circuits de-energize contactor coil C and relay coil IFR1. The condenser and compressor motors stop. After a 45-second delay, the blower motor stops. The unit is in a "standby" condition, waiting for the next "call for cooling" from the room thermostat.

Table 10 – Wet Coil Pressure Drop

MODEL	AIRFLOW (cfm)	WET COIL PD (in. wg)
018,024	600	.038
	700	.044
	800	.052
	900	.062
030	900	.042
	1000	.050
	1200	.064
036,042	1000	.038
	1200	.050
	1400	.064
	1600	.080
048	1400	.050
	1600	.060
	1800	.072
060	1700	.100
	1900	.120
	2100	.140
	2300	.160

MAINTENANCE

To ensure continuing high performance, and to minimize the possibility of premature equipment failure, periodic maintenance must be performed on this equipment. This combination heating/cooling unit should be inspected at least once each year by a qualified service person. To troubleshoot heating or cooling of units, refer to Tables 11 and 12.

NOTE TO EQUIPMENT OWNER: Consult your local Dealer about the availability of a maintenance contract.

⚠ WARNING

The ability to properly perform maintenance on this equipment requires certain expertise, mechanical skills, tools and equipment. If you do not possess these, do not attempt to perform any maintenance on this equipment, other than those procedures recommended in the User's Manual. FAILURE TO HEED THIS WARNING COULD RESULT IN SERIOUS PERSONAL INJURY AND POSSIBLE DAMAGE TO THIS EQUIPMENT.

The minimum maintenance requirements for this equipment are as follows:

1. Inspect air filter(s) each month. Clean or replace when necessary.
2. Inspect cooling coil, drain pan and condensate drain each cooling season for cleanliness. Clean when necessary.
3. Inspect blower motor and wheel for cleanliness and check lubrication each heating and cooling season. Clean and lubricate (if required) when necessary.
4. Check electrical connections for tightness and controls for proper operation each heating and cooling season. Service when necessary.
5. Check and inspect heating section before each heating season. Clean and adjust when necessary.
6. Check and clean vent screen if needed.

⚠ WARNING

Failure to follow these warnings could result in serious personal injury:

1. Turn off gas supply, *then* turn off electrical power to the unit before performing any maintenance or service on the unit.
2. Use extreme caution when removing panels and parts. As with any mechanical equipment, personal injury can result from sharp edges, etc.
3. Never place anything combustible either on, or in contact with, the unit.
4. Should overheating occur, or the gas supply fail to shut off, shut off the external main manual gas valve to the unit, *then* shut off the electrical supply.

Table 11 – Heating Troubleshooting Chart

SYMPTOM	CAUSE	REMEDY
IGN locked out.	LED flashing	Look for problems external to the ignitor module.
	LED glowing continuously	Replace IGN control.
Pilot will not light.	No spark at electrode	Check air gap between electrode tip and pilot target Gap should be as shown in Fig. 15. Readjust as necessary.
		Clean moisture or dirt accumulation on electrode ceramic with cloth.
		Cracked ceramic — replace pilot electrode assembly
		Check for loose or broken wiring at and between electronic control head and electrode. Replace wire or tighten connection as necessary.
		Check fuses or circuit breaker to ensure voltage to unit.
		Check for 24 v between TH and COM. If you read 24 v and above steps have been completed, replace electronic ignition control.
	Spark shorting out to main burner	Realign electrode tip away from main burner but maintain spark gap to pilot burner. See Fig. 15.
No gas at pilot burner	Clean pilot orifice.	
	Check inlet pressure to gas valve. Recommended operating pressure 7-in. wg natural gas, 11-in. wg LP gas; 0.5 psig (13.6-in. wg) max. pressure	
	Check for 24 v between terminals PV and COM. If you read 24 v and above steps have been completed, replace gas valve.	
Burners will not ignite.	Water in gas line	Drain — install water trap.
	No power to furnace	Check power supply, fuses, wiring or circuit breaker.
	No 24-v power supply to control circuit	Check transformer — replace if necessary.
	Miswired or loose connections	Check all wiring and wirenut connections.
	Dirty pilot — yellow flame	Clean pilot orifice.
	Pilot burning improperly — sharp blue flame	Replace pilot.
	Burned-out heat anticipator in thermostat	Replace thermostat.
	No gas at main burners	1. Check for 24 v between terminals MV and COM on control head. If you read 24 v, replace gas valve portion of control head/gas valve assembly. 2. If 24 v is not present, check flame sensor for cracked ceramic insulator or shorted sensor cable.
Broken thermostat wire	Run continuity check to locate break.	
Inadequate heating.	Dirty air filter	Clean or replace filter as necessary.
	Gas input to furnace too low	Check gas pressure at manifold. Clock gas meter for input. If too low, increase manifold pressure, or replace with correct orifices.
	Unit undersized for application	Replace with proper unit — or add additional unit
	Restricted airflow	Clean or replace filter — or remove any restriction.
	Blower speed too low	Use faster speed tap
		Check temperature rise.
	Limit switch cycles main burners	Dirty air filters — clean or replace. Registers closed, restricted ductwork — open or remove restriction. Check temperature rise. Check heat anticipator setting on thermostat — readjust.
Poor flame characteristics.	Incomplete combustion results in: Aldehyde odors, CO, sooting flame — floating flame	Check all screws around flue outlets and burner compartment — tighten.
		LACK OF COMBUSTION AIR.
		Cracked heat exchanger — replace.
		Overfired furnace — reduce input, or change orifices.
		Check vent for restriction — clean as required
	Check orifice for burner alignment.	

GR — Ground
LP — Liquid Propane

Table 12 – Cooling Troubleshooting Chart

SYMPTOM	CAUSE	REMEDY
Compressor and condenser fan will not start.	Power failure	Call power company
	Fuse blown or circuit breaker tripped	Replace fuse or reset circuit breaker.
	Defective thermostat, contactor, transformer or control relay	Replace component.
	Insufficient line voltage	Determine cause and correct.
	Incorrect or faulty wiring	Check wiring diagram and rewire correctly.
	Thermostat setting too high	Lower thermostat setting below room temperature
Compressor will not start but condenser fan runs.	Faulty wiring or loose connections in compressor circuit	Check wiring and repair or replace.
	Compressor motor burner out, seized or internal overload open	Determine cause. Replace compressor.
	Defective run/start capacitor, overload, start relay	Determine cause and replace.
	One leg of 3-phase power dead	Replace fuse or reset circuit breaker. Determine cause.
Compressor cycles (other than normally satisfying thermostat).	Refrigerant overcharge or undercharge	Blow refrigerant, evacuate system and recharge to nameplate.
	Defective compressor	Replace and determine cause
	Insufficient line voltage	Determine cause and correct
	Blocked condenser	Determine cause and correct.
	Defective run/start capacitor, overload or start relay	Determine cause and replace.
	Defective thermostat	Replace thermostat.
	Faulty condenser fan motor or capacitor	Replace.
	Restriction in refrigerant system	Locate restriction and remove.
Compressor operates continuously.	Dirty air filter	Replace filter.
	Unit undersized for load	Decrease load or increase unit size.
	Thermostat set too low	Reset thermostat.
	Low refrigerant charge	Locate leak, repair and recharge.
	Leaking valves in compressor	Replace compressor.
	Air in system	Blow refrigerant, evacuate system and recharge.
	Condenser coil dirty or restricted	Clean coil or remove restriction.
Excessive head pressure.	Dirty air filter	Replace filter.
	Dirty condenser coil	Clean coil.
	Refrigerant overcharged	Purge excess refrigerant.
	Air in system	Blow refrigerant, evacuate system and recharge.
	Condenser air restricted or air short-cycling	Determine cause and correct.
Head pressure too low.	Low refrigerant charge	Check for leaks, repair and recharge.
	Compressor valves leaking	Replace compressor
	Restriction in liquid tube	Remove restriction.
Excessive suction pressure.	High heat load	Check for source and eliminate.
	Compressor valves leaking	Replace compressor
	Refrigerant overcharged	Purge excess refrigerant.
Suction pressure too low.	Dirty air filter	Replace filter
	Low refrigerant charge	Check for leaks, repair and recharge.
	Metering device or low side restricted	Remove source of restriction.
	Insufficient evaporator airflow	Increase air quantity. Check filter — replace if necessary.
	Temperature too low in conditioned area	Reset thermostat.
	Outdoor ambient below 55 F	Install low-ambient kit.
	Field-installed filter-drier restricted	Replace.

Air Filter

⚠ CAUTION

Never operate the unit without a suitable air filter in the return-air duct system. Always replace the filter with the same dimensional size and type as originally installed. See Table 1 for recommended filter sizes.

Inspect air filter(s) at least once each month and replace (disposable-type) or clean (cleanable-type) at least twice during each heating and cooling season or whenever the filter(s) becomes clogged with dust and lint.

Replace filters with the same dimensional size and type as originally provided, when necessary.

Unit Top Removal

⚠ CAUTION

Condenser fan and motor are fastened to the unit top. When removing the top, use extreme care to not pull the fan motor leads loose.

NOTE: When performing maintenance or service procedures that require removal of the unit top, be sure to perform *all* of the routine maintenance procedures that require top removal, including: inspection of the heat exchanger area, coil inspection and cleaning, and condensate drain pan inspection and cleaning.

Only qualified service personnel should perform maintenance and service procedures that require unit top removal. Refer to the following top removal procedures:

1. Turn off gas supply, *then* turn off electric power to unit.
2. Remove all screws that secure unit top, including screws around 4 sides and those on top that screw into internal divider panels. Save all screws.
3. Tape all side panels at each seam near unit top. Use tape strips that are at least 5-in. long to prevent sides from falling when top is removed.
4. Lift top from unit carefully. Set top on edge and make sure that top is supported by unit side that is opposite duct (or plenum) side. *Use extreme care to prevent damage to the fan blades, motor and insulation.*
5. Carefully replace and secure unit top to unit, using screws removed in Step 2, when maintenance and/or service procedures are completed. (Be sure to use original screws that have rubber washers to seal out water when securing top to internal divider panels.)

Evaporator Blower and Motor

NOTE: Motors without oilers are prelubricated. Do not attempt to lubricate these motors.

For longer life, operating economy and continuing efficiency, clean accumulated dirt and grease from the blower wheel and motor annually.

Lubricate the motor every 5 years if the motor is used intermittently (thermostat FAN switch in AUTO. position),

or every 2 years if the motor is used continuously (thermostat FAN switch in ON position).

⚠ WARNING

Turn off the gas supply, *then* disconnect and tag electrical power to the unit before cleaning and lubricating the blower motor and wheel. Failure to adhere to this warning could cause personal injury or death.

To clean and lubricate the blower motor and wheel for direct-drive models:

1. Remove and disassemble blower assembly as follows:
 - a. Remove blower access door.
 - b. Disconnect blower-motor leads from their termination points at motor. Disconnect yellow lead from control box at capacitor. Disconnect auxiliary limit-switch leads at switch.
 - c. Remove blower assembly from unit. Be careful not to tear insulation in blower compartment.
 - d. Ensure proper reassembly by marking blower wheel and motor in relation to blower housing before disassembly.
 - e. Loosen setscrew(s) that secures wheel to motor shaft, remove screws that secure motor mount brackets to housing and slide motor and motor mount out of housing.
2. Lubricate motor as follows:
 - a. Thoroughly clean all accumulations of dirt or grease from motor housing.
 - b. Remove dust caps or plugs from oil ports located at each end of motor.
 - c. Use a good grade of SAE 20 nondetergent motor oil and put one teaspoon (5 cc, $\frac{3}{16}$ oz., or 16 to 25 drops) in each oil port.
 - d. Allow time for oil to be absorbed by each bearing, then wipe excess oil from motor housing.
 - e. Replace dust caps or plugs in oil ports.
3. Remove and clean blower wheel as follows:
 - a. Ensure proper reassembly by marking wheel orientation and cutoff plate location.
 - b. Remove screws holding cut-off plate, and remove plate from housing.
 - c. Lift wheel from housing. When handling and/or cleaning blower wheel, be sure not to disturb balance weights (clips) on blower wheel vanes.
 - d. Remove caked-on dirt from wheel and housing with a brush. Remove lint and/or dirt accumulations from wheel and housing with vacuum cleaner, using soft brush attachment. Remove grease and oil with mild solvent.
 - e. Reassemble wheel and cut-off plate into housing.
 - f. Reassemble motor into housing. Be sure setscrews are tightened on motor shaft flats and not on round part of shaft.

Heating Section — Ensure dependable and efficient heating operation by inspecting the heating section before each heating season, and cleaning when necessary.

Proceed as follows to inspect and clean heating section:

1. Turn off gas and power to unit.
2. Remove burner access door.
3. Disconnect 2 wires from inducer motor.
4. Remove complete inducer assembly from unit.
5. Remove screws that secure collector box to heat exchanger, exposing flue openings.
6. Remove flue choke.
7. Clean heat exchanger cells using field-provided small wire brush, steel spring cable, reversible electric drill and vacuum cleaner.

To assemble wire brush and steel spring cable:

NOTE: The items below can be purchased at a local hardware store.

- a. Use 4 ft of ¼ in. diameter high-grade steel spring cable (commonly known as drain cleanout or Roto-Rooter cable).
- b. Use ¼-in. diameter wire brush (commonly known as 25-caliber rifle cleaning brush).
- c. Insert twisted wire end of brush into end of spring cable; crimp tight with crimping tool or strike with ball-peen hammer. *Tightness is very important.*
- d. Remove metal sleeve from wire brush to allow proper brush action.

To clean each heat exchanger cell:

- a. Attach variable-speed reversible drill to end of spring cable (end opposite brush).
- b. Insert brush end of cable into upper opening of cell and slowly rotate with drill. *Do not* force cable. Gradually insert at least 3 ft of cable into 2 upper passes of cell.
- c. Work cable in and out of cell 3 or 4 times to obtain sufficient cleaning. *Do not* pull cable with great force. Reverse drill and gradually work cable out.
- d. Remove burner assembly.
- e. Insert brush end of cable in lower opening of cell and proceed to clean in same manner.
- f. Repeat above procedures until each cell in unit is cleaned.
- g. Using vacuum cleaner, remove residue from each cell.
- h. Using vacuum cleaner with soft brush attachment, clean burner assembly.
- i. Reinstall burner assembly.
8. After cleaning, check sealant and gaskets to make sure that they have not been damaged. If new sealants or gaskets are needed, contact your Distributor.
9. Reinstall flue choke. Be sure all screws are in and are tight.
10. Clean and replace flue collector assembly, making sure all screws are secure.
11. Replace inducer assembly.
12. Reconnect the 2 wires to inducer motor.
13. Replace burner access door.
14. Turn on power and gas.
15. Set thermostat and check unit for proper operation.

Pilot — Inspect the pilot and clean (when necessary) at the beginning of each heating season. Remove the accumulation of soot and carbon from the pilot. The pilot flame must be high enough for proper contact with the flame sensor. Pilot flame must also come in contact with the pilot hood (target) for proper operation. If the pilot flame appears too hard (lifting and blowing) or too soft (unstable), check inlet gas pressure for proper value. (See Table 4.) The spark electrode must be located so the spark travels through a combustible mixture of gas; if necessary, readjust the electrode as shown in Fig. 15; be certain to maintain the ⅛-in. spark gap.

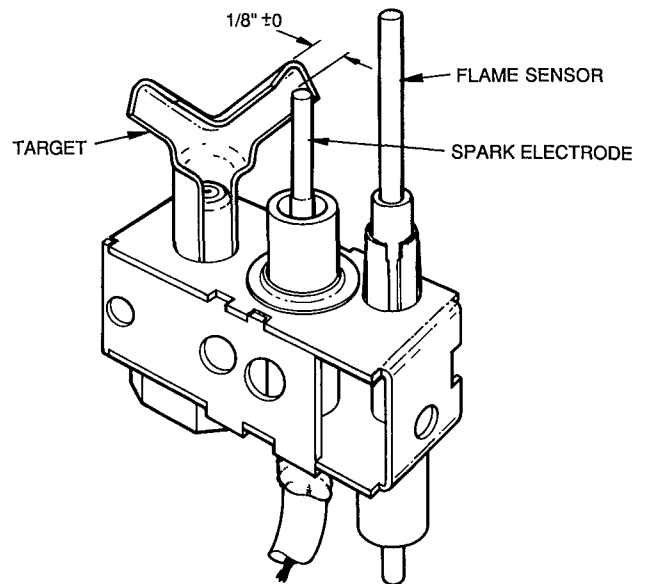

Fig. 15 — Position of Electrode to Pilot

Condenser Coil, Evaporator Coil and Condensate Drain Pan — Inspect the condenser coil, evaporator coil and condensate drain pan at least once each year. Proper inspection and cleaning requires the removal of the unit top. See Unit Top Removal section.

The coils are easily cleaned when dry; therefore, inspect and clean the coils either before or after each cooling season. Remove all obstructions, including weeds and shrubs, that interfere with the airflow, through the condenser coil. Straighten bent fins with a fin comb. If coated with dirt or lint, clean the coils with a vacuum cleaner, using the soft brush attachment. Be careful not to bend the fins. If coated with oil or grease, clean the coils with a mild detergent-and-water solution. Rinse coils with clear water, using a garden hose. Be careful not to splash water on motors, insulation, wiring or air filter(s). For best results, spray condenser coil fins from inside to outside the unit. On units with an outer and inner condenser coil, be sure to clean between the coils. Be sure to flush all dirt and debris from the unit base.

Inspect the drain pan and condensate drain line when inspecting the coils. Clean the drain pan and condensate drain by removing all foreign matter from the pan. Flush the pan and drain tube with clear water. Do not splash water on the insulation, motor, wiring or air filter(s). If the drain tube is restricted, clear it with a “plumbers snake” or similar probe device.

Condenser Fan

⚠ CAUTION

Keep the condenser fan free from all obstructions to ensure proper cooling operation. Never place articles on top of the unit. Damage to unit may result.

Remove control and compressor access panels. Inspect the fan blades for cracks or bends each year. *Make sure that blades clear the motor by no more than 1/4 inch.* If the blade assembly has slipped down the motor shaft, adjust the fan position on the motor shaft by loosening the set-screw(s), then moving the blade assembly up. Be sure that the setscrew(s) is on the flat(s) of the motor shaft before tightening.

Electrical Controls and Wiring — Inspect and check the electrical controls and wiring annually. *Be sure to turn off the gas supply, and then the electrical power to the unit.*

Remove the control, blower and compressor compartment access panels to locate all the electrical controls and wiring. Check all electrical connections for tightness. Tighten all screw connections. If any smoky or burned connections are noticed, disassemble the connection, clean all the parts, restrip the wire end and reassemble the connection properly and securely.

After inspecting the electrical controls and wiring, replace all the panels. Start the unit, and observe at least one complete heating cycle and one complete cooling cycle to ensure proper operation. If discrepancies are observed in either or both operating cycles, or if a suspected malfunction has occurred, check each electrical component with the proper electrical instrumentation. Refer to the unit wiring label when making these checkouts.

NOTE: Refer to the heating and/or cooling sequence of operation in this publication as an aid in determining proper control operation.

Refrigerant Circuit — Inspect all refrigerant tubing connections and the unit base for oil accumulations annually. Detecting oil generally indicates a refrigerant leak.

If oil is detected or if low cooling performance is suspected, leak-test all refrigerant tubing using an electronic leak-detector, or liquid-soap solution. If a refrigerant leak is detected, refer to Start-Up, Check for Refrigerant Leaks section.

If no refrigerant leaks are found and low cooling performance is suspected, refer to Checking and Adjusting Refrigerant Charge section.

Gas Input — The gas input does not require checking unless improper heating performance is suspected. If a problem exists, refer to Start-Up section.

Evaporator Airflow — The heating and/or cooling airflow does not require checking unless improper performance is suspected. *If a problem exists, be sure that all supply- and return-air grilles are open and free from obstructions, and that the air filter is clean.* When necessary, refer to Indoor Airflow and Airflow Adjustment section to check the system airflow.

Metering Device Servicing — See Fig. 16 for metering device components. The piston has a refrigerant metering orifice through it. The retainer forms a sealing surface for liquid line flare connection. To check, clean or replace piston:

1. Shut off power to unit.
2. Remove refrigerant from unit using approved refrigerant removal methods from both high- and low-service port connections.
3. Remove liquid line flare connections from metering device.
4. Note position of arrow on metering device body with respect to unit.
5. Pull retainer out of body. Be careful not to scratch flare sealing surface. If retainer does not pull out easily, carefully use locking pliers to remove retainer. Replace scratched or damaged retainer.
6. Slide piston out by inserting a small, soft wire through metering hole (18-gage thermostat wire). See that metering hole, sealing surface around piston cones and fluted portion of piston are not damaged.
7. Use the chart on the unit access panel to determine proper arrangement and size of piston. See Table 13 for piston sizes.
8. Clean piston refrigerant-metering orifice.
9. Replace retainer O-ring (part no. 99CC501052).

Liquid Line Strainer — The liquid line strainer (to protect metering device) is made of wire mesh and located in the liquid line on inlet side. Strainer is pressed into the line. Remove strainer by threading a no. 10 sheet-metal screw into strainer and pulling the screw with pliers.

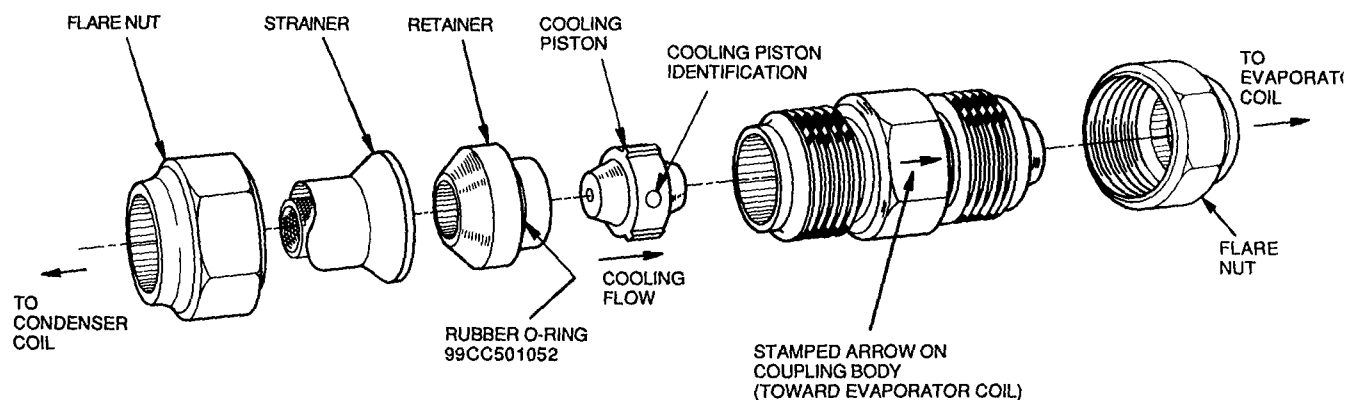

Fig. 16 — Metering Device Components

Table 13 – Piston Sizes

UNIT 48	PISTON IDENTIFICATION
NLT018	59
NLT024	63
NHT024	63
NLT030	73
NMT030	73
NHT030	73
NET036	80
NLT036	80
NMT036	80
NHT036	80
NVT036	80
NET042	82
NLT042	82
NMT042	82
NHT042	84
NVT042	84
NLT048	86
NMT048	86
NHT048	86
NVT048	86
NLT060	101
NMT060	101
NHT060	101
NVT060	101

Copyright 1991 Carrier Corporation

Manufacturer reserves the right to discontinue, or change at any time, specifications or designs without notice and without incurring obligations.

Book | 1 | 4
Tab | 1a | 1a

PC 111

Catalog No. 564-920

Printed in U.S.A

Form 48NT-20SI

Pg 28

11-91

Replaces: 48NT-19SI