

ZDP486NDPSS (Natural Gas) ZDP486LDPSS (Liquid Propane) GE Monogram® 48" Dual-Fuel Professional Range with 6 Burners and Griddle

Dimensions and Installation Information (in inches)

Professional ranges offer a number of choices in size and cooktop configurations.

All Professional Ranges are factory set for natural or liquid propane gas. The correct model should be ordered for the installation situation.

Note: Conversion kits are included with the range if the wrong gas type was ordered. High Altitude kit, WB28K10553 for operation above 3,000 feet (for Natural and LP gas models), is also available. The kits must be installed by a qualified service technician at additional cost.

Installation Information

Before installing, consult installation instructions packed with product or online at Monogram.com for current dimensional data.

A 48" or 54" wide professional vent hood with a minimum 1200 CFM is recommended for installation over this range.

Advance Planning

Refer to dimensional drawings for appropriate placement and necessary clearances when planning the installation.

- Working areas adjacent to the range should have 18" minimum clearance between countertop and cabinet bottom.
- Clearance between range and side wall or combustible material must be at least 12" on each side.
- Installation must conform with local codes. In the absence of local codes, the range must comply with the National Fuel Gas Code, ANSI Z223.1-1990.

⚠ WARNING:

Installations without a hood require 48" minimum to combustibles. A custom hood installation with exposed horizontal combustible surfaces must have an Auto-On feature. Refer to hood installation instructions for specific hood clearances.

The surface of the entire back wall above the range and below the hood must be covered with a non-combustible material such as metal, ceramic tile, brick, marble or other stone.

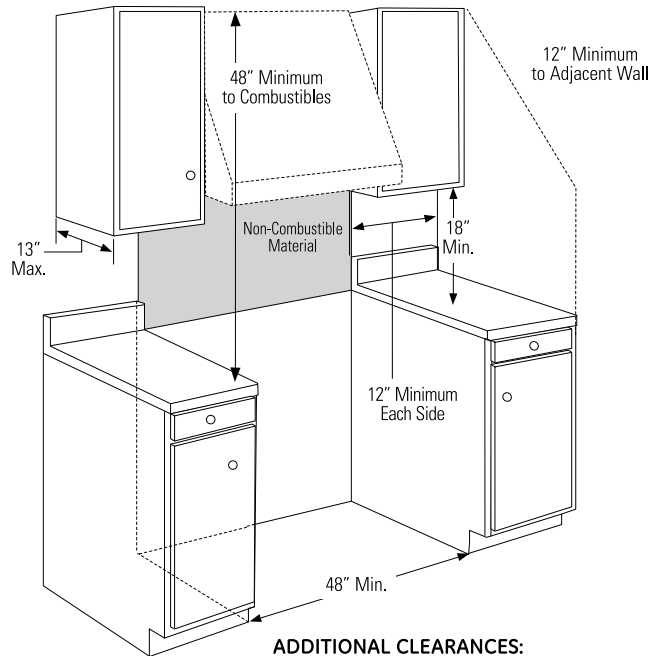
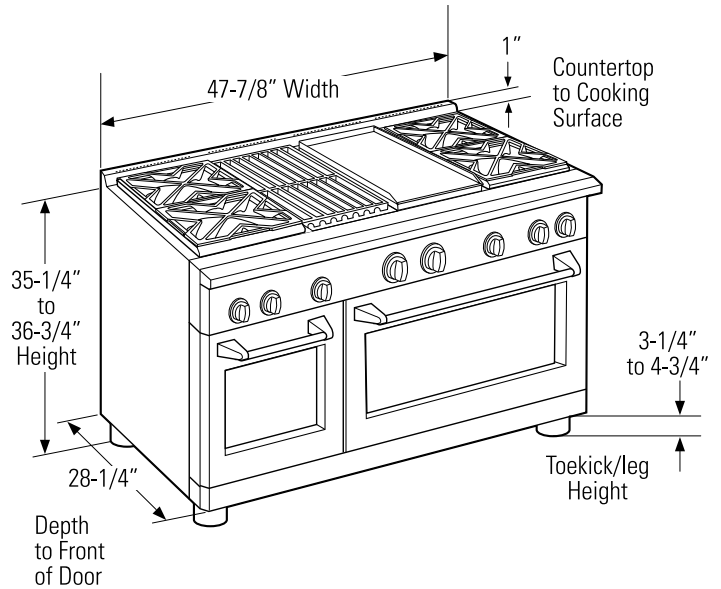

ADDITIONAL CLEARANCES:

Allow 12" minimum clearance to an adjacent wall on each side.

Working areas adjacent to the rangetop should have 18" minimum clearance between countertop and the bottom of the wall cabinet.

For answers to your Monogram,® GE Profile™ or GE® appliance questions, visit our website at ge.com or call GE Answer Center® service, 800.626.2000.



imagination at work



Listed by Underwriters Laboratories



ZDP486NDPSS (Natural Gas) ZDP486LDPSS (Liquid Propane)

GE Monogram® 48" Dual-Fuel Professional Range with 6 Burners and Griddle

Dimensions and Installation Information (in inches)

Electrical Requirements

Ranges must be supplied with 208/240V, 60Hz, and connected to an individual, properly grounded branch circuit protected by a circuit breaker or time-delay fuse. Install a 50-amp circuit for 48" ranges. The receptacle must be a NEMA 14-50R device to accept the four-prong plug on the range.

Universal Utility Locations

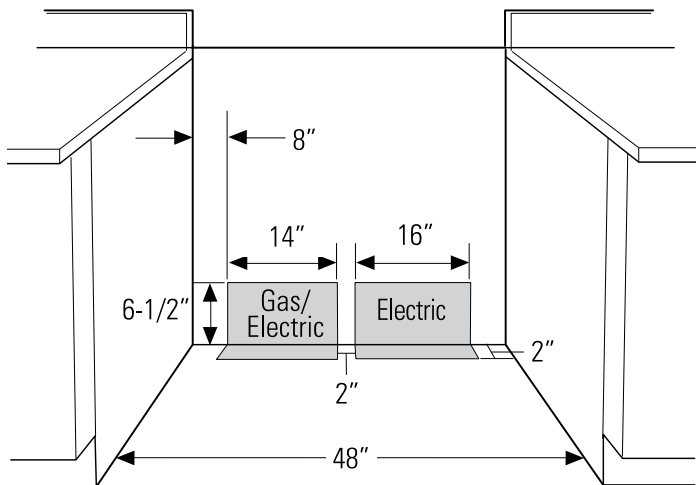

Locate gas and electric as shown

Gas Supply

- The natural gas models are designed to operate at 5" water column pressure. For proper operation, the pressure of the natural gas supplied to the regulator must be between 7" and 13" water column.
- The LP models are designed to operate at 10" water column pressure. For proper operation, the pressure of the LP gas supplied to the regulator must be between 11" and 13" water column.

For answers to your Monogram®, GE Profile™ or GE® appliance questions, visit our website at ge.com or call GE Answer Center® service, 800.626.2000.

Optional Backsplash Accessories

The range requires a 12" minimum clearance to a vertical combustible surface at the rear. A backsplash is required for installations with less than 12" clearance. The following backsplash accessories are available, or a custom, non-combustible backsplash can be used

Order one with a 48"-wide range backsplash

ZX12B48PSS–12" backsplash

ZXADJB48PSS–30"-36" adjustable-height backsplash with warming shelf

Side View with a Backsplash

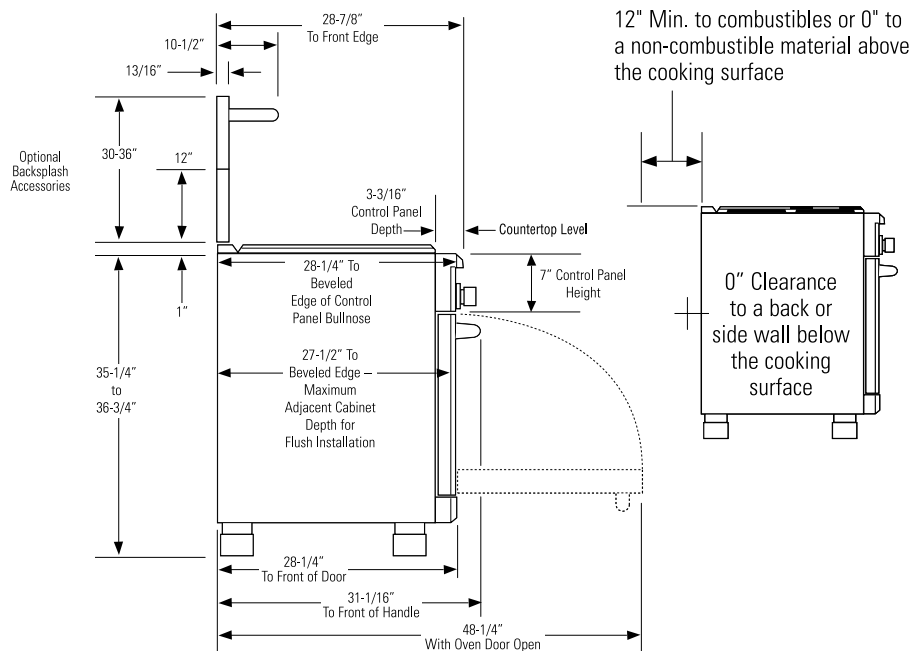

imagination at work



Listed by Underwriters Laboratories



ZDP486NDPSS (Natural Gas)

ZDP486LDPSS (Liquid Propane)

GE Monogram® 48" Dual-Fuel Professional Range with 6 Burners and Griddle

Features and Benefits

- Authentic Professional appearance with premium-grade, 304 stainless steel with smoothly finished edges, large electronic control knobs and heavy duty handles
- Sealed, dual-flame stacked burners deliver a full spectrum of heat settings, from an ultra-low 140°F simmer to an intense 18,000 BTUs*
- Monogram Professional oven system combines European, Reverse-Air convection technology and six heating elements in each oven to provide superb baking results
- Heavy-duty, full-extension racks glide smoothly in and out on stainless steel ball bearings for easy access, and are designed to remain in the oven during the self-clean cycle
- LED task lights below the bullnose provide a functional and theatrical touch
- Stainless steel and aluminum-clad griddle offers 18,000 BTUs* of cooking power, allowing fast and consistent heating across the entire cooking surface
- Reversible burner grates are flat on one side and uniquely contoured on the other to accommodate round-bottom woks
- A caterer's oven is uniquely sized to accommodate three full-size sheet trays
- Everyday oven is just the right size for 9" x 13" casserole dishes
- Model ZDP486NDPSS - Natural Gas*
- Model ZDP486LDPSS - Liquid Propane

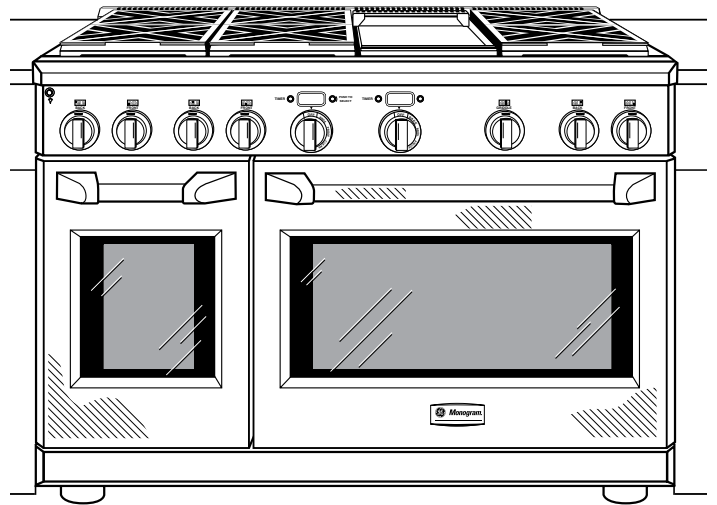

For answers to your Monogram,® GE Profile™ or GE® appliance questions, visit our website at ge.com or call GE Answer Center® service, 800.626.2000.



imagination at work