



**Trailer Parts Manual
and
Stationary* Parts Manual
REEL AUGGIE MIXERS**

Models 3115

***Serial Number A0029 and After**

Table of Contents

Abbreviations	2
Using This Service Parts Listing	3
Front End Parts	4
Sprockets, Chains and Tighteners	6
Stationary Motor Mount Parts	8
Reel and Auger Parts	10
Bucket Guard Parts - Trailer Type Units	12
Top Grid Parts - Stationary Type Units	13
Hydraulic Door Parts - Trailer Type	14
Door Parts - Stationary Type	15
Electric Door Parts - Stationary Type (Optional)	16
Slide Tray Parts - Trailer Type (Optional)	17
Adjustable Slide Tray Parts - Optional Trailer Type	18
Selector Valve Parts - Trailer Type (Optional)	19
Undercarriage Parts	20
Scale Parts	22
PTO Driveline - 540 RPM - 6 Spline - 1-3/8" Yoke	24
Jackstand Parts	25
HAY MAXX System (Stationary Only)	26
Repair Liner Parts	27
Decals	28
Paint	28
Optional Kits	28
Hardware Part Number Listing	29
Part Number Index	31

Catalog Part Number 06050 Unit Serial Number _____

[Operator's Instruction Manual for this unit: 006047](#)

Abbreviations

Assy	Assembly
A/R	As Required
B	Bolt
Brg	Bearing
BSN	Before Serial Number
Btm	Bottom
C-Bolt	Carriage Bolt
Ctr	Cotter
CV	Constant Velocity
Deg	Degree
Dia	Diameter
ea	Each
eq or Equiv	Equivalent
Fln	Flanged Lock Nut
Fw	Flat Washer
Ga	Gauge
Gr or Grd	Grade
Hd	Head
Hfw	Heavy Flat Washer
Hyd	Hydraulic
ID	Inside Diameter
Ill or Illus	Illustration
Ind	Indicator
Jn	Jam Nut
Kw	Keyway
LH	Left Hand
Ln	Lock Nut
Lw	Lock Washer
Mtg Hrd	Mounting Hardware
NC	National Coarse
NF	National Fine
NLA	No Longer Available
NPT	National Pipe Thread
OD	Outside Diameter
Pc(s)	Piece(s)
PD	Pitch Diameter
PTO	Power Takeoff (shaft)
Qty	Quantity
RH	Right Hand
SN	Serial Number
SHCS	Socket Head Cap Screw
Spk, or Spkt or Sprkt	Sprocket
Sq	Square
SS	Stainless Steel
SSB	Stainless Steel Bolt
St	Straight
Std	Standard
STS	Self Tapping Screw
UASN	Used After Serial Number
UBSN	Used Before Serial Number
W	With
W/O	With Out

Using This Service Parts Listing

This listing uses a number indentation system to specify the parts of an assembly. Any number which is indented to the right, indicates that it is a component of the item to the upper left. Example:

Part no	Qty	Description
102-AAA	#	Assembly A
102-BBB	#	Sub-Assembly B
(Component of A)		
140-xxx	#	Sub-Component of B
140-xxx	#	Sub-Component of B
102-CCC	#	Sub-Assembly C
(Component of A)		
etc.		

Using this system, the subassemblies and their components are included if an **Assembly** is ordered. Similarly, the components of a subassemblies are included if a subassembly is ordered.

The quantity (Qty) associated with an assembly, represents the number of times an assembly could be shown in the drawing. The subassembly quantity however, is the number of times a subassembly is used to build one assembly. Similarly, the component quantity refers to the number of times a given component is found in one subassembly.

MODEL AND SERIAL NUMBER INFORMATION is located near the front left hand corner (Fig. A). The model number, serial number and part number should be known when asking service personnel for parts.

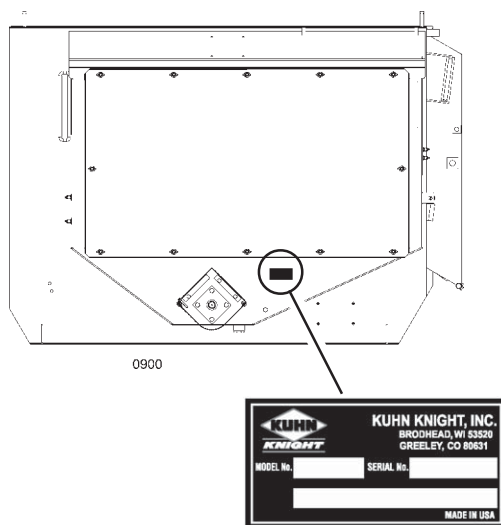

Figure A

The serial number may consist of a number, or a number with a letter prefix. When referring to serial number breaks in the text of this manual, a serial number with a prefix will have been manufactured after a serial number without a prefix (A001 made after 0123). Likewise, a higher prefix letter would indicate manufacture after a lower prefix letter (B001 made after A123). Therefore, if the text refers to units manufactured after serial number B123, this would include "B" series numbers greater than 123, and all numbers with a higher letter prefix.

If you cannot find the part you need, be as descriptive as possible when placing an order:

Sprockets: give the bore size, number of teeth, and size of keyway.

Roller chain: give the size of chain (stamped on the side of each link) and number of links.

Shafting: give the diameter, length, and quantity and size of keyways.

Hardware is generally not included with parts. If you need any hardware, check the size, the length, and the grade (Fig. B), then check the hardware list in this manual for the part numbers.

All hex head bolts are grade 5, and nuts are grade 5 unless otherwise stated.

The hardware listing also includes zerks, cotter pins, set screws, and roller chain links.

The illustrations in this manual are meant to be used only as a guide for identifying parts and locating their relative positions.

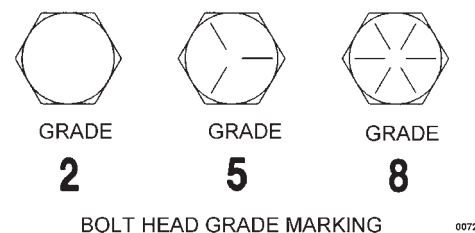

BOLT HEAD GRADE MARKING

0072

Fig. B

Front End Parts

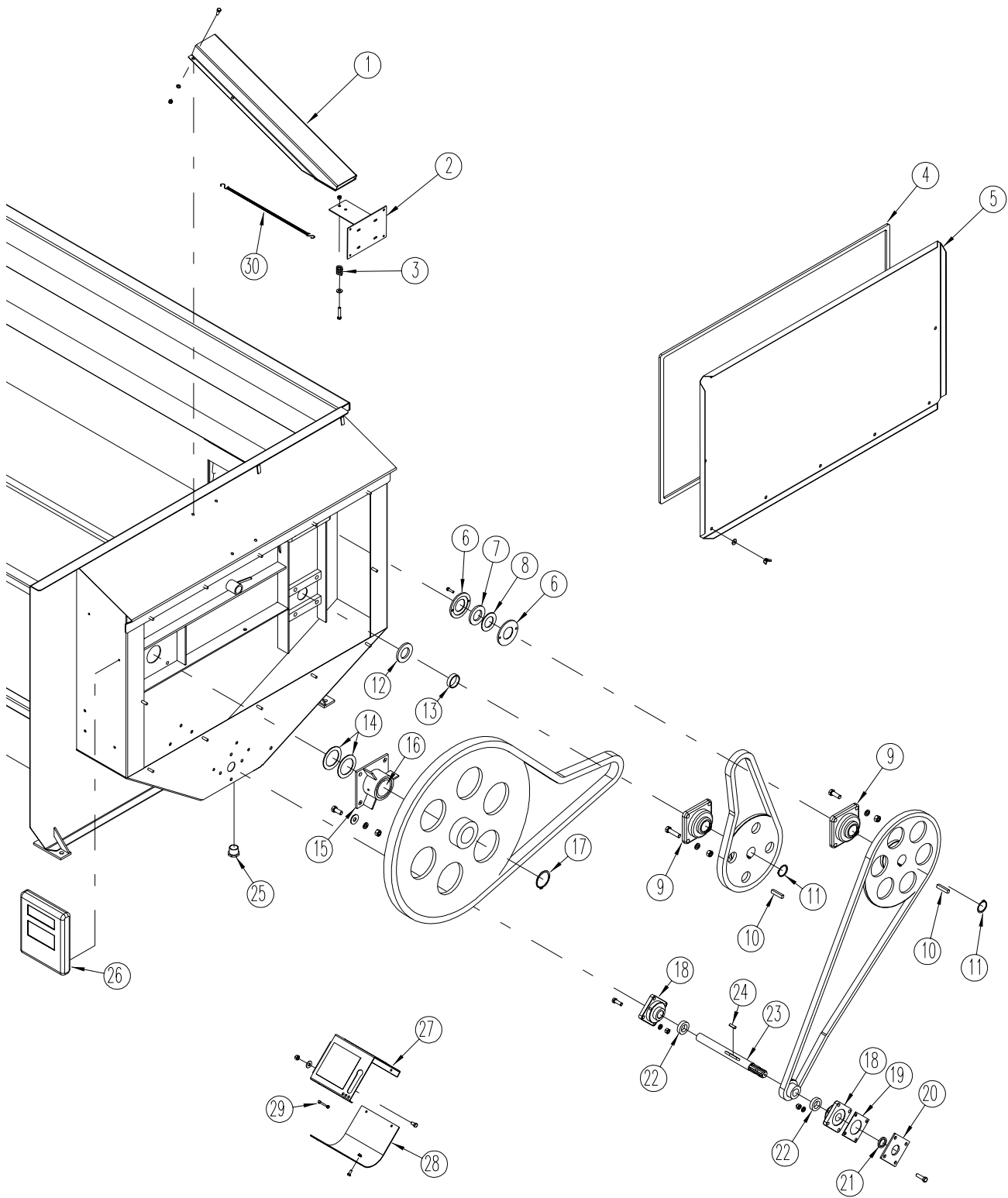

Front End Parts

REF	PART NO	QTY	DESCRIPTION
1	133-921*	1	Scale Indicator Mount Arm; Mtg Hrd: 3/8"x1" B, Lw, Nut (4ea)
2	101-835	1	Indicator Mount
3	170-238*	1	Spring, Compression 7/8" x 1-1/2"
4	171-935	15'	Front Shield Gasket; 3/8"x3/4" Closed Cell Foam
5	133-849	1	Front Shield; Mtg Hrd: 3/8" Fw and 171-929 Wing Nut (12ea)
6	133-852	2	Seal Retainer
7	133-376	1	Seal; 2" ID x 3-1/2" OD x 5/16 Thick
8	134-756	1	Seal; 2" ID x 3-3/8" OD x 1/8" Thick
9	170-008	2	Roller Bearing; Flange, 2", Mtg Hrd: 5/8" x -3/4" B, Lw, Nut (4ea)
10	170-898	2	Key; 1/2" x 1/2" x 2-1/2"
11	170-142	2	Snap Ring; 2" External
12	133-376	1	Seal; 2" ID x 3-1/2" OD x 5/16 Thick
13	133-853	1	Spacer
14	135-597	2	Reel Bearing Seal
15	102-511	1	Bearing Assembly, 3"; Mtg Hrd: 5/8" x 1-1/2" B, Fw, Lw, Nut (4ea)
16	136-309	1	Plastic Sleeve, 3"
17	171-934	1	Snap Ring; 3": External
18	171-585	2	Bearing; Flange, 1-3/8"; Mtg Hrd: 1/2" x 1-3/4" B, Lw, Nut (4ea) (Rear Bearing) 1/2" x 1-3/4" B, Lw, Nut (4ea) (Outer Bearing)
19	134-366	1	Bearing Spacer
20	136-260	1	Seal Retainer; 1/4" x 4-7/8" x 4-7/8"
21	173-164	1	Seal; 1-3/8" ID x 1 27/32" OD, 1/4" Thick C/R # 13536
22	172-193*	2	Lock Collar; 1-3/8" ID
23	136-042*	1	Input Shaft; 1- 3/8" Dia x 15-3/4"
24	171-409	1	Key; 3/8" x 3/8" x 1-1/4"
25	171-919	1	Drain Plug; 1-1/4" NPT
26	175-387	1	Operator's Manual Holder; Mtg Hrd: 5/16" x 1" B, Fw, Lw, Nut (4ea)
27	143-147*	1	PTO Shield; Mtg Hrd: 7/16" x 3/4" Bolt, Fw, Ln (3ea)
28	133-920*	1	Lower PTO Shield; Mtg Hrd: 5/16" x 3/4" Bolt, Fln
29	172-986*	1	PTO Shear Bolt, 1/4 x 2 Grade 5
30	171-936*	1	Hydraulic Hose Retaining Strap

* Parts are for Trailer model units only. See "[Stationary Motor Mount](#)" pages for stationary model front end parts

Sprockets, Chains and Tighteners

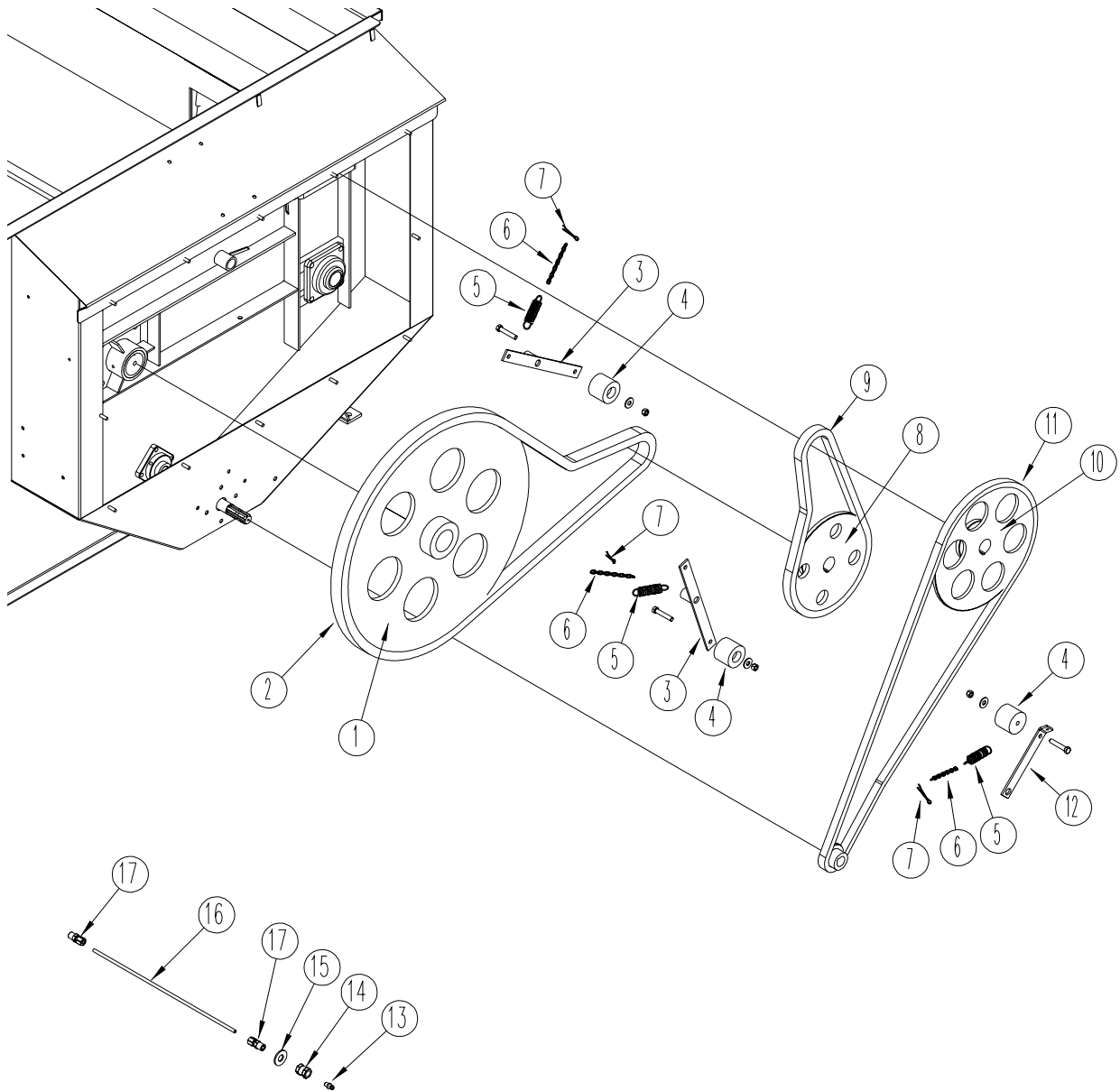

Sprockets, Chains and Tighteners

REF	PART NO	QTY	DESCRIPTION
1	133-913	1	Sprocket; 100-B-82, 3" Splined Bore
2	171-931	1	Roller Chain; 100H-1-110 Pitch, W/Connector Link
3	101-818	2	Chain Tightener Arm (#80)
4	134-155	3	Tightener Block, Mtg Hrd: 1/2" x 2 3/4" B, Fw, Lw, Nut (1ea)
5	172-006	3	Spring, Extension
6	170-478	3	Machine Chain; #4 x 12 Link (7")
7	170-800	3	Clinch Pin
8	136-908	1	Sprocket; 100-B-12, 80-42, 2" Bore
9	174-654	1	Roller Chain; 80-1-68 Pitch, W/Connector Link
10	136-907	1	Sprocket; 80-B-15/ 60-72, 2" Bore
11	174-653	1	Roller Chain; 60-1-160 Pitch, W/Connector Link
12	101-817	1	Chain Tightener Arm (#60)

GREASE LINE PARTS

13	170-865	1	Zerk, 1/8" NPT
14	172-024	1	Pipe Coupling, 1/8" NPT
15	170-244	1	Flat Washer, 3/8"
16	180-630		Grease Line Tubing (5' total length required for all grease fittings)
		18"	Required for Reel Bearing (inside oil bath)
		20"	Required for Upper Auger Bearing (inside oil bath)
		12"	Required for Lower Bearing (inside oil bath)
		20"	Required for Input Shaft Bearings (inside oil bath)
17	172-822	2	Adapter, 1/8" NPTF x 1/4" Taper

* Quantity required to complete 1 grease line assy

Stationary Motor Mount Parts

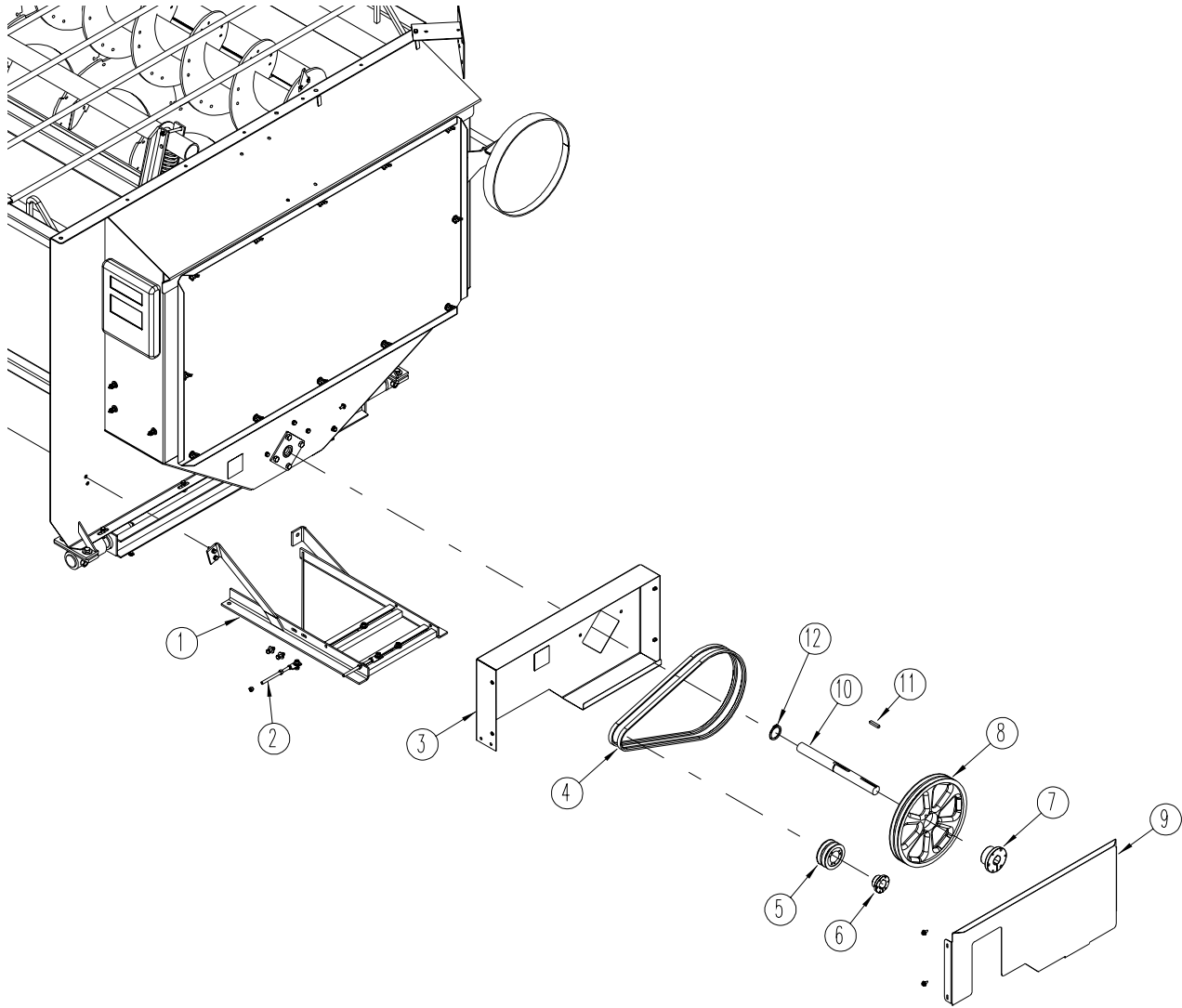

Stationary Motor Mount Parts

REF	PART NO	QTY	DESCRIPTION
1	104-081	1	Motor Mount; Mtg Hrd: 1/2" x 1" Bolt, FW, LN (5ea)
2	101-788	2	Jacking Bolt
3	104-581	1	Drive Shroud Assembly; Mtg Hrd: 7/16" x 3/4" Bolt, FW, LN (3ea) and 3/8" x 7/8" Bolt, FW, LN (2ea)
4	171-924	2	V-Belt; BX-60 Raw Edge Cog
5	171-955	1	Motor Pulley; 2 Groove, 3.95 OD SH
6	171-954	1	Bushing; 1-3/8 QD - SHX 1-3/8"
7	171-923	1	Bushing; Split Taper, 1-3/8 QD SK
8	171-921	1	Pulley; 2 Groove, 13.95 OD SK
9	140-849	1	Drive Shield; Mtg Hrd: 1/4" x 3/4" Bolt, FW, LW (4ea)
10	134-953	1	Input Shaft, 1-3/8" x 15-3/8"
11	170-627	1	Key; 5/16 x 5/16 x 1-3/4"
12	170-499	1	Snap Ring; 1-3/8" External

Reel and Auger Parts

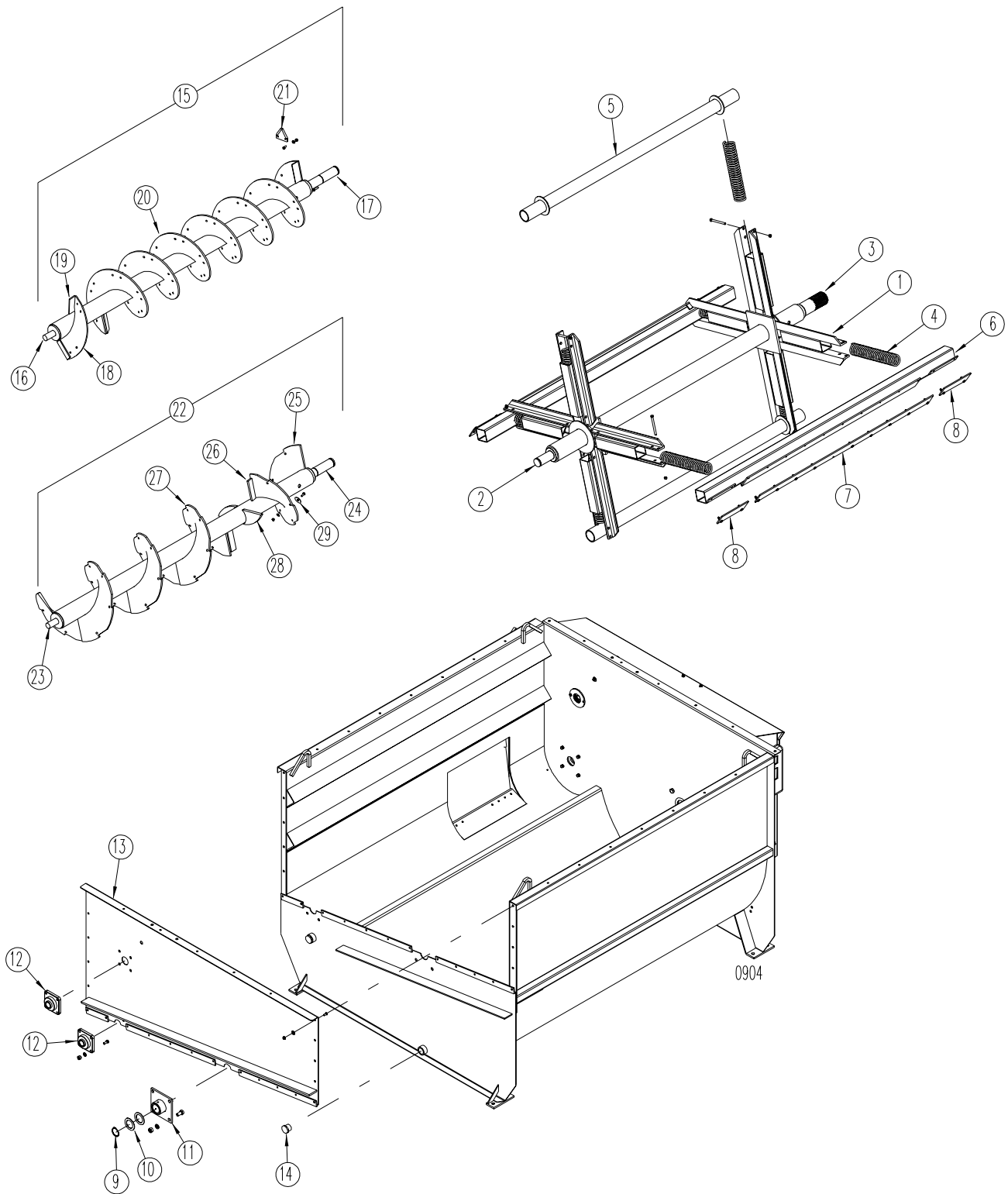

Reel and Auger Parts

REF	PART NO	QTY	DESCRIPTION
1	102-513	1	Reel Weldment
2	101-862	1	Rear Plug Assembly, 2"
3	102-510	1	Front Plug Assembly, 3"
4	171-920	8	Spring, 2-3/8"OD x 16" Lg.
5	101-888	2	Reel Cross Tube, 2-7/8"OD x 67-1/4" Lg.; Mtg Hrd: 3/8" x 4-1/2" Bolt, Ln
6	101-887	2	Wiper Tube Assembly; Mtg Hrd: 3/8" x 4-1/2" Bolt, Ln
7	134-112	2	Plastic Wiper Blade, 55-3/8" Lg.(3115) Mtg Hrd: 1/4" x 7/8" Bolt, Fw, Lw, Nut (10ea)
8	134-123	4	Plastic Wiper Blade, 8-1/2" Lg.; Mtg Hrd: 1/4" x 7/8" Bolt, Fw, Lw, Nut (2ea)
9	170-142	1	Snap Ring; 2" (Tru-Arc 5100-200 or Equiv.)
10	171-048	A/R	Washer, Special 2" ID x .049 Thk.
	171-049	A/R	Washer, Special 2" ID x .127" Thk.
11	102-260	1	Bearing Assembly; Mtg Hrd: 5/8" x 1 3/4" B, Lw, Nut (4ea)
	135-701	1	Plastic Sleeve; 2"
12	170-000	2	Bearing; 1 3/8" 4 Bolt Flanged, Mtg Hrd: 1/2" x 1 1/2" B, Lw, Nut (4ea)
13	Contact Factory	1	Rear Panel Assembly; Uses upper half of 102-509
14	171-919	2	Drain Plug; 1 1/4" PVC
15	102-495	1	Upper Auger Assembly
16	101-707	1	Rear Plug Assembly
17	101-708	1	Front Plug Assembly
18	133-833	1	Flight; 1/4" - 4" - 14" - 14" x 7" LH
19	134-758	4	Flighting Support Brace
20	134-740	2	Flight; 3/8" - 4" - 14" - 10" x 65.5" RH
21	174-558	40	Upper Auger Knife(Qty. may vary) Mtg Hrd: 1/4" x 3/4" Bolt, LW & Nut (2 ea.)
22	102-496	1	Lower Auger Assembly
23	101-709	1	Rear Plug Assembly
24	101-708	1	Front Plug Assembly
25	133-832	1	Flight; 3/8" - 4" - 16" - 16" RH
26	131-011	2	Flighting Support Brace
27	133-831	4	Flight; 3/8" - 4" - 16" - 16" LH, Actual Requirements: 3-1/2 pieces
28	134-499	2	Paddle
29	134-351	12	Lower Auger Knife; (Qty. may vary); Mtg Hrd: 3/8" x 1" Bolt, Lw, Nut

Bucket Guard Parts - Trailer Type Units

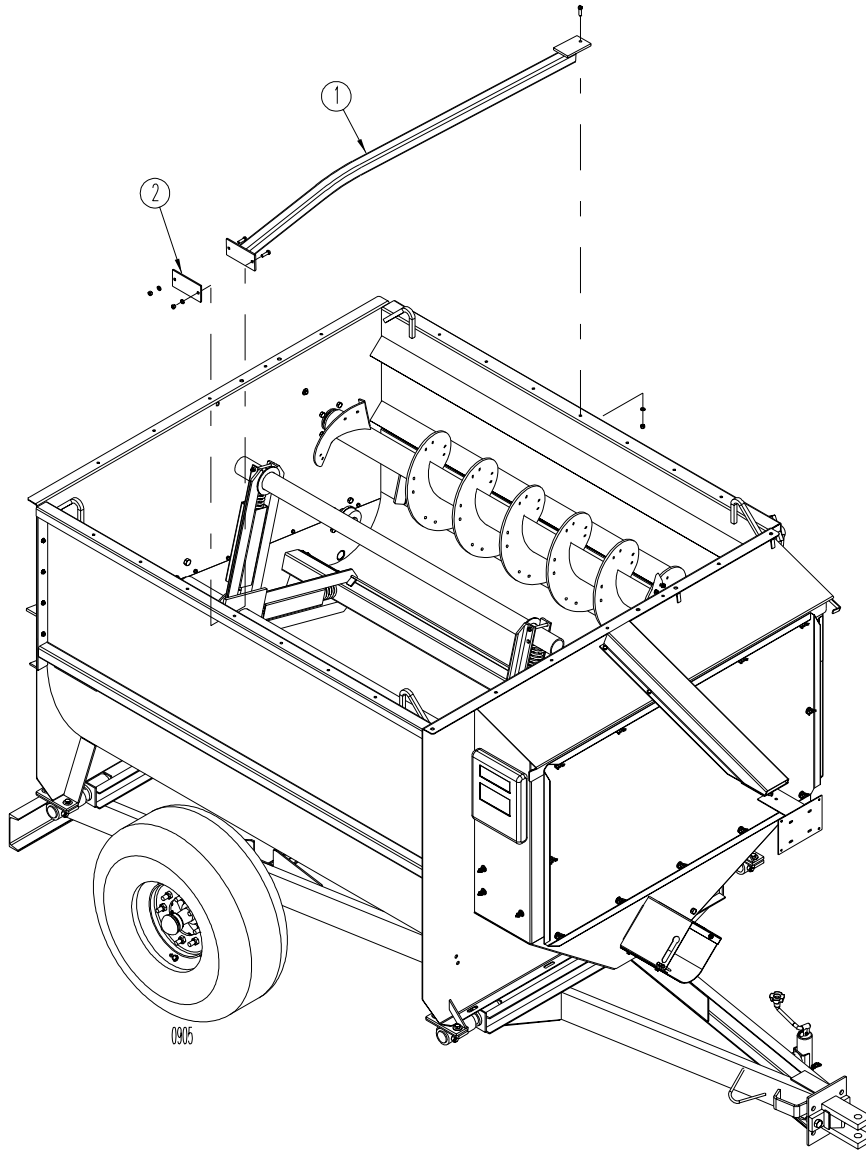

REF	PART NO	QTY	DESCRIPTION
1	102-503	1	Bucket Guard; Mtg Hrd: 3/8" x 1-1/4" Bolt, Lw, Nut (3ea)
2	134-012	1	Bucket Guard Mount Plate

Top Grid Parts - Stationary Type Units

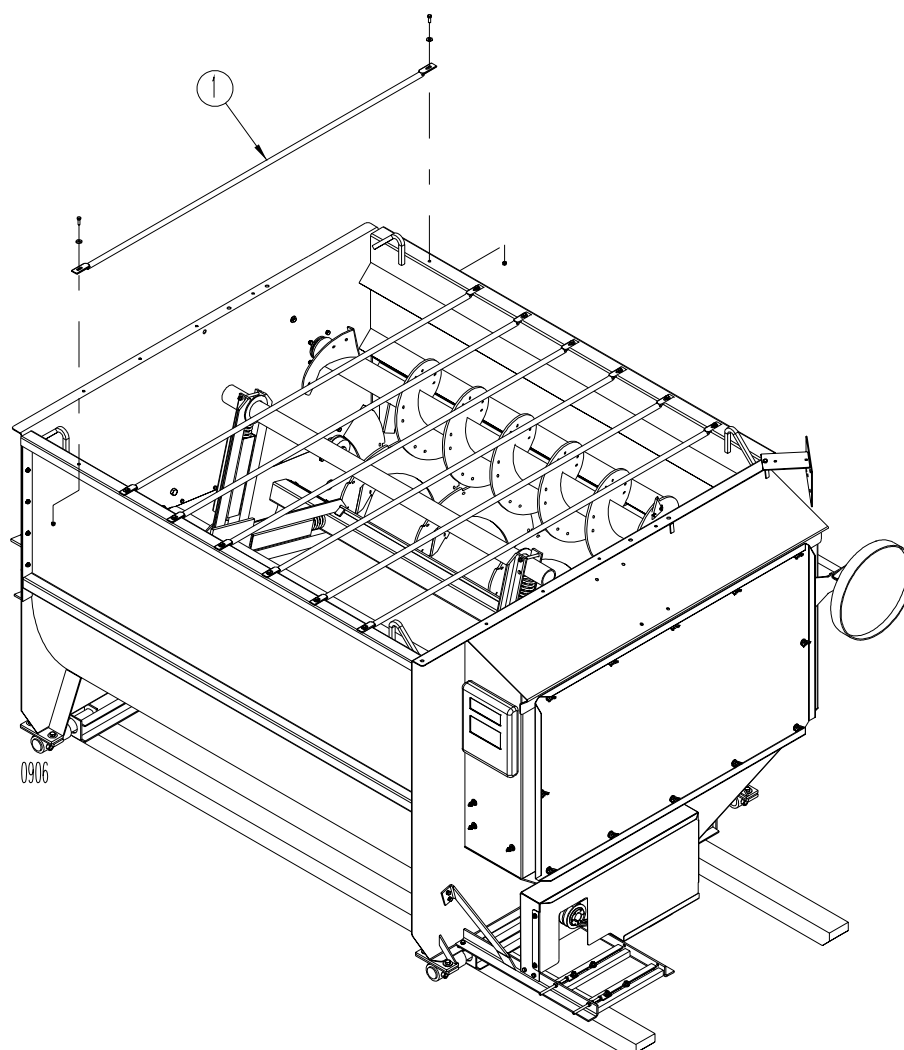

REF	PART NO	QTY	DESCRIPTION
1	134-952	7	Top Guard Pipe; Mtg Hrd: 5/16" x 1" Bolt, Fw, Ln (14ea)

Hydraulic Door Parts - Trailer Type

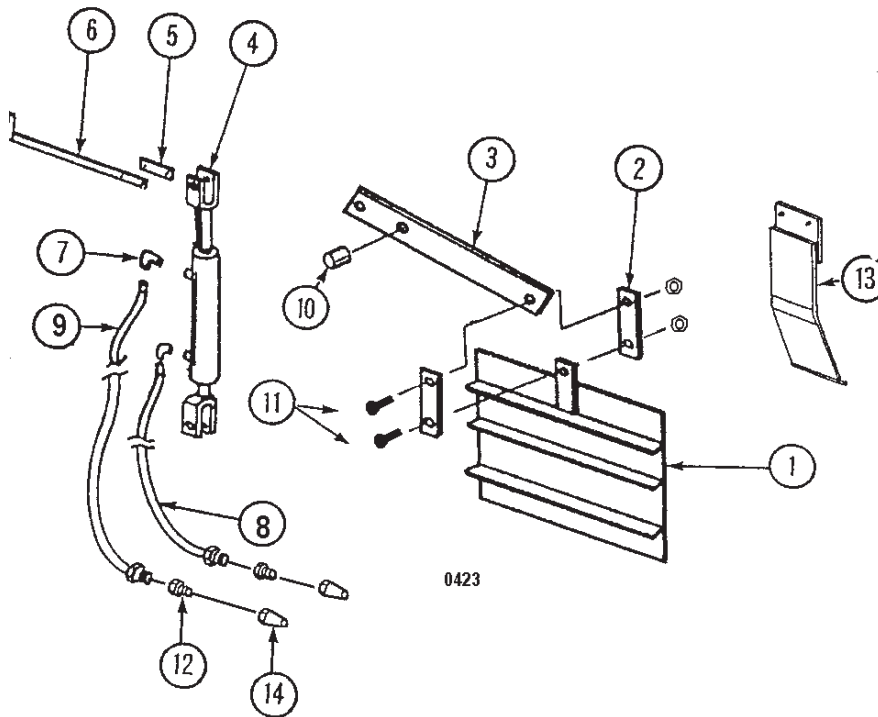

REF	PART NO	QTY	DESCRIPTION
1	102-506	1	Door Assembly
2	133-445	2	Door Linkage Bar, 3/8" x 2" x 8"
3	136-764	1	Door Pivot Bar, 5/8" x 4" x 31"
4	175-686	1	Hydraulic Cylinder; 2" x 8" Stroke ORB Ports
	173-270 ^A	1	Hydraulic Cylinder; 2" Dia x 8" Stroke (Seal Kit 170-075)
5	136-419	1	Door Gauge Mount, 1/8" x 5/8" x 3-1/4"
6	136-492	1	Door Gauge, 1/8" x 5/8" x 18-1/2"
			Mtg Hrd: 1/4" x 1" Truss Head Bolt, Lw, Nut (2ea)
7	175-673	2	Adapter; 90 Deg, 06JFS x 06JM
	171-030 ^A	2	Swivel Adapter; 3/8" - 90°
8	175-906	1	Hydraulic Hose; 1/4" x 162"
	170-468 ^A	1	Hydraulic Hose; 1/4" x 162"
9	175-907	1	Hydraulic Hose; 1/4" x 170"
	170-471 ^A	1	Hydraulic Hose; 1/4" x 170"
10	170-073	1	Pin; 1" dia. For Door Pivot Bar (133-924)
			Secures with (170-074) Hairpin Clip
11	172-381	2	Bolt; 5/8" x 2 1/2", Ln
12	175-675	2	Adapter Straight; 08OM x 06JM
	170-235 ^A	2	Reducer Bushing; 1/2" to 3/8"
13	134-345	1	Door Flow Control Plate; (Option)
			Mtg Hrd: 5/16" x 1-1/4" Bolt, Lw, Nut (2ea)
14	175-687	2	Adapter Quick Coupler
	175-536 ^A	2	Pioneer Quick Coupler

^APipe thread fittings used on units S/N A0028 and before. Please specify pipe thread or O-Ring JIC type fittings when ordering.

Door Parts - Stationary Type

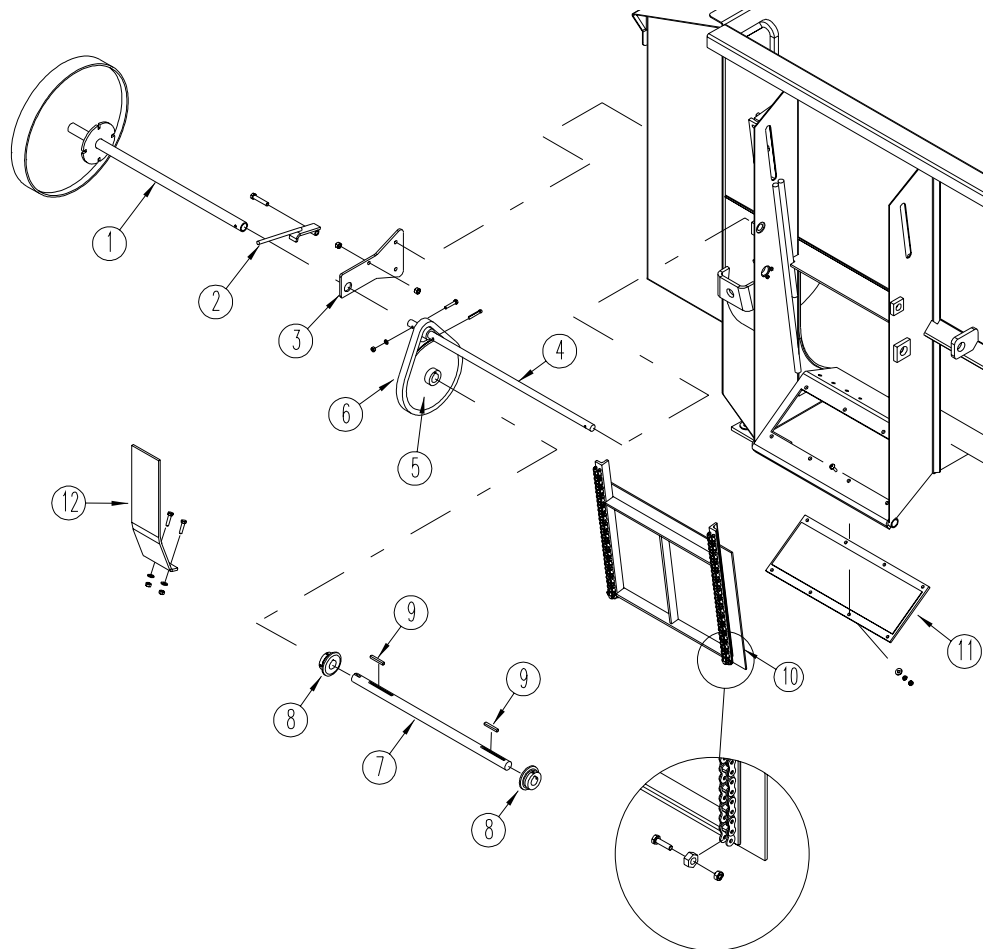

REF	PART NO	QTY	DESCRIPTION
1	104-373	1	Door Wheel Assembly; Mtg Hrd: 1/4" x 1-1/2" Bolt, Lw, Nut (1ea)
2	102-095	1	Door Wheel Lock; Mtg Hrd: 3/8" x 2" Bolt, (1ea), Ln (2ea)
3	143-384	1	Door Shaft Mount; Mtg Hrd: 3/8" x 1" Bolt, Lw, Nut (2ea)
4	101-756	1	Door Control Shaft/ Sprocket Assy.; Mtg Hrd: 170-521 Pin (1ea)
5	134-235	1	Sprocket; 50-B-42, 1" Bore, 1/4" Keyway (170-120 Woodruff Key, 1/4" x 7/8")
6	171-178	1	Roller Chain; 50-1-48 P
7	134-242	1	Door Control Shaft
8	130-785	2	Sprocket; 50-B-12, 1" Bore, 1/4" Keyway
9	171-012	2	Key; 1/4" x 1/4" x 1-7/8"
10	101-848	1	Door Assembly; Door Stop 1/4-20 x 1" Bolt, 3/8" Nut and 1/4" Ln (2ea)
11	171-346	1	Magnet; Mtg Hrd: 1/4" x 3/4" Truss Head Bolt, Fw, Lw, Nut (8ea)
12	134-345	2	Door Restrictor Plate; Mtg Hrd: 5/16" x 1-1/4" Bolt, Lw, Nut (2ea)

Electric Door Parts - Stationary Type (Optional)

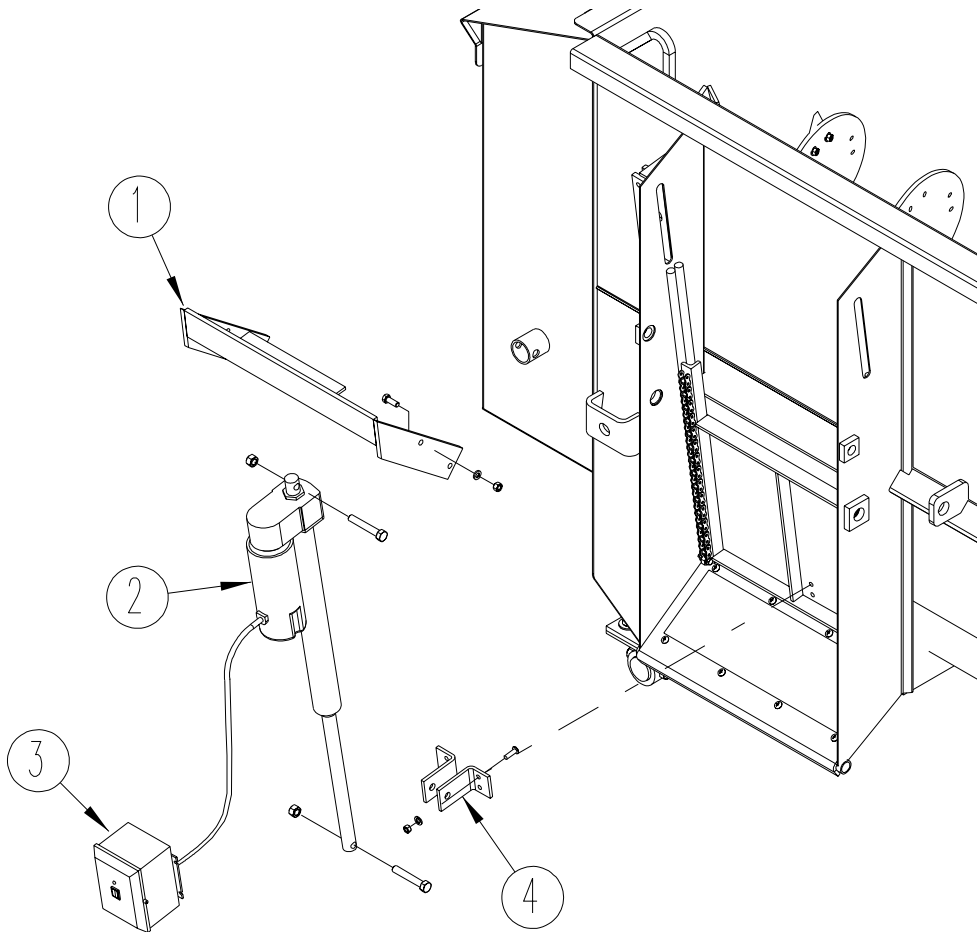

REF	PART NO	QTY	DESCRIPTION
1	101-821	1	Actuator Mount; Mtg Hrd: 3/8" x 1" Bolt, Lw, Nut (4ea)
2	171-632	1	Actuator and Control Box; Mtg Hrd: 1/2" x 2-1/2" Bolt, Ln (2ea)
3	101-822	1	Switch Box Assembly
4	134-161	2	Actuator Door Mounts; Mtg Hrd: 5/16" x 1" Truss Head Bolt, Fln (2 each Bracket)

Slide Tray Parts - Trailer Type (Optional)

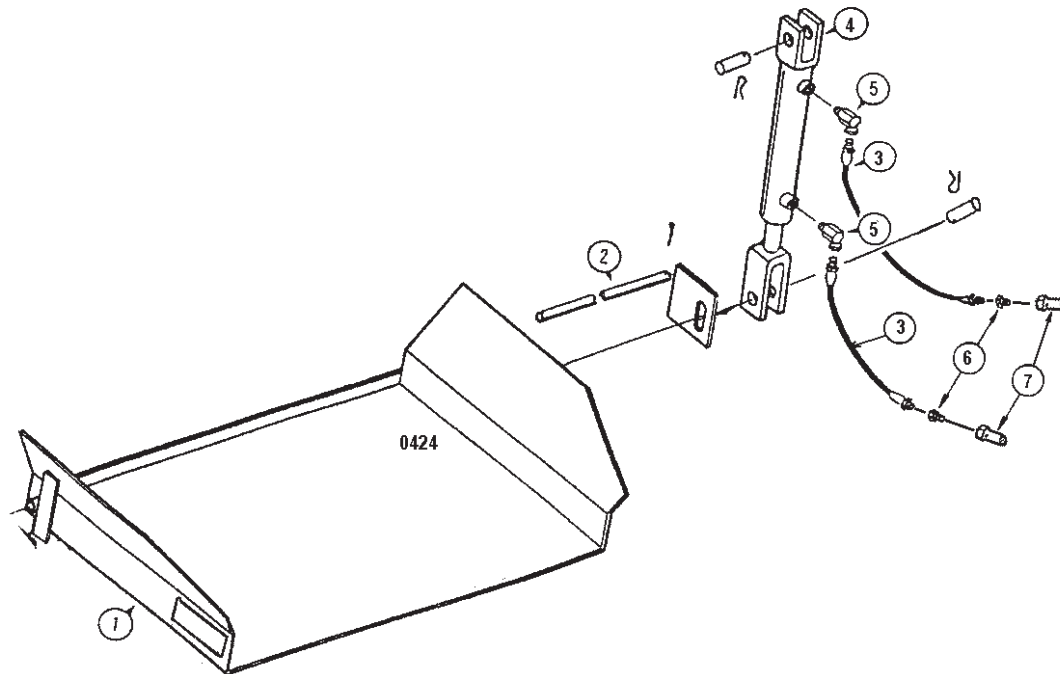

Pipe Thread Fittings and Hoses

REF	PART NO	QTY	DESCRIPTION
1	102-505	1	Slide Tray Assembly(See Decal Section For Decals)
2	136-761	1	Pivot Rod, 3/4" x 39-1/2" Lg. (secure with 170-115 cotter pin; 2ea)
3	175-927	2	Hydraulic Hose; 1/4" x 190"
	171-464 ^A	2	Hydraulic Hose; 1/4" x 190"
4	175-686	1	Hydraulic Cylinder; 2" x 8" Stroke (ORB Ports) Seal Kit
	173-270 ^A	1	Hydraulic Cylinder; 2" x 8" (Seal Kit # 170-075)
5	175-673	2	Adapter, 90 Deg, 06JFS x 06JM
	171-030 ^A	2	Swivel Connector; 3/8" x 90°
6	175-675	2	Adapter Stratght; 08OM x 06JM
	170-235 ^A	2	Reducer Bushing; 1/2" to 3/8"
7	175-687	2	Adapter, Quick Coupler
	175-536 ^A	2	Pioneer Quick Coupler

^APipe thread fittings used on units S/N A0028 and before. Please specify pipe thread or O-Ring JIC type fittings when ordering.

Adjustable Slide Tray Parts - Optional Trailer Type

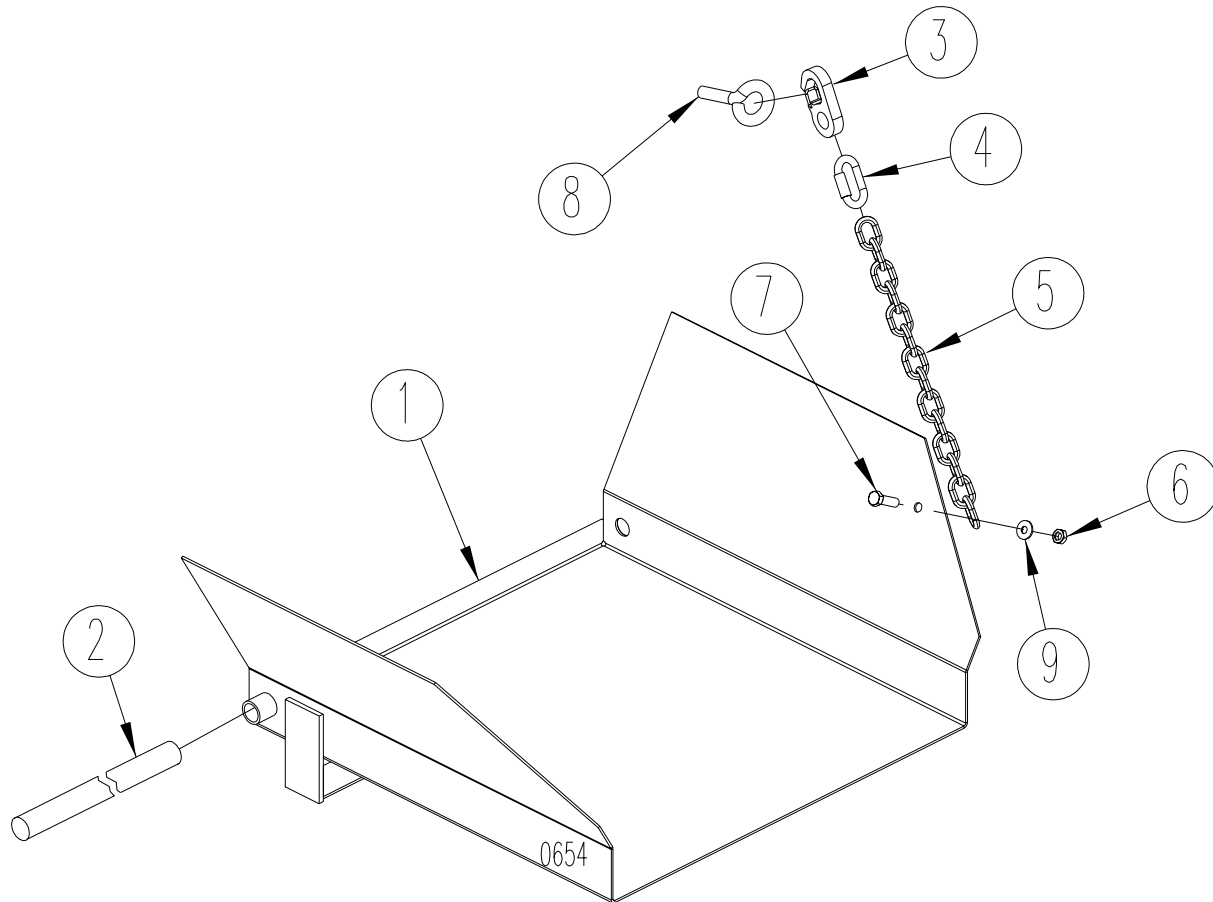

REF	PART NO	QTY	DESCRIPTION
1	102-505	1	Slide Tray Assembly (See Decal Section For Decals)
2	136-761	1	Pivot Rod, 3/4" x 39-1/2" Lg. (secure with 170-115 cotter pin; 2ea)
3	175-313	1	Snap, Safety
4	175-312	1	Connector, Threaded
5	141-608	1	Chain
6	170-047	1	Nut, Lock, 3/8"
7	170-005	1	Bolt, Hex, 3/8" x 1 1/4"
8	175-311	2	Bolt, Eye; Mtg. Hrd: 1/2" Nut (170-004) (2ea)
9	170-244	1	Flat Washer; 3/8"

Selector Valve Parts - Trailer Type (Optional)

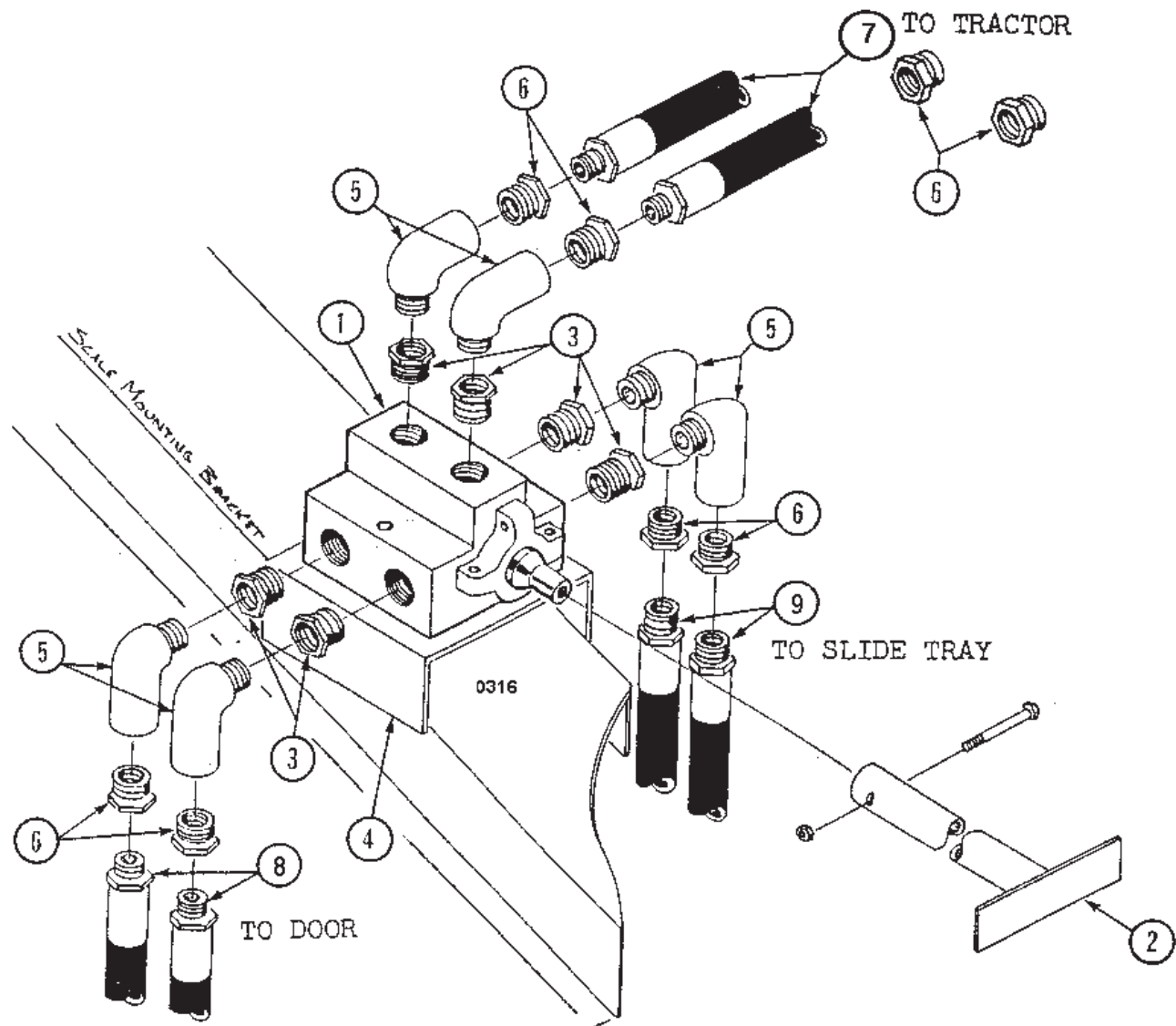

REF	PART NO	QTY	DESCRIPTION
1	101-891	1	Selector Valve Assembly (Seal Kit # 172-784); Mtg Hrd: 3/8" x 3" Bolt, Fw, Lw, Nut (2ea)
2	101-791	1	Control Handle Assembly; Mtg Hrd: 1/4" x 1-1/2" Bolt, Ln
3	171-430	6	Reducer Bushing; 3/4" Male to 1/2" Female
4	134-136	1	Valve Bracket, Mtg Hrd: 5/16" x 3/4" B, Lw, Nut (4ea)
5	171-136	6	Street Elbow; 1/2" - 90°
6	170-235	8	Reducer Bushing; 1/2" Male to 3/8" Female
7	171-998	2	Hydraulic Hose 1/4" x 118"
8	170-465	2	Hydraulic Hose 1/4" x 127"
9	170-468	2	Hydraulic Hose 1/4" x 162"

Undercarriage Parts

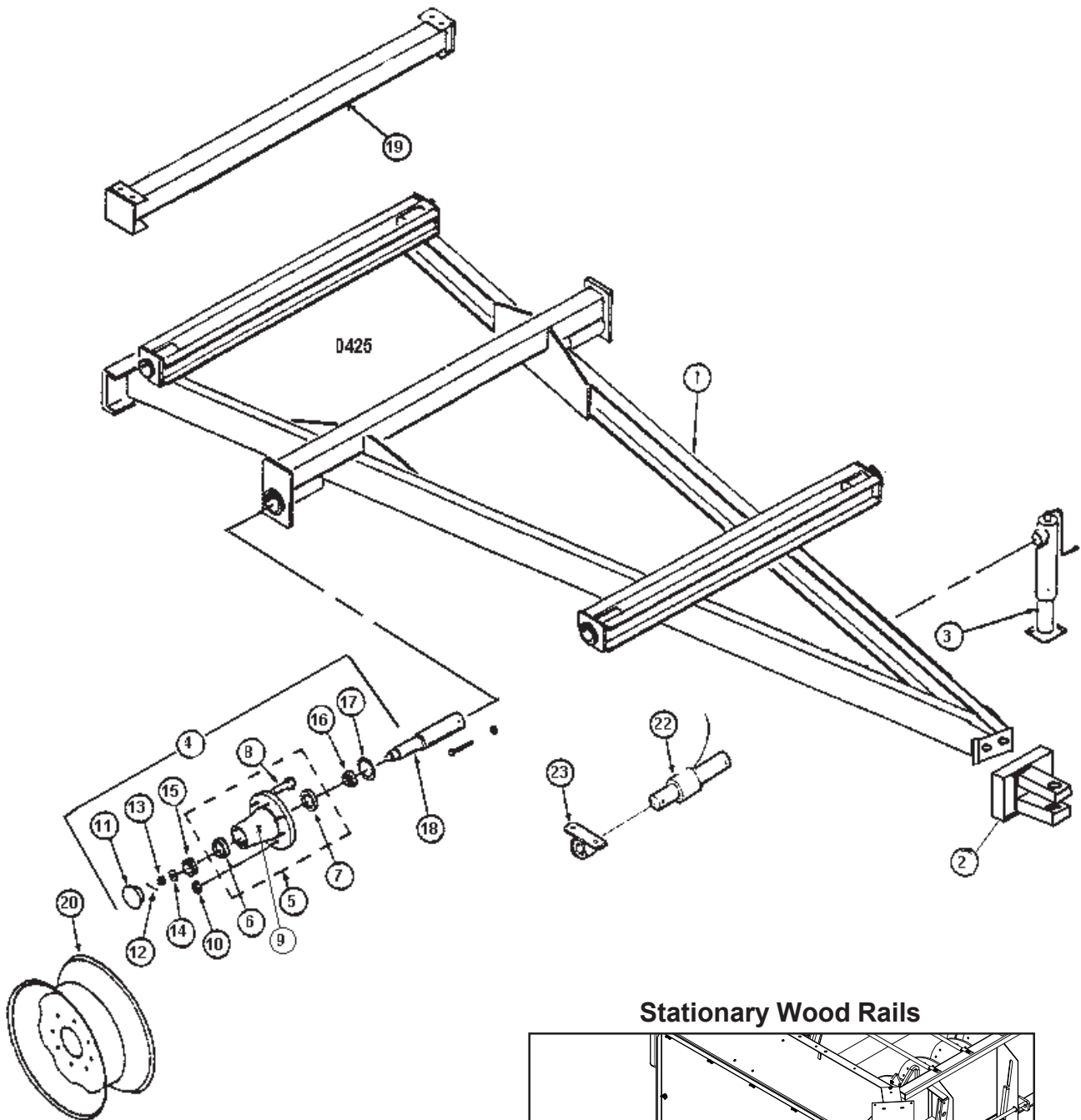

Stationary Wood Rails

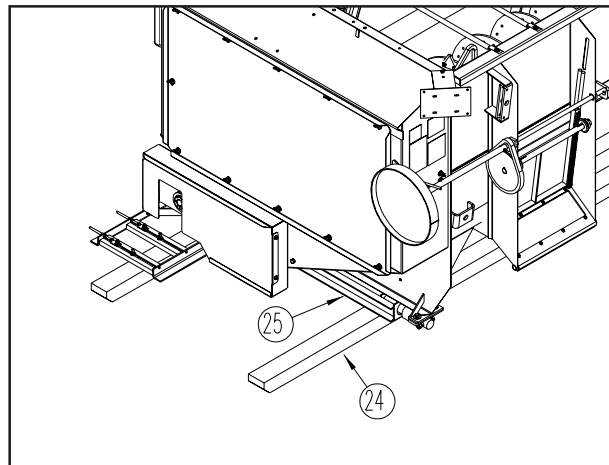

Undercarriage Parts

REF	PART NO	QTY	DESCRIPTION
1	102-501	1	Undercarriage Weldment
2	101-741	1	Tongue Clevis Assy; Mtg Hrd: 3/4" x 2" Bolt, (grd8) Ln, (grd 8) (2 ea)
3	170-984	1	Jackstand (refer to jackstand parts pages for parts breakdown)
4	174-587	2	8-Bolt Hub Assembly (Use after 4/99)
5	174-582	2	8-Bolt Hub
6	171-825	1	Outer Bearing Race (Timken # LM501310) or Equiv.
7	174-583	1	Inner Bearing Race (Timken # JLM506810) or Equiv.
8	174-586	8	Stud; 5/8" NF
9	170-865	1	Grease Zerk, 1/8" NPT
10	171-827	8	Nut; 5/8" NF (171-827 Included with 174-582)
11	171-830	2	Dust Cap
12	170-056	2	Cotter Pin; 1/4" x 2"
13	171-833	2	Castle Nut; 1" NF Wheel Nut
14	171-832	2	Flat Washer, 1" Heavy
15	171-829	2	Outer Bearing Cone (Timken # LM501349) 2.165 or Equiv.
16	174-584	2	Inner Bearing Cone (Timken # 387AS) or Equiv.
17	174-585	2	Grease Seal (C/R 25091) or Equiv.
18	136-990	2	Spindle; 2-1/2" x 14" Mtg Hrd: 3/8" x 4" Bolt & LN
19	101-909	2	Riser Option; Mtg Hrd: 5/8" x 1-3/4" Bolt, LN (8ea)
20	170-844	2	Wheel; 15" x 10, 8 - Bolt
	171-535	2	12.5L X 15 Implement Tire (Not Pictured)
22	172-139	4	Weigh Bar; 1-7/8" Dia, (DigiStar)
	173-229	4	Weigh Bar; 1-7/8" Dia; Mtg Hrd: 5/8" x 3-1/2" Bolt, Ln(1ea) (Weigh-Tronix)
	136-762	4	Dummy Weigh Bar Mount (For Units Without Scales)
23	102-504	4	Weigh Bar Mount Spool
24	171-817	2	Wood Skid Rail, 3" x 4" x 120" (Stationary Only)
			MtgHrd: 3/8" x 3-1/2" Carriage Bolt, Fw, Nut, (4ea), 5/16" Fw (2ea)
25	101-876	2	Weigh Bar Mount Beam, (Stationary Only)

Scale Parts

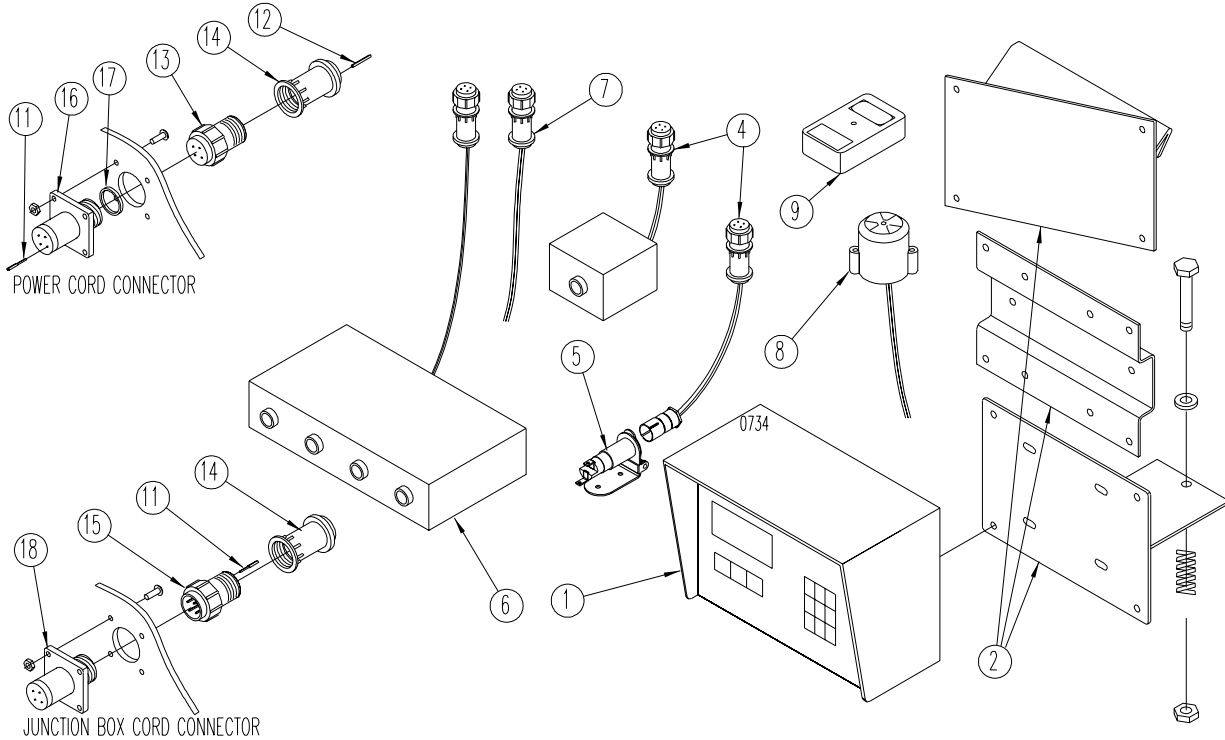

REF	PART NO	QTY	DESCRIPTION
1	172-128	1	Digi-Star Model EZ-2000 Basic Indicator, 1" high display
	172-800	1	Digi-Star Model EZ-2000V Indicator, 1.7" high display
	172-130	1	Digi-Star Model EZ-3200 Indicator, 1" high display
	174-501	1	Digi-Star Model EZ-3200 Indicator (serial port), 1" high display
	175-209	1	Digi-Star Model EZ-3200 Indicator (with rev counter and serial port), 1" high display
	172-500	1	Digi-Star Model EZ-3200V Indicator, 1.7" high display
	174-502	1	Digi-Star Model EZ-3200V Indicator (with serial port), 1.7" high display
	175-210	1	Digi-Star Model EZ-3200V Indicator (with rev counter and serial port), 1.7"high display
	175-211	1	Digi-Star Model EZ-3500 Indicator (with rev counter and serial port), 1" high display
	175-212	1	Digi-Star Model EZ-3500V Indicator (with rev counter and serial port), 1.7" high display
	172-803	1	Digi-Star RD 2000 Remote, 1" high display w/ 25' Cord
	172-801	1	Digi-Star RD 2000V Remote, 1.7" high display w/ 25' Cord
	172-804	1	Digi-Star RD 2000 T/R Remote, 1" high display w/ Transmitter & 25' Cord
	172-802	1	Digi-Star RD 2000V T/R Remote, 1.7" high display w/ Transmitter & 25' Cord
			Mtg Hrd for Digi-Star indicators: 1/4" x 3/4" Bolt, Flat washer, Lock washer & N (2 ea)
	173-225	1	Weigh-Tronix Model 615 Basic Indicator, 1" high display
	173-226	1	Weigh-Tronix Model 615XL Basic Indicator, 2" high display
	173-227	1	Weigh-Tronix Model 715 Indicator, 1" high display
	174-503	1	Weigh-Tronix Model 715 Indicator (serial port), 1" high display
	175-574	1	Weigh-Tronix Model 1040 Indicator, 1.1 high display (serial and remote ports)
	175-575	1	Weigh-Tronix Model 1040 Indicator, 2" high display(speed sensor & dual serial ports)
	175-576	1	Weigh-Tronix Model 1040 Indicator, (serial & remote ports) 2" high display
	175-577	1	Weigh-Tronix Model 1040 Indicator (speed sensor & dual serial ports), 1.1 high display
	175-045	1	Weigh-Tronix Model 2015 Indicator (with serial port), 1" high display
	174-505	1	Weigh-Tronix 712 Remote, 1" high display w/ 30' Cord
	174-506	1	Weigh-Tronix 712XL Remote, 2" high display w/ 30' Cord
	174-507	1	Weigh-Tronix 1012 Remote, 1" high display w/ 30' Cord
	175-074	1	Weigh-Tronix 1012XL Remote, 2" high display w/ 30' Cord
	175-578	1	Weigh-Tronix RD64 Remote, 1.1" high display w/ 30' Cord
	175-579	1	Weigh-Tronix RD64XL Remote, 2" high display w/ 30' Cord
	175-595	1	Weigh-Tronix RD125RF Wireless Remote, 1" high display w/ power cord

Scale Parts

REF	PART NO	QTY	DESCRIPTION
2	101-835	1	Indicator Mount Mtg Hrd: Spring (170-238) 3/8" x 2" Bolt, Flat washer & Lock nut
	134-409	1	Remote indicator mount, Mtg Hrd: 5/16" x 3/4" Bolt, Lock washer, Nut (2 ea)
	102-772	1	Angled remote indicator mount, Mtg Hrd: 5/16" x 3/4" Bolt, Lock washer, Nut (2 ea)
3	175-051	1	Digi-Star RD1000 remote mirror mount (not shown)
	175-052	1	Mirror mount for Digi-Star above (not shown)
	175-046	1	Weigh-Tronix 1012M remote mirror mount (not shown)
	175-582	1	Weigh-Tronix RD64M remote mirror mount (not shown)
	175-583	1	Mirror mount for Weigh-Tronix above (not shown)
	175-569	1	Digi-Star RD1000 Wireless remote, 1" high display w/ power cord (not shown)
	175-048	1	Digi-Star RF900 tranceiver for above
	175-049	1	Replacement cable for RF900 tranceiver (not shown)
	175-050	2	Magnet mount for above tranceiver (not shown)
4	172-183	1	Power cord assy, stationary application or unit with revolution counter
	172-354	1	Power cord assy, trailer and truck application with out rev counter
	172-136	1	Power supply 120 VAC input, 4-6 AMP 13.8 VDC
5	170-415	1	Plug, tractor mount
6	103-052	1	Junction Box W/15' cable; #10 x 1" Sheet metal screw (2 ea)
	173-156	1	15' Replacement junction box cable
	172-166	1	10' Junction box extension cable (not shown)
	172-165	1	30' Junction box extension cable (not shown)
7	174-719	1	Digi-Star Remote indicator cord (not shown)
	174-003	1	Digi-Star dual remote cable (not shown)
8	101-917	1	Digi-Star Alarm horn assembly Mtg Hrd: #6 x 3/4" Bolt, Lock washer, Nut (2 ea)
	101-918	1	Weigh-Tronix Alarm horn assembly Mtg Hrd: #6 x 3/4" Bolt, Lock washer, Nut (2 ea)
9	172-143	1	Digi-Star D-22A hand held transmitter (Installed Receiver is Required)
	174-926	1	Digi-Star DXT-21 hand held transmitter (Installed Receiver is Required)
	172-350	1	Weigh-tronix hand held transmitter (Installed Receiver is Required)
10	175-626	1	Weigh-Tronix printer (not shown)
	175-627	1	Weigh-Tronix printer data cord (not shown)
	175-628	1	Weigh-Tronix printer paper 1 roll (not shown)
	174-000	1	Digi-Star printer (not shown)
	174-002	1	Digi-Star printer power cord (not shown)
	174-001	1	Digi-Star printer data cord (not shown)
	174-004	1	Digi-Star printer paper 1 roll (not shown)
11	173-211	4	Contact pin
12	173-212	4	Contact socket
	173-216	1	Pin extraction tool (not shown)
13	173-213	1	Power cord connector
	174-923	1	Nut, connector
14	173-214	1	Strain relief
15	173-215	1	Junction box cord connector
	174-923	1	Nut, connector
16	173-217	1	Power connector chassis
17	173-218	1	Seal for power connector chassis
18	173-219	1	Load cell connector chassis
19	171-158	1	Battery box (not shown)
20	171-380	2	Battery terminals (not shown)
21	171-936	1	Battery hold-down strap (not shown)
22	132-988	1	16 Ga. Ground (not shown)
23	172-386	1	Precision calibrator for scale indicators (not shown)
24	171-960	1	Cord splice kit (not shown)

Refer to subframe or undercarriage mounting section for weigh bars or load cells for your specific application.

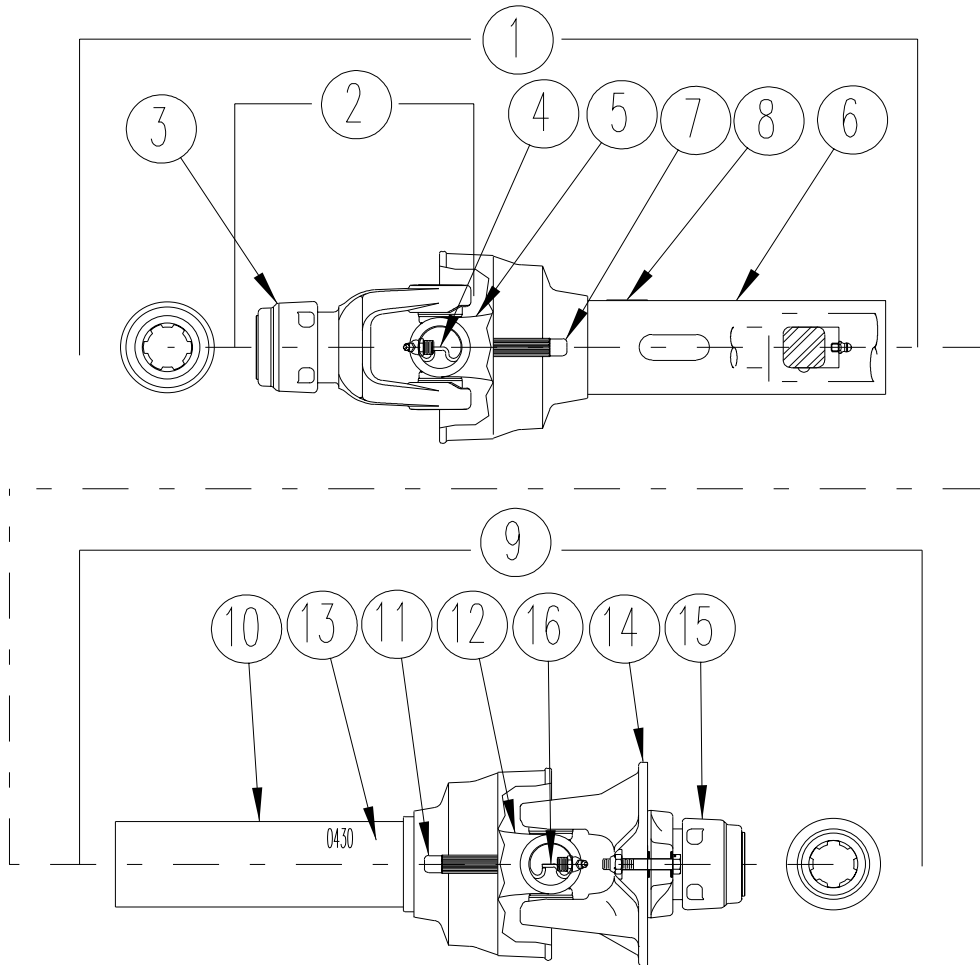
PTO Driveline - 540 RPM - 6 Spline - 1-3/8" Yoke

REF	PART NO	QTY	DESCRIPTION
	173-428	1	Driveline Complete
1	171-751	1	Joint and Shaft Half with Guard
2	172-018	1	Yoke Assembly
3	172-019	1	Safety Slide Lock Repair Kit
4	170-720	1	Cross and Bearing Kit
5	171-753	1	Yoke and Shaft
6	171-756	1	Outer Guard
7	170-220	1	Nylon Repair Kit
8	171-550	1	Safety Decal
9	173-427	1	Joint and Tube Half with Guard
10	171-755	1	Inner Guard
11	170-220	1	Nylon Repair Kit
12	171-754	1	Yoke Tube and Slip Sleeve
13	171-799	1	Safety Decal
14	172-926	1	Shear Yoke Assembly
	172-986	1	Shear Bolt; 1/4" x 2" (grade 5)
	170-069	1	Lock Nut; 1/4" (grade 5)
15	172-019	1	Safety Slide Lock Repair Kit
16	170-720	1	Cross and Bearing Kit

Jackstand Parts

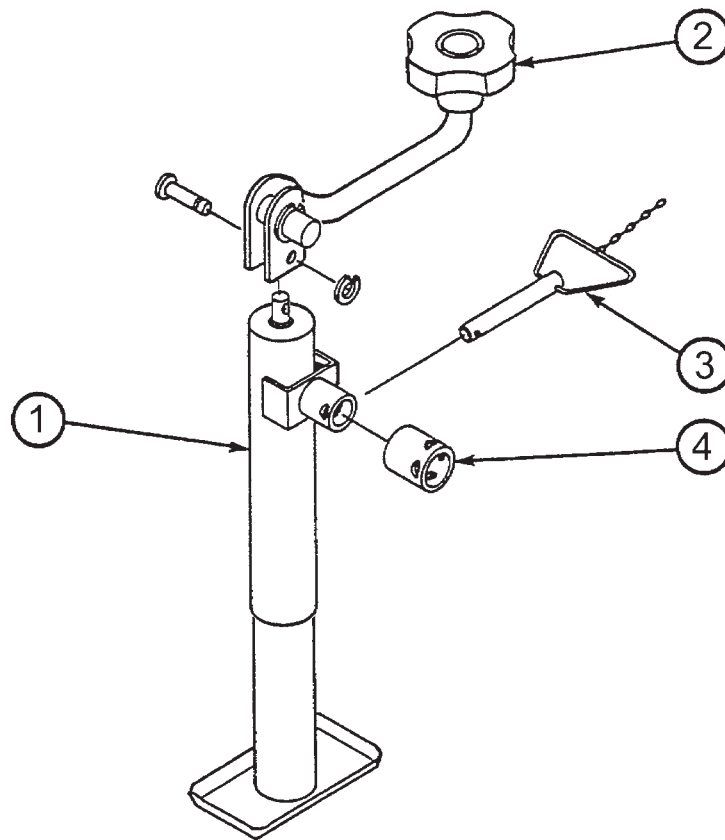

REF	PART NO	QTY	DESCRIPTION
1	170-984	1	Jackstand Assembly
2	170-386	1	Crank Assy
3	170-987	1	Pin and Chain Assy
4	170-985	1	Mount Tube

HAY MAXX System

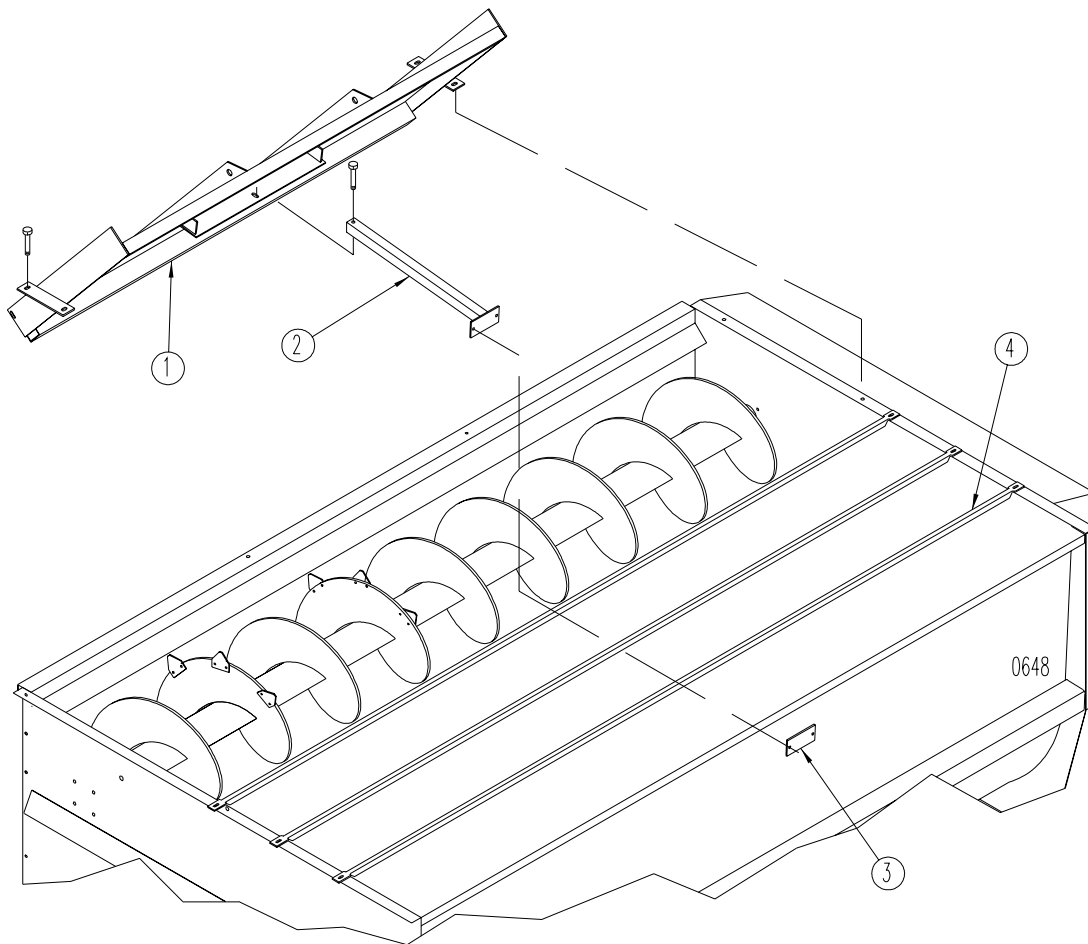

REF	PART NO	QTY	DESCRIPTION
1	102-499	1	HAY MAXX Haypan Attachment; Mtg Hrd: 1/2" x 1-1/2" B, LN (4ea.), 1/2" x 1-1/2" B, Ln (2ea.) Shim with 1/2" FW (As Required)
2	102-502	1	Bucket Guard; Mtg Hrd: 3/8" x 1-1/4" B, LW, N (2ea.), 1/2" x 3" B, FW, LN (1ea)
3	134-012	1	Bucket Guard Mount (May require additional quantities as spacer inside unit)
4	141-597	3	Top Guard; (Stationary Only) Mtg Hrd: 1/2" x 1-1/2" Bolt, Fw, and Nut (2ea)

Repair Liner Parts

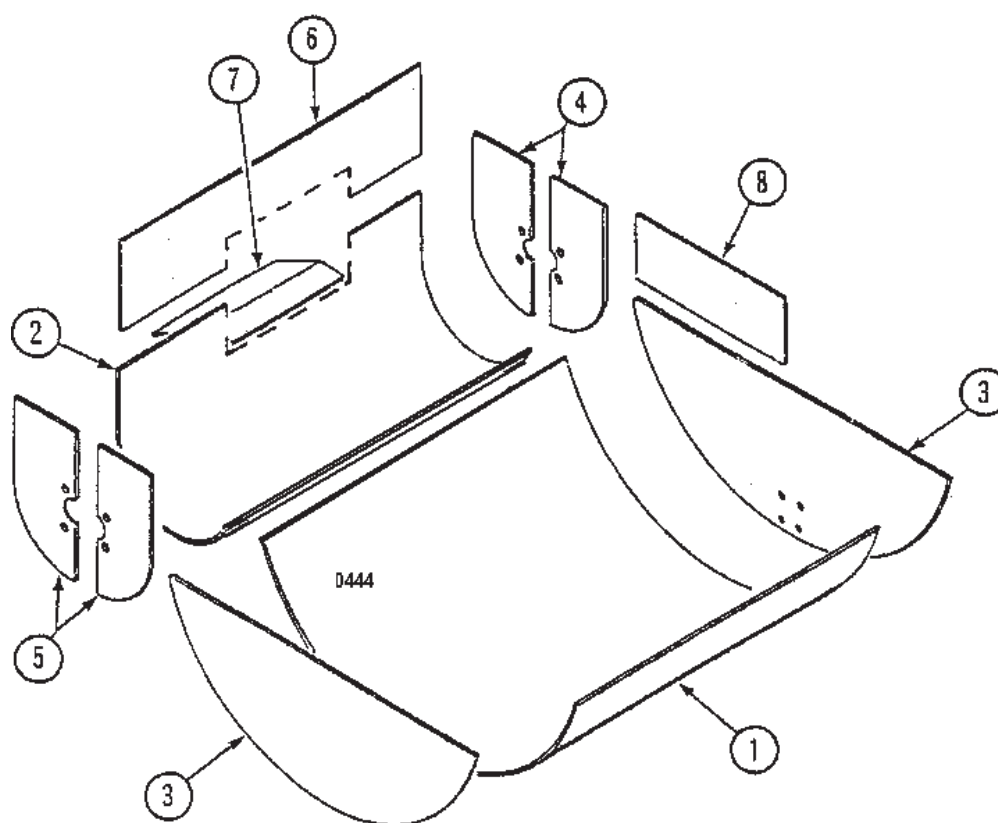

REF	PART NO		QTY	DESCRIPTION
	Mild Steel	Stainless Steel		
1	134-709	141-581	1	Reel Liner
2	134-710	141-579	1	Auger Liner
3	134-703	141-580	2	Reel End Panel
4	134-707	141-577	1	Auger End Liner (<i>front</i>)
5	134-708	141-578	1	Auger End Liner (<i>rear</i>)
				Part number includes both left and right halves.
6	134-704	141-576	1	Upper Door Liner
7	134-706	141-575	1	Door Opening Liner
8	134-705	141-582	1	Upper Reel End Liner

Decals

The following decals are listed below for your convenience.
Use the operator's manual for decal location and part number ordering.

PART NO	QTY	DESCRIPTION
175-871	1	Complete Set of Decals
174-632	1	Complete Set of Decals (Before 10/15/2004)
174-514	3	"KUH N KNIGHT" logo (Before 10/15/2004)
173-447	2	"REEL AUGGIE" (Before 10/15/2004)
173-448	11'	Black Stripe (Before 10/15/2004)
170-849	3	WARNING, Stay Clear Of Power Driven Parts
171-712	1	Retighten Setscrews...
171-820	4	DANGER, Rotating Auger Inside
170-490	1	Reduce Engine RPM...
174-551	2	"3115" (Before 10/15/2004)
171-911	1	CAUTION, Operating Precautions
171-913	1	WARNING, Do Not Operate Unless Shields Are In Place
171-915	1	DANGER, Do Not Operate! Shield Missing
171-947	4	DANGER, Do Not Hand Load
171-948	1	BEWARE, Operating Mixer While Loading
171-949	1	Patent Information
172-292	1	Mixer Fill Line
170-893	1	SMV
171-748	1	Door Height Gauge
171-916	1	Danger, Stay Clear of Rotating...
172-820	1	CAUTION, Lifting Instructions
172-883	1	Oil Level Plug
173-040	1	CAUTION, PTO Operation
173-044	1	Made in Wisconsin
172-449	1	HAY MAXX System
174-556	1	"HAY MAXX SYSTEM"
174-686	2	Red Reflector
175-757	1	"Kuhn Knight" Logo, 10" high
175-799	5'	Multi-Stripe, 5"
175-800	3	"Kuhn Knight" Logo, 15" high
175-820	2	"3115"
175-849	2	"Reel Auggie" w/Stripe

Paint

175-787	Sierra Gold - Aerosol Can	170-366	Kuhn Knight Yellow - Aerosol Can
175-788	Sierra Gold - Quart Can	170-812	Kuhn Knight Yellow - Quart Can
175-789	Sierra Gold - Gallon Can	170-813	Kuhn Knight Yellow - Gallon Can

Optinal Kits

172-195	Tow Safety Chain, 20,000#
174-675	Highway Light Kit
172-442	Electric Switching Valve
101-909	Six Inch Riser Kit

Hardware Part Number Listing

All fasteners are NC thread, Grade 5 unless otherwise specified.

HEX HEAD BOLTS

Size	Part No		
1/4 x 1/2	173-279	1/2 x 1-1/2 (Grade 8)	172-951
1/4 x 3/4	170-803	1/2 x 1-3/4	171-774
1/4 x 7/8	171-094	1/2 x 2	171-802
1/4 x 1	170-310	1/2 x 2-1/4	172-387
1/4 x 1-1/2	170-068	1/2 x 2-1/2	170-885
1/4 x 2	172-986	1/2 x 2-1/2 (Full thread)	171-099
1/4 x 2 (Grade 8)	175-073	1/2 x 2-3/4	172-007
1/4 x 2-3/4	171-203	1/2 x 3	170-168
1/4 x 3	171-403	1/2 x 3-1/2	170-167
1/4 x 3-1/2	173-640	1/2 x 3-1/2 (Grade 8)	172-950
1/4 x 4	173-505	1/2 x 4	173-111
5/16 x 5/8	170-532	1/2 x 4 (Full thread)	171-509
5/16 x 3/4	170-262	1/2 x 4-1/2	175-920
5/16 x 3/4 (Stainless steel)	174-787	1/2 x 4-1/2 (Grade 8)	171-573
5/16 x 7/8	170-256	1/2 x 5	171-412
5/16 x 1	170-027	1/2 x 6	173-506
5/16 x 1-1/4 (Full thread)	170-188	1/2 x 6 (Grade 8)	174-944
5/16 x 1-1/2	170-372	1/2 x 6-1/2	173-711
5/16 x 1-3/4	170-263	1/2 x 7	174-328
5/16 x 2	172-987	1/2 x 7-1/2	175-107
5/16 x 2-1/2	170-369	1/2 x 8-1/2	170-504
5/16 x 3	170-295	1/2 x 11	170-506
5/16 x 3-1/4	171-639	9/16 x 1	173-699
5/16 x 3-1/2	173-748	9/16 x 1-1/4	173-700
5/16 x 4	170-293	9/16 x 1-1/2	173-701
5/16 x 4-1/2	170-294	9/16 x 2	172-219
5/16 x 5 (Grade 8)	172-983	5/8 x 1	171-087
5/16 x 5-1/2 (Grade 8)	172-952	5/8 x 1-1/4	171-366
3/8 x 3/4	170-439	5/8 x 1-1/2	170-153
3/8 x 3/4 (Stainless steel)	174-788	5/8 x 1-3/4 (Full thread)	170-030
3/8 x 7/8	170-268	5/8 x 2	170-009
3/8 x 1	170-054	5/8 x 2 (Full thread)	171-772
3/8 x 1-1/4	170-005	5/8 x 2-1/4	173-009
3/8 x 1-1/4 (Stainless steel)	174-917	5/8 x 2-1/2	172-381
3/8 x 1-1/2	170-368	5/8 x 2-1/2 (Full thread)	170-129
3/8 x 1-3/4	172-383	5/8 x 2-3/4	172-356
3/8 x 2	170-245	5/8 x 3	170-258
3/8 x 2-1/4	170-320	5/8 x 3-1/2	170-038
3/8 x 2-1/2	170-257	5/8 x 4	170-371
3/8 x 2-1/2 (Full thread)	170-128	5/8 x 4-1/2	170-067
3/8 x 2-1/2 (Lag)	171-775	5/8 x 5	170-065
3/8 x 3	170-380	5/8 x 5-1/2	172-421
3/8 x 3-1/2	170-292	5/8 x 6	170-381
3/8 x 4	170-877	5/8 x 6-1/2	173-777
3/8 x 4-1/4 (Black oxide)	171-813	5/8 x 7-1/2	173-019
3/8 x 4-1/2	170-519	5/8 x 9-1/2	171-039
3/8 x 5	170-493	3/4 x 1-1/2	173-507
3/8 x 5-1/2	174-196	3/4 x 2	171-768
3/8 x 5-1/2 (Full thread)	170-593	3/4 x 2 (Full thread)	170-058
3/8 x 6	174-304	3/4 x 2 (Grade 8)	171-877
3/8 x 6-1/2	171-291	3/4 x 2-1/4	171-275
3/8 x 7	172-587	3/4 x 2-1/2	170-374
7/16 x 3/4	170-265	3/4 x 2-1/2 (Grade 8)	175-055
7/16 x 1	170-032	3/4 x 3	170-014
7/16 x 1-1/4	170-354	3/4 x 3 UNF	173-776
7/16 x 1-1/4 (Grade 8)	174-216	3/4 x 3-1/2	170-195
7/16 x 1-1/2	170-059	3/4 x 3-1/2 (Grade 8)	171-899
7/16 x 2	170-356	3/4 x 4	170-419
7/16 x 2-1/2	170-379	3/4 x 4 (Grade 8) UNF	173-579
7/16 x 3	170-270	3/4 x 4-1/2	170-846
7/16 x 5-1/2	170-377	3/4 x 4-1/2 (Grade 8)	173-039
7/16 x 6	170-378	3/4 x 4-1/2 (Grade 8) UNF	173-588
1/2 x 3/4	171-252	3/4 x 5	173-508
1/2 x 1	170-149	3/4 x 5 UNF	173-510
1/2 x 1-1/4	170-373	3/4 x 5-1/2 (Grade 8) UNF	173-514
1/2 x 1-1/2	170-002	3/4 x 6	171-116
		3/4 x 6 UNF	173-511
		3/4 x 6 (Grade 8)	173-231
		3/4 x 6 1/2	176-148
		3/4 x 7	173-745
		3/4 x 7 UNF	173-747
		3/4 x 7-1/2	175-004
		3/4 x 8	173-509
		7/8 x 2-1/4	172-892
		7/8 x 2-1/2	175-633
		7/8 x 3	172-002
		7/8 x 3-1/2	173-020
		7/8 x 4	173-299
		7/8 x 4-1/2	175-953
		7/8 x 4 UNF	171-092
		7/8 x 6-1/2	173-774
		7/8 x 7	173-749
		7/8 x 7 UNF	174-097
		7/8 x 8	173-750
		7/8 x 8 UNF	173-515
		1 x 3-1/2	173-021
		1 x 4	175-119
		1 x 4 (Grade 8)	175-248
		1 x 7 UNF	173-516
		1 x 8	174-723
		1 x 8 (grade 8) UNF	173-713
		1-1/4 x 4-1/2 (grade 8)	175-003
		M8 x 16MM (Grade 8.8)	174-610
		M8 x 20MM (Grade 8.8)	175-193
		M8 x 25MM (Grade 8.8)	174-900
		M10 x 22MM (Grade 8.8)	175-016
		M10 x 25MM (Grade 8.8)	173-344
		M12 x 25MM (Grade 8.8)	171-566
		M12 x 35MM (Grade 8.8)	175-020
		M12 x 40MM (Grade 12.9)	175-190
		M12 x 45MM (Grade 10.9)	174-911
		M14 x 30MM (Grade 8.8)	173-518
		M16 x 40MM (Grade 8.8)	175-631
		M16 x 44MM (Grade 8.8)	175-634
		SOCKET HEAD CAP SCREW	
		3/8 x 7/8	172-044
		1/2 x 2-1/2	175-921
		SELF TAPPING SCREW	
		1/4 x 3/4	174-874
		CARRIAGE BOLTS	
		1/4 x 1-1/4 (Grade 2)	170-311
		1/4 x 1-1/2 (Grade 2)	170-355
		1/4 x 2 (Grade 2)	170-299
		1/4 x 2-1/2 (Grade 2)	171-394
		1/4 x 2-3/4 (Grade 2)	170-508
		1/4 x 3	170-509
		5/16 x 1 (Grade 2)	170-370
		5/16 x 1-1/2 (Grade 2)	170-296
		5/16 x 2-1/2 (Grade 2)	171-395
		5/16 x 5-1/2 (Grade 2)	170-494
		3/8 x 3-1/2 (Grade 2)	171-283
		3/8 x 4-1/2 (Grade 2)	170-191
		3/8 x 5 (Grade 2)	170-495
		3/8 x 6-1/2 (Grade 2)	171-174
		3/8 x 8 (Grade 2)	170-297
		3/8 x 13 (Grade 2)	170-298
		3/8 x 13-1/2 (Grade 2)	170-300
		1/2 x 1-1/2 (Grade 5)	174-918
		1/2 x 6-1/2 (Grade 2)	171-098
		1/2 x 9 (Grade 2)	171-255
		5/8 x 2	175-110
		5/8 x 2-1/2 (Grade 5)	174-790
		PLOW BOLTS	
		5/8 x 2	174-767
		3/4 x 2-1/2	174-948

Kuhn Knight, Inc.

1501 West 7th Ave., Brodhead, WI 53520
701 Cherry Ave., Greeley, CO 80632

Hardware Part Number Listing

TRUSS HEAD BOLTS

#6-32 x 3/4	172-416
#6-32 x 1	173-079
#8-32 x 1-1/2	171-210
#10-32 x 3/4	171-604
#10-32 x 1	172-882
1/4 x 3/4	170-193
1/4 x 1	170-194
5/16 x 1	170-117

SET SCREWS (Socket Head)(Cup Point)

1/4 x 1/4	170-247
1/4 x 5/8	172-985
5/16 x 1/4	170-993
5/16 x 5/16	170-248
5/16 x 5/16 UNF	170-825
5/16 x 3/8 UNF	173-367
5/16 x 1/2	170-254
5/16 x 5/8 UNF	170-456
5/16 x 1 (Sq hd)	173-610
5/16 x 1-1/2	172-917
3/8 x 1/4	170-856
3/8 x 3/8	170-151
3/8 x 1/2	170-857
3/8 x 1/2 UNF	171-469
3/8 x 3/4	174-190
3/8 x 3/4 (Sq hd)	170-290
3/8 x 1	170-021
3/8 x 1 (Sq hd)	173-609
3/8 x 1 (Sq hd) (Dog pt)	171-551
7/16 x 7/16	170-288
7/16 x 1 (Sq hd)	170-147
1/2 x 5/8	170-249
1/2 x 1	170-438
1/2 x 1-1/4 (half dog point)	171-085
5/8 x 5/8	170-250
3/4 x 3/4 (Sq hd) (Dog pt)	170-251

HEX NUTS

#6-32	172-418
#10-32	171-606
1/4	170-125
5/16	170-119
3/8	170-007
7/16	170-062
7/16 (Grade 8) UNF	174-217
1/2	170-004
9/16	173-702
5/8	170-011
3/4	170-017
3/4 UNF	170-159
3/4 (Grade 8) UNF	173-520
7/8	171-776
1	173-022
1 UNF	173-714
1 (Grade 8)	175-247
1 (Grade 8) UNF	173-519
1-1/8 UNF	174-095
1-1/4 UNF	170-130
1-1/4 (Grade 8)	175-006
M8 x 1.25MM	172-949
M30 x 1.5MM	174-902
M50 x 1.5MM	175-200

LOCK NUTS

#6-32	174-188
#10-32	174-073
1/4	170-069
5/16	170-137

3/8	170-047
7/16	170-239
1/2	170-042
1/2 UNF	170-566
1/2 (Grade 8)	171-671
9/16	172-220
5/8	170-031
3/4	170-185
3/4 (Grade 8)	171-900
3/4 (Grade 8) UNF	173-578
7/8	173-069
7/8 UNF	171-093
1	174-928
1 UNF	170-527
M45 x 1.5MM	175-199
M50 x 1.5MM	175-197

JAM NUTS

1/4UNF	171-386
5/16	173-521
3/8	170-022
7/16	170-046
1/2	170-036
1/2 Lock	174-063
5/8	170-037
3/4	170-035
1	174-927

FLAT WASHERS

#10	171-525
1/4	170-301
1/4 Heavy	171-083
1/4 Fender	173-672
5/16	170-127
5/16 Fender	173-811
3/8	170-244
3/8 Heavy	170-302
3/8 Aluminum	173-900
7/16	170-138
1/2	170-040
1/2 (Grade 8)	172-984
9/16	173-693
5/8	170-066
5/8 (Grade 8)	173-581
3/4	170-015
7/8	173-298
7/8 Heavy	170-131
1	170-122
1-1/4	170-928

LOCK WASHERS

#6	172-417
#10	171-605
1/4	170-124
5/16	170-118
3/8	170-006
7/16	170-061
1/2	170-003
9/16	173-692
5/8	170-010
3/4	170-016
3/4 External Tooth	174-793
7/8	172-003
1	171-021
1-1/4	175-005

ZERKS

1/8 NPT	170-865
---------	---------

1/8 NPT-45 Deg	170-864
1/8 NPT-65 Deg	170-215
1/8 NPT-90 Deg	170-866
3/16 drive in	174-124
1/4-28	170-023
1/4-28 - 45 Deg	170-148
1/4-28 - 90 Deg	170-049
1/4 NPT	170-277
1/4 NPT - 45 Deg	174-130

COTTER PINS

1/16 x 1/2	170-992
3/32 x 3/4	170-364
1/8 x 1	170-045
1/8 x 1-1/4	170-033
1/8 x 1-1/2	170-382
5/32 x 1	170-421
5/32 x 1-1/2	170-236
5/32 x 3	170-135
3/16 x 1-1/4	170-991
3/16 x 2	170-115
1/4 x 1-1/2	170-521
1/4 x 2	170-056
1/4 x 2-1/2	173-961

ROLLER CHAIN

CONNECTOR LINKS

#50	170-088
#50-2R	170-094
#60	170-089
#60-2R	170-095
#60H	171-102
#80	170-090
#80H	170-821
#80-2R	176-134
#100	170-091
#100H	171-969
#120	170-092
#140	170-093
#140H	173-552
#160	170-888

OFFSET LINKS

#50	170-096
#50-2R	170-102
#60	170-097
#60-2R	170-103
#60H	171-103
#80	170-098
#80H	170-820
#80-2R	176-135
#100	170-099
#100H	172-145
#120	170-100
#140	170-101
#140H	173-553
#160	170-887

ROLLER LINKS

#50	171-415
#60	171-416
#80	171-417
#80H	170-795
#100	171-418
#100H	172-146
#120	171-419
#140	171-420
#160	171-421

Part Number Index

101-707 ...11	134-351 ...11	170-478 ...7	171-955 ...9
101-708 ...11	134-366 ...5	170-490 ...28	171-960 ...23
101-709 ...11	134-409 ...23	170-499 ...9	171-998 ...19
101-741 ...21	134-499 ...11	170-521 ...15	172-006 ...7
101-756 ...15	134-701 ...27	170-627 ...9	172-018 ...24
101-788 ...9	134-703 ...27	170-720 ...24	172-019 ...24
101-791 ...19	134-704 ...27	170-800 ...7	172-024 ...7
101-817 ...7	134-705 ...27	170-812 ...28	172-128 ...22
101-818 ...7	134-706 ...27	170-813 ...28	172-130 ...22
101-821 ...16	134-707 ...27	170-844 ...21	172-136 ...23
101-822 ...16	134-708 ...27	170-849 ...28	172-139 ...21
101-835 ...5, 23	134-710 ...27	170-865 ...7, 21	172-143 ...23
101-848 ...15	134-740 ...11	170-893 ...28	172-165 ...23
101-862 ...11	134-756 ...5	170-898 ...5	172-166 ...23
101-876 ...21	134-758 ...11	170-984 ...21, 25	172-183 ...23
101-887 ...11	134-952 ...13	170-985 ...25	172-193 ...5
101-888 ...11	134-953 ...9	170-987 ...25	172-195 ...28
101-891 ...19	135-597 ...5	171-012 ...15	172-292 ...28
101-909 ...21, 28	135-701 ...11	171-030 ...14, 17	172-350 ...23
101-917 ...23	136-042 ...5	171-048 ...11	172-354 ...23
101-918 ...23	136-260 ...5	171-049 ...11	172-381 ...14
101-936 ...5	136-309 ...5	171-136 ...19	172-386 ...23
102-095 ...15	136-419 ...14	171-158 ...23	172-442 ...28
102-260 ...11	136-492 ...14	171-178 ...15	172-449 ...28
102-495 ...11	136-761 ...17, 18	171-346 ...15	172-500 ...22
102-496 ...11	136-762 ...21	171-380 ...23	172-784 ...19
102-499 ...26	136-764 ...14	171-409 ...5	172-800 ...22
102-501 ...21	136-907 ...7	171-430 ...19	172-801 ...22
102-502 ...26	136-908 ...7	171-464 ...17	172-802 ...22
102-503 ...12	136-990 ...21	171-535 ...21	172-803 ...22
102-504 ...21	140-849 ...9	171-550 ...24	172-804 ...22
102-505 ...17, 18	141-575 ...27	171-585 ...5	172-820 ...28
102-506 ...14	141-576 ...27	171-632 ...16	172-822 ...7
102-509 ...11	141-577 ...27	171-712 ...28	172-883 ...28
102-510 ...11	141-578 ...27	171-748 ...28	172-926 ...24
102-511 ...5	141-579 ...27	171-751 ...24	172-986 ...5, 24
102-513 ...11	141-580 ...27	171-753 ...24	173-040 ...28
102-772 ...23	141-581 ...27	171-754 ...24	173-044 ...28
103-052 ...23	141-582 ...27	171-755 ...24	173-156 ...23
104-081 ...9	141-597 ...26	171-756 ...24	173-164 ...5
104-373 ...15	141-608 ...18	171-799 ...24	173-211 ...23
104-581 ...9	143-147 ...5	171-817 ...21	173-212 ...23
130-785 ...15	143-384 ...15	171-820 ...28	173-213 ...23
131-011 ...11	170-000 ...11	171-825 ...21	173-214 ...23
132-988 ...23	170-004 ...18	171-827 ...21	173-215 ...23
133-376 ...5	170-005 ...18	171-829 ...21	173-216 ...23
133-445 ...14	170-008 ...5	171-830 ...21	173-217 ...23
133-831 ...11	170-047 ...18	171-832 ...21	173-218 ...23
133-832 ...11	170-056 ...21	171-833 ...21	173-219 ...23
133-833 ...11	170-069 ...24	171-911 ...28	173-225 ...22
133-849 ...5	170-073 ...14	171-913 ...28	173-226 ...22
133-852 ...5	170-074 ...14	171-915 ...28	173-227 ...22
133-853 ...5	170-075 ...14, 17	171-916 ...28	173-229 ...21
133-913 ...7	170-115 ...17, 18	171-919 ...5, 11	173-270 ...14, 17
133-920 ...5	170-120 ...15	171-920 ...11	173-427 ...24
133-921 ...5	170-142 ...5, 11	171-921 ...9	173-428 ...24
133-924 ...14	170-220 ...24	171-923 ...9	173-447 ...28
134-012 ...12, 26	170-235 ...14, 17, 19	171-924 ...9	173-448 ...28
134-112 ...11	170-238 ...5, 23	171-931 ...7	174-000 ...23
134-123 ...11	170-244 ...7, 18	171-934 ...5	174-001 ...23
134-136 ...19	170-366 ...28	171-935 ...5	174-002 ...23
134-155 ...7	170-386 ...25	171-936 ...23	174-003 ...23
134-161 ...16	170-415 ...23	171-947 ...28	174-004 ...23
134-235 ...15	170-465 ...19	171-948 ...28	174-501 ...22
134-242 ...15	170-468 ...14, 19	171-949 ...28	174-502 ...22
134-345 ...14, 15	170-471 ...14	171-954 ...9	174-503 ...22

Part Number Index

174-505 ...22	175-907 ...14
174-506 ...22	175-927 ...17
174-507 ...22	180-630 ...7
174-514 ...28	
174-551 ...28	
174-556 ...28	
174-558 ...11	
174-582 ...21	
174-583 ...21	
174-584 ...21	
174-585 ...21	
174-586 ...21	
174-587 ...21	
174-632 ...28	
174-653 ...7	
174-654 ...7	
174-675 ...28	
174-686 ...28	
174-719 ...23	
174-923 ...23	
174-926 ...23	
175-045 ...22	
175-046 ...23	
175-048 ...23	
175-049 ...23	
175-050 ...23	
175-051 ...23	
175-052 ...23	
175-074 ...22	
175-209 ...22	
175-210 ...22	
175-211 ...22	
175-212 ...22	
175-311 ...18	
175-312 ...18	
175-313 ...18	
175-387 ...5	
175-536 ...14, 17	
175-569 ...23	
175-574 ...22	
175-575 ...22	
175-576 ...22	
175-577 ...22	
175-578 ...22	
175-579 ...22	
175-582 ...23	
175-583 ...23	
175-595 ...22	
175-626 ...23	
175-627 ...23	
175-628 ...23	
175-673 ...14, 17	
175-675 ...14, 17	
175-686 ...14, 17	
175-687 ...14, 17	
175-757 ...28	
175-787 ...28	
175-788 ...28	
175-789 ...28	
175-799 ...28	
175-800 ...28	
175-820 ...28	
175-849 ...28	
175-871 ...28	
175-906 ...14	