

## TECHNICAL & SERVICE MANUAL

**CS-KS12NB41 & CZ-18BT1U + CU-KS12NK1A**  
**CS-KS18NB4UW & CZ-18BT1U + CU-KS18NKU**  
**CS-KS18NB4UW & CZ-18BT1U + CU-KS18NKUA**

## DC INVERTER SPLIT SYSTEM AIR CONDITIONER

Indoor Model No. Body (Panel)	Product Code No. Body (Panel)
CS-KS12NB41 (CZ-18BT1U)	1 852 361 04 (1 852 361 15)
CS-KS18NB4UW (CZ-18BT1U)	1 852 361 06 (1 852 361 15)

Outdoor Model No.	Product Code No.
CU-KS18NKU	1 852 361 18
CU-KS12NK1A	1 852 361 16
CU-KS18NKUA	1 852 361 19

Indoor Unit

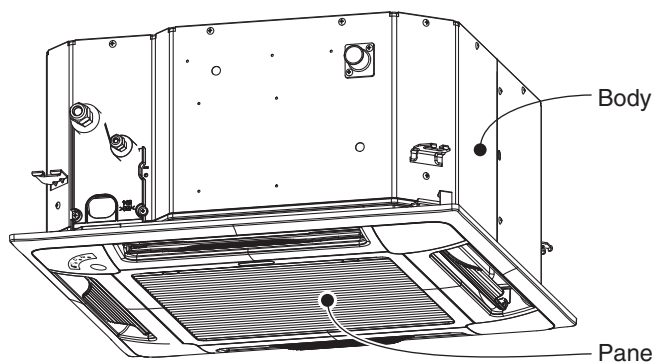

**CS-KS12NB41 (Body) & CZ-18BT1U (Panel)**  
**CS-KS18NB4UW (Body) & CZ-18BT1U (Panel)**

Outdoor Unit

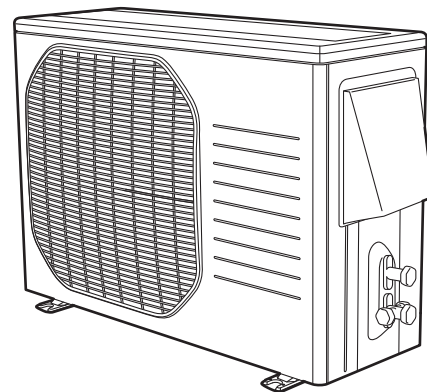

**CU-KS12NK1A**



Remote Controller





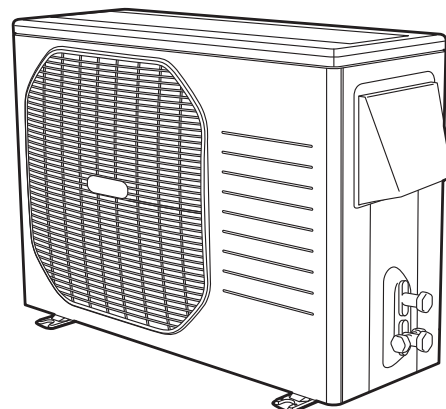





Wired Remote Controller  
(Option)

























**CU-KS18NKU**  
**CU-KS18NKUA**













**R410A**

# SAFETY PRECAUTIONS

- Before doing repair work, please read the " SAFETY PRECAUTIONS" carefully and fully understand them.
- The precautionary items here are divided into " Warning" and " Caution" items.  
Items in particular which may cause death or serious injury to the service personnel if the work is not performed correctly, are included in the " Warning" table.  
However, even precautionary items identified as " Caution" also have the potential for serious consequences if not performed correctly.  
Important safety precautions are described for all items in both categories. Be sure to carefully follow all of them.
- Symbol Indication
  -  : This symbol indicates items to which we need to pay attention.  
In this triangle, a definite precautionary item is described.
  -  : This symbol indicates the item to be prohibited.  
In or close to this circle, a prohibited item is described.
  -  : This symbol indicates the items requiring special attention or instruction.  
In or close to this circle, a prohibited item is described.
- After doing repair work, perform a test run to confirm that there are no abnormalities.  
At the same time, explain the precautions in use to the user.

 <b>Warning</b>	
Before performing an overhaul, disconnect the power plug or power cable from the unit. Performing the work with the power supplied to the unit, may cause an electric shock.	
When repair work or circuit inspection that requires power supply for the air conditioner, is to be performed, do not touch the charging section. Doing so may cause an electric shock.	 Prohibit
For the step-up capacitor attached to the electric section, perform the repair work after sufficiently discharging it. Insufficient capacitor discharge may cause an electric shock.	
Do not perform repair work on the electric sections with wet hands. Doing so may cause an electric shock.	 Prohibit
Do not start or stop the air conditioner by means of connecting or disconnecting the power plug. Doing so may cause an electric shock or fire.	 Prohibit
When conducting repair work only use components included in the parts list for the corresponding unit and perform the work with the appropriate tools. Incorrect or poor repair work may cause an electric shock or fire.	
Never modify the unit. Doing so may cause an electric shock or fire.	 Prohibit
Perform all electric work according to local applicable regulations related to electrical equipment or interior wiring regulation and make sure to use the exclusive circuit. Insufficient capacity to the electric circuit or defective arrangement results may cause an electric shock or fire.	
Make sure to replace any power cable or lead wire showing any signs of scratch or deterioration. Failure to do so may cause an electric shock, overheating or fire.	
Make sure that there is no dust on or slack in the power plug and insert fully into the socket. Dust or incomplete connections may cause an electric shock or fire.	
Do not damage or process the power cord, as it may cause an electric shock or fire.	 Prohibit
For the wiring between the indoor unit and outdoor unit, securely fix the specified cable onto the terminal plate. Poorly fixed wiring may cause a heat or fire.	
After connecting the wiring between the indoor unit and outdoor unit, attach the terminal cover securely. Incomplete attachment of the terminal cover may cause overheating or fire.	

 <b>Warning</b>	
If refrigerant gas blows off during the work, do not touch the refrigerant gas as it may cause frostbite.	 Prohibit
If refrigerant gas leaks during the work, ventilate the room. If refrigerant gas catches fire, harmful gas may be generated.	
Do not mix any gas other than the specified refrigerant gas in the refrigerating cycle. If air or other contaminants mix with the gas, pressure will become extremely high in the refrigerating cycle, which may cause a unit breakdown."	 Prohibit
When the welded section of the compressor intake or discharge pipe is to be disconnected, perform it in a well-ventilated place after sufficiently recovering the refrigerant gas. Any residue gas may jet out refrigerant or refrigerating machine oil, which may cause an injury.	
When the work is to be performed in a high place (About 2 meters or more), make sure to wear a safety helmet, gloves and safety belt. Insufficient safety gear may cause a serious injury in case of a fall.	
When the unit is to be relocated, confirm that the new installation location has sufficient strength for the weight of the unit. Insufficient strength of the installation location and incomplete installation work may cause an injury due to the unit falling.	
When the remote controller batteries are replaced, dispose of the old batteries out of the reach of children. If a child swallows a battery, make sure that the child gets immediate medical attention.	

 <b>Caution</b>	
Do not wash the air conditioner with water, as this may cause an electric shock or fire.	 Prohibit
For the repair work in places with high humidity or moisture, make sure to ground the unit. Failure to do so may cause an electric shock.	
Confirm that the component attachment position, wiring condition, soldering condition and connector connection are normal. If not, it may cause overheating or fire.	
Confirm that the temperature around the compressor is not too high, and then perform the repair work. Failure to do so may cause a burn.	
Perform welding work in a place with good ventilation. If the work is performed in a poorly ventilated area, it might cause a lack of oxygen.	
If the installation plate or attachment frame has deteriorated due to corrosion, etc., replace it. Failure to do so may cause an injury due to the unit falling.	
When the cleaning is to be performed, make sure to turn off the power and pull out the plug. Touching the fan that is rotating at high speed may result in an injury.	
When the indoor unit is to be removed, do not place it on an incline. Doing so may cause wet furniture because water left inside may trickle down.	 Prohibit
Do not hold the sharp end of the unit or the aluminum fins, as it may cause an injury to your hand or finger.	 Prohibit
After repairs, make sure to measure the insulation resistance and confirm that the value is 1 Mohm or more. Any insulation error may cause an electric shock.	
After repairs, make sure to check the drainage of the indoor unit. Inappropriate drainage may cause wet furniture and floors due to water leakage.	

# Table of Contents

	Page
<b>⚠ SAFETY PRECAUTIONS</b> .....	2
<b>TABLE OF CONTENTS</b> .....	4
<b>1. OPERATING RANGE</b> .....	6
<b>2. SPECIFICATIONS</b>	
2-1. Unit Specifications .....	7
2-2. Major Component Specifications .....	17
2-3. Other Component Specifications .....	22
<b>3. DIMENSIONAL DATA</b> .....	23
<b>4. REFRIGERANT FLOW DIAGRAM</b>	
4-1. Refrigerant Flow Diagram .....	26
<b>5. PERFORMANCE DATA</b>	
5-1. Temperature Charts .....	28
5-2. Cooling Capacity .....	30
5-3. Cooling Capacity (Low Ambient) .....	32
<b>6. ELECTRICAL DATA</b>	
6-1. Electrical Characteristics .....	34
6-2. Electric Wiring Diagrams .....	36
<b>7. MAINTENANCE</b>	
7-1. Address Setting of the Remote Control Unit .....	39
7-2. Disconnecting and Connecting Positive Connector for Outdoor Unit .....	40
7-3. Disassembly Procedure .....	41
<b>8. FUNCTIONS</b>	
8-1. Operation Functions .....	48
8-2. Protective Functions .....	50
<b>9. TROUBLESHOOTING (BEFORE CALLING FOR SERVICE)</b>	
9-1. Precautions before Performing Inspection or Repair .....	51
9-2. Method of Self-Diagnostics .....	51
9-3. Checking the Indoor and Outdoor Units .....	53
9-4. Trouble Diagnosis of Fan Motor .....	57
9-5. Noise Malfunction and Electromagnetic Interference .....	59

**10. CHECKING ELECTRICAL COMPONENTS**

10-1. Measurement of Insulation Resistance .....	60
10-2. Checking Continuity of Fuse on PCB Ass'y .....	61

**11. REFRIGERANT R410A:**

**SPECIAL PRECAUTIONS WHEN SERVICING UNIT**

11-1. Characteristics of New Refrigerant R410A .....	62
11-2. Checklist before Servicing .....	63
11-3. Tools Specifically for R410A .....	64
11-4. Tubing Installation Procedures .....	64
11-5. In Case of Compressor Malfunction .....	65
11-6. In Case Refrigerant is Leaking .....	67
11-7. Charging Additional Refrigerant .....	68
11-8. Retro-Fitting Existing Systems .....	68

<b>APPENDIX A</b> Operating Instructions .....	A-1
( CS-KS12NB41 & CZ-18BT1U + CU-KS12NK1A CS-KS18NB4UW & CZ-18BT1U + CU-KS18NKU CS-KS18NB4UW & CZ-18BT1U + CU-KS18NKUA )	

<b>APPENDIX B</b> INSTALLATION INSTRUCTIONS .....	A-2
( CS-KS12NB41 & CZ-18BT1U + CU-KS12NK1A CS-KS18NB4UW & CZ-18BT1U + CU-KS18NKU CS-KS18NB4UW & CZ-18BT1U + CU-KS18NKUA )	

<b>APPENDIX C</b> Operating Instructions .....	A-3
(CZ-RD515U)	

<b>APPENDIX D</b> INSTALLATION INSTRUCTIONS .....	A-4
(CZ-RD515U)	

# 1. OPERATING RANGE

**Models : CS-KS18NB4UW & CZ-18BT1U + CU-KS18NKU**

	Temperature	Indoor Air Intake Temp.	Outdoor Air Intake Temp.
Cooling	Maximum	95 °F DB / 71 °F WB	115 °F DB
	Minimum	67 °F DB / 57 °F WB	67 °F DB

**Models : CS-KS12NB41 & CZ-18BT1U + CU-KS12NK1A  
CS-KS18NB4UW & CZ-18BT1U + CU-KS18NKUA**

	Temperature	Indoor Air Intake Temp.	Outdoor Air Intake Temp.
Cooling	Maximum	95 °F DB / 71 °F WB	115 °F DB
	Minimum	67 °F DB / 57 °F WB	0 °F DB

## 2. SPECIFICATIONS

### 2-1. Unit Specifications

2-1-1. Indoor Unit **CS-KS18NB4UW & CZ-18BT1U**  
 Outdoor Unit **CU-KS18NKU**

< 230V >

Voltage Rating		230V Single-Phase 60Hz
Performance	Cooling	
	Total Capacity	BTU/h kW
	Sensible Capacity	BTU/h
	Latent Capacity	BTU/h
	Air Circulation (Hi/Me/Lo)	ft <sup>3</sup> /min (m <sup>3</sup> /h)
	Moisture Removal (High)	Pints/h
Electrical Rating	Available Voltage Range	V
	Running Amperes	A
	Power Input	W
	Power Factor	%
	EER	BTU/h/W
	SEER	BTU/Wh
	Compressor Locked Rotor Amperes	A
	Fuse or Circuit Breaker Capacity	A
Features	Controls / Temperature Control	
	Control Unit	
	Timer	
	Fan Speeds	Indoor / Outdoor
	Airflow Direction (Indoor)	Horizontal Vertical
	Air Filter	
	Compressor	
	Refrigerant / Amount charged at shipment	lbs (g)
	Refrigerant Control	
	Operation Sound	Indoor : Hi/Me/Lo Outdoor : Hi
	Refrigerant Tubing Connections	
	Max. allowable tubing length at shipment	ft (m)
	Refrigerant	Narrow tube Wide tube
	Tube Diameter	inch (mm)
	Wired Remote Controller (Option)	

Indoor Unit **CS-KS18NB4UW & CZ-18BT1U**  
 Outdoor Unit **CU-KS18NKU**

< 230V >

Dimensions & Weight (Indoor Unit)			Indoor Unit (CS-KS18NB4UW & CZ-18BT1U)	Individual Unit	
				Body (CS-KS18NB4UW)	Panel (CZ-18BT1U)
Unit Dimensions	Height	inch (mm)	12-5/16 (313)	11-5/32 (283)	1-9/16 (40)
	Width	inch (mm)	24-19/32 (625)	22-5/8 (575)	24-19/32 (625)
	Depth	inch (mm)	24-19/32 (625)	22-5/8 (575)	24-19/32 (625)
Package Dimensions	Height	inch (mm)	-	11-13/32 (290)	4-1/8 (105)
	Width	inch (mm)	-	24-13/16 (630)	26-3/16 (665)
	Depth	inch (mm)	-	28-1/8 (714)	26-11/16 (678)
Weight	Net	lb. (kg)	41.3 (18.7)	35.3 (16)	6.0 (2.7)
	Shipping	lb. (kg)	-	41.9 (19)	7.7 (3.5)
Shipping Volume		cu.ft (m <sup>3</sup> )	-	4.59 (0.13)	1.65 (0.04)

Dimensions & Weight (Outdoor Unit)			Outdoor Unit (CU-KS18NKU)
Unit Dimensions	Height	inch (mm)	26-3/8 (670)
	Width	inch (mm)	34-21/32 (880)
	Depth	inch (mm)	11-7/32 (285)
Package Dimensions	Height	inch (mm)	28-27/32 (733)
	Width	inch (mm)	39-27/32 (1,012)
	Depth	inch (mm)	14-29/32 (379)
Weight	Net	lb. (kg)	90.4 (41.0)
	Shipping	lb. (kg)	99.2 (45.0)
Shipping Volume		cu.ft (m <sup>3</sup> )	9.88 (0.28)

DATA SUBJECT TO CHANGE WITHOUT NOTICE.

**Remarks:** Rating conditions are:

Cooling: Indoor air temperature 80 °F DB / 67 °F WB

Outdoor air temperature 95 °F DB / 75 °F WB



**2-1-2. Indoor Unit CS-KS18NB4UW & CZ-18BT1U**  
**Outdoor Unit CU-KS18NKU**

< 208V >

<b>Voltage Rating</b>		208V Single-Phase 60Hz		
<b>Performance</b>			Cooling	
	Total Capacity	BTU/h	17,500 ( 4,000 to 17,500 )	
		kW	5.15 ( 1.2 to 5.15 )	
	Sensible Capacity	BTU/h	10,600	
	Latent Capacity	BTU/h	6,900	
	Air Circulation (Hi/Me/Lo)	ft <sup>3</sup> /min (m <sup>3</sup> /h)	341 (579) / 294 (500) / 253 (430)	
Moisture Removal (High)	Pints/h	4.89		
<b>Electrical Rating</b>	Available Voltage Range	V	187 to 253	
	Running Amperes	A	9.1 ( 1.2 to 9.1 )	
	Power Input	W	1,860 ( 250 to 1,860 )	
	Power Factor	%	98	
	EER	BTU/h/W	9.41	
	SEER	BTU/Wh	16	
	Compressor Locked Rotor Amperes	A	17.5	
	Fuse or Circuit Breaker Capacity	A	15	
<b>Features</b>	Controls / Temperature Control		Microprocessor / I.C. Thermister	
	Control Unit		Wireless Remote Control Unit	
	Timer		24-Hour ON or OFF Timer, 1-Hour OFF Timer	
	Fan Speeds	Indoor / Outdoor	Auto and 3 steps / Auto (Hi, Me, Lo)	
	Airflow Direction (Indoor)	Horizontal	-	
		Vertical	Auto	
	Air Filter		Washable, Anti-Mold	
	Compressor		DC Twin Rotary (Inverter)	
	Refrigerant / Amount charged at shipment	lbs (g)	R410A / 2.87 (1,300)	
	Refrigerant Control		Electric Expansion Valve	
	Operation Sound	Indoor : Hi/Me/Lo	dB-A	44 / 40 / 36
		Outdoor : Hi	dB-A	51
	Refrigerant Tubing Connections		Flare Type	
	Max. allowable tubing length at shipment	ft (m)	25 (7.5)	
	Refrigerant	Narrow tube	inch (mm)	1/4 (6.35)
	Tube Diameter	Wide tube	inch (mm)	1/2 (12.7)
Wired Remote Controller (Option)			CZ-RD515U	

Indoor Unit **CS-KS18NB4UW & CZ-18BT1U**  
 Outdoor Unit **CU-KS18NKU**

< 208V >

Dimensions & Weight (Indoor Unit)			Indoor Unit (CS-KS18NB4UW & CZ-18BT1U)	Individual Unit	
				Body (CS-KS18NB4UW)	Panel (CZ-18BT1U)
Unit Dimensions	Height	inch (mm)	12-5/16 (313)	11-5/32 (283)	1-9/16 (40)
	Width	inch (mm)	24-19/32 (625)	22-5/8 (575)	24-19/32 (625)
	Depth	inch (mm)	24-19/32 (625)	22-5/8 (575)	24-19/32 (625)
Package Dimensions	Height	inch (mm)	-	11-13/32 (290)	4-1/8 (105)
	Width	inch (mm)	-	24-13/16 (630)	26-3/16 (665)
	Depth	inch (mm)	-	28-1/8 (714)	26-11/16 (678)
Weight	Net	lb. (kg)	41.3 (18.7)	35.3 (16)	6.0 (2.7)
	Shipping	lb. (kg)	-	41.9 (19)	7.7 (3.5)
Shipping Volume		cu.ft (m <sup>3</sup> )	-	4.59 (0.13)	1.65 (0.04)

Dimensions & Weight (Outdoor Unit)			Outdoor Unit (CU-KS18NKU)
Unit Dimensions	Height	inch (mm)	26-3/8 (670)
	Width	inch (mm)	34-21/32 (880)
	Depth	inch (mm)	11-7/32 (285)
Package Dimensions	Height	inch (mm)	28-27/32 (733)
	Width	inch (mm)	39-27/32 (1,012)
	Depth	inch (mm)	14-29/32 (379)
Weight	Net	lb. (kg)	90.4 (41.0)
	Shipping	lb. (kg)	99.2 (45.0)
Shipping Volume		cu.ft (m <sup>3</sup> )	9.88 (0.28)

DATA SUBJECT TO CHANGE WITHOUT NOTICE.

**Remarks:** Rating conditions are:

Cooling: Indoor air temperature 80 °F DB / 67 °F WB

Outdoor air temperature 95 °F DB / 75 °F WB

**2-1-3. Indoor Unit CS-KS12NB41 & CZ-18BT1U**  
**Outdoor Unit CU-KS12NK1A**

<b>Voltage Rating</b>		115V Single-Phase 60Hz
<b>Performance</b>	Cooling	
	Total Capacity	BTU/h kW
	Sensible Capacity	BTU/h
	Latent Capacity	BTU/h
	Air Circulation (Hi/Me/Lo)	ft <sup>3</sup> /min (m <sup>3</sup> /h)
	Moisture Removal (High)	Pints/h
<b>Electrical Rating</b>	Available Voltage Range	V
	Running Amperes	A
	Power Input	W
	Power Factor	%
	EER	BTU/h/W
	SEER	BTU/Wh
	Compressor Locked Rotor Amperes	A
	Fuse or Circuit Breaker Capacity	A
<b>Features</b>	Controls / Temperature Control	
	Control Unit	
	Timer	
	Fan Speeds	Indoor / Outdoor
	Airflow Direction (Indoor)	Horizontal
		Vertical
	Air Filter	
	Compressor	
	Refrigerant / Amount charged at shipment	lbs (g)
	Refrigerant Control	
	Operation Sound	Indoor : Hi/Me/Lo Outdoor : Hi
		dB-A dB-A
	Refrigerant Tubing Connections	
	Max. allowable tubing length at shipment	ft (m)
	Refrigerant	Narrow tube Wide tube
Tube Diameter	inch (mm) inch (mm)	
Wired Remote Controller (Option)		

Indoor Unit **CS-KS12NB41 & CZ-18BT1U**  
 Outdoor Unit **CU-KS12NK1A**

Dimensions & Weight (Indoor Unit)			Indoor Unit (CS-KS12NB41 & CZ-18BT1U)	Individual Unit	
				Body (CS-KS12NB41)	Panel (CZ-18BT1U)
Unit Dimensions	Height	inch (mm)	12-5/16 (313)	11-5/32 (283)	1-9/16 (40)
	Width	inch (mm)	24-19/32 (625)	22-5/8 (575)	24-19/32 (625)
	Depth	inch (mm)	24-19/32 (625)	22-5/8 (575)	24-19/32 (625)
Package Dimensions	Height	inch (mm)	-	11-13/32 (290)	4-1/8 (105)
	Width	inch (mm)	-	24-13/16 (630)	26-3/16 (665)
	Depth	inch (mm)	-	28-1/8 (714)	26-11/16 (678)
Weight	Net	lb. (kg)	41.3 (18.7)	35.3 (16)	6.0 (2.7)
	Shipping	lb. (kg)	-	41.9 (19)	7.7 (3.5)
Shipping Volume		cu.ft (m <sup>3</sup> )	-	4.59 (0.13)	1.65 (0.04)

Dimensions & Weight (Outdoor Unit)			Outdoor Unit (CU-KS12NK1A)
Unit Dimensions	Height	inch (mm)	21-9/16 (548)
	Width	inch (mm)	28-11/32 (720)
	Depth	inch (mm)	10-7/16 (265)
Package Dimensions	Height	inch (mm)	23-15/32 (596)
	Width	inch (mm)	34-3/32 (866)
	Depth	inch (mm)	14-1/2 (368)
Weight	Net	lb. (kg)	75.0 (34.0)
	Shipping	lb. (kg)	81.6 (37.0)
Shipping Volume		cu.ft (m <sup>3</sup> )	6.35 (0.18)

DATA SUBJECT TO CHANGE WITHOUT NOTICE.

**Remarks:** Rating conditions are:  
 Cooling: Indoor air temperature 80 °F DB / 67 °F WB  
 Outdoor air temperature 95 °F DB / 75 °F WB

**2-1-4. Indoor Unit CS-KS18NB4UW & CZ-18BT1U**  
**Outdoor Unit CU-KS18NKUA**

< 230V >

<b>Voltage Rating</b>		230V Single-Phase 60Hz		
<b>Performance</b>			Cooling	
	Total Capacity	BTU/h kW	17,500 ( 4,000 to 17,500 ) 5.15 ( 1.2 to 5.15 )	
	Sensible Capacity	BTU/h	10,600	
	Latent Capacity	BTU/h	6,900	
	Air Circulation (Hi/Me/Lo)	ft <sup>3</sup> /min (m <sup>3</sup> /h)	341 (579) / 294 (500) / 253 (430)	
	Moisture Removal (High)	Pints/h	4.89	
<b>Electrical Rating</b>	Available Voltage Range	V	187 to 253	
	Running Amperes	A	8.3 ( 1.2 to 8.3 )	
	Power Input	W	1,860 ( 250 to 1,860 )	
	Power Factor	%	97	
	EER	BTU/h/W	9.41	
	SEER	BTU/Wh	16	
	Compressor Locked Rotor Amperes	A	17.5	
	Fuse or Circuit Breaker Capacity	A	15	
<b>Features</b>	Controls / Temperature Control		Microprocessor / I.C. Thermister	
	Control Unit		Wireless Remote Control Unit	
	Timer		24-Hour ON or OFF Timer, 1-Hour OFF Timer	
	Fan Speeds	Indoor / Outdoor	Auto and 3 steps / Auto (Hi and multi steps)	
	Airflow Direction (Indoor)	Horizontal	-	
		Vertical	Auto	
	Air Filter		Washable, Anti-Mold	
	Compressor		DC Twin Rotary (Inverter)	
	Refrigerant / Amount charged at shipment	lbs (g)	R410A / 2.87 (1,300)	
	Refrigerant Control		Electric Expansion Valve	
	Operation Sound	Indoor : Hi/Me/Lo	dB-A	44 / 40 / 36
		Outdoor : Hi	dB-A	51
	Refrigerant Tubing Connections		Flare Type	
	Max. allowable tubing length at shipment	ft (m)	25 (7.5)	
	Refrigerant	Narrow tube	inch (mm)	1/4 (6.35)
Wide tube		inch (mm)	1/2 (12.7)	
Wired Remote Controller (Option)		CZ-RD515U		

Indoor Unit **CS-KS18NB4UW & CZ-18BT1U**  
 Outdoor Unit **CU-KS18NKUA**

< 230V >

Dimensions & Weight (Indoor Unit)			Indoor Unit (CS-KS18NB4UW & CZ-18BT1U)	Individual Unit	
				Body (CS-KS18NB4UW)	Panel (CZ-18BT1U)
Unit Dimensions	Height	inch (mm)	12-5/16 (313)	11-5/32 (283)	1-9/16 (40)
	Width	inch (mm)	24-19/32 (625)	22-5/8 (575)	24-19/32 (625)
	Depth	inch (mm)	24-19/32 (625)	22-5/8 (575)	24-19/32 (625)
Package Dimensions	Height	inch (mm)	-	11-13/32 (290)	4-1/8 (105)
	Width	inch (mm)	-	24-13/16 (630)	26-3/16 (665)
	Depth	inch (mm)	-	28-1/8 (714)	26-11/16 (678)
Weight	Net	lb. (kg)	41.3 (18.7)	35.3 (16)	6.0 (2.7)
	Shipping	lb. (kg)	-	41.9 (19)	7.7 (3.5)
Shipping Volume		cu.ft (m <sup>3</sup> )	-	4.59 (0.13)	1.65 (0.04)

Dimensions & Weight (Outdoor Unit)			Outdoor Unit (CU-KS18NKUA)
Unit Dimensions	Height	inch (mm)	26-3/8 (670)
	Width	inch (mm)	34-21/32 (880)
	Depth	inch (mm)	11-7/32 (285)
Package Dimensions	Height	inch (mm)	28-27/32 (733)
	Width	inch (mm)	39-27/32 (1,012)
	Depth	inch (mm)	14-29/32 (379)
Weight	Net	lb. (kg)	90.4 (41.0)
	Shipping	lb. (kg)	99.2 (45.0)
Shipping Volume		cu.ft (m <sup>3</sup> )	9.88 (0.28)

DATA SUBJECT TO CHANGE WITHOUT NOTICE.

**Remarks:** Rating conditions are:

Cooling: Indoor air temperature 80 °F DB / 67 °F WB

Outdoor air temperature 95 °F DB / 75 °F WB

**2-1-5. Indoor Unit CS-KS18NB4UW & CZ-18BT1U**  
**Outdoor Unit CU-KS18NKUA**

< 208V >

<b>Voltage Rating</b>		208V Single-Phase 60Hz
<b>Performance</b>	Cooling	
	Total Capacity	BTU/h kW
	Sensible Capacity	BTU/h
	Latent Capacity	BTU/h
	Air Circulation (Hi/Me/Lo)	ft <sup>3</sup> /min (m <sup>3</sup> /h)
	Moisture Removal (High)	Pints/h
<b>Electrical Rating</b>	Available Voltage Range	V
	Running Amperes	A
	Power Input	W
	Power Factor	%
	EER	BTU/h/W
	SEER	BTU/Wh
	Compressor Locked Rotor Amperes	A
	Fuse or Circuit Breaker Capacity	A
<b>Features</b>	Controls / Temperature Control	
	Control Unit	
	Timer	
	Fan Speeds	Indoor / Outdoor
	Airflow Direction (Indoor)	Horizontal
		Vertical
	Air Filter	
	Compressor	
	Refrigerant / Amount charged at shipment	lbs (g)
	Refrigerant Control	
	Operation Sound	Indoor : Hi/Me/Lo Outdoor : Hi
	Refrigerant Tubing Connections	
	Max. allowable tubing length at shipment	ft (m)
	Refrigerant	Narrow tube Wide tube
	Tube Diameter	inch (mm)
Wired Remote Controller (Option)		

Indoor Unit **CS-KS18NB4UW & CZ-18BT1U**  
 Outdoor Unit **CU-KS18NKUA**

< 208V >

Dimensions & Weight (Indoor Unit)			Indoor Unit (CS-KS18NB4UW & CZ-18BT1U)	Individual Unit	
				Body (CS-KS18NB4UW)	Panel (CZ-18BT1U)
Unit Dimensions	Height	inch (mm)	12-5/16 (313)	11-5/32 (283)	1-9/16 (40)
	Width	inch (mm)	24-19/32 (625)	22-5/8 (575)	24-19/32 (625)
	Depth	inch (mm)	24-19/32 (625)	22-5/8 (575)	24-19/32 (625)
Package Dimensions	Height	inch (mm)	-	11-13/32 (290)	4-1/8 (105)
	Width	inch (mm)	-	24-13/16 (630)	26-3/16 (665)
	Depth	inch (mm)	-	28-1/8 (714)	26-11/16 (678)
Weight	Net	lb. (kg)	41.3 (18.7)	35.3 (16)	6.0 (2.7)
	Shipping	lb. (kg)	-	41.9 (19)	7.7 (3.5)
Shipping Volume		cu.ft (m <sup>3</sup> )	-	4.59 (0.13)	1.65 (0.04)

Dimensions & Weight (Outdoor Unit)			Outdoor Unit (CU-KS18NKUA)
Unit Dimensions	Height	inch (mm)	26-3/8 (670)
	Width	inch (mm)	34-21/32 (880)
	Depth	inch (mm)	11-7/32 (285)
Package Dimensions	Height	inch (mm)	28-27/32 (733)
	Width	inch (mm)	39-27/32 (1,012)
	Depth	inch (mm)	14-29/32 (379)
Weight	Net	lb. (kg)	90.4 (41.0)
	Shipping	lb. (kg)	99.2 (45.0)
Shipping Volume		cu.ft (m <sup>3</sup> )	9.88 (0.28)

DATA SUBJECT TO CHANGE WITHOUT NOTICE.

**Remarks:** Rating conditions are:

Cooling: Indoor air temperature 80 °F DB / 67 °F WB

Outdoor air temperature 95 °F DB / 75 °F WB



## 2-2. Major Component Specifications

### 2-2-1. Indoor Unit

Indoor Unit (Body) **CS-KS12NB41**

<b>Control PCB</b>	
Part No.	CB-CS-KS12NB4U
Controls	Microprocessor
Control Circuit Fuse	250V 3A

<b>Fan</b>	
Type	Turbo
Q'ty ... Dia. and Length	inch (mm) 1 ... D12-5/8 / L5-3/4 (D322/L147)

<b>Fan Motor</b>	
Type	DC Motor
Model ... Q'ty	SIC-62FW-D866-2 ... 1
No. of Poles	8
Rough Measure RPM (Cool)	470
Rating	Voltage / Nominal Output DC160V / 23W
Coil Resistance (Ambient Temp. 68 °F (20 °C))	Ohm -
Safety Device	Internal Controller
Type	Over- Current Protection
	Yes
	Over- Heat Protection
	Yes
Run Capacitor	Micro F -
	VAC -

<b>Drain Pump</b>	
Model ... Q'ty	PLD-12115ST-1 ... 1
Rating	Voltage, Hz AC115V, 60Hz
	Input W 10.8
Coil Resistance (Ambient Temp. 68 °F (20 °C))	Ohm 101 +/- 10%
Safety Device	Type Thermal Fuse
	Open °F (°C) 293 (145)

<b>Heat Exchanger Coil</b>	
Coil	Aluminum Plate Fin / Copper Tube
Rows	2
Fins per inch	18.1
Face Area	ft <sup>2</sup> (m <sup>2</sup> ) 2.94 (0.273)

DATA SUBJECT TO CHANGE WITHOUT NOTICE.

Indoor Unit (Panel) **CZ-18BT1U**

<b>Flap Motor</b>	
Type	Stepping Motor
Model ... Q'ty	MP24ZN-12V ... 2
Rating	DC 12V
Coil Resistance (Ambient Temp. 77 °F (25 °C))	Ohm Each Pair of Terminal : 380 +/- 7%

DATA SUBJECT TO CHANGE WITHOUT NOTICE.

Indoor Unit (Body) **CS-KS18NB4UW**

<b>Control PCB</b>		
Part No.		CB-CS-KS18NB4U
Controls		Microprocessor
Control Circuit Fuse		250V 3A

<b>Fan</b>		
Type		Turbo
Q'ty ... Dia. and Length	inch (mm)	1 ... D12-5/8 / L5-3/4 (D322/L147)

<b>Fan Motor</b>		
Type		DC Motor
Model ... Q'ty		SIC-62FW-D866-2 ... 1
No. of Poles		8
Rough Measure RPM (Cool)		650
Rating	Voltage / Nominal Output	DC340V / 20W
Coil Resistance	Ohm (Ambient Temp. 68 °F (20 °C))	-
Safety Device	Type	Internal Controller
	Over- Current Protection	Yes
	Over- Heat Protection	Yes
Run Capacitor	Micro F VAC	- -

<b>Drain Pump</b>		
Model ... Q'ty		PLD-12230ST-1 ... 1
Rating	Voltage, Hz Input W	AC208 to 240V, 60Hz 10.8
Coil Resistance	Ohm (Ambient Temp. 68 °F (20 °C))	333 +/- 10%
Safety Device	Type Open °F (°C)	Thermal Fuse 293 (145)

<b>Heat Exchanger Coil</b>		
Coil		Aluminum Plate Fin / Copper Tube
Rows		2
Fins per inch		18.1
Face Area	ft <sup>2</sup> (m <sup>2</sup> )	2.94 (0.273)

DATA SUBJECT TO CHANGE WITHOUT NOTICE.

Indoor Unit (Panel) **CZ-18BT1U**

<b>Flap Motor</b>		
Type		Stepping Motor
Model ... Q'ty		MP24ZN-12V ... 2
Rating		DC 12V
Coil Resistance	Ohm (Ambient Temp. 77 °F (25 °C))	Each Pair of Terminal : 380 +/- 7%

DATA SUBJECT TO CHANGE WITHOUT NOTICE.

## 2-2-2. Outdoor Unit

Outdoor Unit **CU-KS18NKU**

<b>Control PCB</b>	
Part No.	CB-CU-KS18NKU
Controls	Microprocessor
Control Circuit Fuse	250V 25A

<b>Compressor</b>	
Type	DC Twin Rotary (Hermetic)
Compressor Model / Nominal Output	C-6RVN93H0M / 1,050W
Compressor Oil ... Amount	Pints (cc) FV50S ... 0.74 (350)
Coil Resistance (Ambient Temp. 68 °F (20 °C))	Ohm R - S : 0.482 S - T : 0.482 T - R : 0.482
Safety Device	
CT (Peak current cut-off control)	Yes
Compressor Discharge Temp. Control	Yes
Operation cut-off control in abnormal ambient Temp.	Yes
Overload Relay	Model CS-7L115
	Operation Temp. Open : 239 °F (115 °C), Close : 203 °F (95 °C)
Run Capacitor	Micro F -
	VAC -
Crankcase Heater	-

<b>Fan</b>	
Type	Propeller
Q'ty ... Dia.	inch (mm) 1 ... D16-17/32 (D420)

<b>Fan Motor</b>	
Type	DC Motor
Model ... Q'ty	SIC-67FV-F460-1 ... 1
No. of Poles	8
Rough Measure RPM (Cool)	820
Nominal Output	W 50
Coil Resistance	Ohm RED - WHT : 77.5 WHT - BLU : 77.5 BLU - RED : 77.5
(Ambient Temp. 68 °F (20 °C))	
Safety Device	
Type	Internal Controller
Over- Current Protection	Yes
Run Capacitor	Micro F -
	VAC -

<b>Heat Exchanger Coil</b>	
Coil	Aluminum Plate Fin / Copper Tube
Rows	2
Fins per inch	21.2
Face Area	ft <sup>2</sup> (m <sup>2</sup> ) 5.49 (0.510)

<b>External Finish</b>	Acrylic baked-on enamel finish
------------------------	--------------------------------

DATA SUBJECT TO CHANGE WITHOUT NOTICE.

Outdoor Unit **CU-KS12NK1A**

<b>Control PCB</b>	
Part No.	CB-CU-KS12NK1A
Controls	Microprocessor
Control Circuit Fuse	125V 25A

<b>Compressor</b>	
Type	DC Rotary (Hermetic)
Compressor Model / Nominal Output	G4C090LU1ER / 900W
Compressor Oil ... Amount	Pints (cc) FV50S ... 0.68 (320)
Coil Resistance (Ambient Temp. 68 °F (20 °C))	Ohm U - V : 0.81 V - W : 0.81 W - U : 0.81
Safety Device	
CT (Peak current cut-off control)	Yes
Compressor Discharge Temp. Control	Yes
Operation cut-off control in abnormal ambient Temp.	Yes
Overload Relay	Model CS-7L115
	Operation Temp. Open : 239 °F (115 °C), Close : 203 °F (95 °C)
Run Capacitor	Micro F -
	VAC -
Crankcase Heater	115V 20W

<b>Fan</b>	
Type	Propeller
Q'ty ... Dia.	inch (mm) 1 ... D15-3/4 (D400)

<b>Fan Motor</b>	
Type	DC Motor
Model ... Q'ty	SIC-67FV-F460-1 ... 1
No. of Poles	8
Rough Measure RPM (Cool)	750
Nominal Output	W 50
Coil Resistance	Ohm RED - WHT : 77.5 WHT - BLU : 77.5 BLU - RED : 77.5
(Ambient Temp. 68 °F (20 °C))	
Safety Device	
Type	Internal Controller
Over- Current Protection	Yes
Run Capacitor	Micro F -
	VAC -

<b>Heat Exchanger Coil</b>	
Coil	Aluminum Plate Fin / Copper Tube
Rows	2
Fins per inch	18.1
Face Area	ft <sup>2</sup> (m <sup>2</sup> ) 3.95 (0.367)

<b>External Finish</b>	
	Acrylic baked-on enamel finish

DATA SUBJECT TO CHANGE WITHOUT NOTICE.

Outdoor Unit **CU-KS18NKUA**

<b>Control PCB</b>	
Part No.	CB-CU-KS18NKUA
Controls	Microprocessor
Control Circuit Fuse	250V 25A

<b>Compressor</b>	
Type	DC Twin Rotary (Hermetic)
Compressor Model / Nominal Output	C-6RVN93H0M / 1,050W
Compressor Oil ... Amount	Pints (cc) FV50S ... 0.74 (350)
Coil Resistance (Ambient Temp. 68 °F (20 °C))	Ohm R - S : 0.482 S - T : 0.482 T - R : 0.482
Safety Device	
CT (Peak current cut-off control)	Yes
Compressor Discharge Temp. Control	Yes
Operation cut-off control in abnormal ambient Temp.	Yes
Overload Relay	Model CS-7L115
	Operation Temp. Open : 239 °F (115 °C), Close : 203 °F (95 °C)
Run Capacitor	Micro F -
	VAC -
Crankcase Heater	-

<b>Fan</b>	
Type	Propeller
Q'ty ... Dia.	inch (mm) 1 ... D16-17/32 (D420)

<b>Fan Motor</b>	
Type	DC Motor
Model ... Q'ty	SIC-67FV-F460-1 ... 1
No. of Poles	8
Rough Measure RPM (Cool)	820
Nominal Output	W 50
Coil Resistance	Ohm RED - WHT : 77.5 WHT - BLU : 77.5 BLU - RED : 77.5
(Ambient Temp. 68 °F (20 °C))	
Safety Device	
Type	Internal Controller
Over- Current Protection	Yes
Run Capacitor	Micro F -
	VAC -

<b>Heat Exchanger Coil</b>	
Coil	Aluminum Plate Fin / Copper Tube
Rows	2
Fins per inch	21.2
Face Area	ft <sup>2</sup> (m <sup>2</sup> ) 5.49 (0.510)

<b>External Finish</b>	
	Acrylic baked-on enamel finish

DATA SUBJECT TO CHANGE WITHOUT NOTICE.

## 2-3. Other Component Specifications

Indoor Unit **CS-KS12NB41 & CZ-18BT1U**  
**CS-KS18NB4UW & CZ-18BT1U**

Outdoor Unit **CU-KS18NKU**  
**CU-KS12NK1A CU-KS18NKUA**

- **Indoor air temp sensor**  
 (Model:KTEC-35-S98)

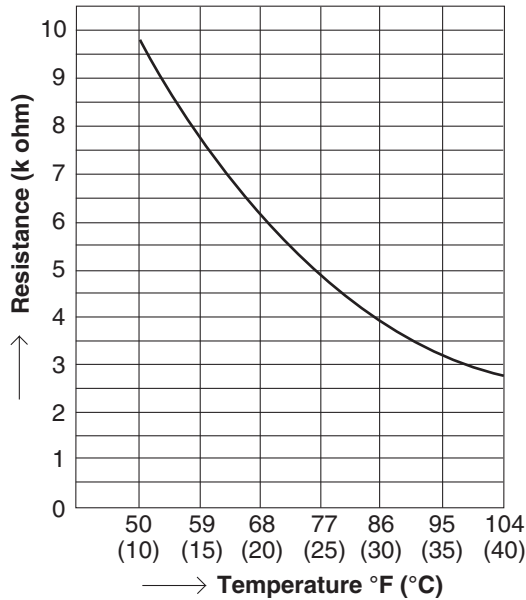

- **Indoor heat exchanger sensor**  
 (Model:PT2M-51H-S3)
- **Compressor temp sensor**  
 (CU-KS12NK1A...Model:DTN-TKS274Y TH2)  
 (CU-KS18NKU , CU-KS18NKUA...Model:DTN-TKS293B)

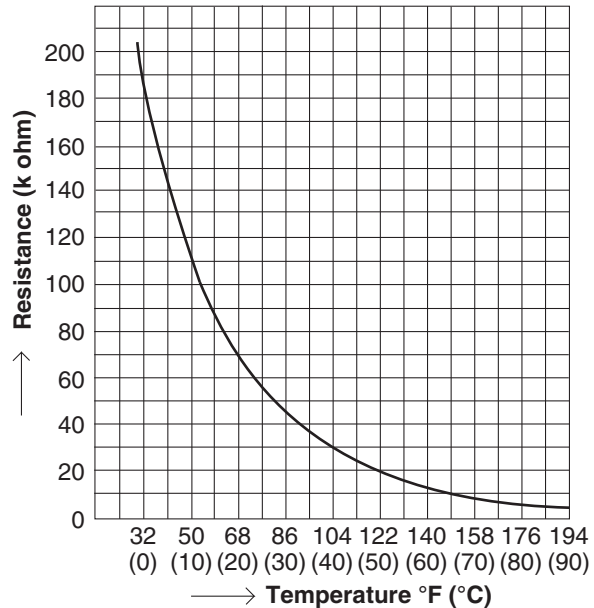

- **Outdoor air temp sensor**  
 (CU-KS12NK1A...Model:DTN-TKS269B)  
 (CU-KS18NKU , CU-KS18NKUA...Model:TKS295B)
- **Outdoor heat exchanger sensor**  
 (CU-KS12NK1A...Model:DTN-TKS274Y TH1)  
 (CU-KS18NKU , CU-KS18NKUA...Model:TKS292B)

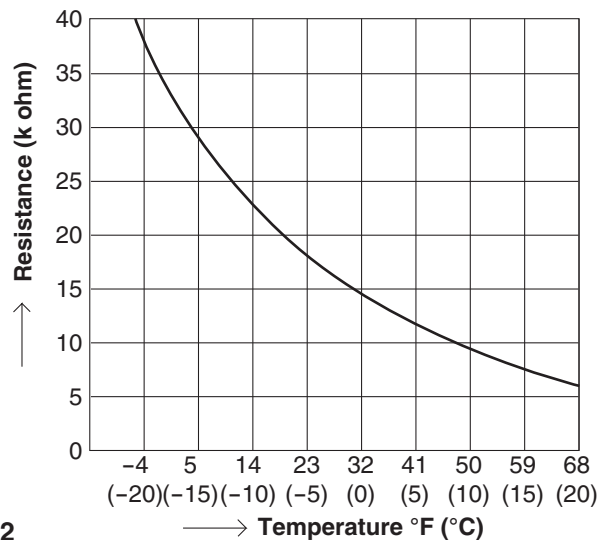

# 3. DIMENSIONAL DATA

Indoor Unit **CS-KS12NB41 & CZ-18BT1U**  
**CS-KS18NB4UW & CZ-18BT1U**

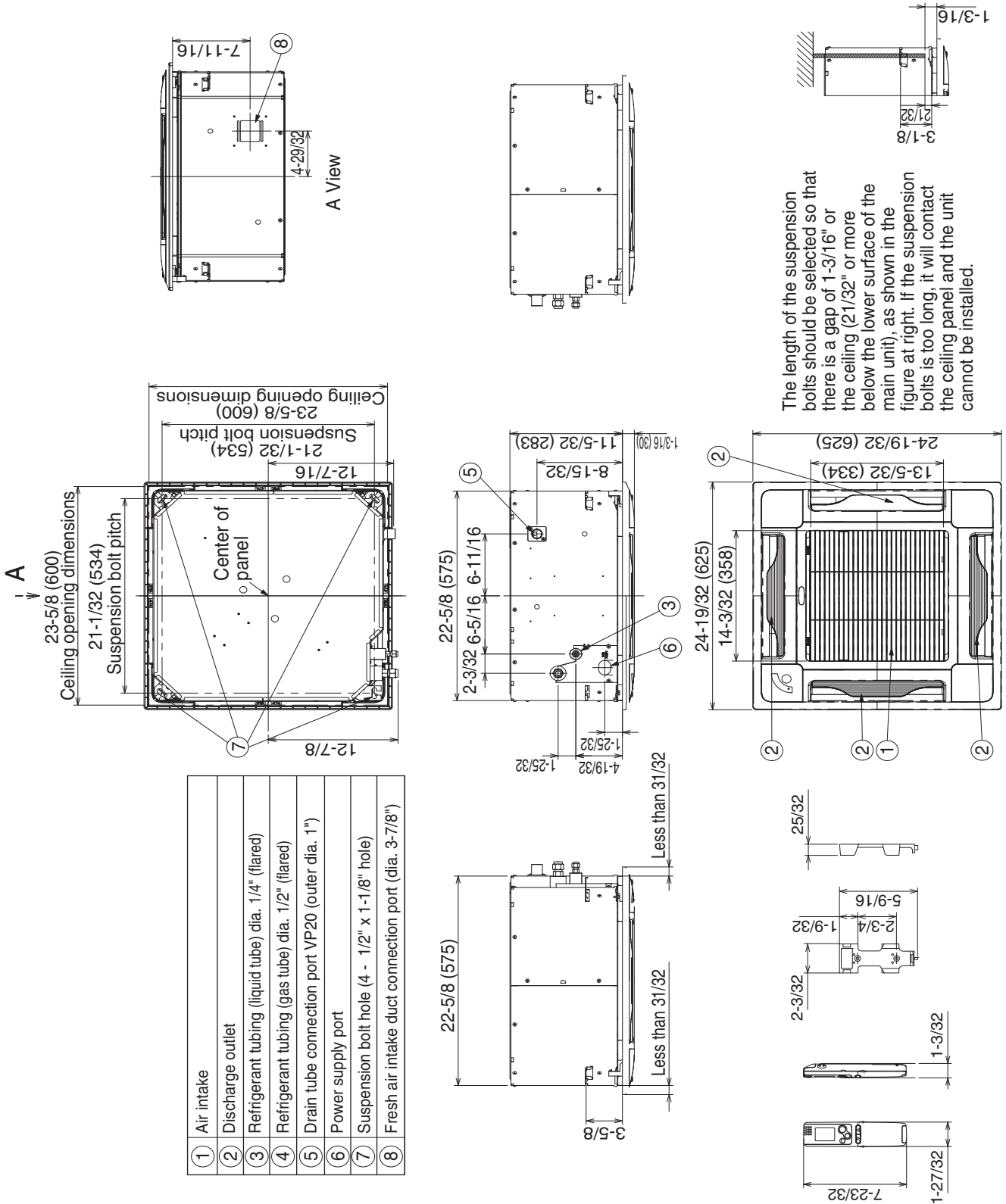

Unit : inch (mm)

Outdoor Unit **CU-KS12NK1A**

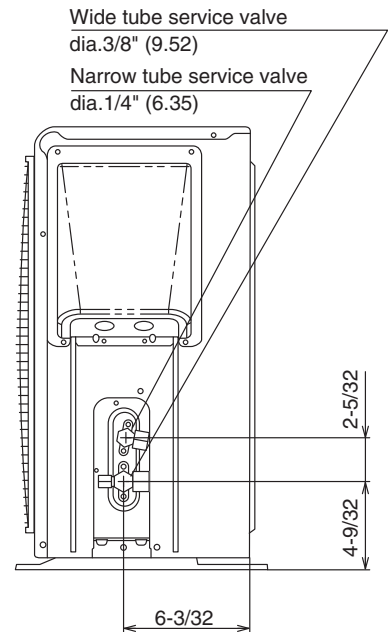
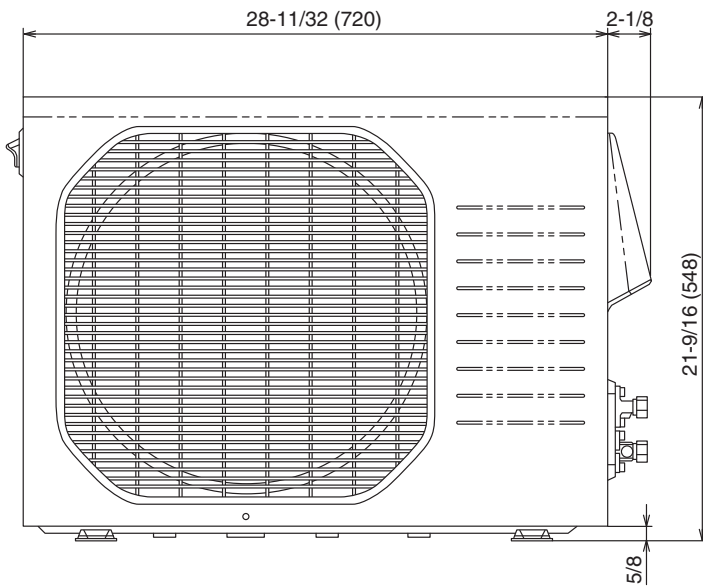
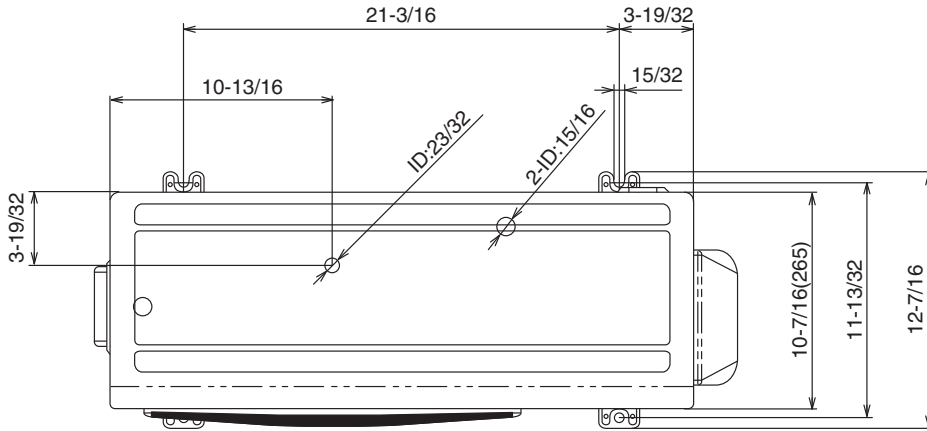

Unit : inch (mm)  
(852-0-0010-12600-0)



Outdoor Unit **CU-KS18NKU**  
**CU-KS18NKUA**

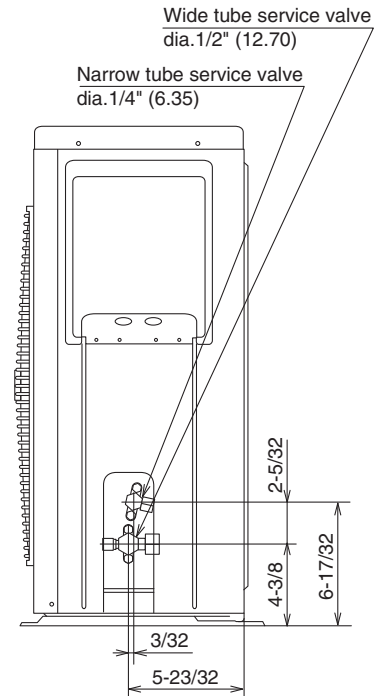
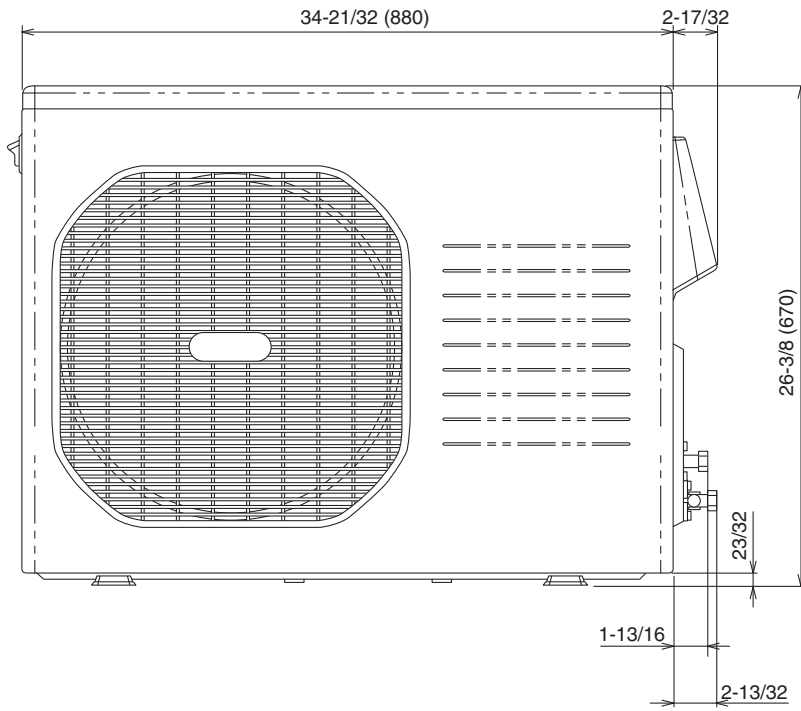
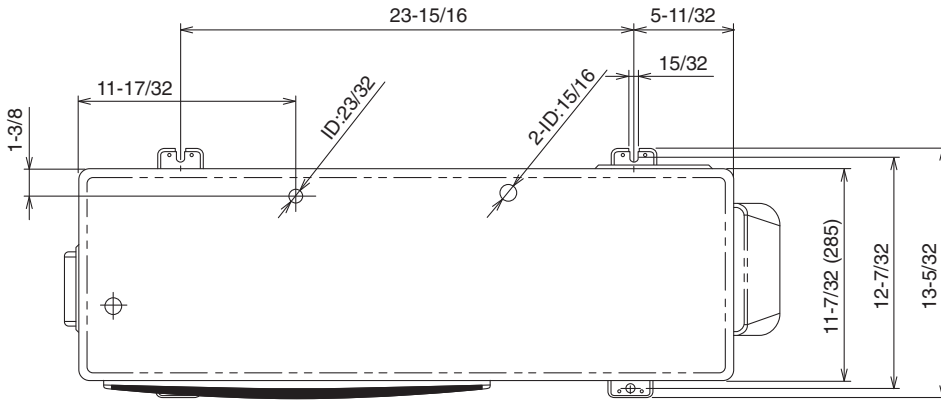

Unit : inch (mm)  
 (852-0-0010-13300-0)

# 4. REFRIGERANT FLOW DIAGRAM

## 4-1. Refrigerant Flow Diagram

Indoor Unit CS-KS12NB41 & CZ-18BT1U

Outdoor Unit CU-KS12NK1A

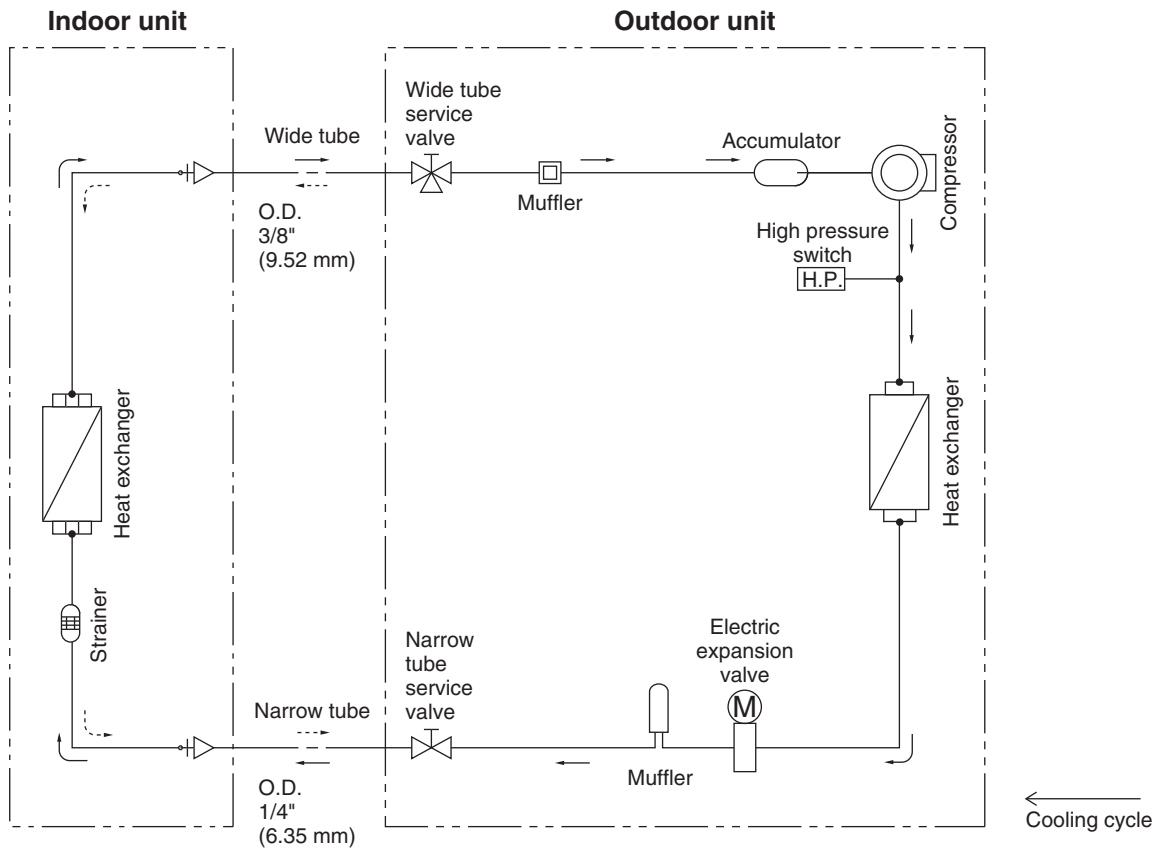

Indoor Unit **CS-KS18NB4UW & CZ-18BT1U** Outdoor Unit **CU-KS18NKU  
CU-KS18NKUA**

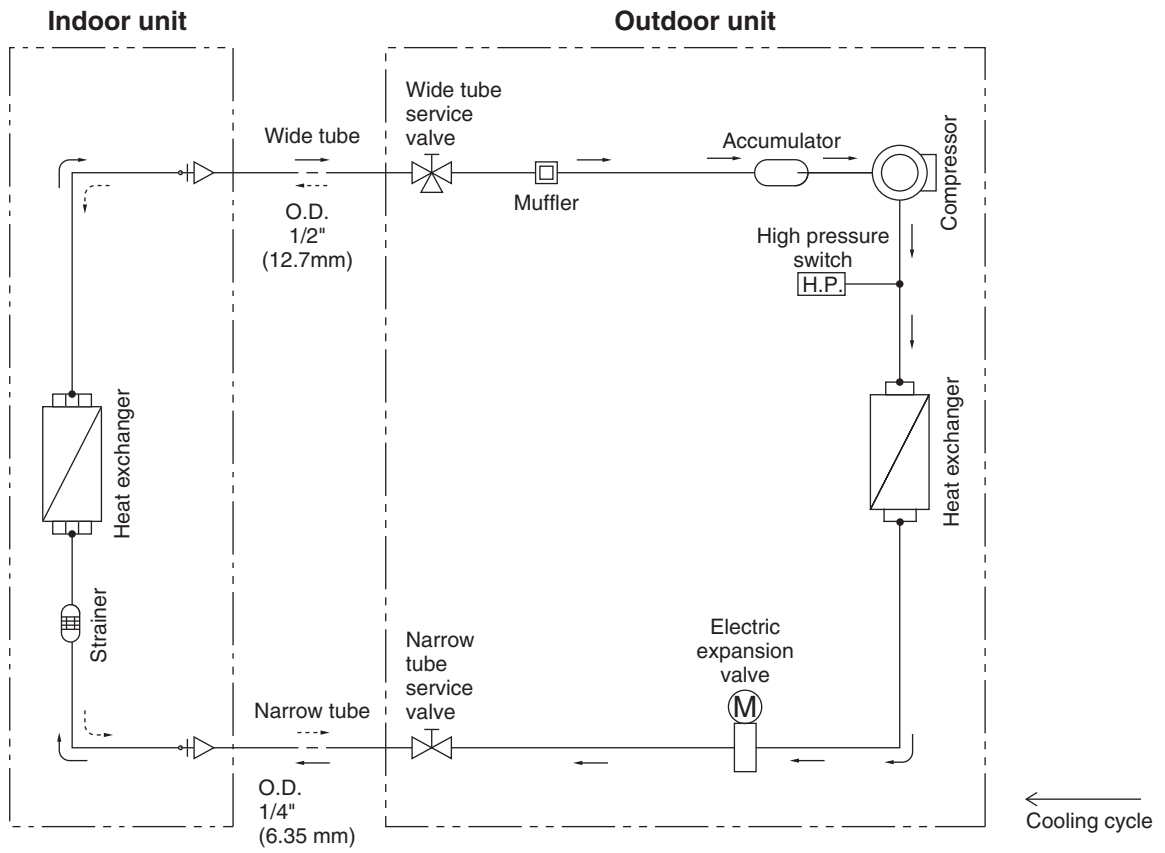

# 5. PERFORMANCE DATA

## 5-1. Temperature Charts

Indoor Unit **CS-KS12NB41 & CZ-18BT1U**

Outdoor Unit **CU-KS12NK1A**

■ Cooling Characteristics (RH : 46%, Indoor fan speed : High fan) (60Hz, 115V)

(1) Low pressure performance chart

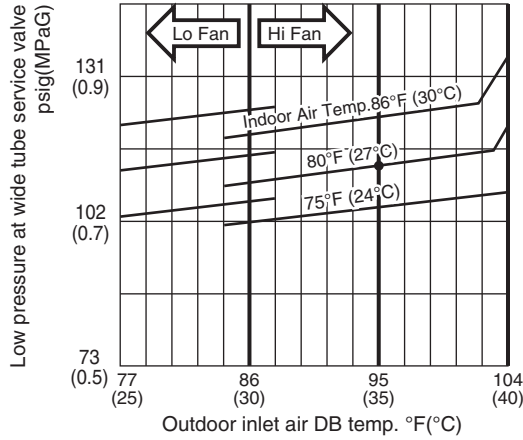

(2) Operating current performance chart

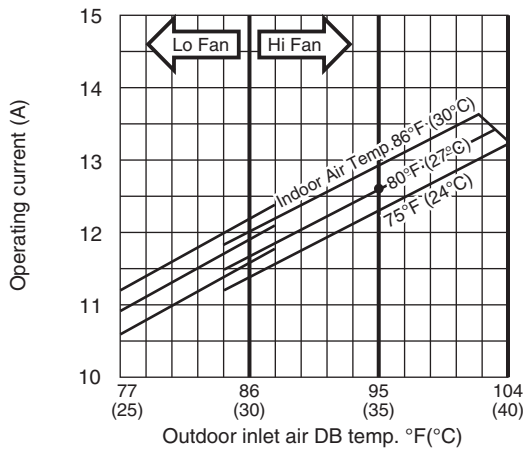

(3) Indoor discharge air performance chart

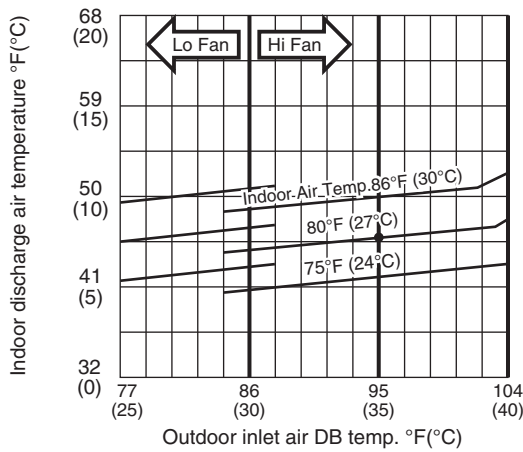

**NOTE**

• Check each performance value in test-run mode. Electrical performance values represent a combined indoor/outdoor value.

Indoor Unit **CS-KS18NB4UW & CZ-18BT1U**

Outdoor Unit **CU-KS18NKU or CU-KS18NKUA**

■ Cooling Characteristics (RH : 46%, Indoor fan speed : High fan) (60Hz, 230V)

(1) Low pressure performance chart

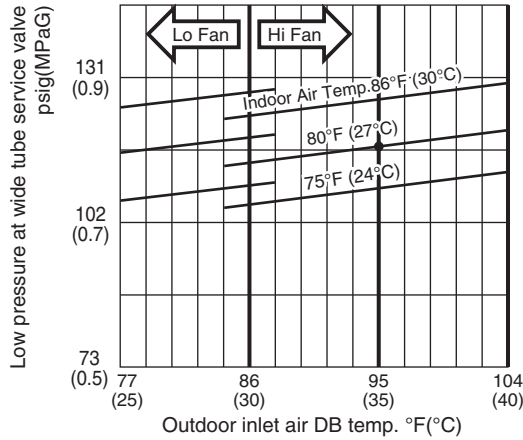

(2) Operating current performance chart

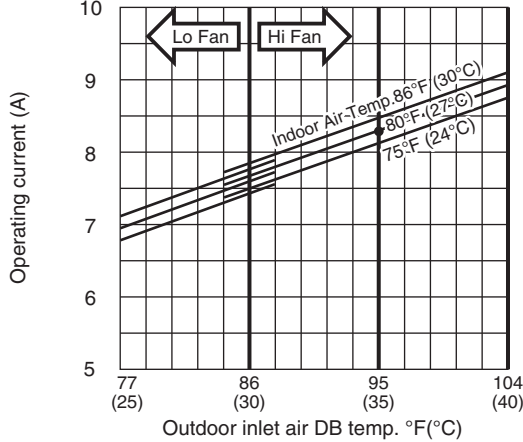

(3) Indoor discharge air performance chart

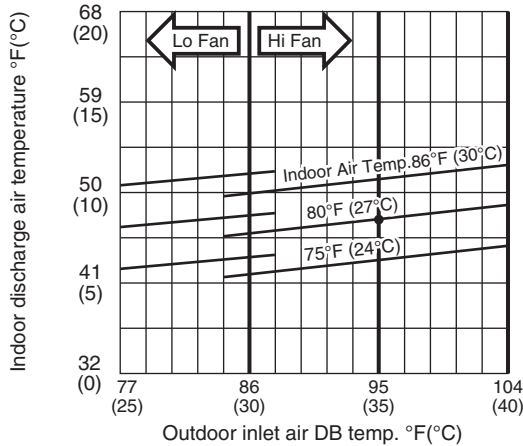

**NOTE**

- Check each performance value in test-run mode. Electrical performance values represent a combined indoor/outdoor value.

## 5-2. Cooling Capacity

Indoor Unit : **CS-KS12NB41 & CZ-18BT1U**

Outdoor Unit : **CU-KS12NK1A**

Power Supply : 115V Single Phase 60Hz

< Cooling Capacity >

RATING CAPACITY:		11,900 BTU/h		AIR FLOW RATE:		235 CFM		
INDOOR		OUTDOOR						
ENT. TEMP. °F (°C)		AMBIENT TEMP. °F (°C)						
WB	DB		65 (18.3)	75 (23.9)	85 (29.4)	95 (35.0)	105 (40.6)	115 (46.1)
59 (15.0)		TC	8,350	8,570	8,800	8,930	9,210	7,830
	72 (22.2)	SHC	6,340	6,430	6,570	6,610	6,800	6,060
	76 (24.4)	SHC	7,210	7,300	7,440	7,480	7,660	6,930
	80 (26.7)	SHC	8,120	8,210	8,350	8,400	8,530	7,830
	84 (28.9)	SHC	8,350	8,570	8,800	8,930	9,210	7,830
	88 (31.1)	SHC	8,350	8,570	8,800	8,930	9,210	7,830
63 (17.2)		TC	12,230	12,030	11,790	11,580	10,580	7,950
	72 (22.2)	SHC	7,070	6,930	6,840	6,700	6,200	4,970
	76 (24.4)	SHC	7,940	7,800	7,710	7,570	7,070	5,840
	80 (26.7)	SHC	8,850	8,720	8,580	8,490	7,980	6,750
	84 (28.9)	SHC	9,720	9,590	9,450	9,360	8,850	7,620
	88 (31.1)	SHC	10,590	10,450	10,360	10,230	9,720	7,950
67 (19.4)		TC	12,460	12,290	12,070	# 11,900	10,700	8,040
	72 (22.2)	SHC	5,790	5,700	5,610	5,520	4,970	3,870
	76 (24.4)	SHC	6,660	6,570	6,480	6,380	5,880	4,740
	80 (26.7)	SHC	7,570	7,480	7,390	7,300	6,750	5,650
	84 (28.9)	SHC	8,440	8,350	8,260	8,170	7,620	6,520
	88 (31.1)	SHC	9,310	9,220	9,130	9,040	8,490	7,390
71 (21.7)		TC	12,640	12,490	12,300	12,170	10,770	8,100
	72 (22.2)	SHC	4,460	4,420	4,330	4,280	3,690	2,680
	76 (24.4)	SHC	5,330	5,290	5,200	5,150	4,560	3,550
	80 (26.7)	SHC	6,250	6,200	6,110	6,060	5,470	4,460
	84 (28.9)	SHC	7,120	7,070	6,980	6,930	6,340	5,330
	88 (31.1)	SHC	7,980	7,940	7,850	7,800	7,210	6,200
75 (23.9)		TC	12,730	12,610	12,450	12,370	10,780	8,120
	76 (24.4)	SHC	4,050	4,010	3,960	3,920	3,370	2,450
	80 (26.7)	SHC	4,970	4,920	4,880	4,830	4,280	3,370
	84 (28.9)	SHC	5,840	5,790	5,740	5,700	5,150	4,240
	88 (31.1)	SHC	6,700	6,660	6,610	6,570	6,020	5,100

TC : Total Cooling Capacity (BTU/h) SHC : Sensible Heat Capacity (BTU/h)

### NOTE

- Rating conditions (#) : Indoor Unit Entering Air Temp. 80 °F (26.7 °C) DB / 67 °F (19.4 °C) WB  
: Outdoor Ambient Temp. 95 °F (35 °C) DB
- Above data does not take Freeze Prevention Protection during cooling operation into account.  
For this reason, the value may vary from the actual cooling characteristics.
- Above data represents the value when the operation frequency of a compressor is fixed.

Indoor Unit : **CS-KS18NB4UW & CZ-18BT1U**  
 Outdoor Unit : **CU-KS18NKU or CU-KS18NKUA**  
 Power Supply : 230V Single Phase 60Hz

< Cooling Capacity >

RATING CAPACITY:		17,500 BTU/h		AIR FLOW RATE:		341 CFM		
INDOOR		OUTDOOR						
ENT. TEMP. °F (°C)		AMBIENT TEMP. °F (°C)						
WB	DB		65 (18.3)	75 (23.9)	85 (29.4)	95 (35.0)	105 (40.6)	115 (46.1)
59 (15.0)		TC	12,260	12,550	12,830	13,060	13,460	9,520
	72 (22.2)	SHC	9,140	9,270	9,400	9,540	9,740	7,810
	76 (24.4)	SHC	10,330	10,470	10,600	10,730	10,930	9,010
	80 (26.7)	SHC	11,590	11,720	11,860	11,990	12,190	9,520
	84 (28.9)	SHC	12,260	12,550	12,830	13,060	13,380	9,520
	88 (31.1)	SHC	12,260	12,550	12,830	13,060	13,460	9,520
63 (17.2)		TC	18,110	17,790	17,400	17,000	14,080	9,650
	72 (22.2)	SHC	10,400	10,200	10,000	9,800	8,340	6,290
	76 (24.4)	SHC	11,590	11,390	11,190	11,000	9,540	7,480
	80 (26.7)	SHC	12,850	12,650	12,450	12,260	10,800	8,740
	84 (28.9)	SHC	14,040	13,850	13,650	13,450	11,990	9,650
	88 (31.1)	SHC	15,240	15,110	14,840	14,640	13,180	9,650
67 (19.4)		TC	18,510	18,220	17,860	# 17,500	14,220	9,750
	72 (22.2)	SHC	8,680	8,480	8,340	8,140	6,620	4,830
	76 (24.4)	SHC	9,870	9,740	9,540	9,340	7,880	6,020
	80 (26.7)	SHC	11,130	10,930	10,800	10,600	9,070	7,280
	84 (28.9)	SHC	12,320	12,190	11,990	11,790	10,330	8,480
	88 (31.1)	SHC	13,510	13,380	13,180	12,980	11,530	9,670
71 (21.7)		TC	18,820	18,570	18,260	17,940	14,290	9,810
	72 (22.2)	SHC	6,750	6,690	6,550	6,420	4,900	3,240
	76 (24.4)	SHC	7,950	7,880	7,750	7,610	6,090	4,430
	80 (26.7)	SHC	9,210	9,140	9,010	8,870	7,350	5,690
	84 (28.9)	SHC	10,470	10,330	10,200	10,070	8,540	6,890
	88 (31.1)	SHC	11,660	11,530	11,390	11,260	9,740	8,080
75 (23.9)		TC	19,010	18,800	18,530	18,260	14,280	9,810
	76 (24.4)	SHC	6,160	6,090	5,960	5,890	4,430	2,970
	80 (26.7)	SHC	7,420	7,350	7,220	7,150	5,690	4,230
	84 (28.9)	SHC	8,610	8,540	8,410	8,340	6,890	5,430
	88 (31.1)	SHC	9,800	9,740	9,670	9,540	8,080	6,620

TC : Total Cooling Capacity (BTU/h) SHC : Sensible Heat Capacity (BTU/h)

**NOTE**

- Rating conditions (#) : Indoor Unit Entering Air Temp. 80 °F (26.7 °C) DB / 67 °F (19.4 °C) WB  
 : Outdoor Ambient Temp. 95 °F (35 °C) DB
- Above data does not take Freeze Prevention Protection during cooling operation into account.  
 For this reason, the value may vary from the actual cooling characteristics.
- Above data represents the value when the operation frequency of a compressor is fixed.

### 5-3. Cooling Capacity (Low Ambient)

Indoor Unit : **CS-KS12NB41 & CZ-18BT1U**

Outdoor Unit : **CU-KS12NK1A**

Power Supply : 115V Single Phase 60Hz

< Cooling Capacity (Low Ambient) >

RATING CAPACITY:		11,900 BTU/h		AIR FLOW RATE:		235 CFM			
INDOOR		OUTDOOR							
ENT. TEMP. °F (°C)		AMBIENT TEMP. °F (°C)							
WB	DB		0 (-17.8)	5 (-15.0)	15 (-9.4)	25 (-3.9)	35 (1.7)	45 (7.2)	55 (12.8)
59 (15.0)		TC	9,530	9,550	9,560	9,590	9,600	9,590	9,570
	72 (22.2)	SHC	6,930	6,930	6,980	8,580	6,980	6,980	6,980
	76 (24.4)	SHC	7,800	7,800	7,850	9,450	7,850	7,850	7,850
	80 (26.7)	SHC	8,720	8,720	8,720	9,590	8,760	8,760	8,760
	84 (28.9)	SHC	9,530	9,550	9,560	9,590	9,600	9,590	9,570
	88 (31.1)	SHC	9,530	9,550	9,560	9,590	9,600	9,590	9,570
63 (17.2)		TC	9,440	9,460	9,530	9,590	9,650	9,660	9,670
	72 (22.2)	SHC	5,650	5,650	5,700	8,580	5,740	5,740	5,790
	76 (24.4)	SHC	6,520	6,520	6,570	9,450	6,610	6,610	6,660
	80 (26.7)	SHC	7,440	7,440	7,480	9,590	7,530	7,530	7,530
	84 (28.9)	SHC	8,300	8,300	8,350	9,590	8,400	8,400	8,400
	88 (31.1)	SHC	9,170	9,170	9,220	9,590	9,270	9,270	9,270
67 (19.4)		TC	9,250	9,290	9,410	9,530	9,620	9,670	9,720
	72 (22.2)	SHC	4,370	4,370	4,420	8,580	4,510	4,560	4,560
	76 (24.4)	SHC	5,240	5,240	5,290	9,450	5,380	5,420	5,420
	80 (26.7)	SHC	6,160	6,160	6,200	9,530	6,290	6,340	6,340
	84 (28.9)	SHC	7,020	7,020	7,070	9,530	7,160	7,210	7,210
	88 (31.1)	SHC	7,890	7,890	7,940	9,530	8,030	8,080	8,080
71 (21.7)		TC	8,950	9,010	9,210	9,380	9,520	9,610	9,710
	72 (22.2)	SHC	3,000	3,050	3,090	8,580	3,230	3,280	3,280
	76 (24.4)	SHC	3,870	3,920	3,960	9,380	4,100	4,140	4,140
	80 (26.7)	SHC	4,780	4,830	4,880	9,380	5,010	5,060	5,060
	84 (28.9)	SHC	5,650	5,700	5,740	9,380	5,880	5,930	5,930
	88 (31.1)	SHC	6,520	6,570	6,610	9,380	6,750	6,800	6,800
75 (23.9)		TC	8,590	8,650	8,930	9,160	9,360	9,480	9,620
	76 (24.4)	SHC	2,590	2,640	2,730	9,160	2,860	2,910	2,960
	80 (26.7)	SHC	3,500	3,550	3,640	9,160	3,780	3,820	3,870
	84 (28.9)	SHC	4,370	4,420	4,510	9,160	4,650	4,690	4,740
	88 (31.1)	SHC	5,240	5,290	5,380	9,160	5,520	5,560	5,610

TC : Total Cooling Capacity (BTU/h) SHC : Sensible Heat Capacity (BTU/h)

**NOTE**

1. Above data does not take Freeze Prevention Protection during cooling operation into account. For this reason, the value may vary from the actual cooling characteristics.
2. Above data represents the value when the operation frequency of a compressor is fixed.



Indoor Unit : **CS-KS18NB4UW & CZ-18BT1U**

Outdoor Unit : **CU-KS18NKUA**

Power Supply : 230V Single Phase 60Hz

< Cooling Capacity (Low Ambient) >

RATING CAPACITY: 17,500 BTU/h			AIR FLOW RATE: 341 CFM						
INDOOR		OUTDOOR							
ENT. TEMP. °F (°C)		AMBIENT TEMP. °F (°C)							
WB	DB		0 (-17.8)	5 (-15.0)	15 (-9.4)	25 (-3.9)	35 (1.7)	45 (7.2)	55 (12.8)
59 (15.0)		TC	13,400	13,430	13,440	13,470	13,500	13,520	13,510
	72 (22.2)	SHC	9,740	9,740	9,740	11,860	9,740	9,800	9,800
	76 (24.4)	SHC	10,930	10,930	10,930	13,050	11,000	11,000	11,000
	80 (26.7)	SHC	12,190	12,190	12,190	13,470	12,190	12,260	12,190
	84 (28.9)	SHC	13,380	13,380	13,380	13,470	13,380	13,450	13,450
	88 (31.1)	SHC	13,400	13,430	13,440	13,470	13,500	13,520	13,510
63 (17.2)		TC	13,260	13,300	13,370	13,480	13,560	13,640	13,670
	72 (22.2)	SHC	7,950	7,950	7,950	11,860	8,080	8,080	8,140
	76 (24.4)	SHC	9,140	9,140	9,210	13,050	9,270	9,270	9,340
	80 (26.7)	SHC	10,400	10,400	10,400	13,480	10,530	10,530	10,600
	84 (28.9)	SHC	11,590	11,590	11,590	13,480	11,720	11,720	11,790
	88 (31.1)	SHC	12,790	12,790	12,850	13,480	12,920	12,980	12,980
67 (19.4)		TC	12,980	13,040	13,170	13,380	13,530	13,670	13,760
	72 (22.2)	SHC	6,090	6,160	6,220	11,860	6,360	6,420	6,420
	76 (24.4)	SHC	7,280	7,350	7,420	13,050	7,550	7,610	7,680
	80 (26.7)	SHC	8,540	8,610	8,680	13,380	8,810	8,870	8,870
	84 (28.9)	SHC	9,740	9,800	9,870	13,380	10,000	10,070	10,070
	88 (31.1)	SHC	11,000	11,000	11,060	13,380	11,190	11,260	11,330
71 (21.7)		TC	12,550	12,630	12,830	13,160	13,390	13,600	13,750
	72 (22.2)	SHC	4,230	4,230	4,370	11,860	4,570	4,630	4,700
	76 (24.4)	SHC	5,430	5,490	5,560	13,050	5,760	5,820	5,890
	80 (26.7)	SHC	6,690	6,690	6,820	13,160	7,020	7,080	7,150
	84 (28.9)	SHC	7,880	7,950	8,010	13,160	8,210	8,280	8,340
	88 (31.1)	SHC	9,070	9,140	9,210	13,160	9,400	9,470	9,540
75 (23.9)		TC	12,010	12,110	12,380	12,850	13,150	13,440	13,650
	76 (24.4)	SHC	3,640	3,700	3,770	12,850	4,030	4,170	4,230
	80 (26.7)	SHC	4,900	4,960	5,030	12,850	5,290	5,360	5,490
	84 (28.9)	SHC	6,090	6,160	6,220	12,850	6,490	6,620	6,690
	88 (31.1)	SHC	7,280	7,350	7,420	12,850	7,680	7,810	7,880

TC : Total Cooling Capacity (BTU/h) SHC : Sensible Heat Capacity (BTU/h)

**NOTE**

1. Above data does not take Freeze Prevention Protection during cooling operation into account. For this reason, the value may vary from the actual cooling characteristics.
2. Above data represents the value when the operation frequency of a compressor is fixed.

## 6. ELECTRICAL DATA

### 6-1. Electrical Characteristics

Indoor Unit **CS-KS12NB41 & CZ-18BT1U**

Outdoor Unit **CU-KS12NK1A**

#### Cooling

			Indoor Unit	Outdoor Unit	Complete Unit
			Fan Motor	Fan Motor + Compressor	
Performance at			115V Single-phase 60Hz		
Rating conditions	Running amp.	A	0.21	12.39	12.6
	Power input	W	18	1,242	1,260

Rating conditions: Indoor air temperature: 80 °F (26.7 °C) DB / 67 °F (19.4 °C) WB  
 Outdoor air temperature: 95 °F (35 °C) DB

Indoor Unit **CS-KS18NB4UW & CZ-18BT1U**  
 Outdoor Unit **CU-KS18NKU**

**Cooling**

< 230V >

			Indoor Unit	Outdoor Unit	Complete Unit
			Fan Motor	Fan Motor + Compressor	
Performance at			230V Single-phase 60Hz		
Rating conditions	Running amp.	A	0.15	8.15	8.3
	Power input	W	22	1,838	1,860

Rating conditions: Indoor air temperature: 80 °F (26.7 °C) DB / 67 °F (19.4 °C) WB  
 Outdoor air temperature: 95 °F (35 °C) DB

**Cooling**

< 208V >

			Indoor Unit	Outdoor Unit	Complete Unit
			Fan Motor	Fan Motor + Compressor	
Performance at			208V Single-phase 60Hz		
Rating conditions	Running amp.	A	0.16	8.94	9.1
	Power input	W	22	1,838	1,860

Rating conditions: Indoor air temperature: 80 °F (26.7 °C) DB / 67 °F (19.4 °C) WB  
 Outdoor air temperature: 95 °F (35 °C) DB

Indoor Unit **CS-KS18NB4UW & CZ-18BT1U**  
 Outdoor Unit **CU-KS18NKUA**

**Cooling**

< 230V >

			Indoor Unit	Outdoor Unit	Complete Unit
			Fan Motor	Fan Motor + Compressor	
Performance at			230V Single-phase 60Hz		
Rating conditions	Running amp.	A	0.15	8.15	8.3
	Power input	W	22	1,838	1,860

Rating conditions: Indoor air temperature: 80 °F (26.7 °C) DB / 67 °F (19.4 °C) WB  
 Outdoor air temperature: 95 °F (35 °C) DB

**Cooling**

< 208V >

			Indoor Unit	Outdoor Unit	Complete Unit
			Fan Motor	Fan Motor + Compressor	
Performance at			208V Single-phase 60Hz		
Rating conditions	Running amp.	A	0.16	8.94	9.1
	Power input	W	22	1,838	1,860

Rating conditions: Indoor air temperature: 80 °F (26.7 °C) DB / 67 °F (19.4 °C) WB  
 Outdoor air temperature: 95 °F (35 °C) DB

# 6-2. Electric Wiring Diagrams

Indoor Unit **CS-KS12NB41 & CZ-18BT1U**  
**CS-KS18NB4UW & CZ-18BT1U**

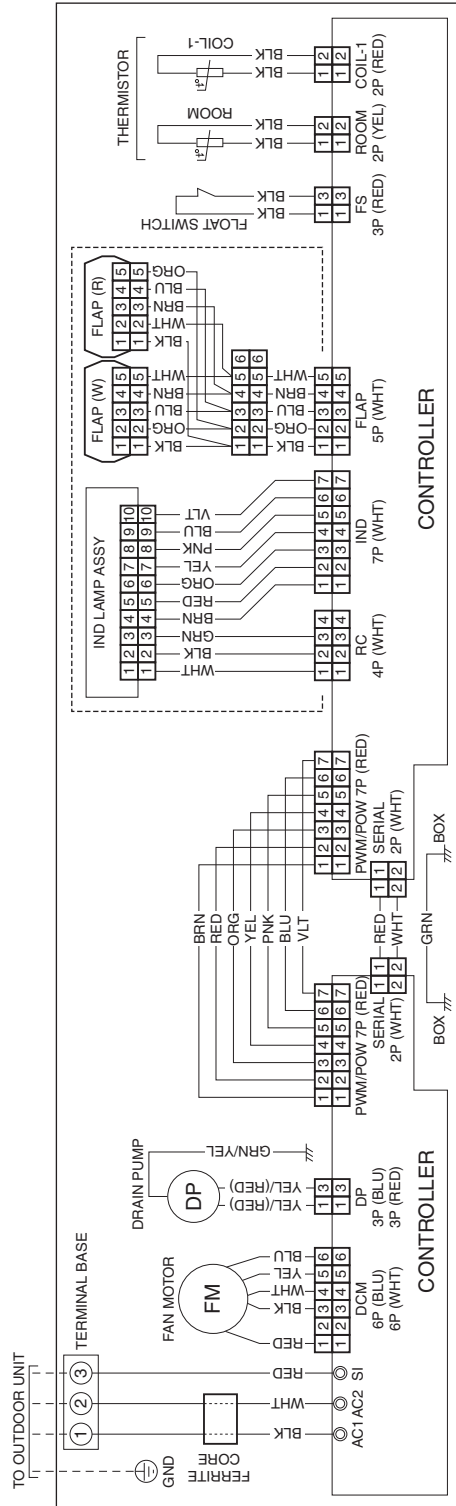

8FA2-5250-46900-2

Outdoor Unit **CU-KS12NK1A**

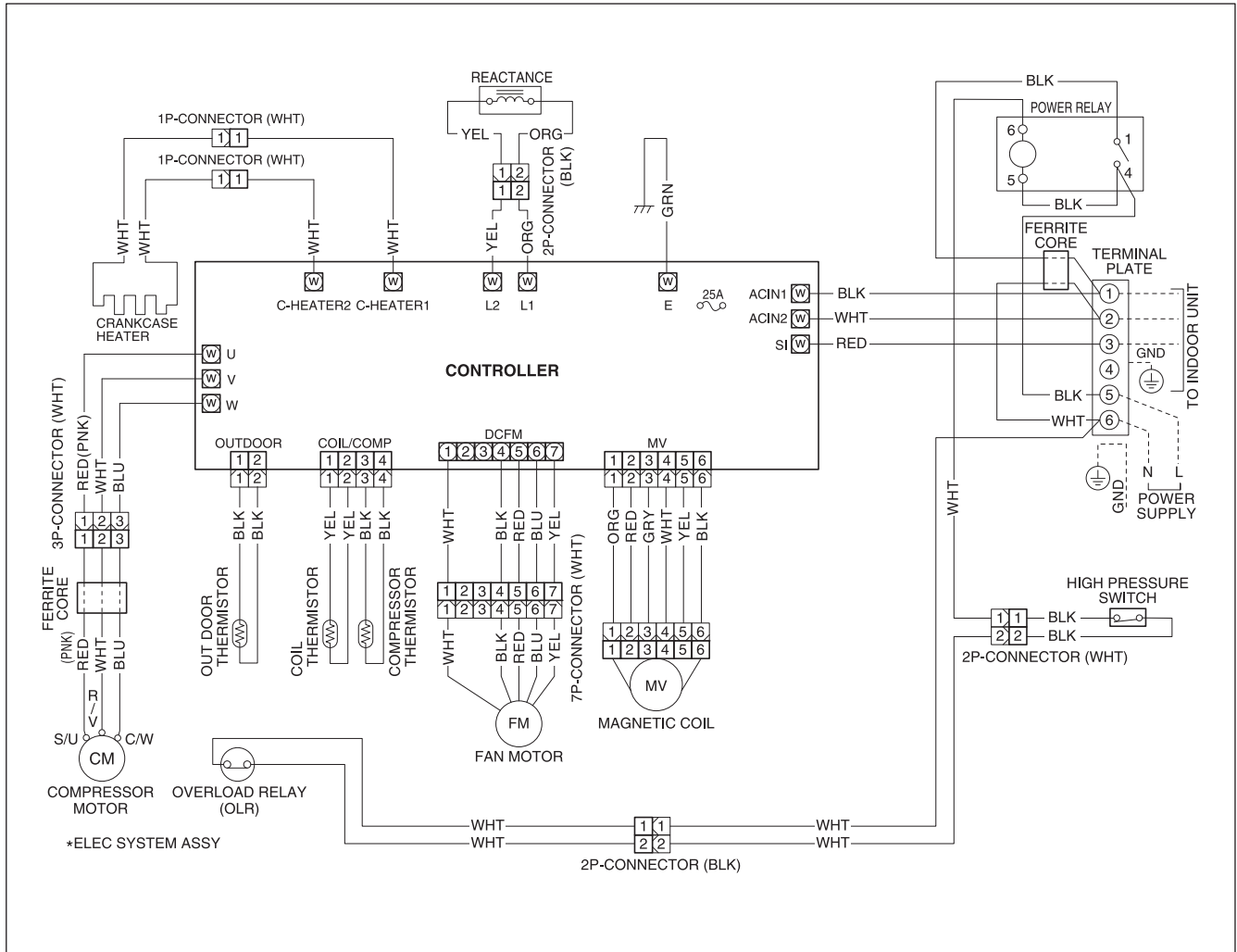

8FA2-5251-12300-2

Outdoor Unit **CU-KS18NKU CU-KS18NKUA**

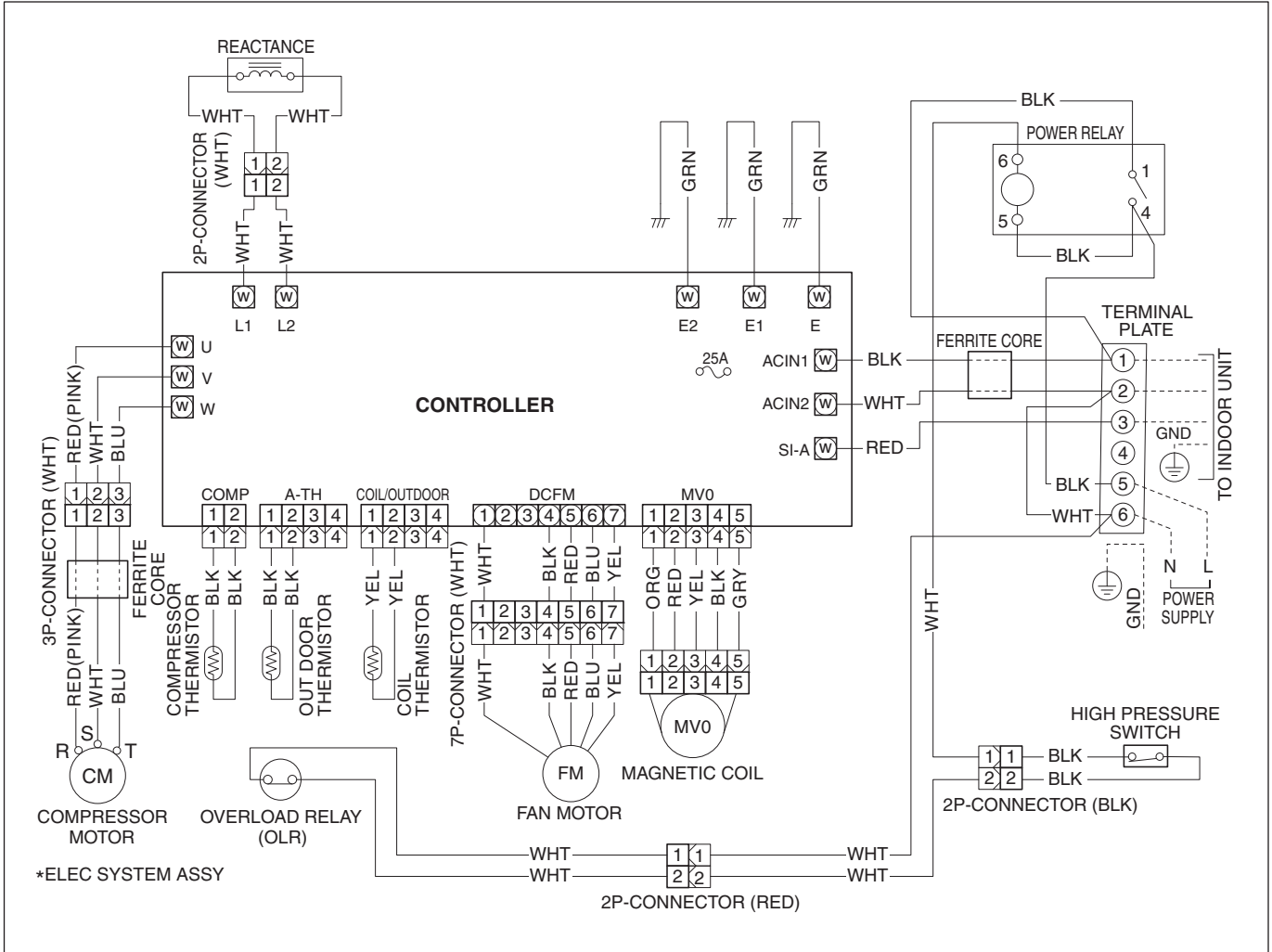

8FA2-5251-12000-2

# 7. MAINTENANCE

## 7-1. Address Setting of the Remote Controller

The address can be set in order to prevent interference between remote controllers when two indoor units are installed near each other. The address is normally set to "A." To set a different address, it is necessary to change the address on the second remote controller.

**NOTE**

Once changed, you cannot restore the original address setting of the air conditioner.

- (1) Switch on the power source.
- (2) Break the address-setting tab marked "A" on the second remote controller to change the address (Fig. 1). When the tab is removed, the address is automatically set to B (Fig. 2).
- (3) Press and hold the remote controller HIGH POWER button and 1 HR TIMER button. Then, press and hold the ACL (reset) button with a pointed object such as the tip of a pen. After 5 seconds, release ACL button first, then release HIGH POWER and 1 HR. TIMER buttons, "oP-1" (test run) appears, blinking in the remote controller clock display area.
- (4) Each time the 1 HR TIMER button is pressed, the display changes as shown below. Press this button 2 times to change the display to "oP-7" (address setting). (Fig. 3)

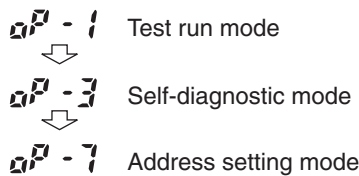

- (5) "oP-7" has now been selected for address setting.
- (6) Press the ON/OFF operation button on the remote controller. (Fig. 3) Check that the "beep" signal received sound is heard from the second indoor unit (approximately 5 times). The sound you hear is the signal that the remote controller address has been changed.
- (7) Finally press the remote controller ACL (reset) button to cancel the blinking "oP-7" display. (Fig. 3)

Changing of the second remote controller address is now completed.

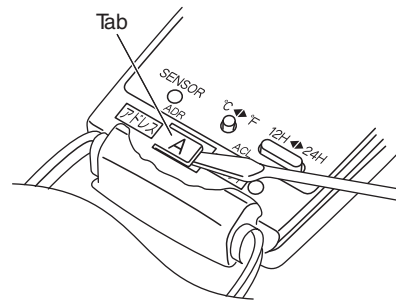

Fig. 1

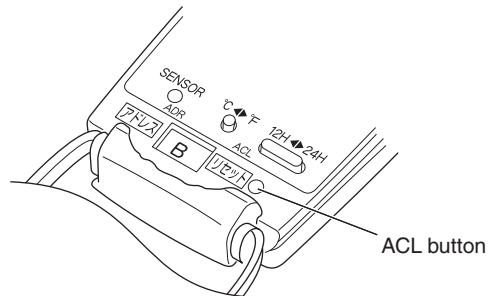

Fig. 2

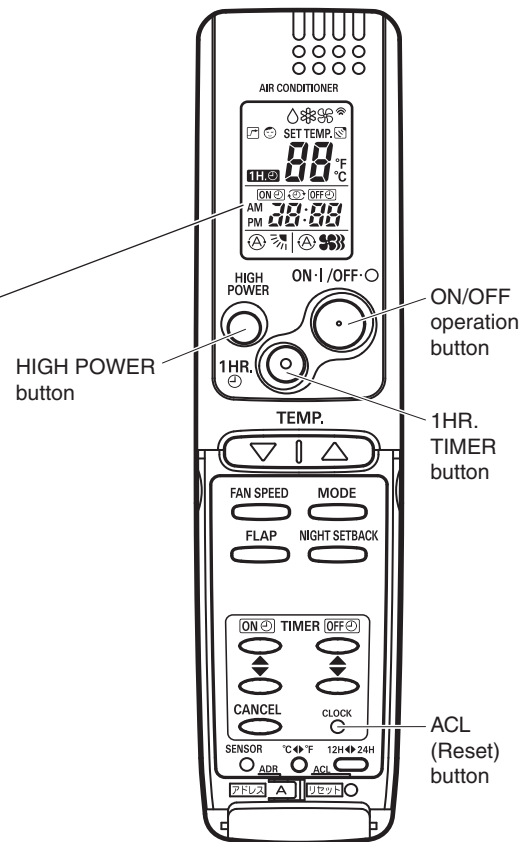
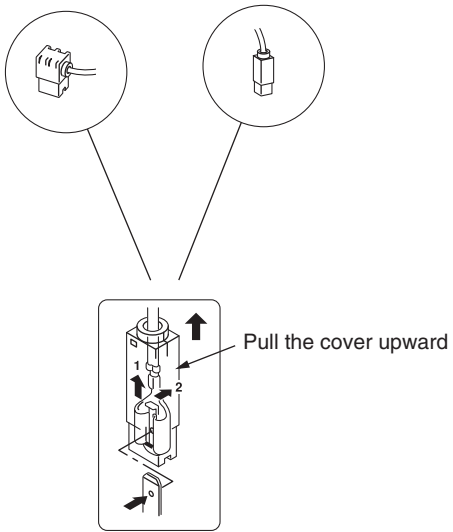

Fig. 3

## 7-2. Disconnecting and Connecting Positive Connector for Outdoor Unit



When the cover is pulled upward, the lock is released with the sequence of 1 and 2.

One of the two types of connectors illustrated at left is used. Their basic structure is the same for each.

### How to Disconnect

Hold the resin connector cover, and pull the connector off. You cannot disconnect the connector by pulling the wire since it is locked inside. Always hold the cover to disconnect. (See illustration at left.) For the connector without the resin cover, push the lock in the direction of "2" while pulling it off.

### How to Connect

In order to connect, hold the resin cover of the connector and push it in. Confirm the click sound for the inside lock.



## 7-3. Disassembly Procedure



### WARNING

- To avoid electrical shock hazard, be sure to disconnect power before attempting to disassemble the unit.
- When a footstool, etc. is used for disassembling the indoor unit, be careful not to fall down. If you fall down, you might be injured seriously.

### 7-3-1. Remove the air intake grill.

- (1) Slide the 2 latches each to the corresponding arrow direction. (Fig. 1 and Fig. 2)  
Open downward the air intake grill located on the latch side.
- (2) Undo the air intake grill drop preventive hook. (Fig. 3)  
Undo the 2 hinges for the grill and remove the air intake grill.

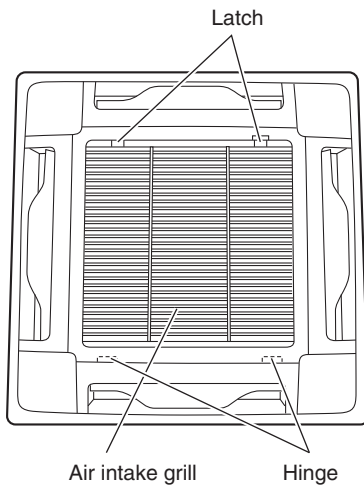

Fig.1

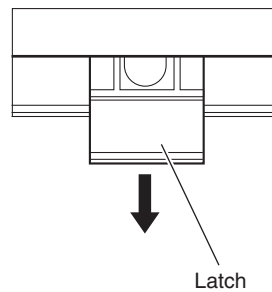

Fig.2

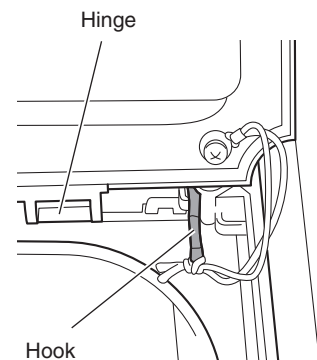

Fig.3

### 7-3-2. Disconnect the connectors in the control box.

- (1) Remove the 2 screws and remove the control box cover. (Fig. 4)
- (2) Disconnect the connectors CN04 (FLAP 5P), CN12 (RC 4P) and CN13 (IND 7P). (Fig. 5)

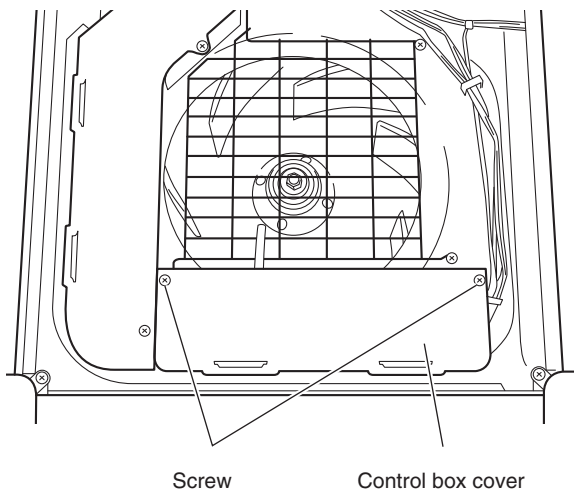

Fig.4

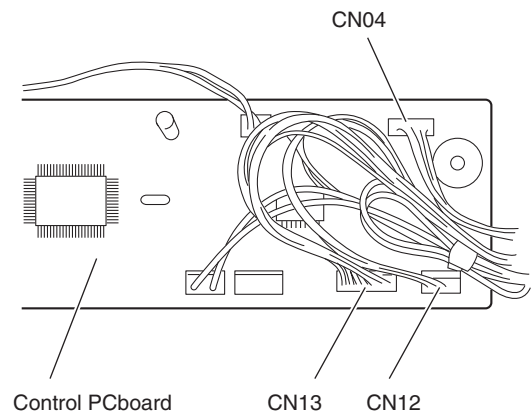

Fig.5

### 7-3-3. Remove the ceiling panel.

- (1) Open the clamp (4 locations) and remove the 2 lead wires from the clamps. (Fig. 6)
- (2) Remove the 4 screws fixing the corner cover (at 3 locations) and indicator cover (at 1 location). (Fig. 6)
- (3) Press the center 1 of the cover and remove the cover with the section 2 pulled down. (Fig. 7)
- (4) Remove the strap (3 locations) from the hook on the ceiling panel. (Fig. 8)

**NOTE** There is no strap on the indicator cover.

- (5) Remove the bolt (4 locations) with a washer and remove the ceiling panel. (Fig. 9)

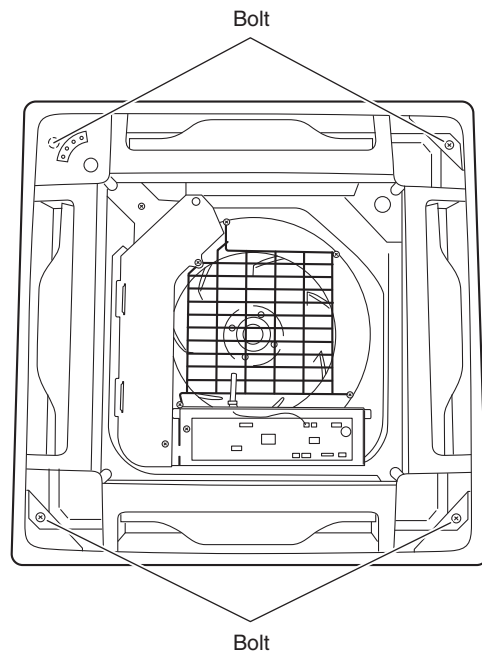
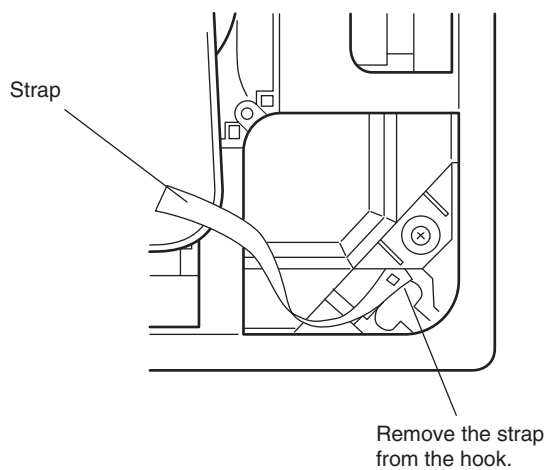
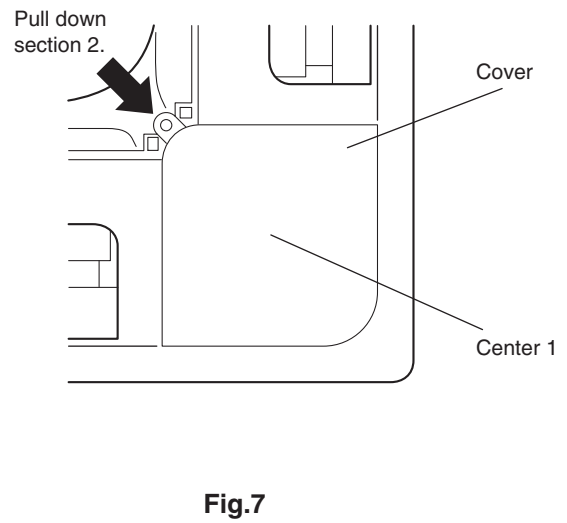
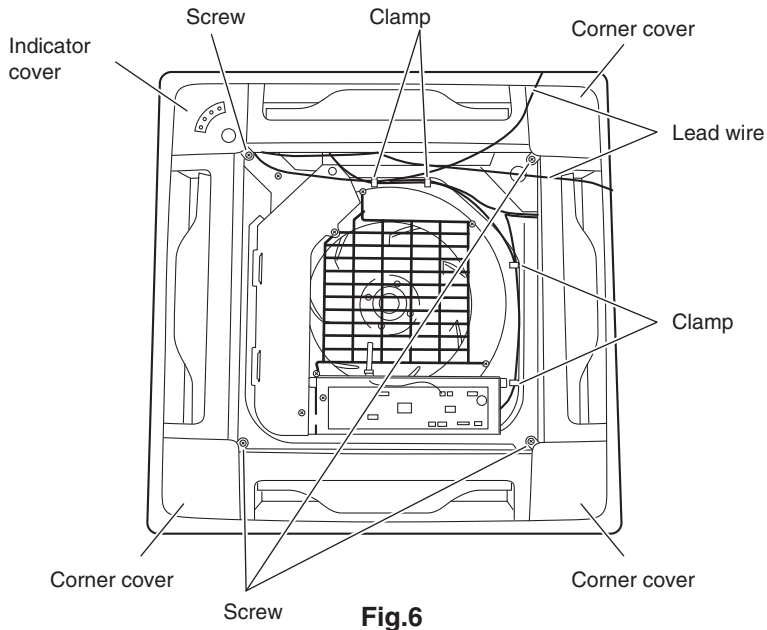

### 7-3-4. Remove the indoor air temperature sensor.

- (1) Disconnect the connector CN08 (ROOM 2P) in the control box and remove the indoor air temperature sensor. (Fig. 10)

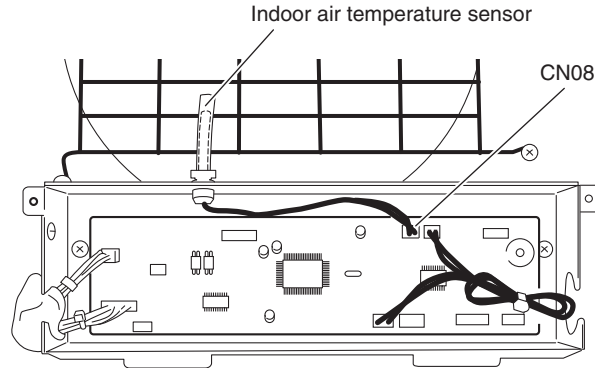

Fig.10

### 7-3-5. Remove the power box and control box.

- (1) Remove a screw and remove the terminal cover. (Fig. 11)
- (2) Remove the 2 screws and remove the power box cover. (Fig. 11)
- (3) Disconnect the power lines (No. 1 and No. 2) / signal line (No. 3) and ground cable from the terminals in the power box. (Fig. 12)

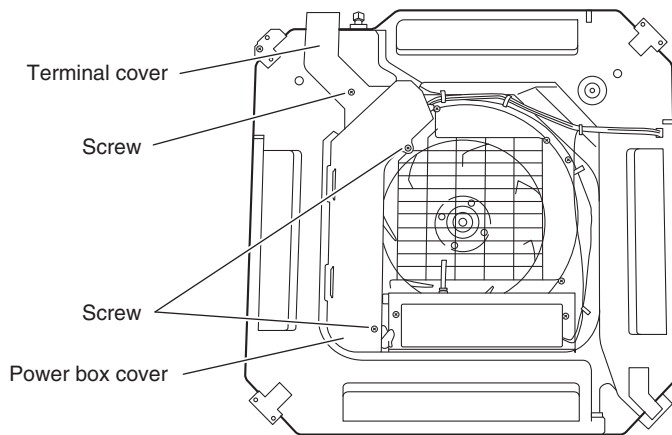

Fig.11

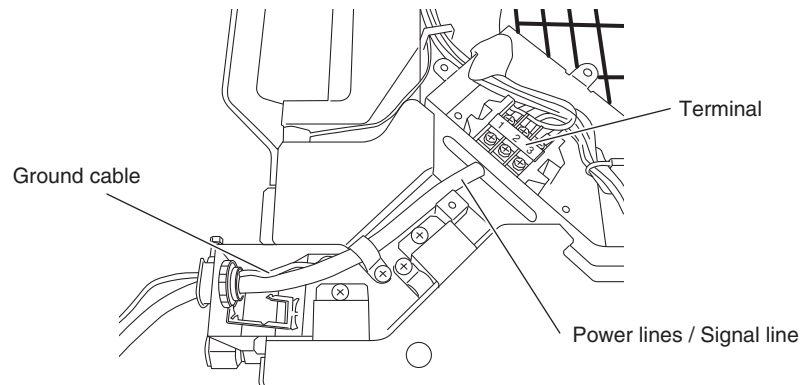
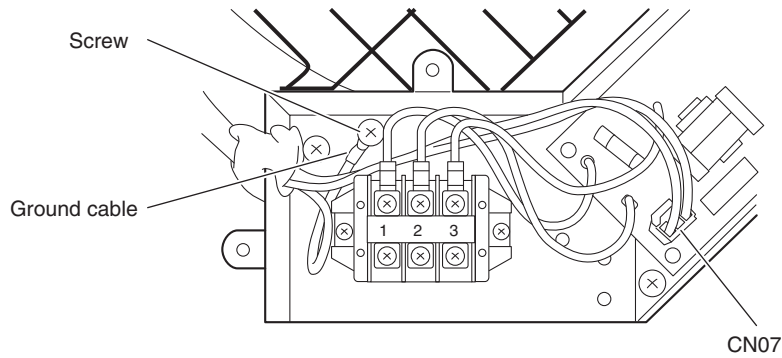
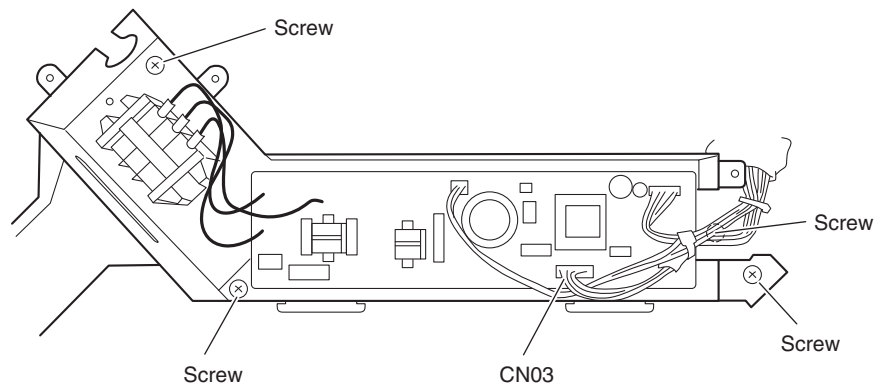

Fig.12

- (4) Disconnect the connector CN07 (DP 2P) in the power box. (Fig. 13)  
Remove a screw and disconnect the ground cable. (Fig. 13)
- (5) Disconnect the connector CN03 (DCM 6P) in the power box. (Fig. 14)
- (6) Remove the 4 screws and remove the power box. (Fig. 14)
- (7) Disconnect the connectors CN06 (FS 3P) and CN09 (COIL-1 2P) in the control box. (Fig. 15)
- (8) Remove the 2 screws and remove the control box. (Fig. 15)



**Fig.13**



**Fig.14**

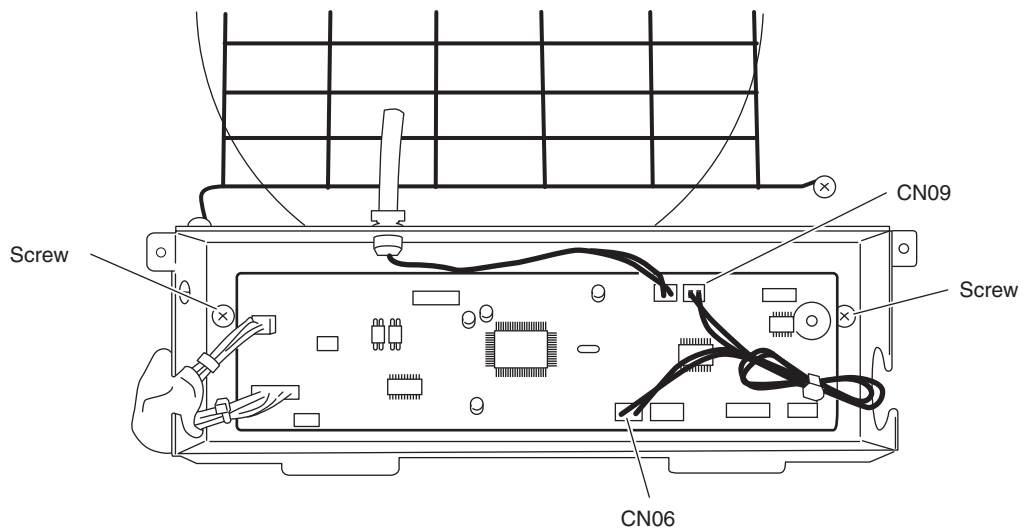

**Fig.15**

**NOTE** For the removal of the following components, perform any work after removing the indoor unit (main body) from the ceiling.

- Main body lower section
- Heat exchanger sensor
- Drain pump
- Float switch
- Turbo fan
- Fan motor
- Heat exchanger

1. Perform the work after draining the water to prevent the water leakage from the drain pan.
  - Put a bucket, etc., under the drain cap and remove the drain cap to drain the water.  
(Fig. 16)
2. Refer to the installation instructions for recovery of refrigerant or removal of the power cable or tubing.

### 7-3-6. Remove the main body lower section.

- (1) Remove the 4 screws. (Fig. 16)
- (2) Remove the 2 screws. (Fig. 17)
- (3) Disconnect the connector CN03 (DCM 6P) in the power box. (Fig. 18)
- (4) Lift the main body lower section and remove it from the main body upper section.

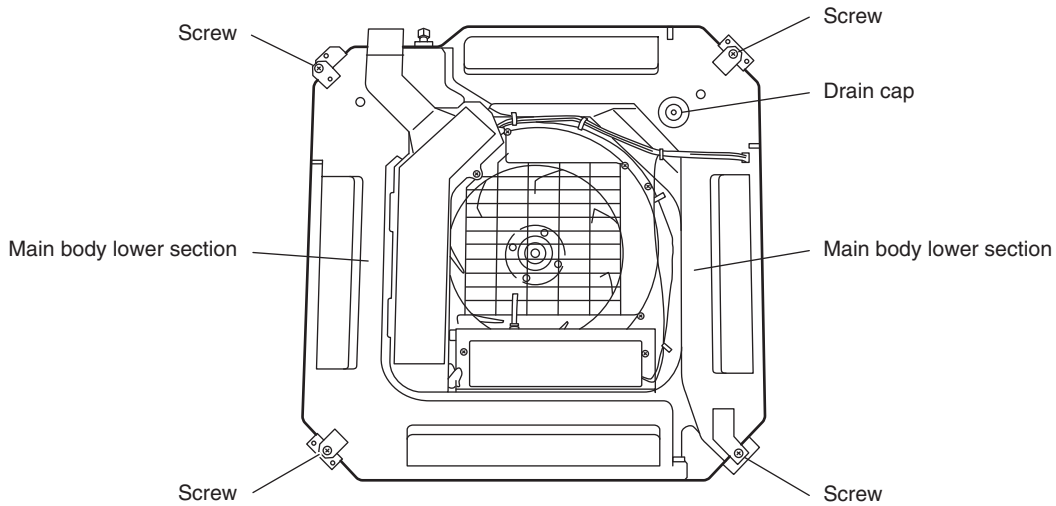

Fig.16

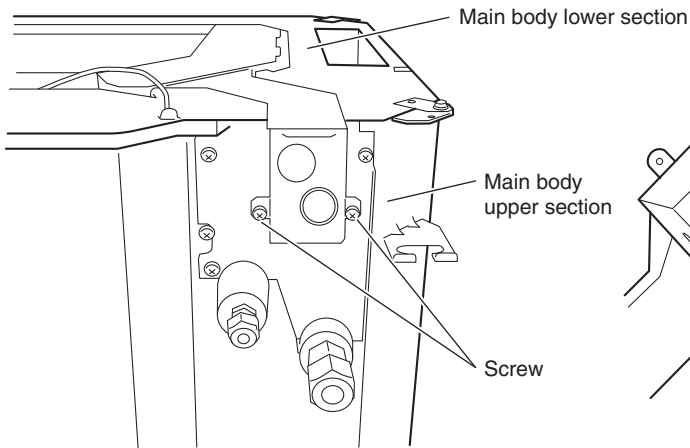

Fig.17

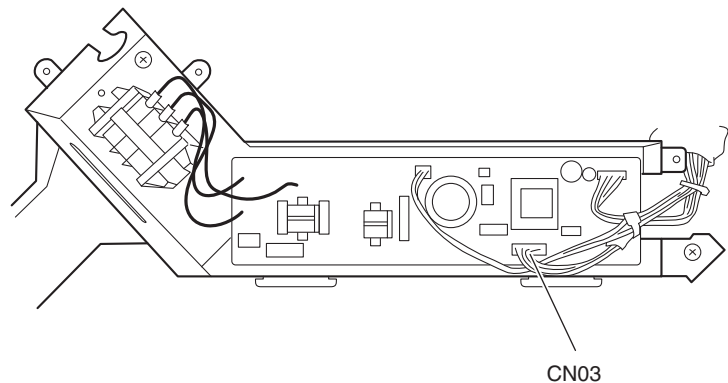

Fig.18

### 7-3-7. Remove the heat exchanger sensor.

- (1) Remove the heat exchanger sensor from the sensor holder. (Fig. 19)

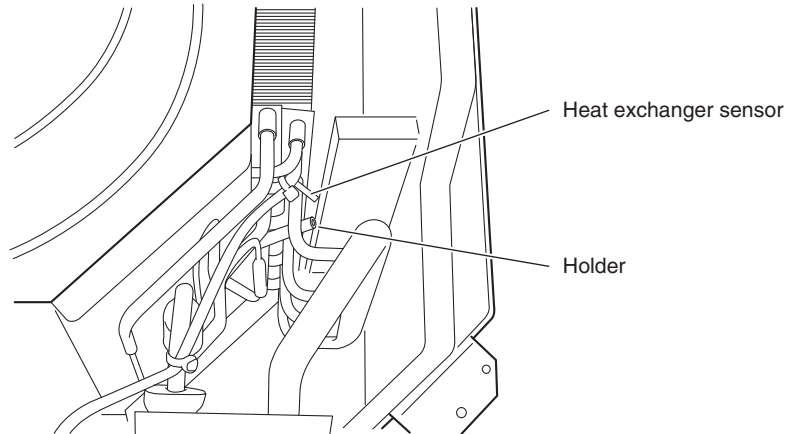

Fig.19

### 7-3-8. Remove the drain pump and float switch.

- (1) Remove the 2 screws (Fig. 20)
- (2) Loosen the clamp and disconnect the drain hose from the drain pump. (Fig. 20)
- (3) Remove the drain pump from the main body upper section. (Fig. 20)
- (4) Remove a nut and remove the float switch. (Fig. 21)

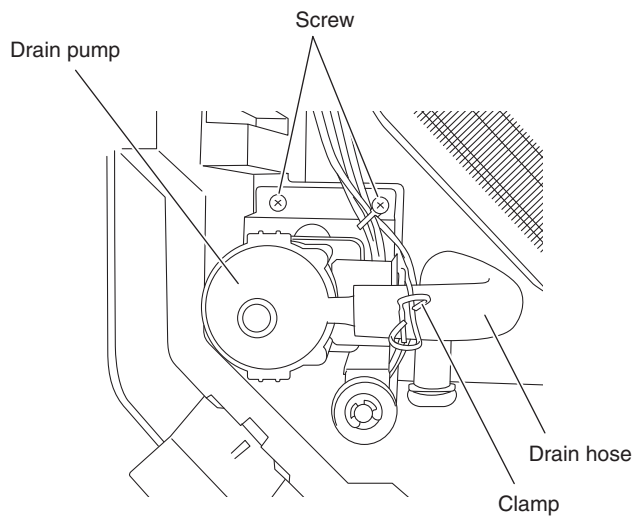

Fig.20

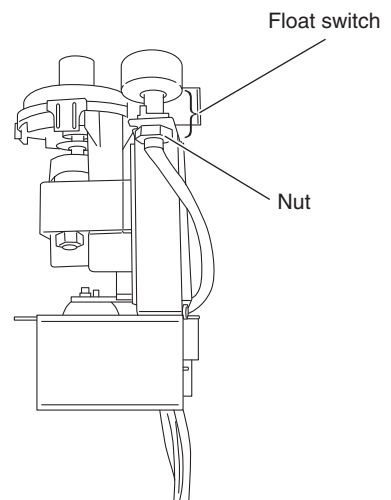

Fig.21

### 7-3-9. Remove the turbo fan and fan motor.

- (1) Remove a nut and remove the turbo fan. (Fig. 22)
- (2) Remove the 2 screws and 3 nuts, and remove the fan motor. (Fig. 23)

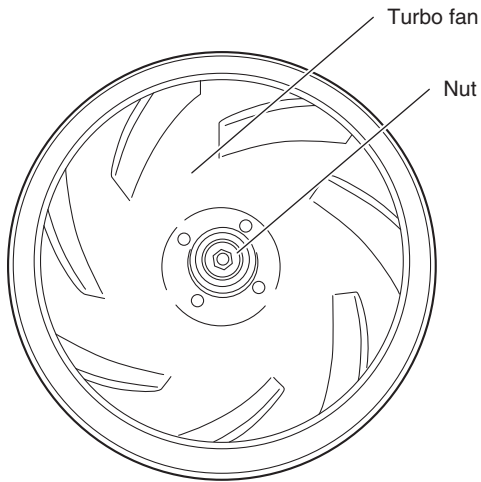

Fig.22

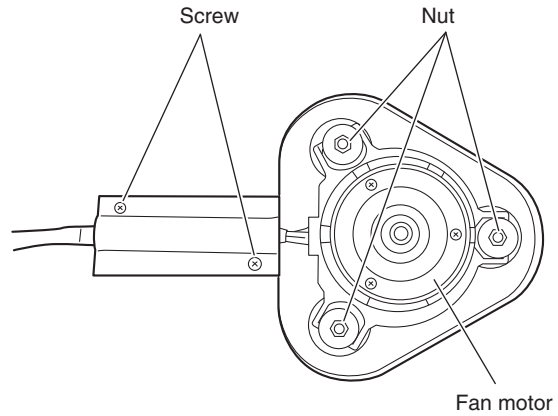

Fig.23

### 7-3-10. Remove the heat exchanger.

- (1) Remove the 3 screws. (Fig. 24)
- (2) Remove the 3 screws. (Fig. 25)
- (3) Remove the heat exchanger from the main body upper section with the heat exchanger lifted.

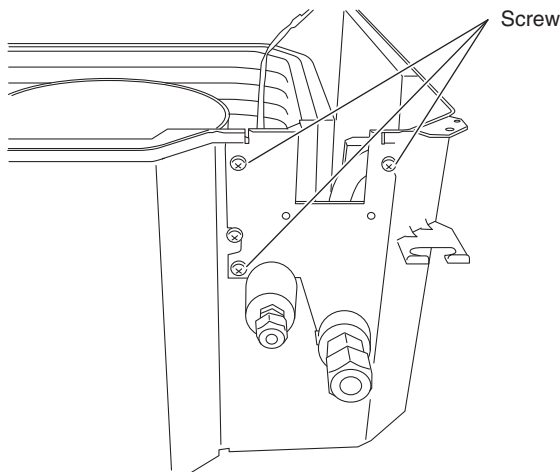

Fig.24

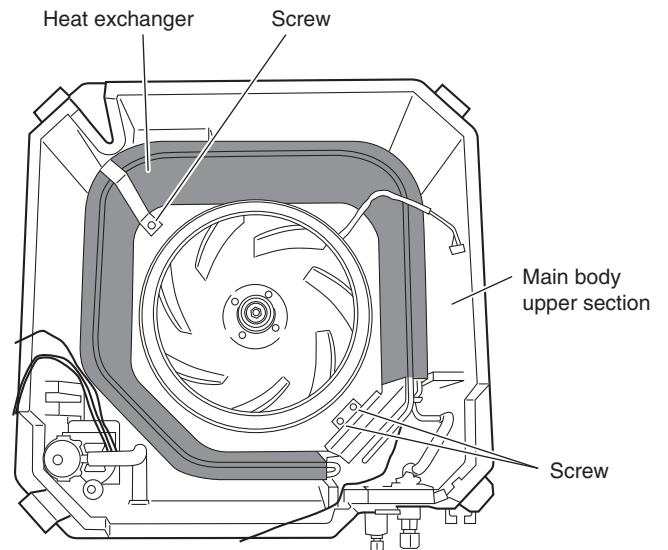

Fig.25

# 8. FUNCTIONS

## 8-1. Operation Functions

### ■ Emergency operation

Emergency operation is available when the remote controller malfunctions, has been lost, or otherwise cannot be used.

To operate the system, press the OPERATION button, which is also used as the receiver, below the unit display. Each time this button is pressed, the OPERATION lamp changes color to indicate the type of operation. Select the desired type of operation.



- The set temperature is 4°F(2°C) below the detected room temperature in the case of cooling operation.

### ■ SENSOR DRY

During DRY operation, the system adjusts the room temperature and fan speed according to the conditions in the room, in order to maintain a comfortable room environment.

#### SENSOR DRY operation

- DRY operation is as shown in the figure below.

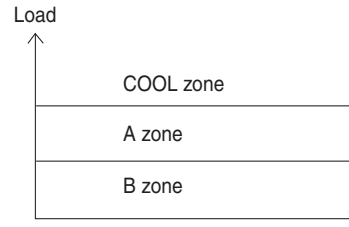

Conditions are monitored at all times when the room temperature is below 59°F(15°C).

#### DRY A

The compressor operation frequency varies.  
The indoor fan operates with 1/f fluctuation.

#### DRY B

The compressor operates at a low operating frequency.  
The indoor fan operates with 1/f fluctuation.

#### Monitor

- Monitoring operation takes place when the room temperature is below 59°F(15°C), or more than 5°F(3°C) below the set temperature.
- When the monitoring range is entered, the compressor stops, and the indoor fan operates with 1/f fluctuation.

#### NOTE (CLxx models only)

The Sensor Dry operation during the Low Ambient Cooling Mode (outside air temperature:59°F(15°C) or lower) is as follows.

#### DRY A and DRY B

The compressor operates a cycle of 3 minutes ON and 6 minutes OFF repeatedly.

### ■ PAM-α control

- In order to further improve inverter performance, control is switched between PWM control at low operation speeds, and PAM control at high operation speeds, making the most effective use of power.



## ■ HIGH POWER

This function acts to raise the power but keeps the AC system in the same operating mode. This function is set with the HIGH POWER button on the remote controller.

(It can be set regardless of the temperature and fan speed settings.)

### ● HIGH POWER operation from remote controller

The unit operates at maximum output for 30 minutes, regardless of the desired temperature. The fan speed is 1 step above "High."

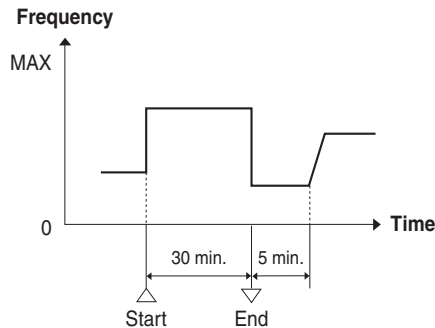

### NOTE

- When HIGH POWER operation ends, the unit operates at low Hz for 5 minutes, regardless of the thermostat OFF conditions.
- When in DRY mode, operation is in the cooling zone.

## ■ NIGHT SETBACK

- When NIGHT SETBACK operation is set, the temperature and fan speed settings will be adjusted automatically to allow comfortable sleep.
- When NIGHT SETBACK operation is set, "☺" mark appears on the remote controller. The main unit display lamp also becomes dimmer.

### ● COOL and DRY modes

When the night setback mode is selected, the air conditioner automatically raises the temperature setting  $2^{\circ}\text{F}(1^{\circ}\text{C})$  when 30 minutes have passed after the selection was made, and then another  $2^{\circ}\text{F}(1^{\circ}\text{C})$  after another 30 minutes have passed, regardless of the indoor temperature when night setback was selected. This enables you to save energy without sacrificing comfort. This function is convenient when gentle cooling is needed.

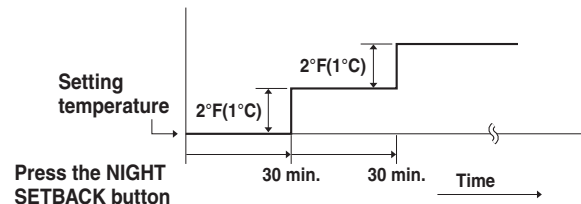

## ■ Lamp colors

### OPERATION lamp

DRY operation	Orange
COOL operation	Green
FAN operation	Green

### OPERATION lamp

Green

### TIMER lamp

Green

### HIGH POWER lamp

Green

## ■ Timer backup

- Operation stops if there are no operator controls for 25 hours or longer after unit operation switched from OFF to ON by use of ON timer operation.

## 8-2. Protective Functions

### ■ Freeze prevention

During COOL or DRY operation, freezing is detected and operation is stopped when the temperature of the indoor heat exchanger matches the conditions below.

- Freeze-prevention operation is engaged when the temperature of the indoor heat exchanger is below 43°F(6°C).
- Restart after freeze-prevention operation occurs when the temperature of the indoor heat exchanger reaches 46°F(8°C) or above.

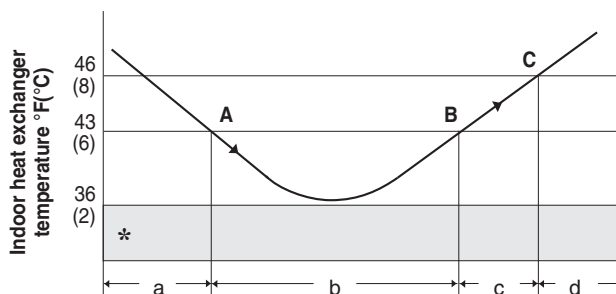

- Area: Automatic capacity control
- When the temperature drops below Point A, the operation frequency is reduced by a certain proportion.
- Area: Frequency increase is prohibited.
- When the temperature reaches Point C or above, freezing prevention is ended and control is the same as in the a area.

\* When the temperature drops to below 36°F(2°C) (continuously for 2 minutes or longer), the compressor stops. Once the freeze condition is detected, the air conditioner will work less than the maximum frequency until it is turned off.

#### NOTE (CLxx models only)

The Freeze Prevention Control during the Low Ambient Cooling Mode (outside air temperature:59°F(15°C) or lower) is as follows.

- The compressor stops when the temperature of indoor heat exchanger becomes less than 36°F(2°C).
- The compressor restarts when the temperature of indoor heat exchanger becomes 46°F(8°C) or higher.

### ■ Compressor discharge temperature control

This function controls the operation frequency to prevent the compressor discharge temperature from rising more than a specified temperature.

#### Compressor discharge temperature °F(°C)

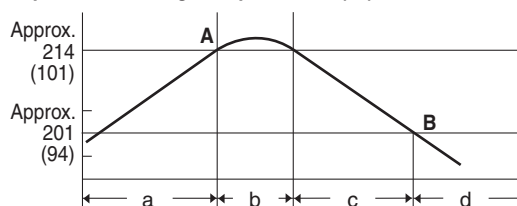

- Area: Automatic capacity control.
- When the temperature rises above Point A, the operation frequency is reduced at a specified rate.
- Area: Further frequency increase is prohibited.
- When the temperature falls below Point B, prevention of a rise in frequency is released and the air conditioner operates as in a area.

\* The compressor will stop if the temperature of the compressor discharge exceeds 248°F(120°C) due to shortage of gas or other reason.

### ■ CT (Peak current cut-off control)

- This function prevents the circuit breaker or fuse from operating to open the circuit. This function works when electrical current has increased due to an increase in the cooling load, or to a decrease in the power supply voltage. In these cases, operation frequency is reduced or operation is interrupted automatically to control the electrical current for operation.
- When the cause of the increase in electrical current is rectified, the system will resume operation in the original mode.

<CS-KS12NB41> (A)

	Cooling • Dry
Peak current cut-off trips	22.5
Hz down	14.0

<CS-KS18NB4UW> (A)

	Cooling • Dry
Peak current cut-off trips	17.5
Hz down	11.0

# 9. TROUBLESHOOTING (BEFORE CALLING FOR SERVICE)

## 9-1. Precautions before Performing Inspection or Repair

- After checking the self-diagnostics monitor, turn the power OFF before starting inspection or repair.
  - High-capacity electrolytic capacitors are used inside the outdoor unit controller (inverter). They retain an electrical charge (charging voltage DC 310V) even after the power is turned OFF, and some time is required for the charge to dissipate. Be careful not to touch any electrified parts before the controller LED (red) turns OFF.
- If the outdoor controller is normal, approximately 30 seconds will be required for the charge to dissipate. However, allow at least 5 minutes for the charge to dissipate if there is thought to be any trouble with the outdoor controller.

## 9-2. Method of Self-Diagnostics

Follow the procedure below to perform detailed trouble diagnostics.

### NOTE

- 1: If the operation lamp blinks every 0.5 seconds immediately when the power is turned ON, there is an external ROM (OTP data) failure on the indoor circuit board, or a ROM socket insertion problem, or the ROM has not been installed.
- 2: The failure mode is stored in memory even when the power is not ON. Follow the procedure below to perform diagnostics.

### PROCEDURE

After turning on power to the air conditioner, use the remote controller and follow the steps below to execute self-diagnostics.

- Step 1: Press and hold the remote controller HIGH POWER button and 1 HR TIMER button. Then, press and hold the ACL (reset) button with a pointed object such as the tip of a pen. After 5 seconds, release ACL button first, then release HIGH POWER and 1 HR TIMER buttons, "oP-1" (test run) appears, blinking in the remote controller clock display area.
- Step 2: Next, press the 1 HR TIMER button once to change the display from "oP-1" to "oP-3" (self-diagnostics). (The display continues to blink.)
- Step 3: Finally press the ON/OFF button to engage self-diagnostics mode.

- The self-diagnostics function utilizes the 3 indicator lamps on the main unit, in combinations of ON lamps, blinking lamps, and OFF lamps, to report the existence of sensor trouble or a protective operation. (The lamps blink or remain ON for 5 seconds, then turn OFF for 2 seconds.) Self-diagnostics is completed when the buzzer sounds 3 short beeps.
- A maximum of 3 self-diagnostics reports are displayed, for 5 seconds each, beginning with the most recent report. Following this display the lamps turn OFF. In order to view the self-diagnostics results again, press the ON/OFF button again.
- The 3 lamps remain OFF if no trouble has occurred.

<IMPORTANT> After self-diagnostics is completed, be sure to press the ACL (reset) button to return to normal mode. The air conditioner will not operate if this is not done.

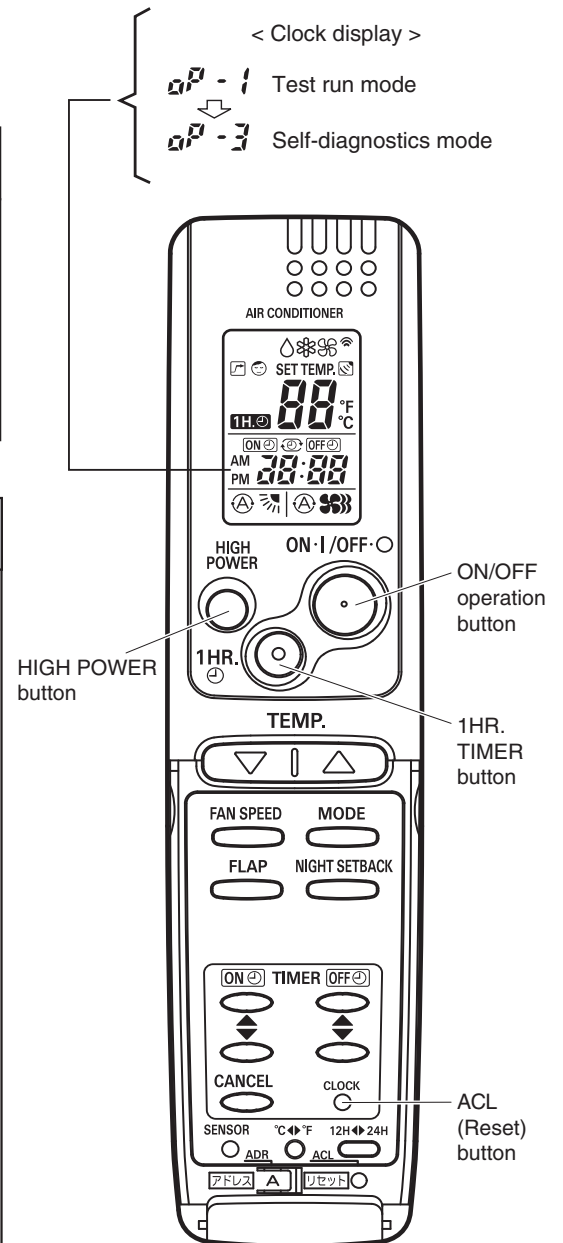

## (1) Self-diagnostics Lamps

### INDOOR UNIT

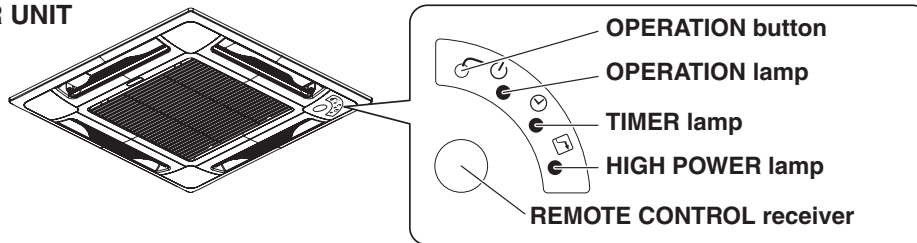

• Since the indications cover various units, the corresponding parts listed below may not be present in some models.

INDICATION ON INDOOR UNIT			× ... OFF    ● ... BLINKING    ☀ ... ON		
OPERATION	TIMER	HIGH POWER	CODE	DIAGNOSIS CONTENTS	POSSIBLE MALFUNCTION
●	×	×	S01	ROOM TEMP. SENSOR TROUBLE	(1) OPEN OR SHORT CIRCUIT IN SENSOR (2) POOR CONTACT AT CONNECTOR OR OPEN CIRCUIT AT TERMINAL PRESS-FIT LOCATION. (3) I/D PCB FAILURE (I/D = INDOOR)
×	●	×	S02	I/D HEAT EXCHANGER TEMP. SENSOR TROUBLE	
×	×	●	S04	COMPRESSOR TEMP. SENSOR TROUBLE	
●	×	●	S05	O/D HEAT EXCHANGER TEMP. SENSOR TROUBLE	(1) OPEN OR SHORT CIRCUIT IN SENSOR (2) POOR CONTACT AT CONNECTOR OR OPEN CIRCUIT AT TERMINAL PRESS-FIT LOCATION (3) O/D PCB FAILURE (O/D = OUTDOOR)
×	●	●	S06	O/D AIR TEMP. SENSOR TROUBLE	
●	●	●	S07	O/D CURRENT SENSOR ERROR	
☀	×	×	E01	I/D-O/D COMMUNICATION TROUBLE (SERIAL COMMUNICATION TROUBLE)	(1) MIS-WIRING (2) AC POWER FAILURE (3) BLOWN FUSE (4) POWER RELAY FAILURE (5) I/D OR O/D PCB FAILURE (6) O/D FAN MOTOR FAILURE (7) REACTOR FAILURE (8) HIGH-PRESSURE SW FAILURE (9) OLR FAILURE (10) MAGNETIC COIL FAILURE
×	☀	×	E02	HIC CIRCUIT TROUBLE POWER TR CIRCUIT TROUBLE	(1) HIC OR POWER TR FAILURE (2) O/D FAN NOT OPERATING (3) INSTANTANEOUS POWER STOPPAGE (4) SERVICE VALVE NOT OPENED (5) O/D FAN BLOCKED (6) CONTINUOUS OVERLOAD OPERATION (7) COMPRESSOR FAILURE (8) O/D PCB FAILURE
☀	☀	×	E03	O/D UNIT EXTERNAL ROM TROUBLE	(1) EXTERNAL ROM DATA FAILURE (2) O/D PCB FAILURE
×	×	☀	E04	CURRENT PEAK CUT	(1) INSTANTANEOUS POWER STOPPAGE (2) HIC OR POWER TR FAILURE (3) O/D PCB FAILURE
☀	×	☀	E05	PAM CIRCUIT TROUBLE ACTIVE CIRCUIT TROUBLE	(1) O/D PCB FAILURE (2) O/D POWER VOLTAGE TROUBLE
×	☀	☀	E06	COMPRESSOR DISCHARGE TEMP. OVERHEATING PREVENTION	(1) ELECTRIC EXPANSION VALVE FAILURE (2) CHOKED CAPILLARY TUBE (3) INSUFFICIENT GAS (4) CONTINUOUS OVERLOAD OPERATION (5) O/D FAN NOT OPERATING (6) O/D PCB FAILURE
☀	☀	☀	E07	I/D FAN OPERATION TROUBLE	(1) FAN MOTOR FAILURE (2) CONNECTOR CONTACT FAILURE (3) I/D PCB FAILURE
☀	●	●	E08	4-WAY VALVE SWITCHING TROUBLE ZERO-CROSS TROUBLE	(1) 4-WAY VALVE FAILURE (HEAT PUMP MODEL ONLY) (2) O/D PCB FAILURE
●	☀	●	E09	GAS-LOSS PREVENTION	(1) SERVICE VALVE NOT OPENED (2) INSUFFICIENT GAS
☀	☀	●	E10	DC COMPRESSOR DRIVE CIRCUIT TROUBLE	(1) OPEN PHASE (2) O/D PCB FAILURE
●	●	☀	E11	O/D DC FAN OPERATION TROUBLE	(1) FAN MOTOR FAILURE (2) CONNECTOR CONTACT FAILURE (3) O/D PCB FAILURE
☀	●	☀	E12	O/D SYSTEM COMM FAILURE, OLR OPERATION, O/D POWER OPEN PHASE, O/D FREEZING	(1) MIS-WIRING (2) BLOWN FUSE (3) POWER RELAY FAILURE (4) O/D PCB FAILURE (5) COMPRESSOR FAILURE
●	☀	☀	E13	FREEZING-PREVENTION OPERATION	(1) I/D FAN SYSTEM TROUBLE (2) INSUFFICIENT GAS (3) OPERATION AT LOW TEMPERATURE
TIMER LAMP	⊖ BLINKING (3 SEC. INTERVAL)			FLOAT SWITCH (FS) IS ACTIVATED.	(1) DRAIN PUMP FAILURE (2) FS FAILURE (3) CHOKED DRAIN HOSE

8512-5261-99100-1

**(2) If the self-diagnostics function fails to operate**

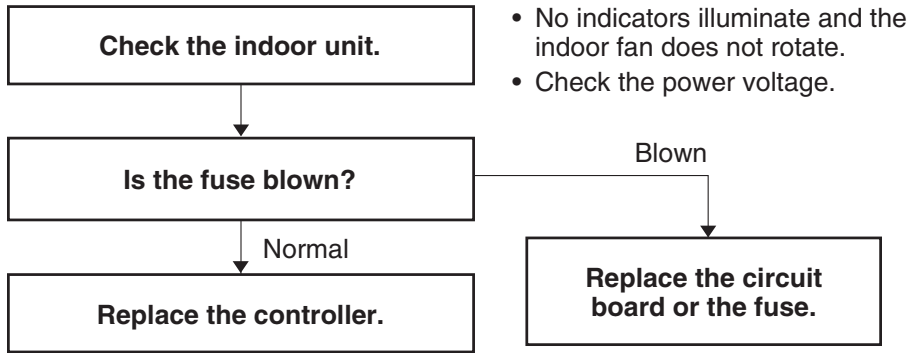

**9-3. Checking the Indoor and Outdoor Units**

**(1) Checking the indoor unit**

No.	Control	Check items (unit operation)
1	Use the remote controller to operate the unit in "TEST run" mode. To determine whether the mode is currently in "TEST run" mode, check the 3 indicator lamps on the unit. If all 3 are blinking, the current mode is "TEST run."	<ul style="list-style-type: none"> <li>The rated voltage must be present between inter-unit wirings 1 and 2.</li> <li>Connect a 5 k ohm resistor between inter-unit wirings 2 and 3. When the voltage at both ends is measured, approximately 12 to 15V DC must be output and the multimeter pointer must bounce once every 8 seconds.</li> </ul> Or instead of measuring the voltage, you can insert an LED jig and check that the LED flickers once every 8 seconds.

- If there are no problems with the above, then check the outdoor unit.
- For the "Test run" procedure, refer to the Appendix B "Installation Instructions".

**(2) Checking the outdoor unit**

No.	Control	Check items (unit operation)
1	Apply the rated voltage between outdoor unit terminals L and N.	• The control panel LED (red) must illuminate.
2	Short-circuit the outdoor unit COM terminal to the T-RUN terminal.	• The compressor, fan motor and 4-way valve must all turn on.

- If there are no problems with the above, then check the indoor unit.

**● Using the TEST/T-RUN terminals**

T-RUN : Test run (compressor and fan motor turn ON).  
 TEST/MV : Compresses time to 1/60th (accelerates operation by 60 times faster than normal).

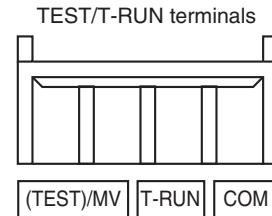

### (3) Serial Communication Error Identification Procedure

If the lamps on the main body show the following conditions after the completion of self-diagnostics, a communication error between the indoor unit and outdoor unit might be considered. In such a case, identify the breakdown section by using the following procedure.

**NOTE** Refer to "Method of Self-Diagnostics" for the self-diagnostics procedure.

Condition \ Lamp	Operation	Timer	High Power
E01		×	×
E12			

× : Off  
 : Blinking  
 : Illuminated

#### < Before the Operation >



#### WARNING

For terminal strip short circuit work or inter-unit wiring removal, turn off the power to avoid an electric shock. Release the terminal strip short circuit after the completion of self-diagnostics.



#### CAUTION

Do not perform the short-circuit work between any other terminals except for specified ones on the specified terminal strip. If such work is performed between the incorrect terminals, the unit might be broken.

#### < Convenient Tool for Short-Circuit Work ( for example ) >

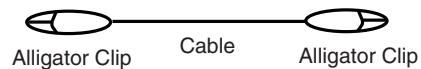

#### < Check Items before Troubleshooting Serial Communication Start >

After confirming that the following errors do not exist, start the "Troubleshooting Serial Communication" in "Condition: E01 and E12".

- |   |  |
|---|--|
| 1. Mis -wiring (inter-unit cable, etc.)                   | 6. Reactor failure (defective insulation, etc.)                      |
| 2. AC power failure                                       | 7. High-Pressure Switch failure                                      |
| 3. Blown fuse   | 8. Overload Relay failure  |
| 4. Power Relay failure                                    | 9. Magnetic Coil failure (defective insulation, short-circuit, etc.) |
| 5. Outdoor Fan Motor failure (defective insulation, etc.) | 10. Compressor failure (defective insulation, etc.)                  |

#### (3-1) Condition: E01

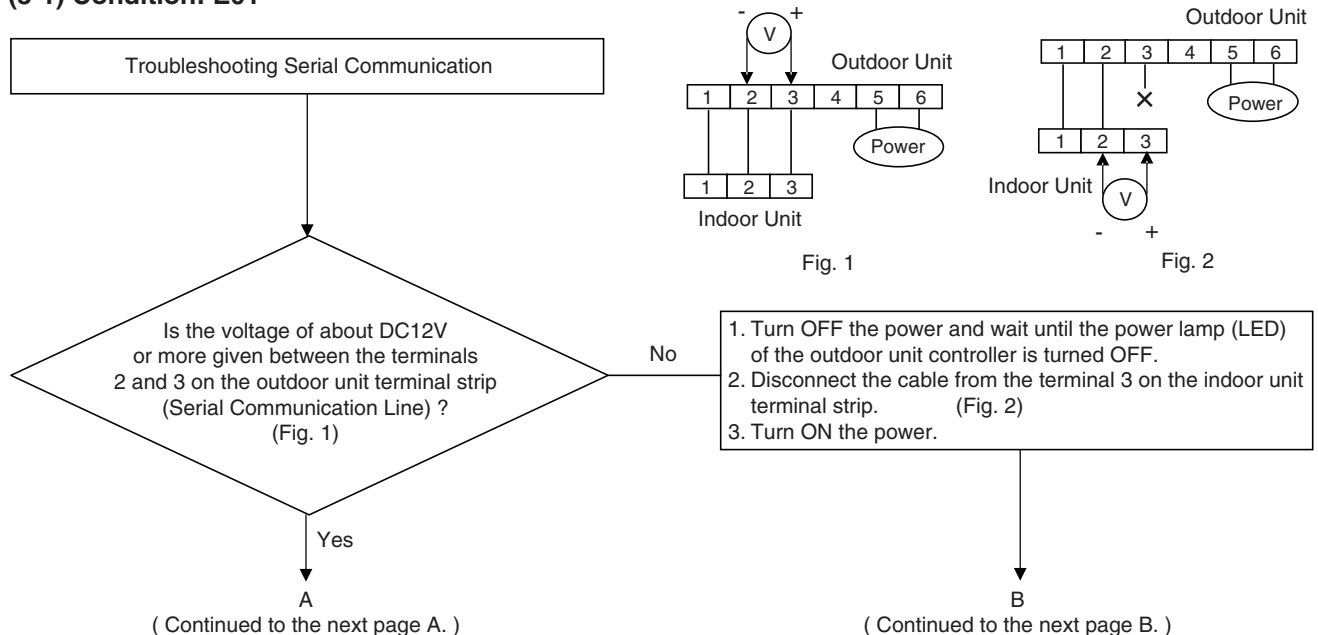

( Continued from the previous page A. )

( Continued from the previous page B. )

A

B

Yes

No

Defect or connection error in the inter-unit cable

Defect in the indoor unit P.C. board

1. Turn OFF the power and wait until the power lamp (LED) of the outdoor unit controller is turned OFF.  
 2. Short-circuit between the terminals 2 and 3 on the outdoor unit terminal strip. (Fig. 3)

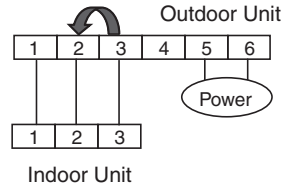

Fig. 3

1. Turn ON the power and operate the system using the remote controller or the operation button on the indoor unit.  
 2. Perform the self-diagnosis five seconds after the operation start.



Condition: E12

Defect in the outdoor unit P.C. board.

Condition: E01

1. Turn off the power and wait until the power lamp (LED) of the outdoor unit controller is turned OFF.  
 2. Remove the short-circuit between the terminals 2 and 3 on the outdoor unit terminal strip.  
 3. Disconnect the cable from the terminal 3 on the indoor unit terminal strip. (Fig. 4)

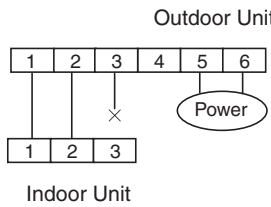

Fig. 4

Short-circuit between the terminals 2 and 3 on the indoor unit terminal board. (Fig. 5)

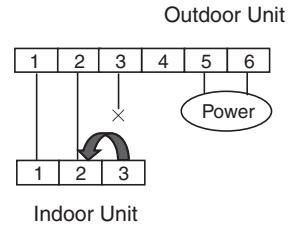
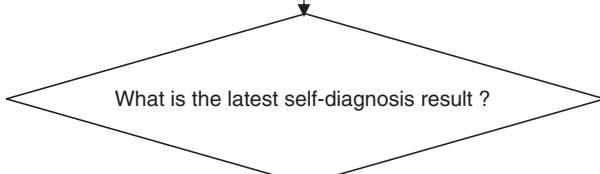

Fig. 5

1. Turn ON the power and operate the system using the remote controller or the operation button on the indoor unit.  
 2. Perform the self-diagnosis five seconds after the operation start.



Condition: E12

Defect or connection error in the inter-unit cable

Condition: E01

Defect in the indoor unit P.C. board

**(3-2) Condition: E12**

Troubleshooting Serial Communication

1. Turn off the power and wait until the power lamp (LED) of the outdoor unit controller is turned OFF.
2. Disconnect the cable from the terminal 3 on the Outdoor unit terminal strip. (Fig. 6)

1. Turn ON the power and operate the system using the remote controller or the operation button on the indoor unit.
2. Perform the self-diagnosis five seconds after the operation start.

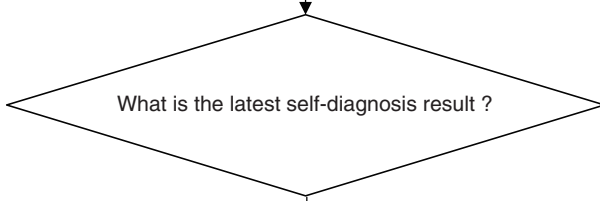

Condition: E01 → Defect in the outdoor unit P.C. board

Condition: E12

1. Turn off the power and wait until the power lamp (LED) of the outdoor unit controller is turned OFF.
2. Disconnect the cable from the terminal 3 on the indoor unit terminal strip. (Fig. 7)

1. Turn ON the power and operate the system using the remote controller or the operation button on the indoor unit.
2. Perform the self-diagnosis five seconds after the operation start.

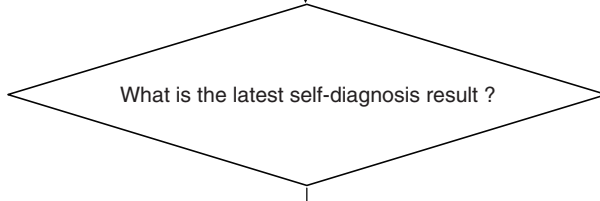

Condition: E01 → Defect in the inter-unit cable

Condition: E12

Defect in the indoor unit P.C. board

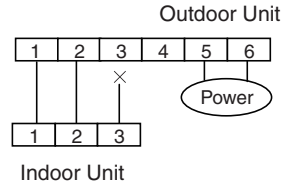

Fig. 6

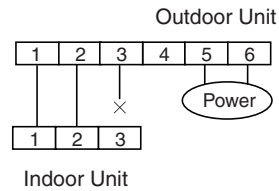

Fig. 7



## 9-4. Trouble Diagnosis of Fan Motor

### 9-4-1. Indoor Fan Motor

- This indoor DC fan motor contains an internal control PCB. Therefore, it is not possible to measure the coil resistance, and the following procedure should be used to check the motor.
- To perform diagnosis, operate the unit in cooling mode with indoor fan speed "High". Next, make sure that the indoor unit receive the signals from the remote controller when the ON/OFF operation button is pressed.

**Important:** (A) Turn OFF the power before connecting or disconnecting the motor connectors.  
 (B) When performing voltage measurement at the indoor controller connector for (3) in the table below, the DC motor will trip and voltage output will stop approximately 1 minute after operation is started. For this reason, to measure the voltage again, turn OFF the unit once using the remote controller, and then start the air conditioner again.

[Trouble symptom 1] The fan does not stop when the unit stops. →Indoor unit controller trouble.

[Trouble symptom 2] The fan motor does not rotate when the unit is operating.

**(Diagnostic procedure)**

\* Disconnect the motor connectors and measure the voltage at the DC motor connectors on the indoor unit controller (3 locations).

Measurement location	Normal value	
	CS-KS12NB41	CS-KS18NB4UW
(1) Vm-Gnd: Between pin 1 and pin 3	DC 130V to 195V	DC 280V to 340V
(2) Vcc-Gnd: Between pin 4 and pin 3	DC 15V +/- 10%	
(3) Vs-Gnd: Between pin 5 and pin 3	Fluctuation between DC 1.8V to 5.7V	

**(Diagnostic results)**

All of the above measured values are normal. →Fan motor trouble (Replace the motor.)

Any one of the above measured values is not normal. →Indoor unit controller trouble (Replace the controller .)

**(Reference)** DC motor connector pin arrangement

- Pin 1: Vm (red)
- Pin 2: Not used
- Pin 3: Gnd (black)
- Pin 4: Vcc (white)
- Pin 5: Vs (yellow)
- Pin 6: PG (blue)

[Trouble symptom 3] Motor rotates for some time (several seconds), but then quickly stops, when the indoor unit operates.

(There is trouble in the system that provides feedback of motor rotation speed from the motor to the indoor unit controller.)

[Trouble symptom 4] Fan motor rotation speed does not change during indoor unit operation.

[Trouble symptom 5] Fan motor rotation speed varies excessively during indoor unit operation.

**(Remedy for symptom 3 to 5)**

It is not possible to identify whether the trouble is indoor unit controller trouble or motor trouble. Therefore, first replace the indoor unit controller, then (if necessary) replace the DC motor.

## 9-4-2. Outdoor Fan Motor

- This outdoor DC fan motor contains an internal control PCB. Therefore, it is not possible to measure the coil resistance, and the following procedure should be used to check the motor.
- Perform the trouble diagnosis by Test Run mode described on Installation Instructions.

**Important:** (A) Turn OFF the power before connecting or disconnecting the motor connectors.  
 (B) When performing voltage measurement at the outdoor controller connector for (3) in the table below, the DC motor will trip and voltage output will stop approximately 10 seconds after operation is started. For this reason, to measure the voltage again, first turn OFF the outdoor unit power, then, measure the voltage in Test Run mode.

[Trouble symptom 1] The fan does not stop when the outdoor unit stops. → Outdoor unit controller trouble

[Trouble symptom 2] The fan motor does not rotate when the outdoor unit is operating.

**(Diagnostic procedure)**

\* Disconnect the motor connectors and measure the voltage at the DC motor connectors on the outdoor unit controller (3 locations).

Measurement location	Normal value
(1) Vs-Gnd: Between pin 1 and pin 4	DC 110V or more
(2) Vcc-Gnd: Between pin 5 and pin 4	DC 14V or more
(3) Vsp-Gnd: Between pin 7 and pin 4	After fluctuating 4 times between DC 1.0 to 4.3V (1 sec. ON) and DC 0 V (1 sec. OFF), the DC motor trips.

**(Diagnostic results)**

All of the above measured values are normal. → Fan motor trouble (Replace the motor.)

Any one of the above measured values is not normal. → Outdoor unit controller trouble  
 (Replace the controller.)

**(Reference)** DC motor connector pin arrangement

- Pin 1: Vs (white)
- Pin 2: Not used
- Pin 3: Not used
- Pin 4: Gnd (black)
- Pin 5: Vcc (red)
- Pin 6: FG (blue)
- Pin 7: Vsp (yellow)

[Trouble symptom 3] Motor rotates for some time (several seconds), but then quickly stops, when the outdoor unit operates.

(There is trouble in the system that provides feedback of motor rotation speed from the motor to the outdoor unit controller.)

[Trouble symptom 4] Fan motor rotation speed does not change during outdoor unit operation.

[Trouble symptom 5] Fan motor rotation speed varies excessively during outdoor unit operation.

**(Remedy for symptom 3 to 5)**

It is not possible to identify whether the trouble is outdoor unit controller trouble or motor trouble. Therefore, first replace the outdoor unit controller, then (if necessary) replace the DC motor.

## 9-5. Noise Malfunction and Electromagnetic Interference

An inverter A/C operates using pulse signal control and high frequencies. Therefore, it is susceptible to the effects of external noise, and is likely to cause electromagnetic interference with nearby wireless devices.

A noise filter is installed for ordinary use, preventing these problems. However, depending on the installation conditions, these effects may still occur. Please pay attention to the points listed below.

### (1) Noise malfunction

This refers to the application of high-frequency noise to the signal wires, resulting in abnormal signal pulses and malfunction.

Locations most susceptible to noise	Trouble	Correction
<ol style="list-style-type: none"> <li>Locations near broadcast stations where there are strong electromagnetic waves</li> <li>Locations near amateur radio (short wave) stations</li> <li>Locations near electronic sewing machines and arc-welding machines</li> </ol>	<p>Either of the following trouble may occur.</p> <ol style="list-style-type: none"> <li>The unit may stop suddenly during operation.</li> <li>Indicator lamps may flicker.</li> </ol>	<p>(The fundamental concept is to make the system less susceptible to noise.)</p> <p>- Insulate for noise or distance from the noise source. -</p> <ol style="list-style-type: none"> <li>Use shielded wires.</li> <li>Move unit away from the noise source.</li> </ol>

### (2) Electromagnetic interference

This refers to noise generated by high-speed switching of the microcomputer and compressor. This noise radiates through space and returns to the electric wiring, affecting any wireless devices (televisions, radios, etc.) located nearby.

Locations most susceptible to noise	Trouble	Correction
<ol style="list-style-type: none"> <li>A television or radio is located near the A/C and A/C wiring.</li> <li>The antenna cable for a television or radio is located close to the A/C and A/C wiring.</li> <li>Locations where television and radio signals are weak.</li> </ol>	<ol style="list-style-type: none"> <li>Noise appears in the television picture, or the picture is distorted.</li> <li>Static occurs in the radio sound.</li> </ol>	<ol style="list-style-type: none"> <li>Select a separate power source.</li> <li>Keep the A/C and A/C wiring at least 1 meter away from wireless devices and antenna cables.</li> <li>Change the wireless device's antenna to a high-sensitivity antenna.</li> <li>Change the antenna cable to a BS coaxial cable.</li> <li>Use a noise filter (for the wireless device).</li> <li>Use a signal booster.</li> </ol>

# 10. CHECKING ELECTRICAL COMPONENTS

## 10-1. Measurement of Insulation Resistance

- The insulation is in good condition if the resistance exceeds 1M ohm.

### 10-1-1. Power Supply Cord

Clamp the grounding wire of power cord with the lead clip of the insulation resistance tester and measure the resistance by placing a probe on either of the two power wires. (Fig. 1)

Then also measure the resistance between the grounding and other power terminals. (Fig. 1)

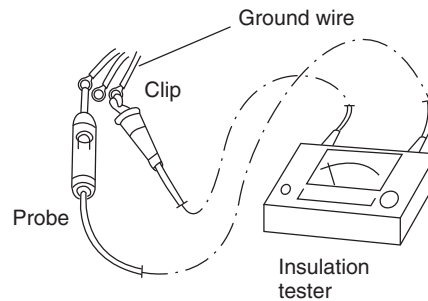

Fig. 1

### 10-1-2. Indoor Unit

Clamp an aluminum plate fin or copper tube with the lead clip of the insulation resistance tester and measure the resistance by placing a probe on each terminal screw on the terminal plate. (Fig. 2)

Note that the ground line terminal should be skipped for the check.

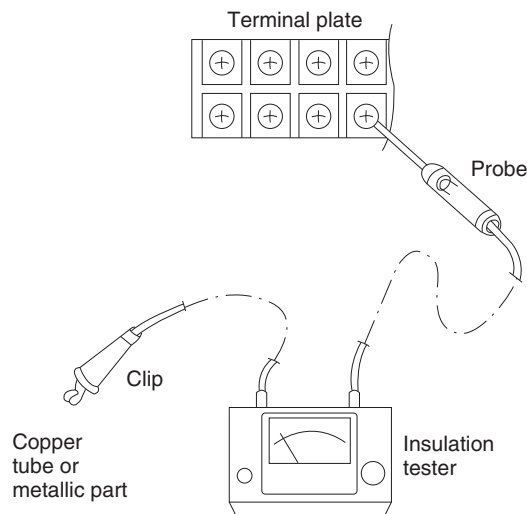

Fig. 2

### 10-1-3. Outdoor Unit

Clamp a metallic part of the unit with the lead clip of the insulation resistance tester and measure the resistance by placing a probe on each terminal screw where power supply lines are connected on the terminal plate. (Fig. 2)

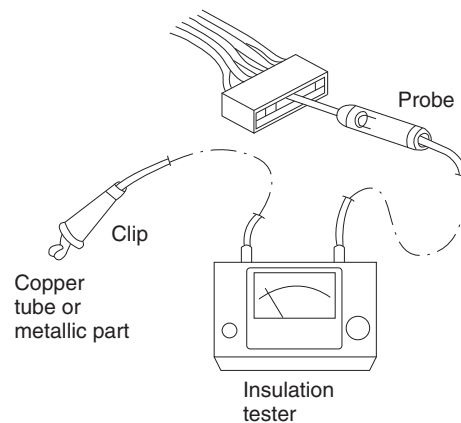

Fig. 3

### 10-1-4. Measurement of Insulation Resistance for Electrical Parts

Disconnect the lead wires of the desired electric part from terminal plate, capacitor, etc. Similarly disconnect the connector. Then measure the insulation resistance. (Figs. 3 and 4)

#### NOTE

Refer to Electric Wiring Diagram.

If the probe cannot enter the poles because the hole is too narrow then use a probe with a thinner pin.

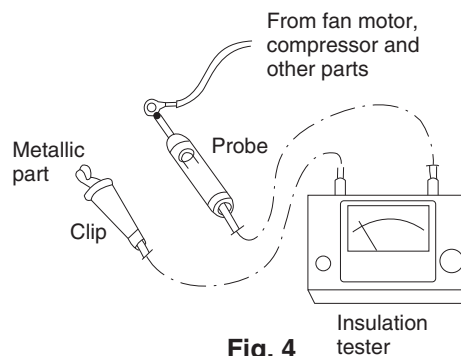
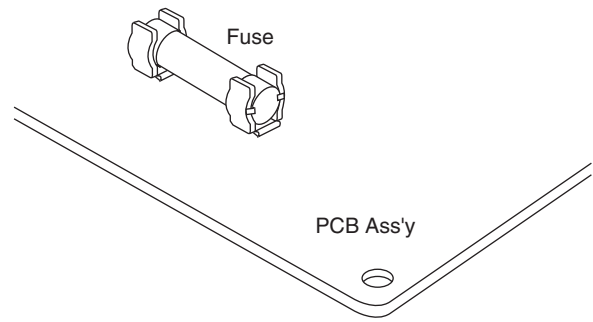

Fig. 4

## 10-2. Checking Continuity of Fuse on PCB Ass'y

- Remove the PCB Ass'y from the electrical component box. Then pull out the fuse from the PCB Ass'y. (Fig. 5)
- Check for continuity using a multimeter as shown in Fig. 6.



**Fig. 5**

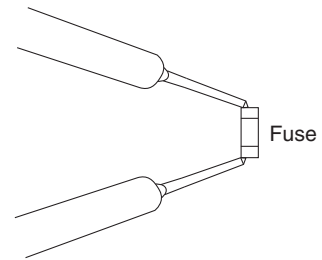

**Fig. 6**

# 11. REFRIGERANT R410A: SPECIAL PRECAUTIONS WHEN SERVICING UNIT

## 11-1. Characteristics of New Refrigerant R410A

### 11-1-1. What is New Refrigerant R410A?

R410A is a new refrigerant that contains two types of pseudo-non-azeotropic refrigerant mixture. Its refrigeration capacity and energy efficiency are about the same level as the conventional refrigerant, R22.

### 11-1-2. Components (mixing proportions)

HFC32 (50%) / HFC125 (50%)

### 11-1-3. Characteristics

- Less toxic, more chemically stable refrigerant
- The composition of refrigerant R410A changes whether it is in a gaseous phase or liquid phase. Thus, when there is a refrigerant leak the basic performance of the air conditioner may be degraded because of a change in composition of the remaining refrigerant. **Therefore, do not add new refrigerant.** Instead, recover the remaining refrigerant with the refrigerant recovery unit. Then, after evacuation, totally recharge the specified amount of refrigerant with the new refrigerant at its normal mixed composition state (in liquid phase).
- When refrigerant R410A is used, the composition will differ depending on whether it is in gaseous or liquid phase, and the basic performance of the air conditioner will be degraded if it is charged while the refrigerant is in gaseous state. **Thus, always charge the refrigerant while it is in liquid phase.**



CAUTION

**Ether-type oil is used for compressor oil for R410A-type units, which is different from the mineral oil used for R22. Thus more attention to moisture prevention and faster replacement work compared with conventional models are required.**

## 11-2. Checklist before Servicing

Use a clutch-type flare tool for R410A or the conventional flare tool. Note that sizes of the resultant flares differ between these two tools. Where a conventional flare tool is used, make sure to observe A Specification (amount of extrusion) by using the flare spacer.

Diameter of tube D	Specification A	
	Flare tool for R410A	Conventional flare tool (for R22)
Dia. 1/4" (6.35 mm)	0 to 0.0196" (0 to 0.5 mm)	0.0472" (1.2 mm)
Dia. 3/8" (9.52 mm)		
Dia. 1/2" (12.7 mm)		
Dia. 5/8" (15.88 mm)		

### ● Size of flare

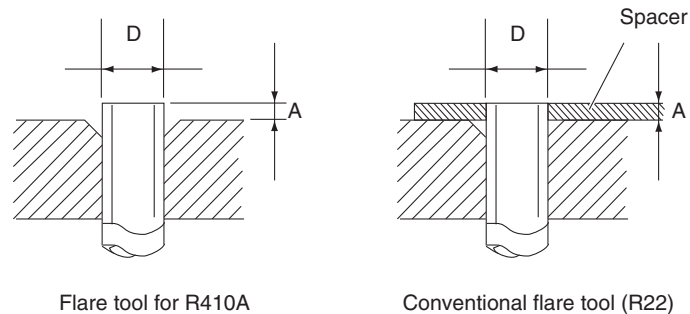

### ● Tubing precautions

- Refrigerant R410A is more easily affected by dust or moisture compared with R22, thus be sure to temporarily cover the ends of the tubing with caps or tape prior to installation.

Never use 0.0276" (0.7 mm)-thick copper tubing or tubing which is less than 0.0315" (0.8 mm) in thickness, since air conditioners with R410A are subject to higher pressure than those using R22 and R407C.

### ● No addition of compressor oil for R410A

No additional charge of compressor oil is permitted.

### ● No use of refrigerant other than R410A

Never use a refrigerant other than R410A.

### ● If refrigerant R410A is exposed to fire

Through welding, etc., toxic gas may be released when R410A refrigerant is exposed to fire. Therefore, be sure to provide ample ventilation during installation work.

### ● Caution in case of R410A leak

Check for possible leak points with the special leak detector for R410A. If a leak occurs inside the room, immediately provide thorough ventilation.

### 11-3. Tools Specifically for R410A

- For servicing, use the following tools for R410A

Tool Distinction	Tool Name
Tools specifically for R410A	<ul style="list-style-type: none"> <li>● Gauge manifold</li> <li>● Charging hose</li> <li>● Gas leak detector</li> <li>● Refrigerant cylinder</li> <li>● Charging cylinder</li> <li>● Refrigerant recovery unit</li> <li>● Vacuum pump with anti-reverse flow (*1) (Solenoid valve-installed type, which prevents oil from flowing back into the unit when the power is off, is recommended.)</li> <li>● Vacuum pump (*2)...can be used if the following adapter is attached.</li> <li>● Vacuum pump adapter (reverse-flow prevention adapter) (*3). (Solenoid valve-installed adapter attached to a conventional vacuum pump.)</li> <li>● Electronic scale for charging refrigerant</li> <li>● Flare tool</li> </ul>
Tools which can be commonly used for R22, R407C, and R410A	<ul style="list-style-type: none"> <li>● Bender</li> <li>● Torque wrench</li> <li>● Cutter, reamer</li> <li>● Welding tool, nitrogen gas cylinder</li> </ul>



**CAUTION**

- **The above tools specifically for R410A must not be used for R22 and R407C. Doing so will cause malfunction of the unit.**
- **For the above vacuum pump (\*1, \*2) and vacuum pump adapter (\*3), those for R22-type units can be used for R410A-type. However, they must be used exclusively for R410A and never alternately with R22 and R407C.**
- To prevent other refrigerants (R22, R407C) from being mistakenly charged to this unit, shape and external diameter of the service port screw has been altered.  
 <External diameter of service port> R410A : 5/16"  
 R22, R407C : 1/4"

### 11-4. Tubing Installation Procedures

When the tubes are connected, **always apply HAB oil on the flare portions to improve the sealing of tubing.**

The following is the **HAB oil** generally used:

Esso: ZERICE S32

**NOTE** For details on tubing installation procedures, refer to the installation manuals attached to the indoor unit and outdoor unit.



## 11-5. In Case of Compressor Malfunction



### CAUTION

- Should the compressor malfunction, be sure to make the switch to a replacement compressor as quickly as possible.
- Use only the tools indicated exclusively for R410A. → See "11-3. Tools Specifically for R410A."

### 11-5-1. Procedure for Replacing Compressor

#### (1) Recovering refrigerant

- Any remaining refrigerant inside the unit should not be released to the atmosphere, but recovered using the refrigerant recovery unit for R410A.
- Do not reuse the recovered refrigerant, since it will contain impurities.

#### (2) Replacing Compressor

- Soon after removing seals of both discharge and suction tubes of the new compressor, replace it quickly.

#### (3) Checking for sealing

- Use nitrogen gas for the pressurized gas, and never use a refrigerant other than R410A. Also do not use oxygen or any flammable gas.

#### (4) Evacuation

- **Use a solenoid valve-installed vacuum pump** so that even if power is cut off in the middle of evacuation of air due to a power interruption, the valve will prevent the pump oil from flowing back.
- The equipment may be damaged if moisture remains in the tubing, thus carry out the evacuation thoroughly.
- When using a vacuum pump with exhaust air volume more than 0.883 cu.ft./min. and ultimate vacuum pressure rate of 50 micron Hg.

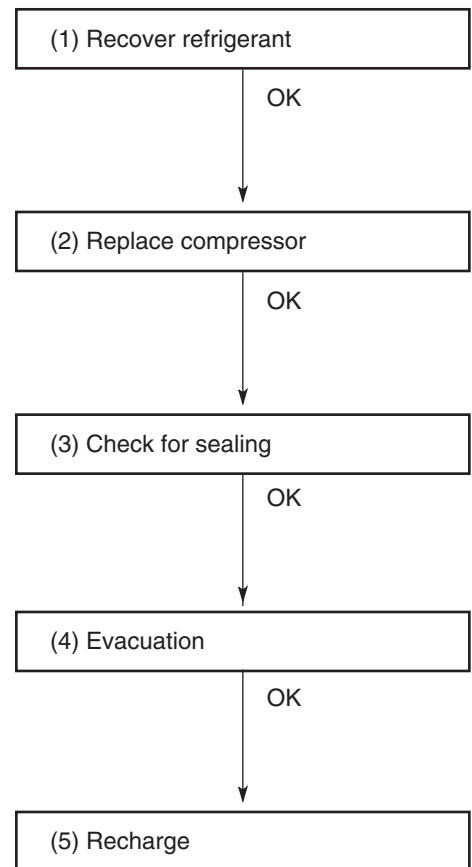

#### Standard time for evacuation

Length of tubing	Less than 33 ft. (10 m)	More than 33 ft. (10 m)
Evacuation time	More than 10 minutes	More than 15 minutes

## (5) Recharging

- **Be sure to charge the specified amount of refrigerant in liquid state** using the service port of the wide tube service valve. The proper amount is listed on the unit's nameplate.

When the entire amount cannot be charged all at once, charge gradually while operating the unit in Cooling Operation.



**CAUTION**

**Never charge a large amount of liquid refrigerant at once to the unit. This may cause damage to the compressor.**

- When charging with a refrigerant cylinder, use an electronic scale for charging refrigerant. In this case, if the volume of refrigerant in the cylinder becomes less than 20% of the fully-charged amount, the composition of the refrigerant starts to change. Thus, **do not use the refrigerant if the amount in the charging cylinder is less than 20%.**

Also, charge the minimum necessary amount to the charging cylinder before using it to charge the air conditioning unit.

### Example:

In case of charging refrigerant to a unit requiring 1.68 lb. (0.76 Kg) using a capacity of a 22 lb. (10 Kg) cylinder, the minimum necessary amount for the cylinder is:

$$1.68 + 22 \times 0.20 = 6.08 \text{ lb.}$$

$$(0.76 + 10 \times 0.20 = 2.76 \text{ Kg})$$

- **For the remaining refrigerant, refer to the instructions of the refrigerant manufacturer.**

If using a charging cylinder, transfer the specified amount of liquid refrigerant from the refrigerant cylinder to the charging cylinder.

Prepare an evacuated charging cylinder beforehand.



**CAUTION**

- **To prevent the composition of R410A from changing, never bleed the refrigerant gas into the atmosphere while transferring the refrigerant. (Fig. 3)**

**Do not use the refrigerant if the amount in the charging cylinder is less than 20%.**

## Configuration and characteristics of cylinders

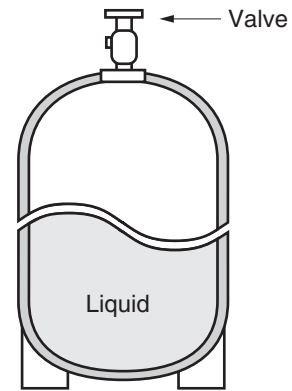

### Single valve

Charge liquid refrigerant with cylinder in up-side-down position.

**Fig. 1**

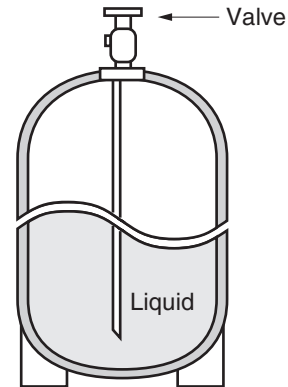

### Single valve (with siphon tube)

Charge with cylinder in normal position.

**Fig. 2**

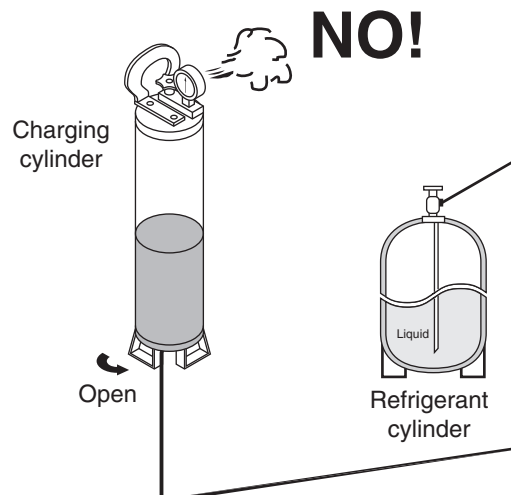

**Fig. 3**

## 11-6. In Case Refrigerant is Leaking



**CAUTION**

Never attempt to charge additional refrigerant when refrigerant has been leaking from the unit. Follow the procedure described below to locate points of leaks and carry out repairs, then recharge the refrigerant.

### (1) Detecting Leaks

- Use the detector for R410A to locate refrigerant leak points.

### (2) Recovering refrigerant

- Never release the gas to the atmosphere; recover residual refrigerant using the refrigerant recovery unit for R410A, instead.
- Do not reuse the recovered refrigerant because its composition will have been altered.

### (3) Welding leaking points

- Confirm again that no residual refrigerant exists in the unit before starting welding.
- Weld securely using flux and wax for R410A.
- Prevent oxide film from forming inside the tubes utilizing substitution with nitrogen (N<sub>2</sub>) in the refrigerant circuit of the unit. Leave ends of tubes open during welding.

### (4) Checking for sealing

- Use nitrogen gas for the pressurized gas, and never use a refrigerant other than R410A. Also do not use oxygen or any flammable gas.

### (5) Evacuation

- **Use a solenoid valve-installed vacuum pump** so that even if power is cut off in the middle of evacuation of air due to a power interruption, the valve will prevent the pump oil from flowing back.
- The equipment may be damaged if moisture remains in the tubing, thus carry out the evacuation thoroughly.
- When using a vacuum pump with exhaust air volume more than 0.883 cu.ft./min. and ultimate vacuum pressure rate of 50 micron Hg.

#### Standard time for evacuation

Length of tubing	Less than 33 ft. (10 m)	More than 33 ft. (10 m)
Evacuation time	More than 10 minutes	More than 15 minutes

### (6) Recharging

- Recharge unit in the same manner explained on the previous page "(5) Recharging."

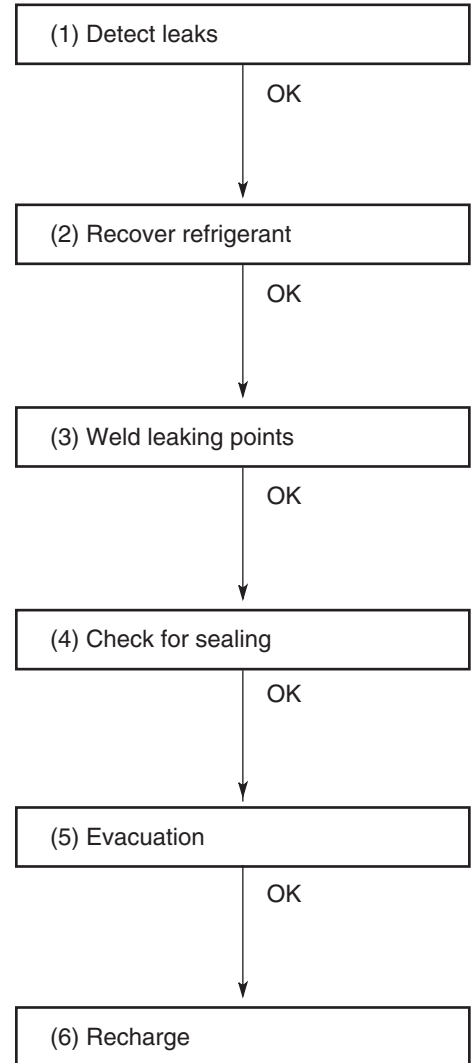

## 11-7. Charging Additional Refrigerant

### 11-7-1. When Tubes are Extended

- Observe the proper amount of refrigerant as stated in this service manual or the installation manual that came with the indoor unit. **Charge additional refrigerant in liquid state only.**



CAUTION

Never charge additional refrigerant if refrigerant is leaking from the unit. Follow instructions given in "11-6. In Case Refrigerant is Leaking" and completely carry out repairs. Only then should you recharge the refrigerant.

## 11-8. Retro-Fitting Existing Systems

### 11-8-1. Use of Existing Units

- **Never use new refrigerant R410A for existing units which use R22.** This will cause the air conditioner to operate improperly and may result in a hazardous condition.

### 11-8-2. Use of Existing Tubing

- If replacing an older unit that used refrigerant R22 with a R410A unit, **do not use its existing tubing.** Instead, completely new tubing must be used.

