



INSTALLATION INSTRUCTIONS FOR PART 88-00-2020

APPLICATIONS
STORAGE POCKET
(TO BE USED WITH INST99-2020
BUICK Regal 1988-1994)

88-00-2020
INSTALLATION INSTRUCTIONS

KIT FEATURES

- OEM Radio Replacement Pocket

KIT COMPONENTS

- A) Storage Pocket

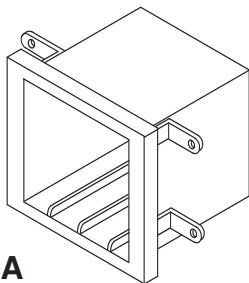

A

TOOLS REQUIRED:

- Phillips Screwdriver
- Small Flat Blade Screwdriver
- Panel Removal Tool

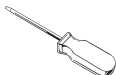
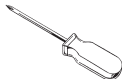

1-800-221-0932



www.metraonline.com

© COPYRIGHT 2001-2008 METRA ELECTRONICS CORPORATION



TABLE OF CONTENTS

***Dash Disassembly - All Vehicles*1**

***Final Assembly*2**

****Note:***

Refer also to the instructions included with the aftermarket radio.



KNOWLEDGE IS POWER

Enhance your installation and fabrication skills by enrolling in the most recognized and respected mobile electronics school in our industry.

Log onto www.installerinstitute.com or call 800-354-6782 for more information and take steps toward a better tomorrow.

ALL VEHICLES **DASH DISASSEMBLY**

Disconnect the negative battery terminal to prevent an accidental short circuit. Unclip the entire dash trim bezel and remove. Remove 9/32" fasteners from the right side of the factory radio module and (2) fasteners from the left side. Disconnect the wiring and remove the module. Refer also to instructions included with Metra Kit INST99-2020.

See Fig. A. Continue to final assembly.

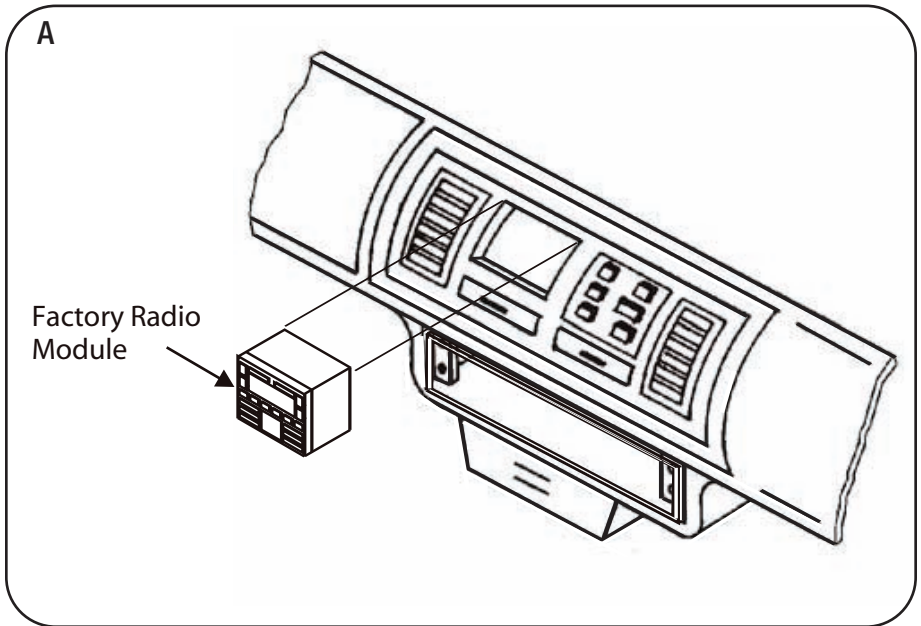

ALL VEHICLES
FINAL ASSEMBLY

- 1 Insert the Metra storage pocket in the radio cavity. *(See Fig. A)*

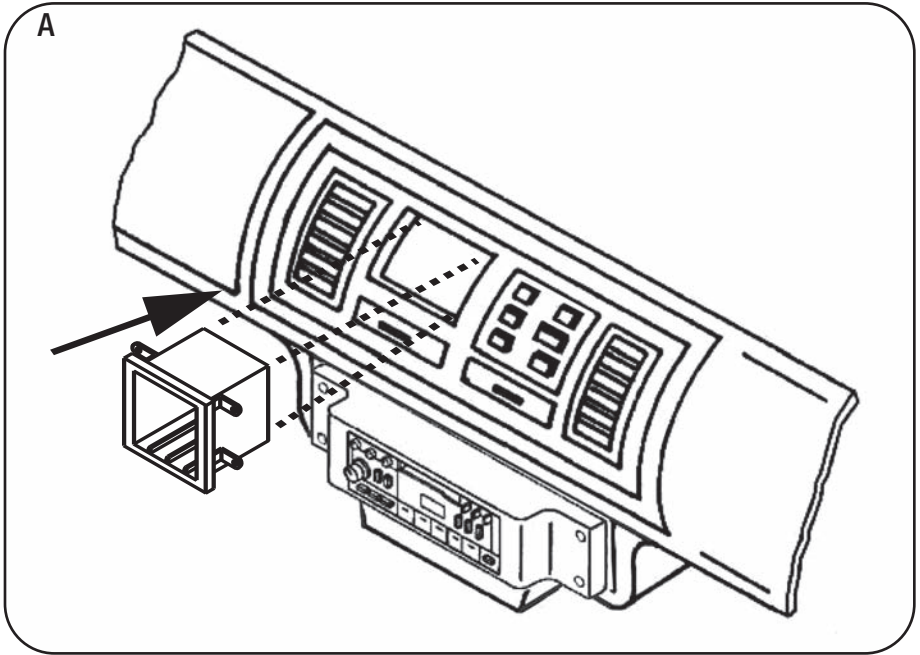

1-800-221-0932



www.metraonline.com

REV. 12/17/08 © COPYRIGHT 2001-2008 METRA ELECTRONICS CORPORATION INST99-2020