

IMPORTANT:
Read Before Using

IMPORTANT :
Lire avant usage

IMPORTANTE:
Leer antes de usar



Operating/Safety Instructions
Consignes de fonctionnement/sécurité
Instrucciones de funcionamiento y seguridad

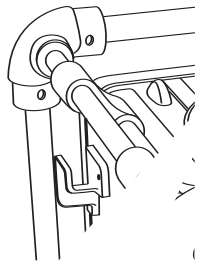

PB10

PB10-CD

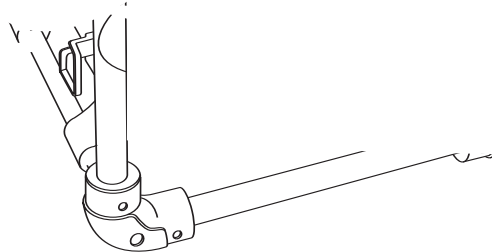

BOSCH

Consumer Information
Renseignements pour les consommateurs
Información para el consumidor

Toll Free Number: Appel gratuit : Número de teléfono gratuito:
1-877-BOSCH99 (1-877-267-2499) <http://www.boschtools.com>

WARNING

- TO PREVENT FIRE OR SHOCK HAZARD, DO NOT USE THIS PLUG WITH AN EXTENSION CORD, RECEPTACLE OR OTHER OUTLET UNLESS THE BLADES CAN BE FULLY INSERTED TO PREVENT BLADE EXPOSURE.

- TO PREVENT FIRE OR SHOCK HAZARD, DO NOT EXPOSE THE APPLIANCE TO RAIN OR MOISTURE.



The lightning flash with arrowhead symbol within an equilateral triangle is intended to alert the user to the presence of uninsulated “dangerous voltage” within the product’s enclosure that may be of sufficient magnitude to constitute a risk of electric to persons.

CAUTION:

RISK OF ELECTRIC SHOCK
DO NOT OPEN

CAUTION: TO REDUCE THE RISK OF ELECTRIC SHOCK, DO NOT REMOVE COVER (OR BACK). NO USER SERVICEABLE PARTS INSIDE. REFER SERVICING TO QUALIFIED SERVICE PERSONNEL.



The exclamation point within an equilateral triangle is intended to alert the user to the presence of important operating and maintenance (servicing) instructions in the literature accompanying the product.

IMPORTANT SAFETY INSTRUCTIONS

1. All the safety and operating instructions should be read before the product is operated.
2. The safety and operating instructions should be retained for future reference.
3. All warnings on the appliance and in the operating instructions should be adhered to.
4. All operating and use instructions should be followed.
5. Do not use this appliance near water.
6. Clean only with dry cloth.
7. Do not block any ventilation openings. Install in accordance with the manufacturer’s instruction.
8. Do not install near any heat sources such as radiators, heat registers, stoves, or other appliances (including amplifiers) that produce heat.
9. Do not defeat the safety purpose of the polarized or grounding-type plug. A polarized type plug has two blades with one wider than the other. A grounding type plug has two blades and a third grounding prong. The wide blade or the third prong is provided for your safety. If the provided plug does not fit into your outlet, consult an electrician for replacement of the obsolete outlet.
Caution: To prevent electrical shock, match wide blade plug to wide slot so as to be fully inserted.
10. Protect the power cord from being walked on or pinched particularly at plugs, convenience receptacles, and the point where they exit from the apparatus.
11. Only use attachments/accessories specified by the manufacturer.
12. Unplug this apparatus during lightning storms or when unused for long periods of time.
13. Refer all servicing to qualified service personal. Servicing is required when the apparatus has been damaged in any way, such as power-supply cord or plug is damaged, liquid has been spilled or objects have fallen into the apparatus, the apparatus has been exposed to rain or moisture, does not operate normally, or as been dropped.

This appliance shall not be exposed to dripping or splashing water and that no object filled with liquids such as vases shall be placed on the apparatus.

Table of Contents

	Page		Page
Safety	2-3	Aux Function	9
Important Safety Instructions	2	Audio Settings.....	9-10
Table of Contents	3	Releasing and Inserting the Battery Pack	10
FCC Information.....	3	Charging the Battery Pack.....	10
Battery/Charger	4	Important Charging Notes.....	11
Battery Care	4	To Power the Unit	11
Battery Disposal.....	4	Use of GFCI (Ground Fault Circuit Interruptor).....	11
Functional Description and Specifications	5	Use of GFCI	11
PB10 Controls.....	6	GFCI Testing Procedure.....	11
PB10-CD Controls	7	Use of 12V Outlet.....	12
LCD Displays.....	8	Changing Fuse.....	12
Setting the Clock.....	8	Trouble Shooting	12
Operating Instructions	8-12	Maintenance	13
Radio	8	Accessories	13
CD Player	9		

FCC Information

This device complies with Part 15 of the FCC Rules. Operation is subjected to the following two conditions:

- (1). This device may not cause harmful interference, and
- (2) This device must accept any interference received, including interference that may cause undesired operation.

CLASS 1 LASER PRODUCT

CLASS 1 LASER PRODUCT

CAUTION INVISIBLE LASER
RADIATION WHEN OPEN AND
INTERLOCKS DEFEATED.

AVOID EXPOSURE TO BEAM



This product contains a low power Laser Device.

Battery/Charger Rules

Before using battery charger, read all instructions and cautionary markings on (1) battery charger, (2) battery pack, and (3) product using battery.

Use only the charger which accompanied your product or direct replacement as listed in the catalog or this manual.

Do not disassemble radio unit or operate the radio unit if it has received a sharp blow, been dropped or otherwise damaged in any way. Replace damaged cord or plugs immediately. Incorrect reassembly or damage may result in electric shock or fire.

Do not recharge battery in damp or wet environment. Do not expose radio unit to rain or snow. If battery case is cracked or otherwise damaged, do not insert into charger. Battery short or fire may result.

Charge only Bosch approved rechargeable batteries. See Functional Description and Specifications. Other types of batteries may burst causing personal injury and damage.

Charge battery pack in temperatures above +40 degrees F (4 degrees C) and below +105 degrees F (41 degrees C). Store radio unit and battery pack in locations where

temperatures will not exceed 120 degrees F (49 degrees C). This is important to prevent serious damage to the battery cells.

Battery leakage may occur under extreme usage or temperature conditions. Avoid contact with skin and eyes. The battery liquid is caustic and could cause chemical burns to tissues. If liquid comes in contact with skin, wash quickly with soap and water, then with lemon juice or vinegar. If the liquid contacts your eyes, flush them with water for a minimum of 10 minutes and seek medical attention.

Place radio unit on flat non-flammable surfaces and away from flammable materials when re-charging battery pack. The charger and battery pack heat during charging. Carpeting and other heat insulating surfaces block proper air circulation which may cause overheating of the charger and battery pack. If smoke or melting of the case are observed unplug the charger immediately and do not use the battery pack or charger.

Use of an attachment not recommended or sold by Bosch may result in a risk of fire, electric shock or injury to persons.

Battery Care

⚠ WARNING When batteries are not in tool or charger, keep them away from metal objects. For example, to protect terminals from shorting DO NOT place batteries in a tool box or pocket with nails, screws, keys, etc. Fire or injury may result.

⚠ WARNING To prevent fire or injury when batteries are not in tool or charger, always place protective cap onto end of battery pack. Protective cap, guards against terminal shorting.

DO NOT PUT BATTERIES INTO FIRE OR EXPOSE TO HIGH HEAT. They may explode.

Battery Disposal

⚠ WARNING Do not attempt to disassemble the battery or remove any component projecting from the battery terminals. Fire or injury may result. Prior to disposal, protect exposed terminals with heavy insulating tape to prevent shorting.

Nickel-Cadmium Batteries

If equipped with a nickel-cadmium battery, the battery must be collected, recycled or disposed of in an environmentally sound manner.



"The EPA certified RBRC Battery Recycling Seal on the nickel-cadmium (Ni-Cd) battery indicates Robert Bosch Tool Corporation is voluntarily participating in an industry program to collect and recycle these batteries at the end of their useful life, when taken out

of service in the United States or Canada. The RBRC program provides a convenient alternative to placing used Ni-Cd batteries into the trash or the municipal waste stream, which may be illegal in your area.

Please call 1-800-8-BATTERY for information on Ni-Cd battery recycling and disposal bans/restrictions in your area, or return your batteries to a Skil/Bosch/Dremel Service Center for recycling. Robert Bosch Tool Corporation's involvement in this program is part of our commitment to preserving our environment and conserving our natural resources."

Nickel-Metal Hydride Batteries

If equipped with a nickel-metal hydride battery, the battery can be disposed of in a municipal solid waste stream.

Functional Description and Specifications

Jobsite Radio with 4-way GFCI outlet

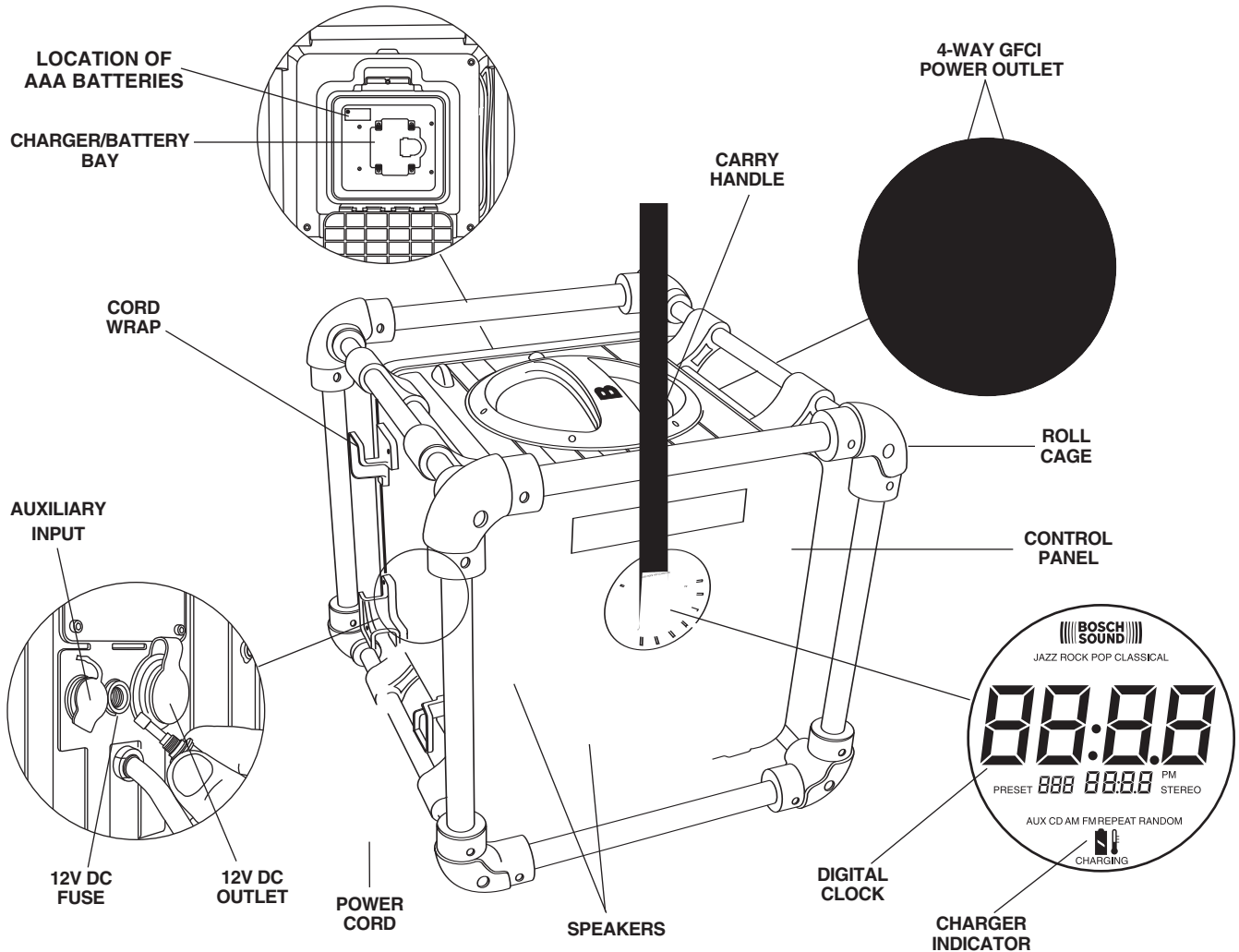

Model number

Voltage rating
Amperes
Compatible batteries

GFCI outlets

Voltage
Amperes

DC power outlets

Voltage
Amperes

Radio

CD

Memory

PB10

120 V ~ 60 Hz
12 A
BAT025-045

120 V ~ 60 Hz
10 A

12 V
1 Amp fuse
AM 520-1710KHZ
FM 87.9-107.9MHZ

N/A

AM 10-presets
FM 20-presets

PB10-CD

120 V ~ 60 Hz
12 A
BAT025-045

120 V ~ 60 Hz
10 A

12V
1 Amp fuse
AM 520-1710KHZ
FM 87.9-107.9MHZ

CD/CDR/MP3 Compatible

AM 10-presets
FM-20presets

PB10 Controls

1. **AUX** (Auxiliary)-Press to initiate the AUX mode to enjoy music from an auxiliary audio system.
2. **AM/FM** Button – Pressing switches between AM and FM when in Radio mode.
3. **STEREO** – Pressing switches between Stereo and Mono in FM Radio mode.
4. **EQ** Button – Pressing repeatedly selects between 5 preset equalizer settings, Rock, Pop, Classical, Jazz, and Normal.
5. **VOLUME CONTROL KNOB** – Turning increases or decreases the sound volume of the unit.
6. **TIME SET** Button – Pressing allows for the setting of time using Hour and Minute Buttons.
7. **MINUTE** Button – Pressing sets the minute, on the clock, after the Time Set Button is pressed.
8. **HOUR** Button – Pressing sets the hour, on the clock, after the Time Set Button is pressed.
9. **BOSCH SOUND** Button – Pressing turns Bosch's digitally enhanced sound on or off.
10. **POWER** Button – Pressing turns the unit on or off. (Power outlets are not controlled by power button. Outlets always have power if the unit is plugged in to a power source.)
11. **MEMORY**-Press to preset the AM/FM radio station.
12. **◀◀ PRESET**-Press to skip backward in presetting the radio stations in AM or FM.
13. **▶▶ PRESET**- Press to skip forward in presetting the radio stations in AM or FM.
14. **TUNER CONTROL KNOB** - Turning increases or decreases the radio tuner frequency.
15. **LCD Display**-Shows the various modes, clock time, and radio frequency.

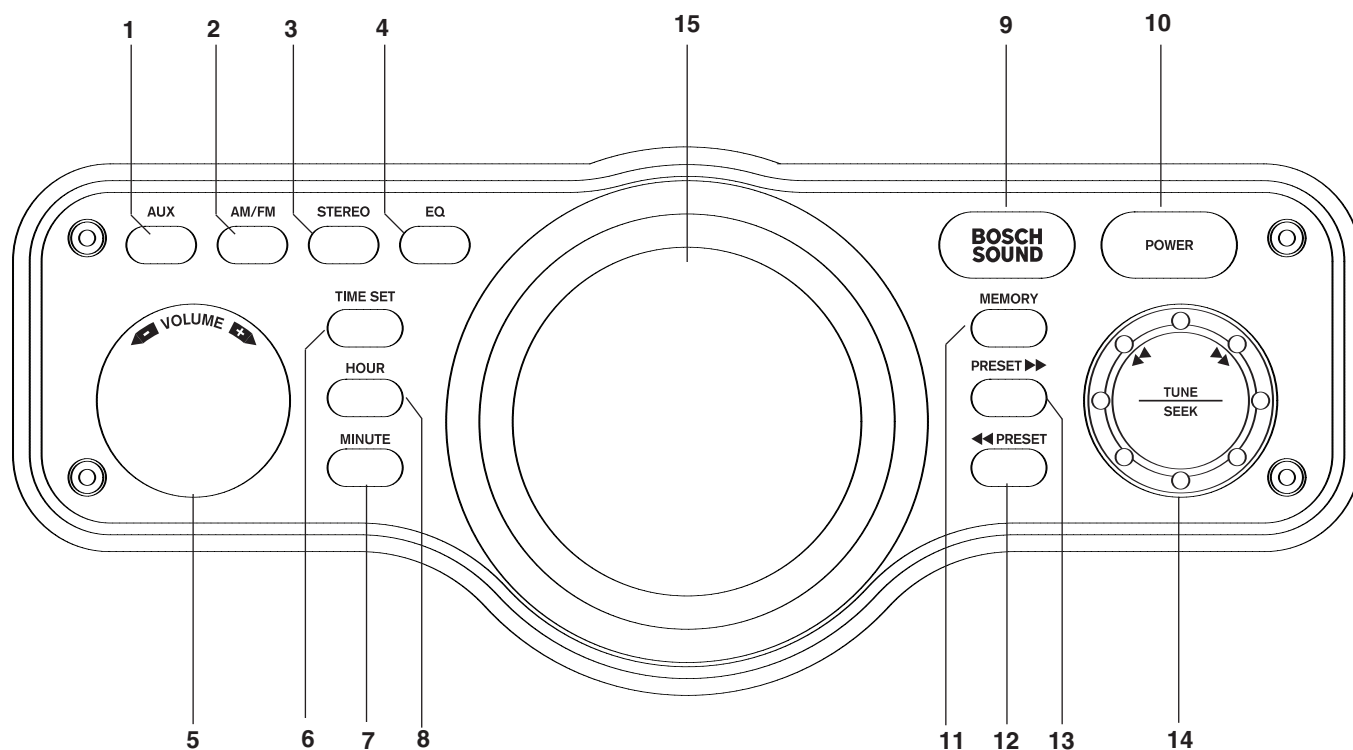

PB10 – CD Controls

1. **CD/AUX/RADIO** Button– Pressing repeatedly selects between the CD player, the Auxiliary Input, and the Radio.
2. **AM/FM** Button – Pressing switches between AM and FM when in Radio mode.
3. **EQ** Button – Pressing repeatedly selects between 5 preset equalizer settings, Rock, Pop, Classical, Jazz, and Normal.
4. **BOSCH SOUND** Button – Pressing turns Bosch's digitally enhanced sound on or off.
5. **TIME SET** Button – Pressing allows for the setting of time using Hour and Minute Buttons.
6. **HOUR** Button – Pressing sets the hour, on the clock, after the Time Set Button is pressed.
7. **MINUTE** button – Pressing sets the minute, on the clock, after the Time Set Button is pressed.
8. **POWER** Button – Pressing turns the unit on or off. (Power outlets are not controlled by power button. Outlets always have power if the unit is plugged in to a power source.)
9. **VOLUME CONTROL KNOB** – Turning increases or decreases the sound volume of the unit.
10. **■ STOP** Button – Press to stop the CD playing while in CD mode.
11. **▶/|| PLAY / PAUSE** Button – Pressing Plays a CD while in CD mode or Pauses a playing CD.
12. **▶▶ TRACK / PRESET / ◀◀ TRACK / PRESET** – Pressing skips/searchs for a track in CD mode or to select a Preset radio frequency in Radio mode.
13. **MEMORY** – Pressing sets radio tuner Presets, or sets CD tracks into memory.
14. **STEREO** – Pressing switches between Stereo and Mono in FM Radio mode.
15. **CD MODE** – Pressing selects Random or Repeat in CD mode.
16. **▲ OPEN/CLOSE** – Pressing opens or closes the CD tray for loading or removing the CD.
17. **TUNER CONTROL KNOB** - Turning increases or decreases the radio tuner frequency.
18. **LCD DISPLAY**-Shows the various modes, clock time, and radio frequency.
19. **CD TRAY**-Opens and closes to insert or remove a CD.

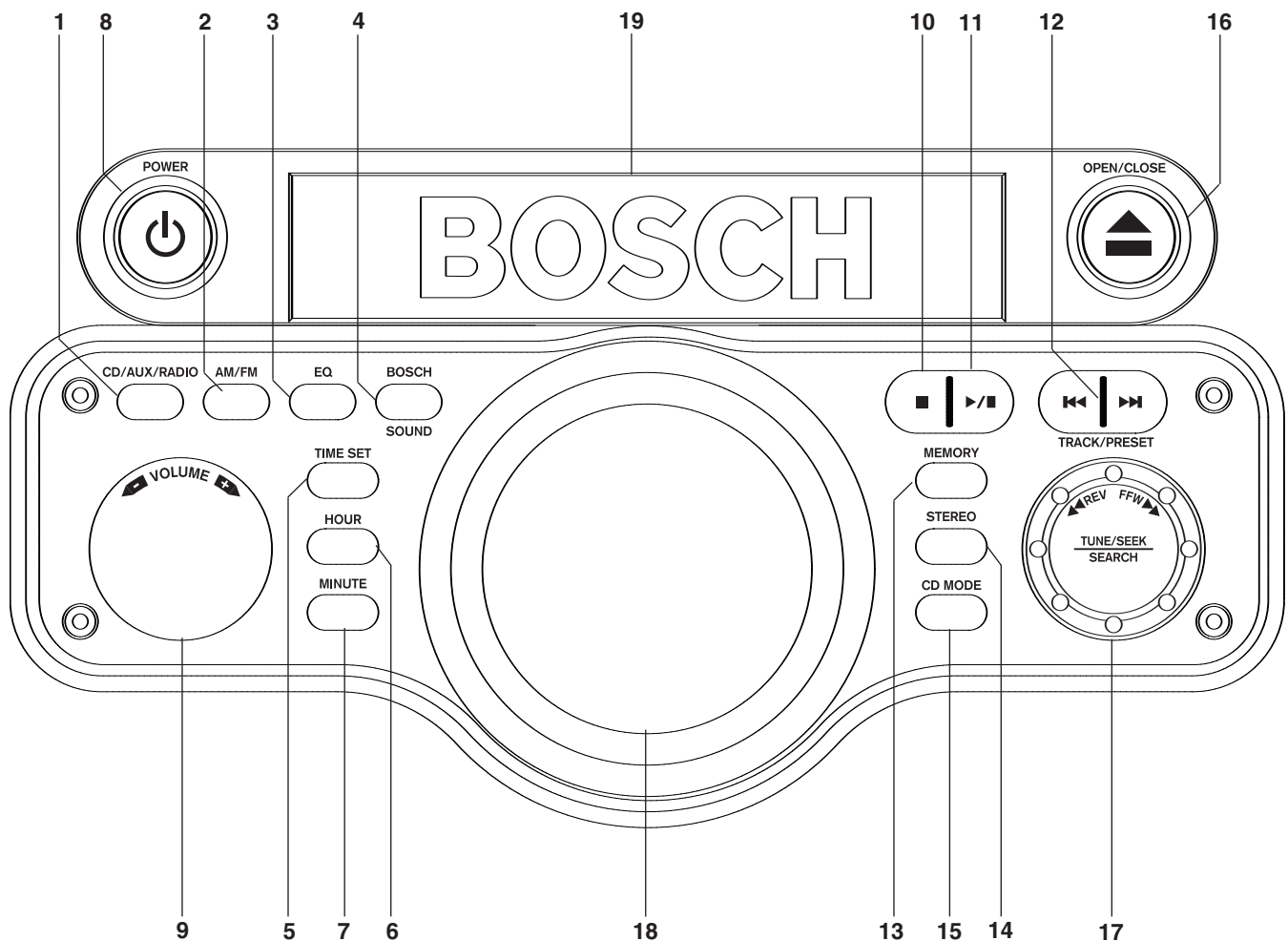

LCD Display

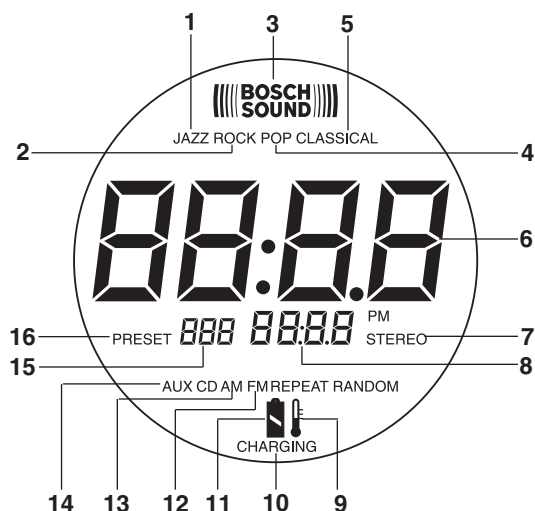

1. **JAZZ** -illuminates when Jazz is selected in EQ.
2. **ROCK**-illuminates when Rock is selected in EQ mode.
3. **BOSCH SOUND**-illuminates when you select BOSCH SOUND.

4. **POP**-illuminates when Pop is selected in EQ mode.
5. **CLASSICAL**-illuminates when Classical is selected in EQ mode.
6. **NUMERIC**-shows the clock time once it is set.
7. **STEREO**-illuminates when the radio station is broadcasting in Stereo channel.
8. **NUMERIC**-shows FM or AM frequency in tuner mode, or running time of a CD track.
9. **THERMOMETER** icon-indicates the battery is too hot or too cold and the charger is not charging.
10. **CHARGING**-flashes when the unit is charging the battery.
11. **BATTERY** icon-indicates that the battery is in the unit. The icon flashes when the battery is almost dead.
12. **FM**-indicates FM band in tuner mode.
13. **AM**-indicates AM band in tuner mode.
14. **AUX**-illuminates when you select AUX mode.
15. **NUMERIC**-shows the number of a preset station/CD track number selected.
16. **PRESET**-illuminates when you have a preset station selected and flashes while setting a station into memory.

Setting the Clock

When the AC plug or the battery pack is inserted, the unit defaults to standby mode and the LCD shows "12:00". Follow the steps below to set the correct local time.

1. Press **TIME SET** button on the unit once, and "hour", "minute" is activated and "00:00"flashes on the LCD display.
2. Press **HOUR** button repeatedly to choose the correct hour number, the hour number adds "1" every step.
3. Press **MINUTE** button repeatedly to choose the minute number, the minute number adds "1" every step.

4. Press and hold **MINUTE** button, and the minute time increases continuously till you select the correct minute time, and then release the button.
5. Press **TIME SET** once more to save it, and a "beep" sound is heard.

Note: 2 AAA batteries are supplied with the unit to keep time current when unit is not plugged in. Replace AAA batteries when unit no longer keeps proper time. (See changing AAA clock battery section.)

Operating Instructions

Audio Portion

Radio

TO SELECT BAND AND STATIONS

The tuner is operated in standard AM frequency from 520-1710MHz and in standard FM frequency from 87.5-107.9KHz. Follow the steps below to tune the station:

1. For model **PB10**: Press "**AM/FM**" button on the unit to select AM or FM band. For model **PB10-CD**: Press **Aux/CD/Radio** button repeatedly until radio is selected, then press **AM/FM** button if needed
2. Turn right (clockwise) **TUNE SEEK** ►► knob on the front panel 1/8th of a turn once, and the frequency increases by one every step

3. Turn right (clockwise) **TUNE SEEK** ►► knob and hold it for three seconds, the unit seeks forward automatically until a station with a strong signal is received.
4. Turn left (counterclockwise) **TUNE SEEK** ◀◀ knob on the front panel 1/8th of a turn once, and the frequency decreases by one every step.
5. Turn left (counterclockwise) **TUNE SEEK** ◀◀ knob and hold for three seconds, the unit seeks backwards automatically until a station with a strong signal is received.

Note: If there is no station received when it stops seeking, repeat the steps mentioned above to seek for the preferred stations.

TO PRESET STATIONS

Up to 20 stations for FM and 10 stations for AM can be preset. Please follow the steps below:

1. For model **PB10**: Press **AM/FM** on the unit to select AM or FM band. For model **PB10-CD** Press the **Aux/CD/Radio** button repeatedly until it is in the radio function, then press **AM/FM** button if needed.
2. Turn **TUNE SEEK** **◀/▶** knob to the right or left to choose the desired frequency.
3. Press **Memory** button on the unit once. PRESET and the station will flash on the display.
4. Press **▶/◀** to skip downward or upward to select the preset setting number.
5. Press **MEMORY** button once again to save it, and a beep sound is heard. PRESET and the station number "P 2" flashes on the LCD.

Note: Once 20 stations for FM or 10 stations for AM are set, the first preset station will be replaced if you continue to preset another one.

TO RETRIEVE THE PRESET STATIONS

1. Press **◀/▶** to search downward or upward for the desired preset stations to listen to.

TO EXIT THE PRESET STATIONS

1. Turn **TUNE SEEK** **◀/▶** knob to the right or left to exit the preset stations, and PRESET disappears from the LCD display.

CD Player (For model PB10-CD)

Playing a CD

1. If CD is not illuminated on the LCD, Press **CD/AUX/RADIO** button repeatedly until CD is illuminated.
2. Press the CD **OPEN/CLOSE** button to open the CD tray.
3. Carefully place CD on the center hub with the label side facing up. Gently press the CD down over the center hub.
4. Press the CD **OPEN/CLOSE** button again to close the CD tray.
5. Use the **TRACK** **▶▶** and **TRACK** **◀◀** to select the desired track.
6. Press **PLAY** **▶** to start playing the CD.

SETTING CD TRACKS INTO MEMORY

1. In CD mode, with a CD in the unit, with the CD not in play mode, press the PRESET button. PRESET 1 will illuminate on the LCD display.
2. Using the **TRACK** **▶▶** and **TRACK** **◀◀** select the track to be set to memory.
3. Press memory to set the track to memory in the specified location.
4. Repeat for up to 20 CD or MP3 tracks.
5. After programming the desired number of tracks, press play to start to play programmed tracks.

REPEATING A CD CONTINUOUSLY

1. In CD mode, with a CD in the unit, with the CD not in play mode, press the **CD MODE** button repeatedly until REPEAT highlights.
2. Press **PLAY** **▶** to start playing the CD.
3. When the CD reaches the end of the final track, it will start again at the beginning of the CD.

REPEATING A TRACK CONTINUOUSLY

1. In **CD MODE**, with a CD in the unit, press **PLAY** **▶** to start playing the CD. Press the **CD MODE** button repeatedly until REPEAT highlights.
2. When the CD reaches the end of the track, it will start again at the beginning of that track.

USING RANDOM TO PLAY TRACKS

1. In CD mode, with a CD in the unit, with the CD not in play mode, press the **CD MODE** button repeatedly until RANDOM highlights.
2. Press **PLAY** **▶** to start playing the CD.
3. Tracks will play in random order until all tracks have been played.

Aux Function

If you want to use an external audio source such as a portable CD player or MP3 player, the unit has a Auxiliary Port to accept these sources.

1. For model **PB10**, press **AUX** button to turn unit to auxiliary mode. AUX will illuminate on the LCD. For model **PB10-CD** Press the **CD/AUX/Radio** button repeatedly until AUX is illuminated on the LCD.
2. Open Aux port cover.
3. Insert plug from your cord into the AUX in jack on the left side of the unit.
4. Connect the other end of the cord into the headphone out or Aux out port on your Audio source.
5. Set the volume level of your external Audio source to the middle of the full volume. (50%)
6. Play the external audio source as you normally would.
7. Use the volume control on your Power Box to adjust the volume, not on the external audio source.

Audio Settings

Stereo/Mono

1. When a strong FM signal is received by the FM tuner, "STEREO" will illuminate on the LCD.
2. If a weak signal is received by the tuner, there will be audible static. To improve the sound of a weak station, press the **STEREO** button to turn off the stereo mode.

EQ

Your Power Box has 5 selectable preset equalizer settings depending on what you are listening too.

Pressing **EQ** repeatedly will select through the 5 EQ settings illuminating each setting on the LCD: JAZZ, ROCK, POP, CLASSICAL, (NORMAL not illuminated on LCD) Normal turns off the EQ.

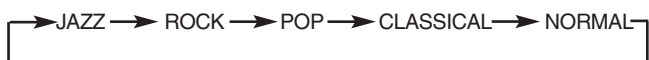

BOSCH SOUND

Your Power Box has a digital processor that allows you to listen to your music with superior sound quality.

1. The default setting for BOSCH SOUND is on.
2. To turn off BOSCH SOUND simply press the **BOSCH SOUND** button.

3. Press the button again to turn BOSCH SOUND back on.

TO ADJUST VOLUME

1. Turn right (clockwise) **VOLUME+** knob on the front panel 1/8th of a turn once to increase the sound level by 1 degree, and “VOL X” appears on the LCD display.

2. Turn right (clockwise) **VOLUME+** knob and hold it, the volume keeps increasing upward until you select it, and then release the knob. “VOL XX” goes up rapidly on the LCD display.

3. Turn left (counterclockwise) **VOLUME-** knob on the front panel 1/8th of a turn once to decrease the sound level by 1 degree, and “VOL X” appears on the LCD display.

4. Turn left (counterclockwise) **VOLUME-** knob and hold it, the volume keeps decreasing downward until you select it, and then release the knob. “VOL XX” goes down rapidly on the LCD display.

Releasing and Inserting Battery Pack

To release or insert the battery pack from radio unit, open the charger door by unlocking the latch. Before inserting battery pack, remove protective cap from battery pack. To insert battery, align battery and slide battery pack into tool until it locks into position. Do not force.

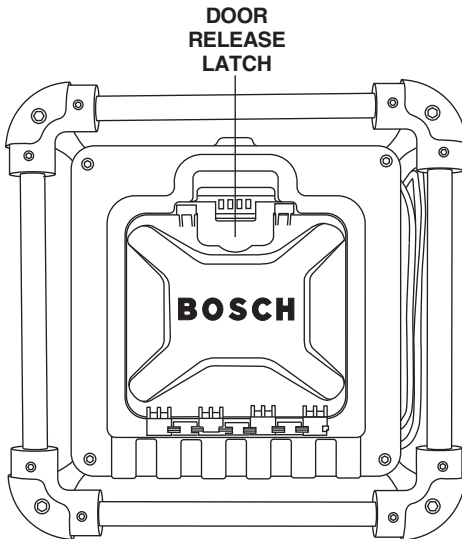

Charging Battery Pack

CHARGER OPERATION:

Insert battery and close door.

⚠ WARNING Charge only Bosch batteries BAT025-BAT045. Other batteries may burst causing injury and damage. Read additional safety information on underside of radio.

Open charger door by releasing latch. Plug the unit's power cord into your standard power outlet. Before inserting battery pack, remove protective cap, then insert battery pack into charger.

1. The LCD will display the battery “ICON” and “CHARGING” on the front of the unit. This indicates the battery pack is charging.

2. When “CHARGING” disappears, charging is complete

3. If when you begin the charging process of the battery pack, the “THERMOMETER ICON” is displayed on the LCD, this indicates the battery pack is too hot or too cold.

The battery pack will begin to charge once it reaches the proper temperature. The thermometer will disappear when it begins to charge.

4. The purpose of the charging icon on the LCD is to indicate that the battery pack is fast-charging. The charging icons will disappear in less time if the battery pack was not completely discharged.

5. When the battery pack is fully charged, the battery pack can be inserted into a tool, or used to power the radio instead of the power cord.

⚠ WARNING To prevent fire or injury when batteries are not in tool or charger, always place protective cap onto end of battery pack.

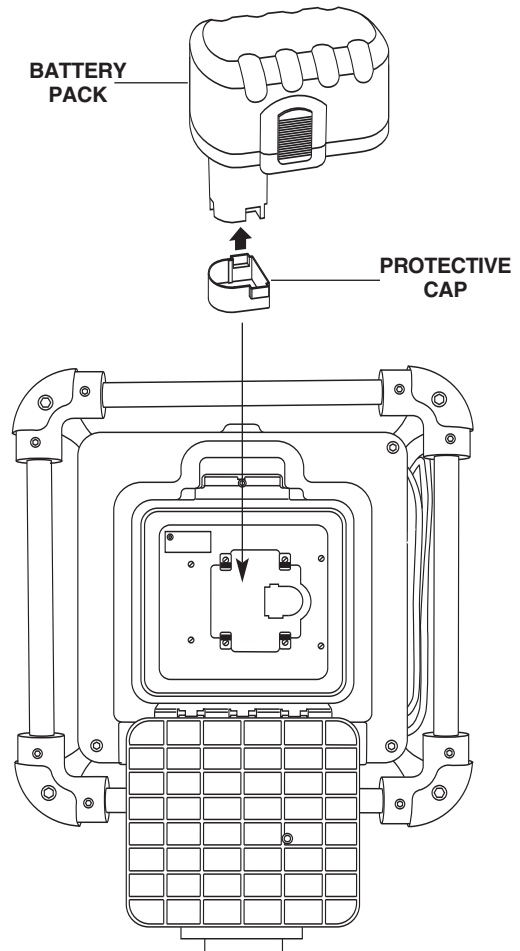

Important Charging Notes

1. The battery pack accepts only about 80% of its maximum capacity with its first few charge cycles. However, after the first few charge cycles, the battery will charge to full capacity.
2. The charger was designed to fast charge the battery only when the battery temperature is between 40°F (4°C) and 105°F (41°C).
3. A substantial drop in operating time per charge may mean that the battery pack is nearing the end of its life and should be replaced.
4. If you anticipate long periods (i.e. a month or more) of non-use of your tool, it is best to run your tool down until it is fully discharged before storing your battery pack. After a long period of storage, the capacity at first recharge will be lower. Normal capacity will be restored in two or three charge/discharge cycles. Remember to unplug charger during storage period.

5. If battery does not charge properly:
 - a. Check for voltage at outlet by plugging in some other electrical device.
 - b. Check to see if outlet is connected to a light switch which turns power "off" when lights are turned off.
 - c. Check battery pack terminals for dirt. Clean with cotton swab and alcohol if necessary.
 - d. If you still do not get proper charging, take or send radio unit and battery pack to your local Bosch Service Center.

See "Tools, Electric" in the Yellow Pages for names and addresses.

Note: Use of chargers or battery packs not sold by Bosch may void the warranty.

To power the unit

To Connect AC Power Plug

Plug the AC power cord of the unit into a standard AC power outlet/socket with AC 120V/60Hz, it will switch to AC once it is plugged in if it was running from a battery.

Note: The unit starts charging the battery automatically once the unit is running by AC power.

To Operate by the Battery

Bosch battery pack supplies DC power to the unit in radio and AUX modes when the unit is disconnected from AC power. 12V outlet power and 4 power outlets are not available until AC cord is plugged into AC.

USE OF GFCI (Ground fault circuit interruptor)

The GFCI helps protect you against hazardous electrical shock that may be caused if your body becomes a path through which electricity travels to ground. This could happen when you touch a power tool that is "live" through a faulty mechanism, dampness, worn insulation on the power cord, etc. A shock may happen even if you are only touching plumbing or another material that leads to ground. When using a GFCI device you may still feel a shock, but the GFCI is designed to cut off power quickly enough so that a normal healthy adult will not experience serious electrical injury.

⚠ WARNING GFCI's will NOT protect against:

1. Line-to-line shocks (of the type received when touching metal inserted in both straight slots of a receptacle).
2. Current overloads or line-to-neutral short-circuit. **THE FUSE OR CIRCUIT BREAKER AT THE DISTRIBUTION BOX OR PANEL MUST PROVIDE SUCH OVER-CURRENT PROTECTION!**

Use of the GFCI

With the Unit plugged into AC power, perform the following steps to use the GFCI protected power outlet:

1. Perform the GFCI testing procedure as specified on the unit and in this manual.

2. If the unit passed the GFCI testing, lift up the protective cover to expose the AC power outlets.
3. Plug into the outlet the desired AC appliance or power tool.
4. Once you are done using the AC outlets on the unit, insure that the protective covers properly close.

⚠ WARNING Do not use where water is likely to enter unit. This device will not guard against shock hazard from: 1. Defects or faults in the electrical supply to the interrupter. 2. Personal contact with both circuit conductors from the interrupter.

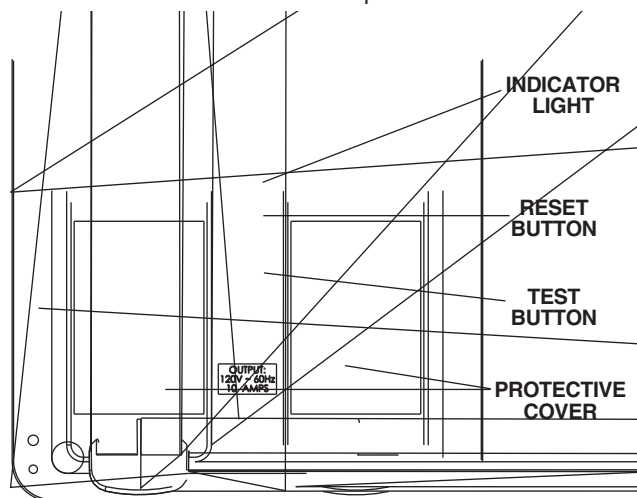

GFCI Testing Procedure

GFCI should be checked before each use.

1. Plug radio into power outlet. Indicator should turn red.
2. Press "TEST" button to energize. Indicator light to disappear.
3. Push "RESET" button again for use. Indicator light should turn red.
4. If unit fails the above procedure, do not use outlets and have unit serviced to correct malfunction.

Use of 12V Outlet

Note: Do not insert any device that pulls more than 1 Amp or else the fuse will open. **12V outlet will not operate from battery pack.**

1. Lift the rubber lid marked with 12V of the jack and insert the plug of the device or the appliance.
2. Close the lid as soon as you finish using the outlet to prevent any other things from entering the jack.
3. If no power is available then check fuse.

Changing fuse

1. Unscrew fuse cap in counterclockwise direction.
2. Replace fuse. Replace only with a **metric 5x20mm fast acting 1 Amp fuse**.
3. Tighten fuse cap assembly in clockwise direction.

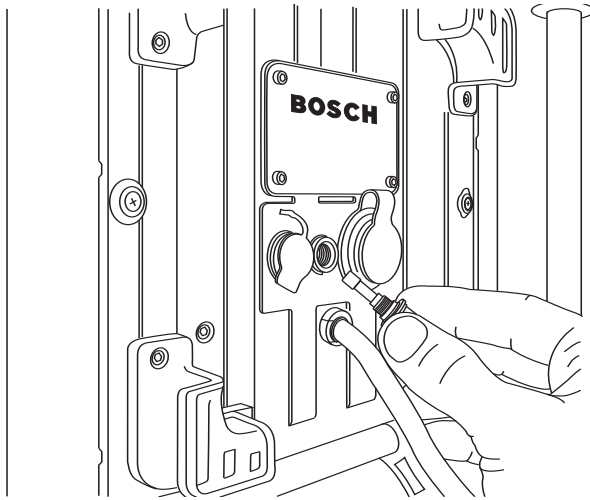

⚠ WARNING Do not bypass the fuse or use any other fuse except what is specified, as it may cause damage to the unit.

Changing Clock Batteries

1. Open battery bay door.
2. Remove AAA battery cover.
3. Remove old batteries and dispose of properly.
4. Insert new AAA batteries. Do not use mismatched batteries, use only new Alkaline batteries.

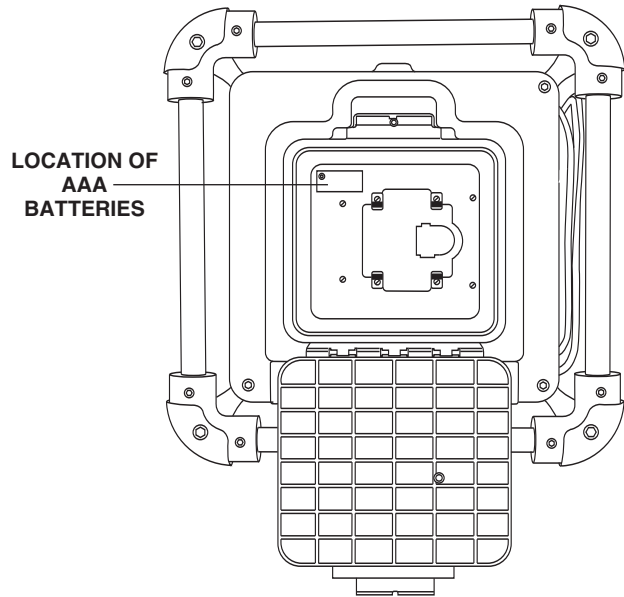

Trouble Shooting Guide

Problem	Checkpoint	Remedy
Audio Unit doesn't function.	<ol style="list-style-type: none"> 1. Is power cord properly connected ? 2. Is the Bosch battery pack installed or inserted properly? 3. Does the battery need charging? 	<ol style="list-style-type: none"> 1. Plug in AC power cord. 2. Make sure battery is completely inserted. 3. Plug in power cord and insert battery.
It is noisy or weak in radio receiving.	<ol style="list-style-type: none"> 1. Is there any facility interfering with the unit. 2. Is there any interference to the internal FM antenna? 	<ol style="list-style-type: none"> 1. Move unit to new location away from interference. 2. Turn the unit in different directions.
12V DC outlet doesn't function	<ol style="list-style-type: none"> 1. Is 1 amp fuse properly inserted? 2. Has the 1 amp fuse blown open? 	<ol style="list-style-type: none"> 1. Insert 1 amp fuse. 2. Replace fuse.
4-Way Power outlet does not function	<ol style="list-style-type: none"> 1. Is power cord properly connected? 2. Is red light illuminated on outlets? 	<ol style="list-style-type: none"> 1. Plug in AC power cord. 2. Press reset button. 3. Perform GFCI testing procedure.
Does unit suddenly fail to work	<ol style="list-style-type: none"> 1. Is power cord properly connected to unit? 2. Is the LCD displaying that there is power to the unit? 	<ol style="list-style-type: none"> 1. Plug in power to unit. 2. Software in unit needs to be reset. Remove battery from unit and unplug AC power cord, wait for 30 seconds and reconnect AC power cord.

Maintenance

Service

⚠ WARNING **NO USER SERVICEABLE PARTS INSIDE.** Preventive maintenance performed by unauthorized personnel may result in misplacing of internal wires and components which could cause serious hazard. We recommend that all tool service be performed by a Bosch Factory Service Center or Authorized Bosch Service Station. **SERVICEMEN:** Disconnect radio unit from power source before servicing.

Service must be performed only by qualified repair personnel. Service or maintenance performed by unqualified personnel may result in a risk of injury.

When servicing, use only identical replacement parts. Follow instructions in the Maintenance section of this manual. Use of unauthorized parts or failure to follow Maintenance Instructions may create a risk of shock or injury.

BATTERIES

Be alert for battery packs that are nearing their end of life. If you notice decreased tool performance or significantly shorter running time between charges then it is time to replace the battery pack. Failure to do so can cause the tool to operate improperly or damage the charger.

Long term battery storage should be in the discharged state. Battery packs last longer and re-charge better when they are stored discharged. Remember to fully re-charge battery packs before using after prolonged storage.

Cleaning

⚠ WARNING To avoid accidents, always disconnect the radio unit from the power supply before cleaning.

CD LENS

Take care to avoid getting dust or moisture on the lens CD laser. Never touch the CD laser lens. Use only commercially available CD lens cleaners or take unit to a Bosch service center to clean the lens.

COMPACT DISC CARE

To remove a disc from its storage case, press down on the center of the case and lift the disc out, holding it carefully by the edges.

Fingerprints and dust should be carefully wiped off the disc's recorded surface with a soft cloth. Wipe in a straight line from the inside to the outside of the disc.

Clean the disc periodically with a soft, lint-free dry cloth. Never use detergents or abrasive cleaners to clean the disc. If necessary, use a CD cleaning kit.

Avoid storing discs in locations where there is direct exposure to sunlight and high levels of humidity.

THE MAIN UNIT

Never insert a dirty/scraped disc into unit or allow dirt or sand to enter the unit.

Do not remove the unit suddenly from a very cold area into a warm area. Otherwise moisture condensation may form on the optical lens, preventing proper operation.

Do not leave the unit exposed to direct light sunlight for long periods of time, it may deform or discolor the cabinet and may also cause malfunctioning.

Wipe the unit with a soft cloth. Remove stubborn dirt using a damp cloth that was dipped in soapy water, then wipe dry.

If you intend to use a chemical cleaning cloth, read its instruction first.

Do not use alcohol or paint thinners.

⚠ CAUTION **Certain cleaning agents and solvents damage plastic parts.** Some of these are: gasoline, carbon tetrachloride, chlorinated cleaning solvents, ammonia and household detergents that contain ammonia.

Accessories

⚠ WARNING If an extension cord is necessary, a cord with adequate size conductors that is capable of carrying the current necessary for your tool must be used. This will prevent excessive voltage drop, loss of power or overheating. Grounded tools must use 3-wire extension cords that have 3-prong plugs and receptacles.

NOTE: The smaller the gauge number, the heavier the cord.

**RECOMMENDED SIZES OF EXTENSION CORDS
120 VOLT ALTERNATING CURRENT TOOLS**

Tool's Ampere Rating	Cord Size in A.W.G.				Wire Sizes in mm ²			
	Cord Length in Feet				Cord Length in Meters			
	25	50	100	150	15	30	60	120
3-6	18	16	16	14	.75	.75	1.5	2.5
6-8	18	16	14	12	.75	1.0	2.5	4.0
8-10	18	16	14	12	.75	1.0	2.5	4.0
10-12	16	16	14	12	1.0	2.5	4.0	—
12-16	14	12	—	—	—	—	—	—

LIMITED WARRANTY OF BOSCH PORTABLE AND BENCHTOP POWER TOOLS

Robert Bosch Tool Corporation ("Seller") warrants to the original purchaser only, that all BOSCH portable and benchtop power tools will be free from defects in material or workmanship for a period of one year from date of purchase. SELLER'S SOLE OBLIGATION AND YOUR EXCLUSIVE REMEDY under this Limited Warranty and, to the extent permitted by law, any warranty or condition implied by law, shall be the repair or replacement of parts, without charge, which are defective in material or workmanship and which have not been misused, carelessly handled, or misrepaired by persons other than Seller or Authorized Service Station. To make a claim under this Limited Warranty, you must return the complete portable or benchtop power tool product, transportation prepaid, to any BOSCH Factory Service Center or Authorized Service Station. For Authorized BOSCH Power Tool Service Stations, please refer to your phone directory.

THIS LIMITED WARRANTY DOES NOT APPLY TO ACCESSORY ITEMS SUCH AS CIRCULAR SAW BLADES, DRILL BITS, ROUTER BITS, JIGSAW BLADES, SANDING BELTS, GRINDING WHEELS AND OTHER RELATED ITEMS.

ANY IMPLIED WARRANTIES SHALL BE LIMITED IN DURATION TO ONE YEAR FROM DATE OF PURCHASE. SOME STATES IN THE U.S., SOME CANADIAN PROVINCES DO NOT ALLOW LIMITATIONS ON HOW LONG AN IMPLIED WARRANTY LASTS, SO THE ABOVE LIMITATION MAY NOT APPLY TO YOU.

IN NO EVENT SHALL SELLER BE LIABLE FOR ANY INCIDENTAL OR CONSEQUENTIAL DAMAGES (INCLUDING BUT NOT LIMITED TO LIABILITY FOR LOSS OF PROFITS) ARISING FROM THE SALE OR USE OF THIS PRODUCT. SOME STATES IN THE U.S. AND SOME CANADIAN PROVINCES DO NOT ALLOW THE EXCLUSION OR LIMITATION OF INCIDENTAL OR CONSEQUENTIAL DAMAGES, SO THE ABOVE LIMITATION OR EXCLUSION MAY NOT APPLY TO YOU.

THIS LIMITED WARRANTY GIVES YOU SPECIFIC LEGAL RIGHTS, AND YOU MAY ALSO HAVE OTHER RIGHTS WHICH VARY FROM STATE TO STATE IN THE U.S., PROVINCE TO PROVINCE IN CANADA AND FROM COUNTRY TO COUNTRY.

THIS LIMITED WARRANTY APPLIES ONLY TO PORTABLE AND BENCHTOP ELECTRIC TOOLS SOLD WITHIN THE UNITED STATES OF AMERICA, CANADA AND THE COMMONWEALTH OF PUERTO RICO. FOR WARRANTY COVERAGE WITHIN OTHER COUNTRIES, CONTACT YOUR LOCAL BOSCH DEALER OR IMPORTER.

GARANTIE LIMITÉE DES OUTILS ÉLECTRIQUES PORTATIFS ET D'ÉTABLI BOSCH

Robert Bosch Tool Corporation (le « vendeur ») garantit à l'acheteur initial seulement que tous les outils électriques portatifs et d'établi BOSCH seront exempts de vices de matériaux ou d'exécution pendant une période d'un an depuis la date d'achat. LA SEULE OBLIGATION DU VENDEUR ET LE SEUL RECOURS DE L'ACHETEUR sous la présente garantie limitée, et en autant que la loi le permette sous toute garantie ou condition implicite qui en découlerait, sera l'obligation de remplacer ou réparer gratuitement les pièces défectueuses matériellement ou comme fabrication, pourvu que lesdites défectuosités ne soient pas attribuables à un usage abusif ou à quelque réparation bricolée par quelqu'un d'autre que le vendeur ou le personnel d'une station-service agréée. Pour présenter une réclamation en vertu de cette garantie limitée, vous devez renvoyer l'outil électrique portatif ou d'établi complet, port payé, à tout centre de service agréé ou centre de service usine BOSCH. Veuillez consulter votre annuaire téléphonique pour les adresses.

LA PRÉSENTE GARANTIE NE S'APPLIQUE PAS AUX ACCESSOIRES TELS QUE LAMES DE SCIES CIRCULAIRES, MÈCHES DE PERCEUSES, FERS DE TOUPIES, LAMES DE SCIES SAUTEUSES, COURROIES DE PONÇAGE, MEULES ET AUTRES ARTICLES DU GENRE.

TOUTE GARANTIE IMPLICITE SERA LIMITÉE COMME DURÉE À UN AN À COMPTER DE LA DATE D'ACHAT. CERTAINS ÉTATS AMÉRICAINS, CERTAINES PROVINCES CANADIENNES N'ADMETTANT PAS LE PRINCIPE DE LA LIMITATION DE LA DURÉE DES GARANTIES IMPLICITES, IL EST POSSIBLE QUE LES LIMITATIONS CI-DESSUS NE S'APPLIQUENT PAS À VOTRE CAS.

EN AUCUN CAS LE VENDEUR NE SAURAIT ÊTRE TENU POUR RESPONSABLE DES INCIDENTS OU DOMMAGES INDIRECTS (INCLUANT, MAIS NE SE LIMITANT PAS AUX PERTES DE PROFITS) CONSÉQUENTS À LA VENTE OU L'USAGE DE CE PRODUIT. CERTAINS ÉTATS AMÉRICAINS ET CERTAINES PROVINCES CANADIENNES N'ADMETTANT PAS LE PRINCIPE DE LA LIMITATION NI L'EXCLUSION DES DOMMAGES INDIRECTS ET CONSÉQUENTIELS, IL EST POSSIBLE QUE LES LIMITATIONS OU EXCLUSIONS CI-DESSUS NE S'APPLIQUENT PAS À VOTRE CAS.

LA PRÉSENTE GARANTIE VOUS ACCORDE DES DROITS BIEN DÉTERMINÉS, Y COMPRIS POSSIBLEMENT CERTAINS DROITS VARIABLES DANS LES DIFFÉRENTS ÉTATS AMÉRICAINS, PROVINCES CANADIENNE ET DE PAYS À PAYS.

CETTE GARANTIE LIMITÉE NE S'APPLIQUE QU'AUX OUTILS ÉLECTRIQUES PORTATIFS ET D'ÉTABLI VENDUS AUX ÉTATS-UNIS D'AMÉRIQUE, AU CANADA ET AU COMMONWEALTH DE PORTO RICO. POUR COUVERTURE DE GARANTIE DANS LES AUTRES PAYS, CONTACTEZ VOTRE IMPORTATEUR OU REVENDEUR BOSCH LOCAL.

GARANTIA LIMITADA PARA HERRAMIENTAS MECANICAS PORTATILES Y PARA TABLERO DE BANCO BOSCH

Robert Bosch Tool Corporation ("el Vendedor") garantiza, únicamente al comprador original, que todas las herramientas mecánicas portátiles y para tablero de banco BOSCH estarán libres de defectos de material o de fabricación durante un período de un año a partir de la fecha de compra. LA UNICA OBLIGACION DEL VENDEDOR Y EL RECURSO EXCLUSIVO QUE USTED TIENE bajo esta Garantía Limitada y, hasta donde la ley lo permita, bajo cualquier garantía o condición implícita por ley, consistirá en la reparación o sustitución sin costo de las piezas que presenten defectos de material o de fabricación y que no hayan sido utilizadas incorrectamente, manejadas descuidadamente o reparadas incorrectamente por personas que no sean el Vendedor o una Estación de servicio autorizada. Para efectuar una reclamación bajo esta Garantía Limitada, usted debe devolver el producto, que consiste en la herramienta mecánica portátil o para tablero de banco completa, con el transporte pagado, a cualquier Centro de servicio de fábrica o Estación de servicio autorizada BOSCH. Para Estaciones de servicio autorizadas de herramientas mecánicas BOSCH, por favor, consulte el directorio telefónico.

ESTA GARANTIA LIMITADA NO SE APLICA A ARTICULOS ACCESORIOS TALES COMO HOJAS PARA SIERRAS CIRCULARES, BROCAS PARA TALADROS, BROCAS PARA FRESADORAS, HOJAS PARA SIERRAS DE VAIVEN, CORREAS PARA LIJAR, RUEDAS DE AMOLAR Y OTROS ARTICULOS RELACIONADOS.

TODAS LAS GARANTIAS IMPLICITAS TENDRAN UNA DURACION LIMITADA A UN AÑO A PARTIR DE LA FECHA DE COMPRA. ALGUNOS ESTADOS DE LOS EE.UU., ALGUNAS PROVINCIAS CANADIENSES NO PERMITEN LIMITACIONES EN CUANTO A LA DURACION DE UNA GARANTIA IMPLICITA, POR LO QUE ES POSIBLE QUE LA LIMITACION ANTERIOR NO SEA APLICABLE EN EL CASO DE USTED.

EL VENDEDOR NO SERA RESPONSABLE EN NINGUN CASO DE NINGUN DAÑO INCIDENTAL O EMERGENTE (INCLUYENDO PERO NO LIMITADO A RESPONSABILIDAD POR PERDIDA DE BENEFICIOS) QUE SE PRODUZCA COMO CONSECUENCIA DE LA VENTA O UTILIZACION DE ESTE PRODUCTO. ALGUNOS ESTADOS DE LOS EE.UU. Y ALGUNAS PROVINCIAS CANADIENSES NO PERMITEN LA EXCLUSION O LIMITACION DE LOS DAÑOS INCIDENTALES O EMERGENTES, POR LO QUE ES POSIBLE QUE LA LIMITACION O EXCLUSION ANTERIOR NO SEA APLICABLE EN EL CASO DE USTED.

ESTA GARANTIA LIMITADA LE CONFIERE A USTED DERECHOS LEGALES ESPECIFICOS Y ES POSIBLE QUE USTED TAMBIEN TENGA OTROS DERECHOS QUE VARIAN DE ESTADO A ESTADO EN LOS EE.UU., DE PROVINCIA A PROVINCIA EN CANADA Y DE UN PAIS A OTRO.

ESTA GARANTIA LIMITADA SE APLICA SOLAMENTE A HERRAMIENTAS ELECTRICAS PORTATILES Y PARA TABLERO DE BANCO VENDIDAS EN LOS ESTADOS UNIDOS DE AMERICA, CANADA Y EL ESTADO LIBRE ASOCIADO DE PUERTO RICO. PARA COBERTURA DE GARANTIA EN OTROS PAISES, PONGASE EN CONTACTO CON SU DISTRIBUIDOR O IMPORTADOR LOCAL DE BOSCH.

© Robert Bosch Tool Corporation 1800 W. Central Road Mt. Prospect, IL 60056 -2230

Exportado por: Robert Bosch Tool Corporation Mt. Prospect, IL 60056 -2230, E.U.A.

Importado en México por: Robert Bosch, S.A. de C.V., Calle Robert Bosch No. 405, Zona Industrial,

Toluca, Edo. de México, C.P. 50070, Tel. (722) 2792300

2610920597 04/04

Printed in China