



Master Series Gas Xpress Grill

Item: _____
 Quantity: _____
 Project: _____
 Approval: _____
 Date: _____

Master Series Gas Xpress Grill

Models:

- | | | | |
|----------------------------------|------------------------------------|------------------------------------|-----------------------------------|
| <input type="checkbox"/> XG24* | <input type="checkbox"/> XG24-1L | <input type="checkbox"/> XG24-1R | <input type="checkbox"/> XG24-F |
| <input type="checkbox"/> XG24CE* | <input type="checkbox"/> XG24CE-1L | <input type="checkbox"/> XG24CE-1R | <input type="checkbox"/> XG24CE-F |



Model XG24

Standard Features:

- Stainless steel front, top & sides
- Swivel casters (4) w/ front brakes
- 33,000 BTU/hr. heat input for each 12" section of griddle
- 3/4" NPT bottom gas connection
- Built in pressure regulator (one per 12" section of griddle) and gas shut-off valve
- 3/4" (19mm) thick, Carbon steel griddle plate, machine ground, highly polished
- Multi-colored LED indicator lights to identify operational mode
- Towel bar with bun pan lip
- Stainless steel dual side grease collectors
- Automatic lifting and lowering of top heaters
- Separate programmable controller for each 12" section

- Die cast aluminum electric top heating elements rated 208V/220V/240V, single or 3-phase for XG24 models and 380V/400V/415V, 3- phase for XG24CE models
- One year limited parts and labor (USA & Canada)

Optional Features:

- Quick disconnect gas hose 3' (914mm) length
- Flared grease containers: (2) 1.5 gal., (5.68 L), with removable tool holders. NOTE: Increases overall width of grill to 35" (889mm), (tools not included).



Specification:

Two sided cooking device with gas-fired griddle and two independently controlled 11.5" (292mm) wide electric top heaters. Each 12" inches of lower griddle plate to have 33,000 BTU/hr of heat input natural or propane gas. Burner to be rectangular shaped 16 GA stainless steel with laser cut port pattern. Griddle plate to be 3/4" (19mm) thick Carbon steel, machine ground and highly polished. Automatic lighting, temperature, time & gap control monitored via custom programmable controllers, one per foot of griddle. Gas pressure regulator and manual shut-off valve to be provided as standard. Electric top heaters to be provided with replaceable quick release Teflon sheets. Top heaters to have gapping adjustment in 0.010" increments. Available with two (XG24), one (XG24-1L/R) or zero (XG36-F) top platen. Grill available in 208V/220V/240V three phase and 380V/400V/415V three phase for export



* ENERGY STAR® qualified models



NOTE: Grills supplied with casters must be installed with an approved restraining device.

Garland Commercial Ranges Ltd.
 1177 Kamato Road,
 Mississauga, Ontario
 L4W 1X4 CANADA

General Inquires 1-905-624-0260
 USA Sales, Parts and Service 1-800-424-2411
 Canadian Sales 1-888-442-7526
 Canada or USA Parts/Service 1-800-427-6668



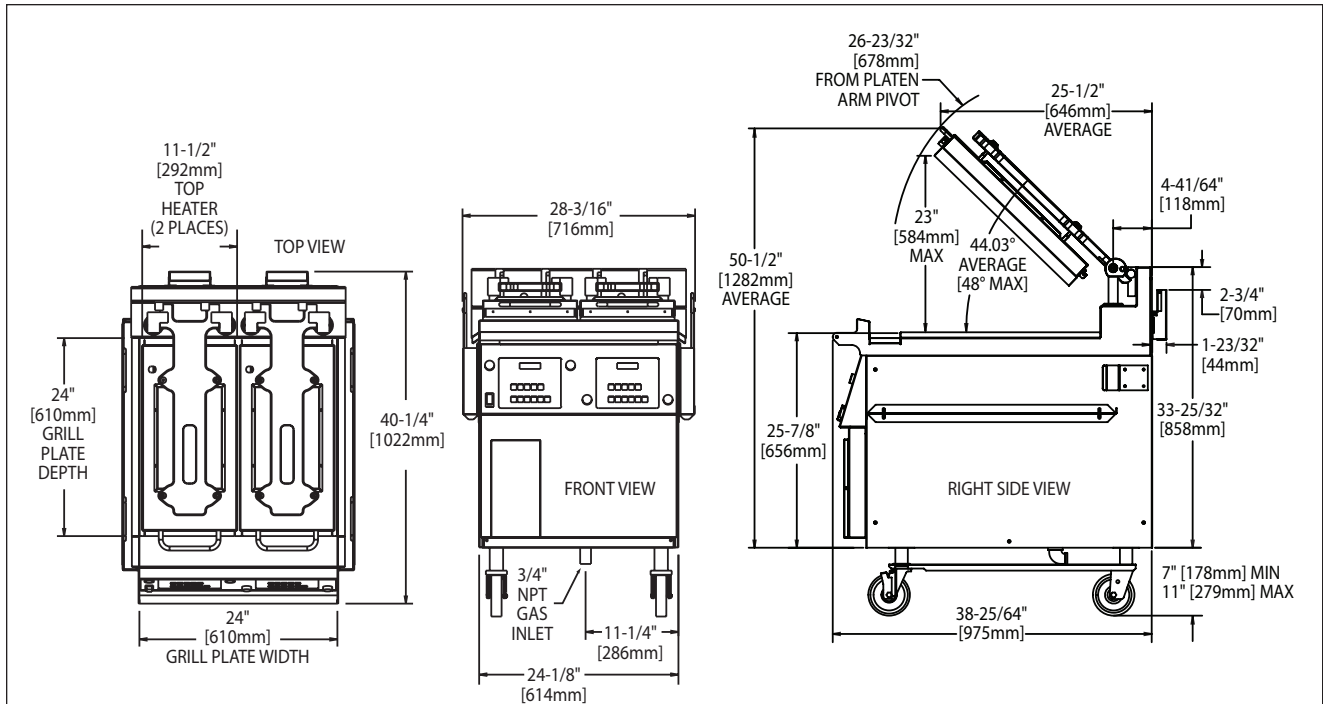

Model	Total kW Load	Loading kW/Phase			Nominal Amps Per Line											
		208/220/240V 3ph			208V			220V			240V					
		X-Y	X-Z	Y-Z	1-Ph	3-Phase Delta			1-Ph	3-Phase Delta			1-Ph	3-Phase Delta		
		L1-L2	X	Y	Z	L1-L2	X	Y	Z	L1-L2	X	Y	Z	L1-L2	X	Y
XG24	8.66	2.66	3.33	2.66	41.63	24.90	22.14	24.90	39.36	23.50	20.94	23.50	36.08	21.61	19.19	21.61
XG24-1 L/R	4.33	1.33	1.65	1.33	20.82	12.14	11.07	12.14	19.68	11.75	10.47	11.75	18.04	10.80	9.59	10.80
XG24-F	0.66	-	0.66	-	3.17	2.74	-	2.74	3.00	2.59	-	2.59	2.75	2.38	-	2.38

Model	Total kW Load	Loading kW Per Phase				Nominal Amps Per Line											
		380/400/415V				380V			400V			415V					
		L1/N	L1/L2	L1/L3	L2/L3	L1/N	L1	L2	L3	L1/N	L1	L2	L3	L1/N	L1	L2	L3
XG24CE	8.74	0.74	2.66	2.66	2.66	3.36	15.90	12.46	12.46	3.22	13.40	11.55	11.55	3.08	12.10	11.11	11.11
XG24CE-1 L/R	4.56	0.56	1.33	1.33	1.33	2.54	7.33	6.02	6.02	4.30	19.80	17.32	17.32	4.12	18.75	16.70	16.70
XG24CE-F	0.38	0.38	0.00	0.00	0.00	1.72	1.00	0.00	0.00	1.58	0.95	0.00	0.00	0.91	12.10	11.11	11.11

Clearances				Gas Pressure				Total Input	
Entry		Installation		Supply (min.)		Operating			
Crated	Uncrated	Sides	Rear	NAT	PRO	NAT	PRO	BTU/Hr	kW
47-1/2" (1207mm)	32" (813mm)	6" (152mm)	3" (76mm)	7.0" WC	11.0" WC	3.5" WC	3.5" WC	66,000	19.4

Form# XG24 (07/26/11)