

Industrial Ringdown/Autodialer Telephone SCR Series

Installation & Operation

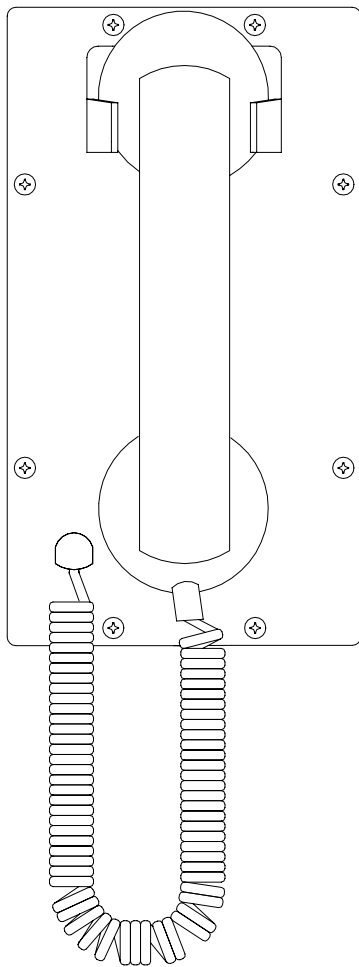

SCR 11

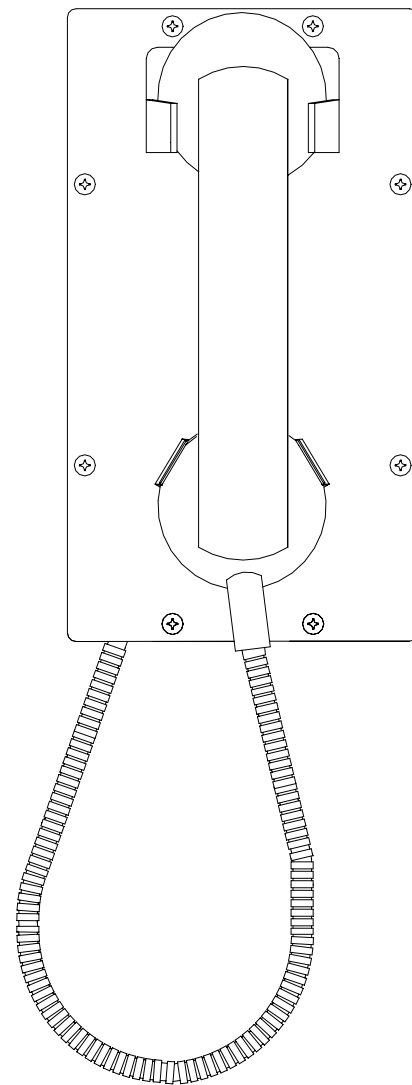

SCR 41

Table of Contents

Package Contents2
 SCR Models2
 Options Available.....2
 Overview.....3
 Features3
 Installing the SCR.....6
 Operating the SCR6
 Field Repairs7
 Engineering Specifications8
 Accessories9
 Replacement Parts9
 Warranty10
 Disclaimer10
 Warning10
 Service Telephone Number.....10
 Feedback.....10
 Guardian Product Return.....11

Table of Figures

Figure 1 - Features4
 Figure 2 - Overall Dimensions4
 Figure 3 - Installation SCR-115
 Figure 4 - Installation SCR-415

Package Contents

- (1) SCR Telephone
- (1) Installation & Operation Manual

SCR Models

Part No.	Model	Description
P6961	SCR-11	Heavy Duty 6' Curly Cord
P6970	SCR-41	Armored Handset Cord & Handset Retainer Clip

Options Available		
20' Heavy Duty Curly Cord	(20C)	(Not available with SCR-41)
Noise Canceling Microphone	(NC)	

Overview

SCR Industrial Ringdown/Autodialer Telephone

The SCR is a rugged industrial telephone designed to provide safe, reliable, point to point communication in harsh environments such as refineries, mills, plants, warehouses or areas with high humidity.

The SCR Telephone may be supplied with an optional Auto Dialer or dialing may be programmed through a PABX. If an Auto Dialer is ordered with the SCR refer to the manual for the Auto Dialer for instructions on programming and for compliances.

Features

Enclosure

- 16 Gauge steel, zinc dichromate plated and powder coated

Epoxy Resin Coating

- encapsulates all parts on main circuit board
- resistant to corrosive agents (eg. H₂S, SO₂, and NH₃), and high humidity

Magnetic Reed Hook Switch

- no moving parts

Surge Arrestor

- Protects the user in the event of a high voltage spike on the telephone line

Fuse

- Prevents damage to the electronic circuits in the event of a high voltage spike on the telephone line

Noise Reducing Microphone

- allows a high level of intelligibility in locations with high background noise.

Receiver Volume Control

- Switch in handset provides 13.5dB of range

Heavy Duty Handset Cord (SCR 11)

- withstands abusive use

Armored Handset Cord (SCR 41)

- vandal resistant

Hearing-Aid Compatibility

- compatible with inductively coupled hearing-aid devices

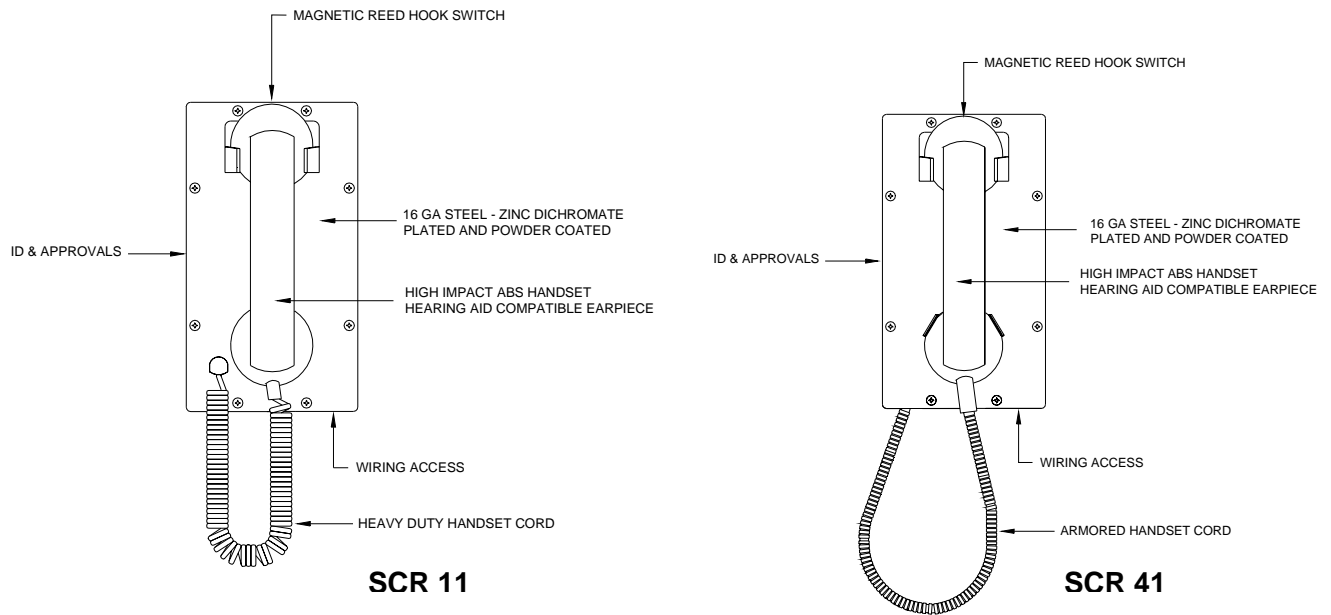

Figure 1 - Features

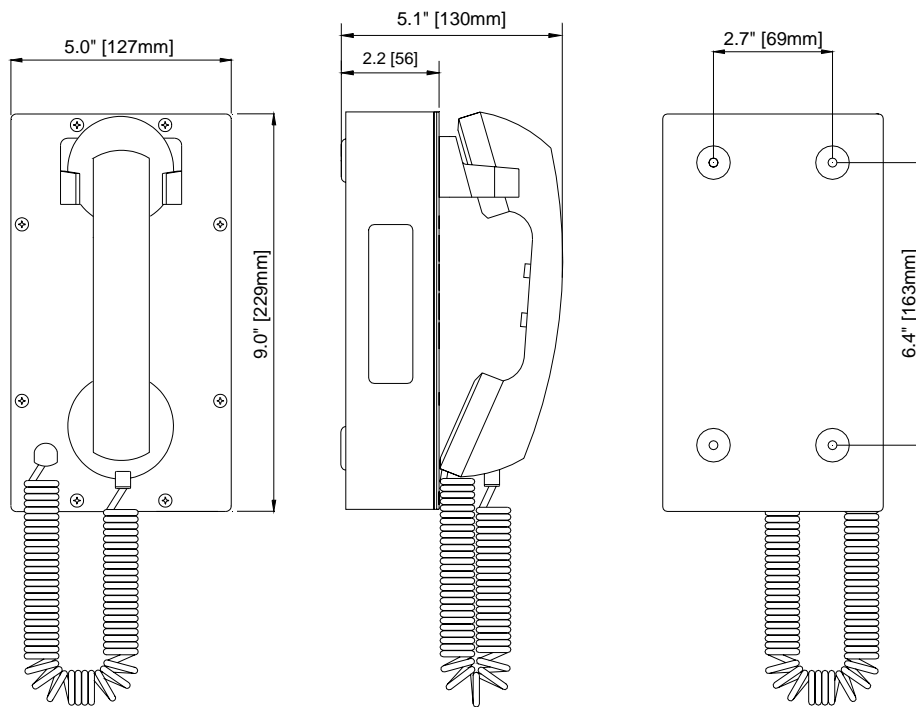

Figure 2 - Overall Dimensions

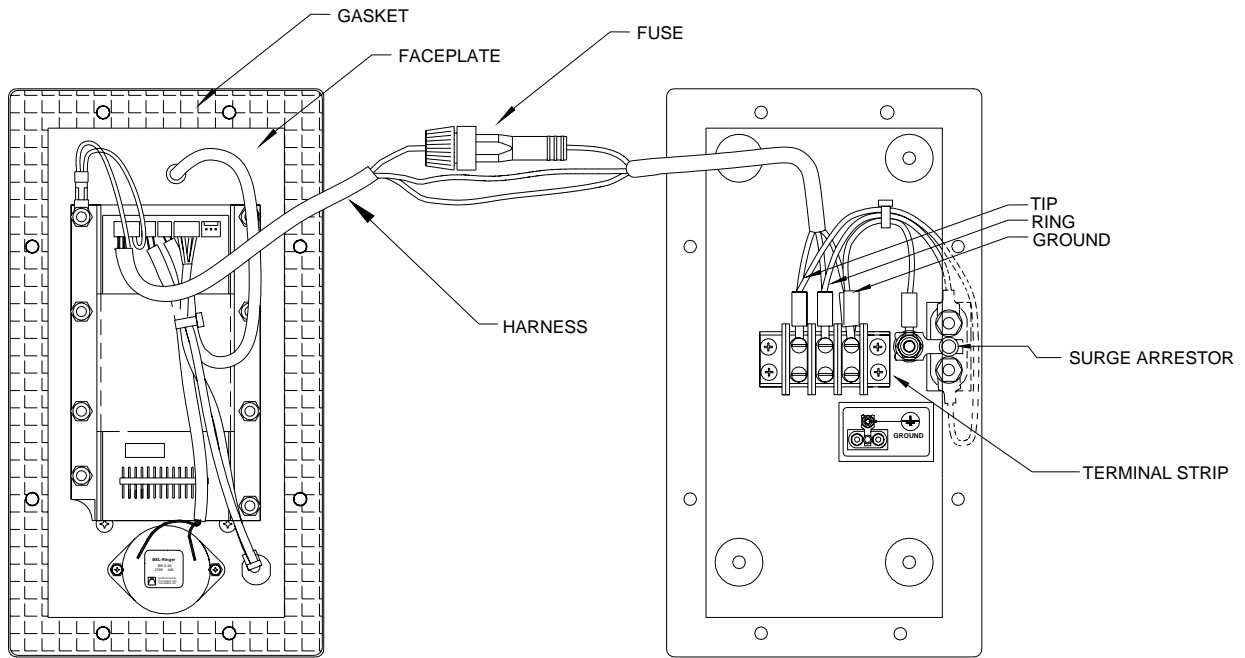

Figure 3 - Installation SCR-11

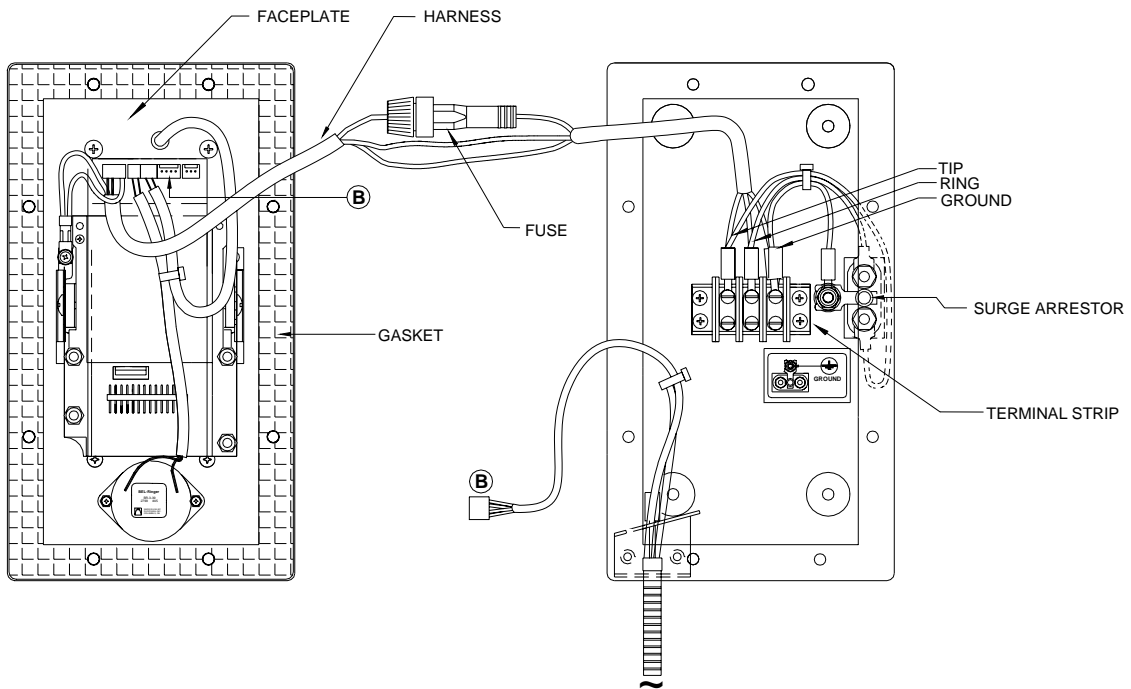

Figure 4 - Installation SCR-41

Installing the SCR

- Follow all appropriate electrical codes and use only approved electrical fittings for the installation.
- Choose a wall location that is free of obstructions and permits space for cable or conduit runs.
- Ensure mounting can support 4 lbs. (1.8 kg) and any additional foreseeable load.
- Ensure that none of the electrical connection circuits are live.
- Remove the eight (8) cover screws from the front of the unit and carefully remove the front cover assembly. NOTE that the handset and all electronics are attached to the front plate. The front cover may be separated from the back box by disconnecting the harness plugs.
- Use the template provided to locate and drill holes for #8 or M4 mounting screws.
- Attach the back box to the wall. If weather resistance is important in your application select washers that will assist in sealing the mounting holes.

See: Figure 2 - Overall Dimensions.

Tip: Use #8 or M4 screws to secure the unit to the wall.

Wiring the SCR to the Telephone System

- Fit an appropriate cable gland, grommet or conduit connector to the 7/8" opening in the bottom of the enclosure.
- Bring cable into the enclosure through the opening and attach individual wires from the exchange (Tip/Ring/Ground) to the connector (Tip & Ring are not polarity sensitive). If a conduit hub is used, ensure that it is grounded to the ground stud.
- Ensure all connections are tight, then replace and secure the cover.
- Connect the telephone into the system.
- The SCR Telephone may be supplied with an optional Auto Dialer or dialing may be configured by the PABX. If an Auto Dialer is ordered with the SCR, refer to the manual for the Auto Dialer for instructions on programming and for compliances.
- Test the unit by calling to and from another unit on the exchange.

See: Figure 3 - Installation SCR-11 & Figure 4 - Installation SCR-41

Operating the SCR

- The SCR Ringdown/Autodialer phone is designed for automatic calling simply by removing the handset from the cradle.

Field Repairs

Field repairs may only be carried out by qualified technicians using OEM parts. Substitution of parts voids warranty and may pose a hazard to users of the equipment.

- Disconnect the telephone from Tip and Ring power supplied by the PABX or central office before attempting to make repairs.
- Carefully remove the front cover assembly and separate from the housing by disconnecting the harness plugs. NOTE that the electronics are attached to the front plate.
- Perform the necessary repairs or adjustments.
- Carefully replace the front plate and install all eight screws. Do not over tighten the cover screws, there is a flexible gasket between the cover and the body. Excessive tightening of the screws deforms the gasket and reduces the weather resistance of the set.

Fuse Replacement

- Remove the old fuse by pushing in the end cap of the fuse holder and turning counterclockwise to open. Insert a new 0.25 amp, 250Volt, 3AG fast blow fuse and close the fuse holder.

WARNING!

- Replace only with a 0.25 amp 250V 3AG fast blow fuse. Failure to do so will void the warranty.
- If, on reconnecting power, the fuse fails, check the telephone system wiring. The fuse protects the Tip and Ring line from the telephone system. It is usually powered at 48 volts DC and must not be connected to 120 volts AC.

See: *Replacement Parts*

See: *Figure 3 - Installation SCR-11 & Figure 4 - Installation SCR-41*

See: *Figure 3 - Installation SCR-11 & Figure 4 - Installation SCR-41*

Engineering Specifications	
<i>ELECTRICAL PERFORMANCE</i>	
AUDIBLE RANGE FREQUENCY RESPONSE	300 – 3400 Hz
TRANSMIT OBJECTIVE LOUDNESS RATING (TOLR)	-38 +/- 3 dB
RECEIVER VOLUME ADJUSTMENT	+8.1 / -5.1 dB IN STEPS OF 2.7 dB
RECEIVE OBJECTIVE LOUDNESS RATING (ROLR)	
-AT NOMINAL VOLUME LEVEL	50 +/- 3 dB
-AT MAXIMUM VOLUME LEVEL	41.9 +/- 3 dB
-AT MINIMUM VOLUME LEVEL	55.4 +/- 3 dB
SIDE TONE OBJECTIVE LOUDNESS RATING (SOLR)	
-AT NOMINAL VOLUME LEVEL	11 +/- 4 dB
-AT MAXIMUM VOLUME LEVEL	7 +/- 4 dB
-AT MINIMUM VOLUME LEVEL	14 +/- 4 dB
RINGER OUTPUT	>75 dB
FCC RINGER EQUIVALENCE	0.8B
SET IMPEDANCE	600 OHMS NOMINAL
MAXIMUM LOOP	15,000 FEET (4,600 METERS) OF 22 AWG COPPER
<i>ELECTRICAL REQUIREMENTS</i>	
RINGER SENSITIVITY	40 – 100 V, 16 – 25 HZ
LINE VOLTAGE	24 – 56 VDC
LOOP CURRENT	20 - 120 mA
CONNECTION METHOD	SURGE ARRESTOR / TERMINAL BLOCK
<i>ENVIRONMENTAL</i>	
WEATHERPROOF	ENCLOSURE NEMA 3R
TEMPERATURE	-40° TO +60° C (-40° TO +140° F)
<i>MECHANICAL</i>	
HOOK SWITCH (CRADLE SWITCH) LIFE	>1 000 000 OPERATIONS
BODY CONSTRUCTION	16 GAUGE STEEL, ZINC DICHROMATE PLATED AND POWDER COATED
DIMENSIONS (H x W x D)	9 x 5.0 x 5.2 INCHES (229 x 127 x 132 MM)
NET WEIGHT	4 LBS (1.82 KG)
HANDSET MATERIAL	HIGH IMPACT ABS
MICROPHONE	NOISE REDUCING ELECTRET
OPTIONAL MICROPHONE	NOISE CANCELING DYNAMIC
RECEIVER	HEARING AID COMPATIBLE

STANDARD MOUNTING	VERTICAL WALL
CONNECTION FITTINGS	7/8" DIAM. OPENING FOR OWNER SUPPLIED FITTING
HARDWARE MATERIAL	STAINLESS STEEL
COMPLIANCES	
INDUSTRY CANADA	1012 6721 A
FCC	HQHCAN-22517-TE-E

Accessories

- P7224 Potted ring detect relay
- P7225 Weather Proof ring detect relay
- P7227 Potted off-hook detect relay
- P7232 Weather Proof off-hook detect relay
- PXXXX External Loud Ringer

Replacement Parts	
Part No.	Description
P004026	Faceplate SCR-11
P006263	Faceplate SCR-41
P005479	Handset Shell C/W Volume Control & 22" Armored Cord
P005477	Handset Shell C/W Volume Control & 6' Curly Cord
P002786	Handset Cradle
P004371	Handset Retainer – SCR-41 Only
P000028	Microphone Cartridge – Noise Reducing
P004538	Microphone Cartridge – Noise Canceling
P002080	Receiver Cartridge
P005391	Handset Assembly – C/W Volume Control & 6' Curly Cord For SCR-11
P005699	Handset Assembly – C/W Volume Control & 22" Armored Cord For SCR-41
P005582	Telephone Circuit Board
P002782	Ringer – Floyd Bell BR-3-39
P005917	Reed Switch
P002992	Surge Arrestor – TII 126L1
P002991	Fuse – Glass 0.25 Amp 250V
P002840	Housing SCR-11
P004152	Housing SCR-41
P002787	Gasket – Faceplate

Warranty

Guardian Telecom warrants your product to be free of defects in material and workmanship for a period of one year. Guardian Telecom will repair or replace any defective unit that is under warranty

This warranty is null and void if any non-authorized modifications have been made to this product, or if it has been subjected to misuse, neglect, or accident. This warranty covers bench repairs only; such repairs must be made at Guardian Telecom or an authorized service depot. Guardian Telecom is not responsible for costs incurred for on-site service calls, freight, or brokerage.

A return authorization must be obtained prior to warranty claims or repairs.

Disclaimer

The products covered by this manual are designed for use in Industrial Environments and/or Hazardous Locations. Due to the range of possible applications for these instruments the manufacturer will not be responsible for damages or losses of any kind suffered as a result of the use of this product, including consequential damages.

Warning

This device may be opened and reassembled by qualified personnel only, for the purposes of installing the product, making adjustments and replacing components, following the instructions in the product manual.

High voltages may be present in this product when connected to telephone wiring.

Service Telephone Number

1-800-363-8010

Guardian Telecom provides a customer service telephone number which is toll-free within North America. If you need assistance when installing or operating this product, please call the toll-free telephone number between regular business hours (8:00AM-5:00PM), Mountain Standard Time. If you are calling outside of regular business hours, please leave a detailed message, and a member of Guardian Telecom's Service Department will return your call as soon as possible. If your product requires service, Guardian personnel will supply you with an RMA (return materials authorization) number over the telephone or through our web site product return page. This number must be included with your return address and the name of the person to contact.

**Guardian Telecom Inc.
7552 - 10th Street N.E.
Calgary, Alberta, Canada T2E 8W1
Toll-free 1-800-363-8010
Ph. (403) 258-3100
Fax. (403) 253-4967
www.guardiantelecom.com**

Feedback

Guardian Telecom continually strives to make reliable, durable, and easy to use products. If you, as an installer or user of our equipment, have any suggestions for improvements to this or any of our products or documents, including this manual, we would appreciate hearing from you.

Guardian Product Return
Guardian products have been quality tested and are in full working order when shipped from the factory, given the rugged nature of these products shipping is not expected to damage a unit. In the unlikely event of a malfunction, Guardian follows the three step procedure below.
<i>Step I - On-Site Correction</i>
<ul style="list-style-type: none"> • The most common source of difficulties with a new product is improper installation in one of two ways: incorrect wiring connections or connection to an incorrect power source.
<ul style="list-style-type: none"> • Product wiring needs to be properly connected to the on-site wiring. Correct wiring instructions are shown in the user manual included with the product.
<ul style="list-style-type: none"> • Connecting a telephone to a standard power source, rather than tip & ring, will blow the telephone's internal, user-replaceable fuse. In the event of fuse burn-out, disconnect the telephone from the power source, replace the fuse, and reconnect following the wiring diagrams provided with the product.
<i>Step II - Return Materials Authorization (RMA)</i>
<ul style="list-style-type: none"> • When a product has been installed following user manual instructions, and the unit fails to operate, the user must contact Guardian Telecom to obtain authorization to return the product. This can be done by completing a RMA form online at www.guardiantelecom.com, or by calling the service telephone number given in this manual.
<ul style="list-style-type: none"> • After providing information on the product, the owner and the nature of the problem, Guardian will issue a RMA number, to be shown on documentation returned with the product.
<ul style="list-style-type: none"> • In addition to the RMA number, shipping documents should include name, address and telephone number of the owner along with contact information for the person responsible for the repair and/or the user who identified the malfunction.
<ul style="list-style-type: none"> • (Where a product is being returned for repair from outside of Canada, customs documentation must show the product's serial number, date of export [date of purchase], and a notation that the equipment is: "Canadian goods returning.")
<i>Step III - Factory Authorized Service</i>
<ul style="list-style-type: none"> • Once received, each product is carefully inspected and tested. If the product is under warranty, repairs are completed and the product returned to the owner, generally within five working days of receipt by the factory.
<ul style="list-style-type: none"> • A product that has been subjected to misuse, neglect or accident or is beyond the warranty period will be evaluated. The service department will provide the owner's representative with a repair cost estimate. Once approved, repairs are completed and the product returned, generally within five working days.



**Guardian Telecom Inc.
7552 - 10th Street N.E.
Calgary, Alberta, Canada T2E 8W1
Toll-free 1-800-363-8010
Ph. (403) 258-3100
Fax. (403) 253-4967
www.guardiantelecom.com**

E-mail: <mailto:sales@guardiantelecom.com>
(Click to open message box)

Industrial Communications Worldwide