



Assembly Instructions for Armrest No. CH25A

PARTS LIST

KEY	QTY	DESCRIPTION
1	2	P.U. ARMREST
2	2	ARM PLATE (PRE-ASSEMBLED TO KEY 1)
3	1	SUPPORTING BAR
4	2	LOCK WASHER
5	2	FLAT WASHER
6	2	ADJUSTMENT KNOB
7	4	M6x26mm MACHINE SCREW

INSTRUCTIONS :

STEP 1

USE (7) SCREWS TO FIX THE (3) SUPPORTING BAR TO YOUR CHAIR MECHANISM AS DRAWN BELOW.

STEP 2

INSERT (2) ARM PLATE INTO (3) SUPPORTING BAR. ALIGN THE PRE-DRILLED HOLES OF (2) ARM PLATE AND (3) SUPPORTING BAR AND THEN INSERT THE (6) ADJUSTMENT KNOB WITH (4) LOCK WASHER & (5) FLAT WASHER UPWARD INTO THE HOLE OF (3) SUPPORTING BAR AND TIGHTEN KNOBS FIRMLY.

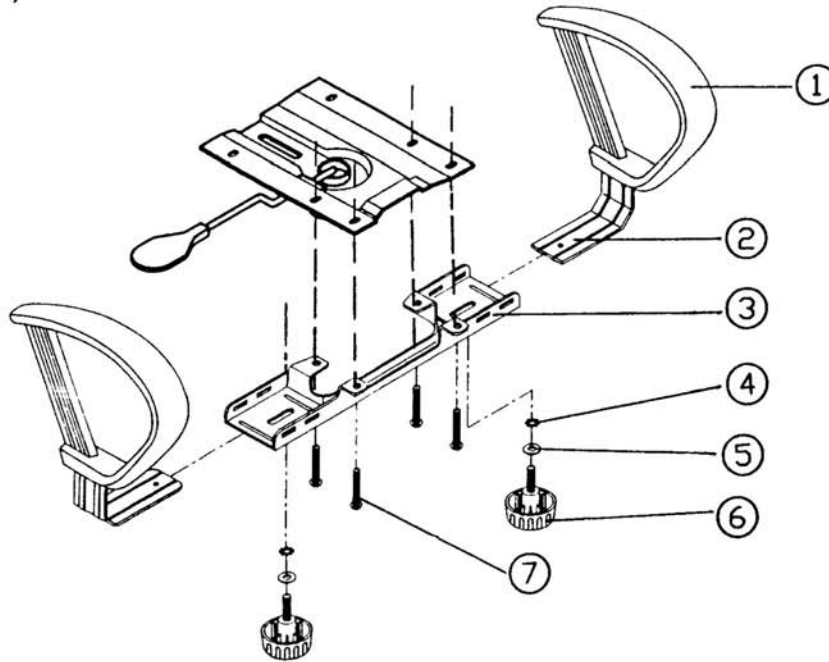

WARNING!

- ◆ USE THIS PRODUCT FOR SEATING ONLY ONE PERSON AT A TIME. DON'T USE AS A STEP LADDER.
- ◆ DO NOT USE THIS CHAIR UNLESS ALL BOLTS, SCREWS AND KNOBS ARE SECURELY TIGHTENED.
- ◆ AT LEAST EVERY SIX MONTHS, CHECK ALL BOLTS, SCREWS AND KNOBS TO BE SURE THEY ARE SECURELY TIGHTENED.
- ◆ IF ANY COMPONENT IS MISSING, DAMAGED OR WORN, STOP USE OF THE PRODUCT UNTIL REPAIRS CAN BE MADE. CONTACT FOR FACTORY AUTHORIZED REPAIR PARTS. FAILURE TO FOLLOW THESE WARNINGS MAY RESULT TO SERIOUS INJURY.