

50XP
Performance™ 13 SEER
Single-Packaged Air Conditioner System with Puron®
(R-410A) Refrigerant Single and Three Phase
2 to 5 Nominal Tons (Sizes 024-060)

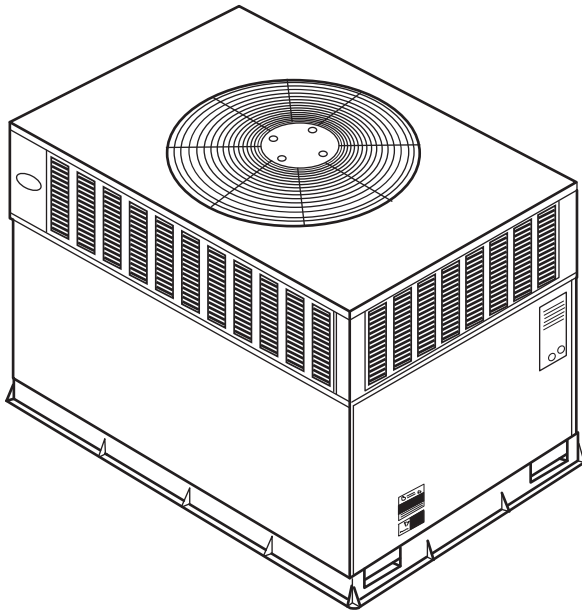

Turn to the Experts.™

Product Data



C99064

Fig. 1 - Unit 50XP

Single-Packaged Products with Energy-Saving Features and Puron® refrigerant.

- Up to 13.5 SEER
- Factory-Installed TXV
- Variable Speed Blower-Standard
- Low Sound Levels

FEATURES/BENEFITS

One-piece cooling unit with optional electric heater, low installation cost, dependable performance and easy maintenance.

Efficient operation

High-efficiency design with a SEER (Seasonal Energy Efficiency Ratio) of up to 13.5.

Puron Environmentally Sound Refrigerant is Carrier's unique refrigerant designed to help protect the environment. Puron is an HFC refrigerant which does not contain chlorine that can harm the ozone layer. Puron refrigerant is in service in millions of systems proving highly reliable, environmentally sound performance.

IdealHumidity Technology featuring Thermidistat control and Variable Speed Blower motor that provides greater comfort, humidity control, and energy efficiency. You can expect up to 30 times better dehumidification; economical constant fan for less than \$50 a year, which provides improved indoor air quality and more even temperatures from room to room; and reduced indoor noise due to lower air velocity. In addition, you'll realize improved installation flexibility with 3 different airflow choices for best overall comfort.

Easy Installation

Factory-assembled package is a fully self-contained, electric cooling unit that is prewired, pre-piped, and pre-charged for minimum installation expense. These units are available in a variety of standard cooling sizes with voltage options to meet residential and light commercial requirements. Units are lightweight and install easily on a rooftop or at ground level. The high tech composite base eliminates rust problems associated with ground level applications.

Durable, dependable components

Scroll Compressors are designed for high efficiency. Each compressor is hermetically sealed against contamination to help promote longer life and dependable operation. Each compressor also has vibration isolation to provide quieter operation. All compressors have internal high pressure and overcurrent protection.

Convertible duct configuration

Unit is designed for easy use in either downflow or horizontal applications. Each unit is easily converted from horizontal to downflow. Downflow operation is easily provided in the field to allow vertical ductwork connections. The basepan utilizes knockout style seals on the bottom openings to ensure a positive seal in the horizontal airflow mode.

Direct-drive variable speed blower motor is standard on all models.

Direct-drive PSC condenser-fan motors are designed to help reduce energy consumption and provide for cooling operation down to 55°F (13°C) outdoor temperature. Motormaster® II low ambient kit is available as a field-installed accessory.

Thermostat controls

Time Guard® II anti-short cycle protection circuitry. If a non-corporate thermostat without anti-short cycle protection is used the Time Guard II field-installed anti-short cycle kit is recommended.

Refrigerant system is designed to provide dependability. Liquid filter driers are used to promote clean, unrestricted operation. Each unit leaves the factory with a full refrigerant charge. Refrigerant service connections make checking operating pressures easier.

Thermostatic Expansion Valve - A hard shutoff, balance port TXV maintains a constant superheat at the evaporator exit (cooling cycle) resulting in higher overall system efficiency.

Evaporator and condenser coils are computer-designed for optimum heat transfer and cooling efficiency. The evaporator coil is fabricated from copper tube and aluminum fins and is located inside the unit for protection against damage. The condenser coil is internally mounted on the top tier of the unit. Copper fin coils and pre-coated fin coils are available from the factory by special order. These coils are recommended in applications where aluminum fins are likely to be damaged due to corrosion. They are ideal for seacoast applications.

High and Low Pressure Switches provide added reliability for the compressor.

Low sound ratings ensure a quiet indoor and outdoor environment with sound ratings as low as 72dBA. (See Page 4.)

Easy to service cabinets provide easy single-panel accessibility to serviceable components during maintenance and installation. The basepan with integrated drain pan provides easy ground level installation with or without a mounting pad. Convenient handholds are provided to manipulate the unit on the jobsite. A nesting feature ensures a positive basepan to roof curb seal when the unit is roof mounted. A convenient 3/4-in. (19.05 mm) wide perimeter flange makes frame mounting on a rooftop easy.

Louvered Grille provides hail and vandalism protection for the coil.

Cabinets are constructed of heavyduty, phosphated, zinc-coated prepainted steel capable of withstanding 500 hours of salt spray. Interior surfaces of the evaporator and electric heater compartments are insulated with cleanable semi-rigid insulation board, which keeps the conditioned air from being affected by the outdoor ambient temperature and provides improved indoor air quality. (Conforms to American Society of Heating, Refrigeration and Air Conditioning Engineers No. 62P.) The sloped drain pan minimizes standing water in the drain. An external drain is provided.

TABLE OF CONTENTS

- FEATURES/BENEFITS 1-2
- MODEL NUMBER NOMENCLATURE 3
- ARI CAPACITIES 4
- PHYSICAL DATA 5
- OPTIONS AND ACCESSORIES 6
- BASE UNIT DIMENSIONS 8-9
- ACCESSORY ROOF CURB 10
- SELECTION PROCEDURE 11
- PERFORMANCE DATA 12-16
- TYPICAL PIPING AND WIRING 17
- APPLICATION DATA 18
- ELECTRICAL DATA 19-20
- TYPICAL WIRING SCHEMATICS 21-23
- CONTROLS 24
- GUIDE SPECIFICATIONS 25-26

MODEL NUMBER NOMENCLATURE

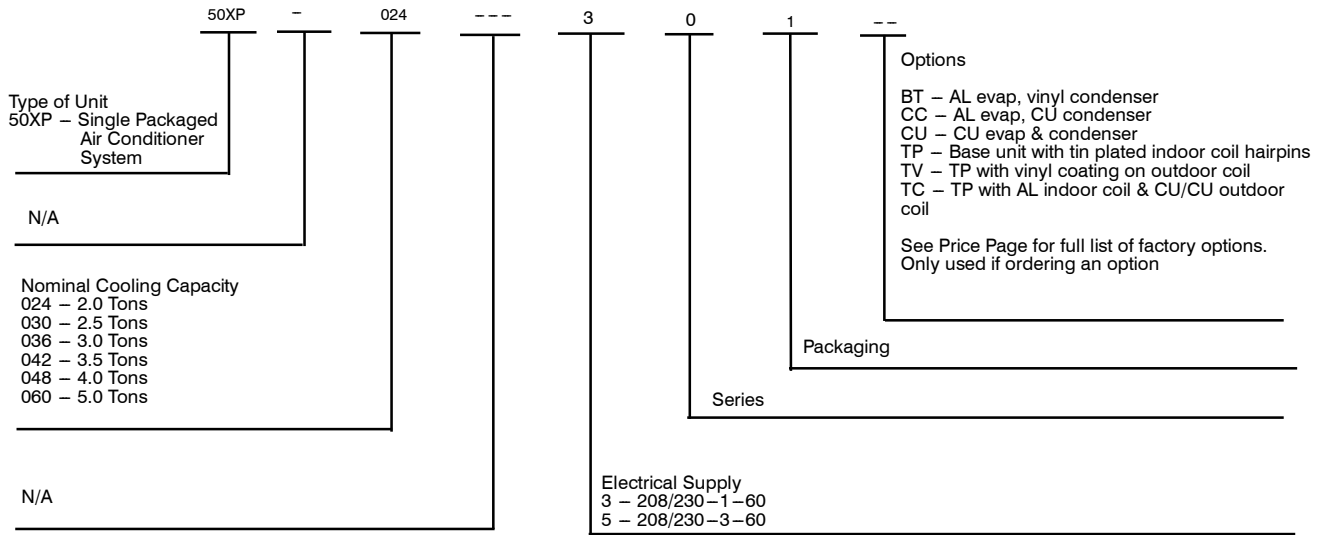

50XP

LEGEND
AL – Aluminum
CU – Copper



ARI* CAPACITIES

Cooling Capacities and Efficiencies

UNIT 50XP	NOMINAL TONS	STANDARD CFM	NET COOLING CAPACITIES (Btuh)	EER**	SEER†
024	2	770	24,000	11.0	13.2
030	2-1/2	960	29,000	11.0	13.0
036	3	1100	36,000	11.2	13.5
042	3-1/2	1450	41,000	11.2	13.0
048	4	1450	45,000	11.0	13.0
060	5	1710	57,000	11.0	13.0

LEGEND

dB—Sound Levels (decibels)

db—Dry Bulb

SEER—Seasonal Energy Efficiency Ratio

wb—Wet Bulb

COP—Coefficient of Performance

* Air Conditioning & Refrigeration Institute.

**At "A" conditions—80°F (26.7°C) indoor db/67°F (19.4°C) indoor wb & 95°F (35°C) outdoor db.

† Rated in accordance with U.S. Government DOE Department of Energy) test procedures and/or ARI Standards 210/240.

Notes:

1. Ratings are net values, reflecting the effects of circulating fan heat.

Ratings are based on:

Cooling Standard: 80°F (26.7°C) db, 67°F wb (19.4°C) indoor entering—air temperature and 95°F db (35°C) outdoor entering—air temperature.

2. Before purchasing this appliance, read important energy cost and efficiency information available from your retailer.

50XP

A-Weighted Sound Power (dBA)

50XP	STANDARD RATING (dBA)	TYPICAL OCTAVE BAND SPECTRUM (dBA) (without tone adjustment)						
		125	250	500	1000	2000	4000	8000
024	72	58.8	63.5	67.2	66.9	63.7	58.3	50.0
030	72	58.8	63.5	67.2	66.9	63.7	58.3	50.0
036	72	60.7	63.3	66.8	66.5	64.2	60.3	53.0
042	72	56.7	62.8	67.8	67.4	63.7	57.7	50.8
048	78	62.4	69.9	71.3	73.4	70.0	66.3	60.1
060	78	63.5	67.6	71.8	75.5	71.0	68.1	59.9

* Tested in accordance with ARI Standard 270 (not listed in ARI).

PHYSICAL DATA

Physical Data-Unit 50XP

UNIT SIZE	024	030	036	042	048	060
NOMINAL CAPACITY (ton)	2	2-1/2	3	3-1/2	4	5
SHIPPING WEIGHT (lb)	356	360	378	436	470	515
SHIPPING WEIGHT (kg)	161	163	171	198	213	234
COMPRESSORS	Scroll					
Quantity	1					
REFRIGERANT (R-410A)						
Quantity (lb.)	7.3	8.0	9.5	10.7	11.25	13.2
Quantity (kg)	3.3	3.6	4.3	4.9	5.1	6.0
REFRIGERANT METERING DEVICE	TXV					
OUTDOOR COIL						
Rows...Fins/in.	2...21	2...21	2...21	2...21	2...21	2...21
Face Area (sq ft)	11.95	12.0	13.6	15.4	17.4	19.3
OUTDOOR FAN						
Nominal Cfm	2350	2700	2350	2800	3300	3300
Diameter (in.)	22	22	22	22	22	22
Diameter (mm)	558.8	558.8	558.8	558.8	558.8	558.8
Motor Hp (Rpm)	1/8 (825)	1/8 (825)	1/8 (825)	1/8 (825)	1/4 (1100)	1/4 (1100)
INDOOR COIL						
Rows...Fins/in.	3...15	3...15	4...15	3...15	4...15	4...17
Face Area (sq ft)	3.7	3.7	3.7	4.7	4.7	5.7
INDOOR BLOWER						
Nominal Cooling Airflow (Cfm)	800	1000	1100	1400	1400	1750
Size (in.)	10x10	10x10	11x10	11x10	11x10	11x10
Size (mm.)	254x254	254x254	279.4x254	279.4x254	279.4x254	279.4x254
Motor HP (RPM)	1/2 (1050)	1/2 (1050)	3/4 (1000)	3/4 (1075)	3/4 (1075)	1.0 (1040)
HIGH-PRESSURE SWITCH (psig) Cut-out Reset (Auto)	650 +/- 15 420 +/- 25					
LOSS-OF-CHARGE / LOW-PRESSURE SWITCH (Liquid Line) (psig) cut-out Reset (auto)	20 +/- 5 45 +/- 10					
RETURN-AIR FILTERS†‡						
Throwaway Size (in.)	20x20x1		20x24x1	24x30x1		
Throwaway Size (mm)	508x508x25		508x610x25	610x762x25		

† Required filter sizes shown are based on the larger of the ARI (Air Conditioning and Refrigeration Institute) rated cooling airflow or the heating airflow velocity of 300 ft/minute for throwaway type or 450 ft/minute for high-capacity type. Air filter pressure drop for non-standard filters must not exceed 0.08 IN. W.C..

‡ If using accessory filter rack refer to the filter rack installation instructions for correct filter sizes and quantity.

50XP

OPTIONS AND ACCESSORIES

Factory-installed options

Coil options include Tin-Plated* indoor hairpins, copper/copper and vinyl-coated construction for refrigerant coils. Units are shipped standard with copper tube/aluminum fin construction. See model number nomenclature for coil options.

*Tin-Plated indoor coils are built with special hairpins that are designed to resist both general pitting corrosion and excessive indoor corrosion (Formicary Corrosion).

Field-installed accessories

Economizer with Solid-State Controls and Barometric Relief Dampers
Manual Air Damper (25% open)
Electric Heaters
Filter Rack
Flat Roof Curbs (8-in. and 14-in.) (203.2 and 355.6 mm)
Square-to-Round Duct Transition Kit
Thermidistat™
Thermostats
Crankcase Heater
Compressor Start Kit (for use on single-phase units only)
Rigging Kit
Low Ambient Kit (Motormaster® II Control)
Solid-State Time Guard® II Device
Lifting Kit

Economizer with solid-state controls and barometric relief dampers includes filter racks and provide outdoor air during cooling and reduce compressor operation.

Manual outside air damper includes hood and filter rack with adjustable damper blade for up to 25% outdoor air.

Electric heaters provide additional heat in the unit when required. Each package has a heater module that slides into the controls

Electric Heaters

CATALOG ORDERING NO.	NOMINAL CAPACITY (kW)	FUSES	USED WITH SIZES					
			024	030	036	042	048	060
ELECTRIC HEATERS (208/230 — SINGLE PHASE — 60 Hz)								
CPHEATER052A00	5.0	0	X	X	X	X	X	X
CPHEATER069A00	7.5	0	X	X	X	X	X	X
CPHEATER065A00	10.0	0	X	X	X	X	X	X
CPHEATER051A00	15.0	4		X	X	X	X	X
CPHEATER053A00	20.0	6				X	X	
CPHEATER054A00	20.0	6						X
ELECTRIC HEATERS (208/230 — THREE PHASE — 60 Hz)								
CPHEATER055A00	5.0	0		X	X	X	X	X
CPHEATER056A00	10.0	0		X	X	X	X	X
CPHEATER057A00	15.0	0			X	X	X	X
CPHEATER059A00	20.0	6				X	X	X

NOTE: Electric heaters are rated at 240v. Refer to Multiplication Factors table for other voltages.

X = Approved combinations.

Minimum Airflow for Reliable Electric Heater Operation (CFM)

UNIT SIZE	024	030	036	042	048	060
AIRFLOW	750	1000	1250	1400	1500	1800

compartment. Heater sizes range from 5.0 to 20.0 kW. The electric heater design allows the use of a single-point power supply for the entire unit, resulting in lower installed costs.

Filter Rack features easy installation, serviceability, and high-filtering performance for vertical or horizontal applications.

Flat roof curbs in both 8 in. (203.2 mm) and 14 in. (355.6 mm) sizes are available for roof mounted applications.

Square-to-round duct transition kit enables 024-048 size units to be fitted to 14 in. (355.6 mm) round ductwork.

Thermidistat Control coupled with the system's variable speed indoor blower delivers Carrier's patented IdealHumidity Technology that allows for even greater humidity control. Along with more precisely controlling temperature and humidity, the Thermidistat offers full seven-day programmability allowing you to further customize your comfort and energy savings.

Thermostats provide control for the system heating and cooling functions. Thermostat models are available in both programmable and non-programmable versions.

Crankcase Heater provides anti-floodback protection for low-load cooling applications.

Compressor start kit assists compressor start-up by providing additional starting torque on single phase units and prolongs compressor motor life.

Rigging kit includes lifting brackets which are inserted into the unit base rigging holds to lift unit for rooftop applications.

Low-ambient kit (Motormaster II control) allows the use of mechanical cooling down to outdoor temperatures as low as 0°F (-17°C) when properly installed.

Solid-state Time Guard II device provides short-cycling protection for the compressor. Not required with corporate electronic thermostats.

Lifting kit, including 4 metal brackets that are available to assist in lifting this product onto a roof application.

ECONOMIZER

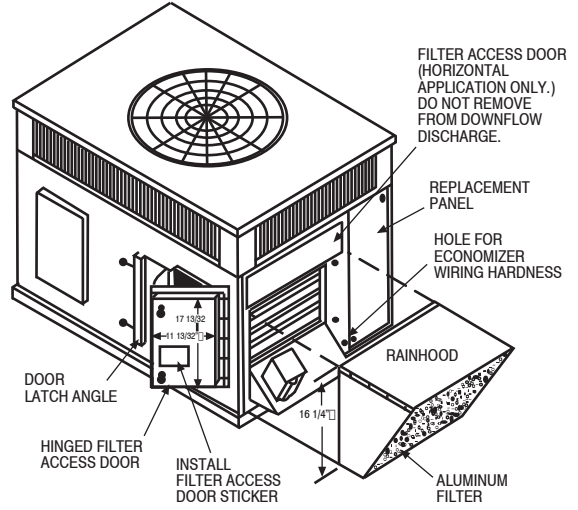
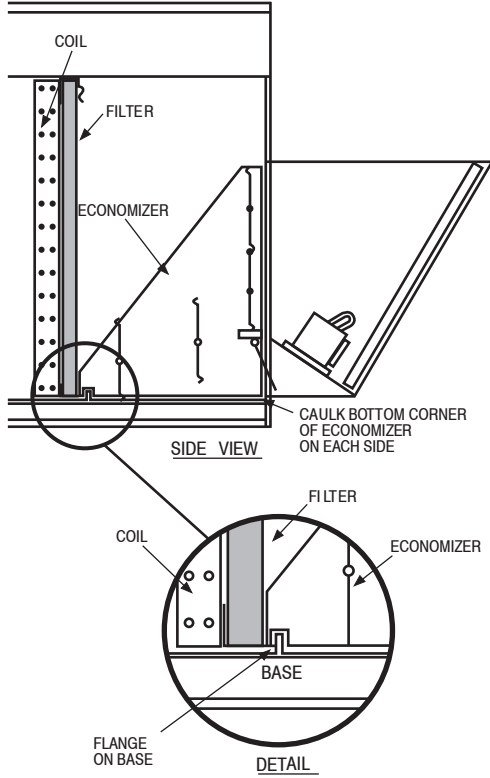

50XP

FILTER RACK

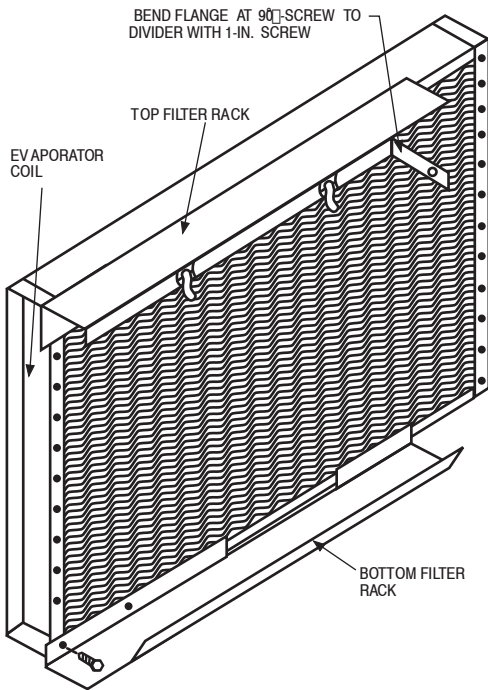

MANUAL OUTSIDE AIR DAMPER

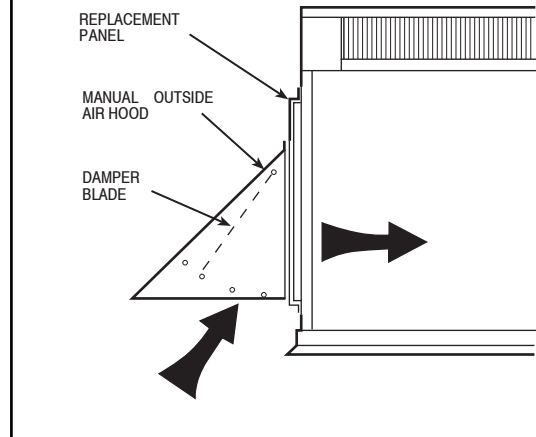

UNIT DIMENSIONS - 50XP024-036

50XP

UNIT	ELECTRICAL CHARACTERISTICS			CENTER OF GRAVITY MM/IN		
	LBS.	KG.	"A"	X	Y	Z
50XP024	208-230-1-60, 208/230-3-60	140	1091.7 (42.98)	495.3 (19.5)	447.6 (17.6)	457.2 (18.0)
50XP030	208-230-1-60, 208/230-3-60	312	1142.5 (44.98)	495.3 (19.5)	447.6 (17.6)	457.2 (18.0)
50XP036	208-230-1-60, 208/230-3-60	330	1193.3 (46.98)	533.4 (21.0)	508.0 (20.0)	442.0 (17.6)

REQUIRED CLEARANCES TO COMBUSTIBLE MATL.

CORNER WEIGHT LBS./KG.	1"	2"	3"	4"
024	62/28	49/22	74/34	123/56
030	62/28	50/23	75/34	125/57
036	66/30	53/24	79/36	132/60

TOP OF UNIT 355.6 (14.00)
 DUCT SIDE OF UNIT 50.8 (2.00)
 SIDE OPPOSITE DUCTS 355.6 (14.00)
 BOTTOM OF UNIT 0 (0.00)
 ELECTRIC HEAT PANEL 914.4 (36.00)

NEC. REQUIRED CLEARANCES.

BETWEEN UNITS, POWER ENTRY SIDE 1066.8 (42.00)
 UNIT AND UNGROUNDED SURFACES, POWER ENTRY SIDE 914.0 (36.00)
 UNIT AND BLOCK OR CONCRETE WALLS AND OTHER GROUNDED SURFACES, POWER ENTRY SIDE 1066.8 (42.00)

REQUIRED CLEARANCES FOR OPERATION AND SERVICING

EVAP. COIL ACCESS SIDE MILLIMETERS (IN)
 POWER ENTRY SIDE 914.0 (36.00)
 UNIT TOP FOR NEC REQUIREMENTS 914.0 (36.00)
 UNIT TOP 1219.2 (48.00)
 SIDE OPPOSITE DUCTS 914.0 (36.00)
 DUCT PANEL 304.8 (12.00)*

*MINIMUM DISTANCES: IF UNIT IS PLACED LESS THAN 304.8 (12.00) FROM WALL SYSTEM, THEN SYSTEM PERFORMANCE MAYBE COMPROMISED.

DIMENSIONS IN () ARE IN INCHES

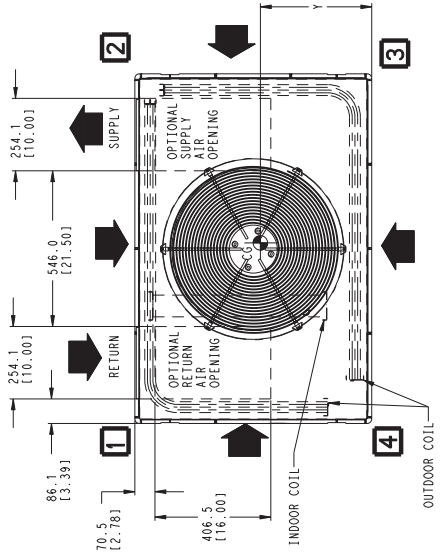

TOP VIEW

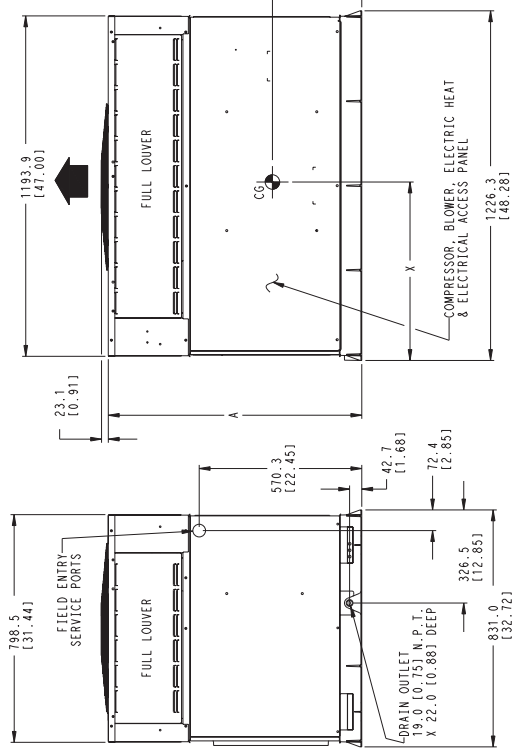

FRONT VIEW

LEFT SIDE VIEW

RIGHT SIDE VIEW

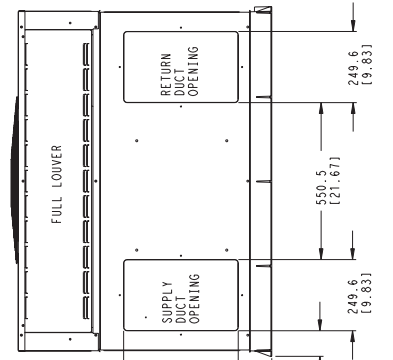

REAR VIEW

REV	3.0
50XP500017	

UNIT DIMENSIONS - 50XP042-060

UNIT	ELECTRICAL CHARACTERISTICS		UNIT HEIGHT		CENTER OF GRAVITY MM/IN	
	LBS./KG.	"A"	"A"	X	Y	Z
50XP042	208-230-1-60, 208/230-3-60	1091	7142.98	495.3	117.6	457.2
50XP048	208-230-1-60, 208/230-3-60	1142	7144.98	495.3	117.6	457.2
50XP060	208-230-1-60, 208/230-3-60	1193	7146.98	533.4	121.0	508.0

REQUIRED CLEARANCES TO COMBUSTIBLE MATL.

CORNER WEIGHT LBS./KG.	"1"		"2"		"3"		"4"	
	"1"	"2"	"3"	"4"	"1"	"2"	"3"	"4"
042	78/35	62/28	93/42	155/70				
048	84/38	68/31	101/46	169/77				
060	93/42	75/34	112/51	187/85				

MILLIMETERS (IN)
 TOP OF UNIT.....355.6 (14.00)
 DUCT SIDE OF UNIT.....350.8 (13.81)
 SIDE OPPOSITE DUCT.....355.6 (14.00)
 BOTTOM OF UNIT.....0 (0.00)
 ELECTRIC HEAT PANEL.....914.4 (36.00)

NEC. REQUIRED CLEARANCES.

BETWEEN UNITS, POWER ENTRY SIDE.....1066.8 (42.00)
 UNIT AND UNGROUNDED SURFACES, POWER ENTRY SIDE.....914.0 (36.00)
 UNIT AND BLOCK OR CONCRETE WALLS AND OTHER GROUNDED SURFACES, POWER ENTRY SIDE.....1066.8 (42.00)

REQUIRED CLEARANCE FOR OPERATION AND SERVICING

EVAP. COIL ACCESS SIDE.....914.0 (36.00)
 POWER ENTRY SIDE.....914.0 (36.00)
 (EXCEPT FOR NEC REQUIREMENTS)
 UNIT TOP OPPOSITE DUCTS.....1219.2 (48.00)
 SIDE OPPOSITE DUCTS.....1066.8 (42.00)
 DUCT PANEL.....304.8 (12.00)

*MINIMUM DISTANCES IF UNIT IS PLACED LESS THAN 304.8 (12.00) FROM WALL SYSTEM, THEN SYSTEM PERFORMANCE MAYBE COMPROMISED.

DIMENSIONS IN () ARE IN INCHES

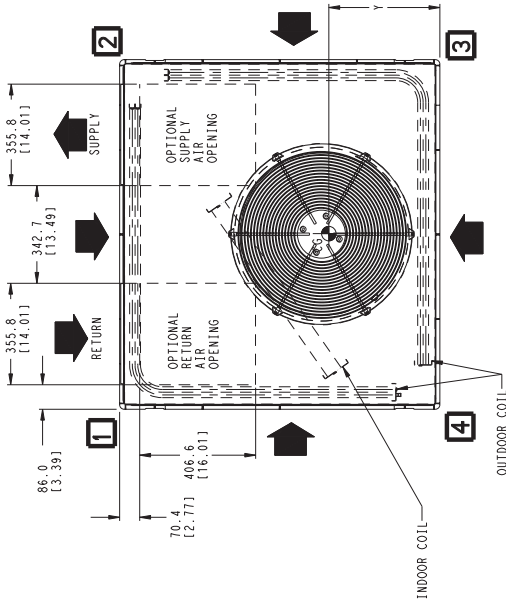

TOP VIEW

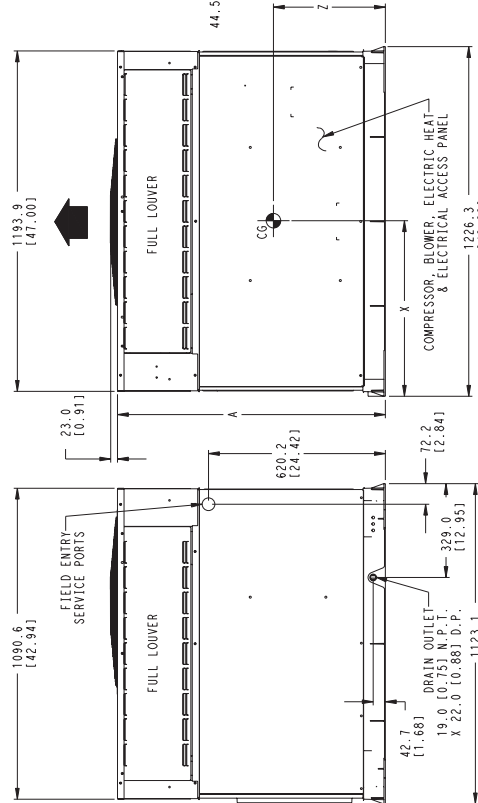

FRONT VIEW

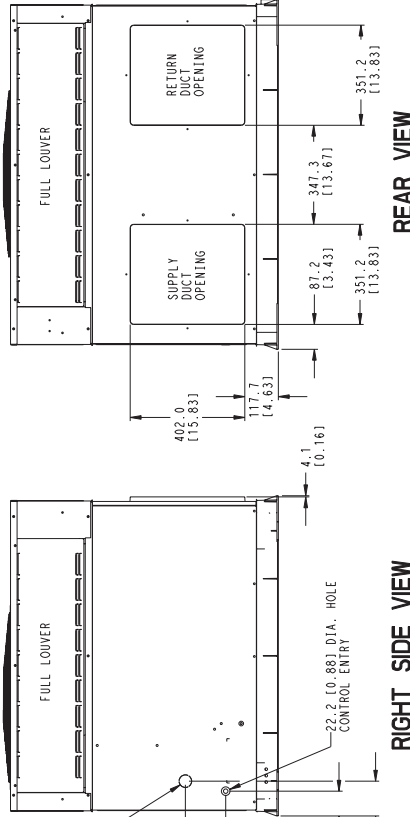

RIGHT SIDE VIEW

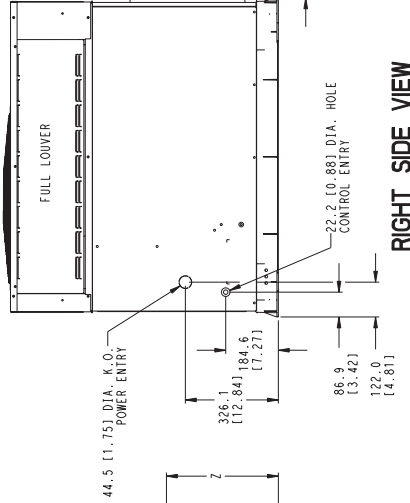

REAR VIEW

ACCESSORY ROOF CURB - 50XP024-060

50XP

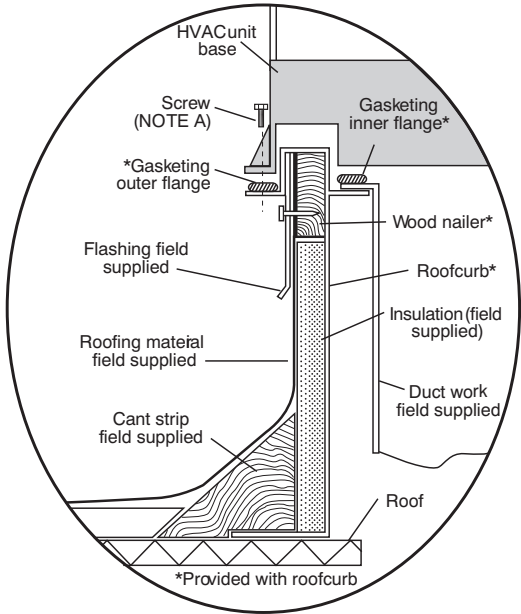

Roof Curb for Small Cabinet

Note A: When unit mounting screw is used, retainer bracket must also be used.

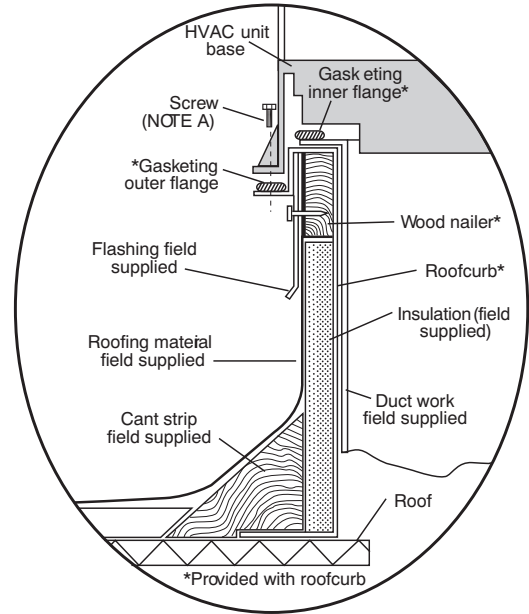

Roof Curb for Large Cabinet

Note A: When unit mounting screw is used, retainer bracket must also be used.

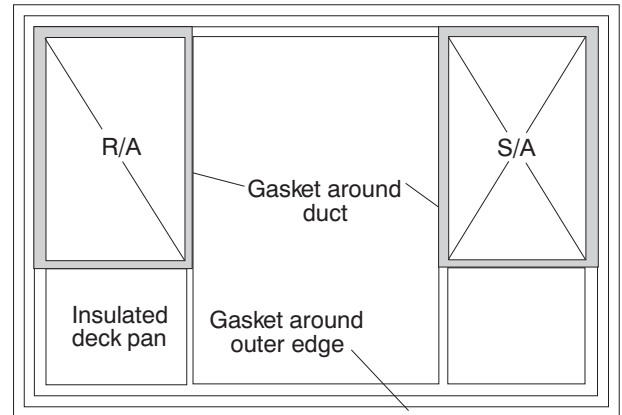
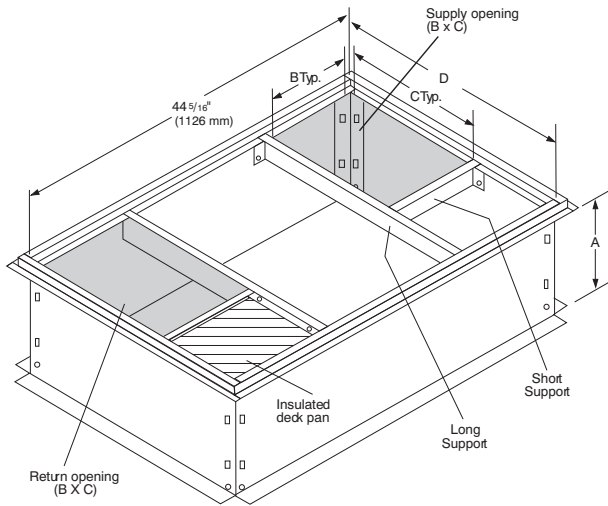

C00076

UNIT SIZE	ORDERING NUMBER	A IN. (MM)	B IN. (MM)	C IN. (MM)	D IN. (MM)
50XP024-036	CPRFCURB006A00	8 (203)	11 (279)	16-1/2 (419)	28-3/4 (730)
	CPRFCURB007A00	14 (356)	11 (279)	16-1/2 (419)	28-3/4 (730)
50XP042-060	CPRFCURB008A00	8 (203)	16-3/16 (411)	17-3/8 (441)	40-1/4 (1022)
	CPRFCURB009A00	14 (356)	16-3/16 (411)	17-3/8 (441)	40-1/4 (1022)

NOTES:

1. Roof curb must be set up for unit being installed.
2. Seal strip must be applied, as required, to unit being installed.
3. Roof curb is made of 16-gauge steel.
4. Attach ductwork to curb (flanges of duct rest on curb).
5. Insulated panels: 1-in. (25.4 mm) thick fiberglass 1 lb. density.
6. When unit mounting screw is used (see Note A), a retainer bracket must be used as well. This bracket must also be used when required by code for hurricane or seismic conditions. This bracket is available through Micrometl.

50XP UNIT SUGGESTED RIGGING

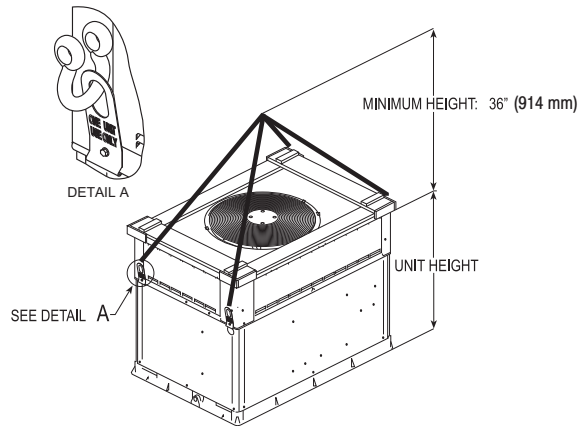
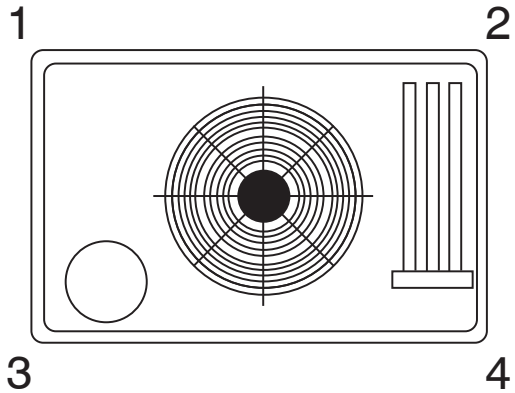

A07216

A08005

Unit*	SMALL CABINET						Unit*	LARGE CABINET					
	024 lb	024 kg	030 lb	030 kg	036 lb	036 kg		042 lb	042 kg	048 lb	048 kg	060 lb	060 kg
Rigging Weight	345	156	349	158	367	166	Rigging Weight	425	193	459	208	504	229

NOTE: See dimensional drawing for corner weight distribution. Corner weights shown on drawing are based on unit—only weights and do not include packaging.

SELECTION PROCEDURE (WITH EXAMPLE)

1. Determine cooling and heating requirements at design conditions:

Given:

Required Cooling Capacity (TC) 34,500 Btuh
 Sensible Heat Capacity (SHC) 26,000 Btuh
 Required Heating Capacity 15,000 Btuh
 Condenser Entering Air Temperature 95°F(35°C)
 Indoor-Air Temperature 80°F (26°C) edb
 67°F (19°C) ewb
 Evaporator Air Quantity 1200 CFM
 External Static Pressure 0.20 IN. W.C.
 Electrical Characteristics 230-1-60

2. Select unit based on required cooling capacity.

Enter Net Cooling Capacities table at condenser entering temperature of 95°F (35°C). The 036 unit at 1225 CFM and 67°F (19°C) ewb (entering wet bulb) will provide a total capacity of 36,500 Btuh and a SHC of 27,600 Btuh. Calculate SHC correction, if required, using Note 4 under Cooling Capacities tables.

3. Select electric heat.

The required heating capacity is 15,000 Btuh.

Determine additional electric heat capacity in kW.

$$\frac{15,000 \text{ Btuh}}{3,414 \text{ Btuh/kW}} = 4.4 \text{ kW of heat required}$$

Enter the Electric Heater Packages table for 208/240, single-phase, 036 unit. The 5 kW heater at 240v most closely satisfies the heating required. To calculate kW at the 208v, multiply the heater kW by multiplication factor 0.75 found in the Wattage Multiplication Factors table.

$$5 \text{ kW} \times 0.75 = 3.75 \text{ kW}$$

$$3.75 \text{ kW} \times 3414 = 12,802.50 \text{ Btuh}$$

4. Determine fan speed and power requirements at design conditions.

Before entering the air delivery tables, calculate the total static pressure required. From the given example, the Filter Pressure Drop Table, and the Accessory Electric Heat Pressure Drop table, find:

External Static Pressure	0.200 IN. W.C.
Filter	0.130 IN. W.C.
Wet Coil Pressure Drop	<u>0.032 IN. W.C.</u>
Total Static Pressure	0.362 IN. W.C.

Enter the table for Dry Coil Air Delivery—At 0.362 IN. W.C. ESP (external static pressure) and NOM speed pin selection, the motor will deliver 1235 cfm.

5. Select unit that corresponds to power source available.

The Electrical Data Table shows that the unit is designed to operate at 208-1-60.

50XP

PERFORMANCE DATA (CONT)

50XP036

Temp °F (°C) Outdoor Air Entering Condenser	Evaporator Air – CFM/BF														
	1100/0.06					1225/0.07					1400/0.08				
	62	63*	67	72	72	62	63*	67	72	72	62	63*	67	72	72
75 (23.9)	33.2	26.7	27.8	22.3	22.3	34.7	27.9	29.0	23.1	23.1	36.9	29.6	28.8	30.9	24.2
	2.7	2.7	2.7	2.7	2.7	2.7	2.7	2.7	2.8	2.8	2.8	2.8	2.8	2.8	2.9
85 (29.4)	34.6	35.1	37.9	41.8	41.8	35.3	35.6	38.4	42.4	42.4	36.4	36.3	39.1	36.4	43.1
	32.4	26.0	27.1	21.6	21.6	34.0	28.3	28.3	22.4	22.4	35.6	28.9	30.2	30.2	23.6
	2.9	2.9	3.0	3.0	3.0	3.0	3.0	3.0	3.0	3.0	3.1	3.1	3.1	3.1	3.2
95 (35)	33.0	33.4	36.0	39.7	39.7	33.7	33.8	36.5	40.2	40.2	34.8	34.4	37.0	37.0	40.8
	31.6	25.3	26.4	20.9	20.9	32.9	27.6	27.6	21.7	21.7	34.4	28.1	29.4	29.4	22.8
	3.2	3.2	3.3	3.3	3.3	3.3	3.3	3.3	3.4	3.4	3.4	3.4	3.4	3.4	3.5
105 (104.6)	31.3	31.5	34.0	37.5	37.5	32.1	31.9	34.3	37.9	37.9	33.1	32.4	34.9	34.9	38.4
	30.6	24.5	25.6	20.1	20.1	31.5	25.7	26.8	20.9	20.9	32.8	27.3	28.6	28.6	22.0
	3.6	3.6	3.6	3.6	3.6	3.6	3.6	3.7	3.7	3.7	3.8	3.7	3.8	3.8	3.8
115 (46.1)	29.6	29.4	31.8	35.0	35.0	30.4	29.8	32.1	35.4	35.4	31.3	30.3	32.6	32.6	35.8
	29.3	23.7	24.8	19.3	19.3	30.0	24.8	26.0	20.0	20.0	31.0	26.4	27.7	27.7	21.1
	4.0	4.0	4.0	4.0	4.0	4.0	4.0	4.0	4.0	4.0	4.1	4.1	4.1	4.1	4.2
125 (51.7)	27.8	27.2	29.4	32.4	32.4	28.4	27.5	29.7	32.7	32.7	29.3	28.0	30.1	30.1	33.0
	27.5	22.8	23.9	18.4	18.4	28.2	23.8	25.0	19.1	19.1	29.0	25.4	26.7	26.7	20.2
	4.4	4.3	4.4	4.4	4.4	4.4	4.4	4.4	4.4	4.4	4.5	4.5	4.5	4.5	4.5

50XP042

Temp °F (°C) Outdoor Air Entering Condenser	Evaporator Air – CFM/BF														
	1225/0.06					1400/0.07					1575/0.08				
	62	63*	67	72	72	62	63*	67	72	72	62	63*	67	72	72
75 (23.9)	39.6	40.4	43.4	47.6	47.6	40.5	41.2	44.2	48.4	48.4	41.5	42.1	45.1	45.1	49.4
	33.5	27.6	28.6	23.4	23.4	35.4	29.0	30.0	24.3	24.3	37.9	30.8	31.9	31.9	25.6
	3.0	3.0	3.0	3.1	3.1	3.0	3.0	3.0	3.1	3.1	3.0	3.0	3.0	3.0	3.1
85 (29.4)	37.9	38.7	41.5	45.5	45.5	38.7	39.4	42.3	46.3	46.3	39.7	40.2	43.2	43.2	47.2
	32.8	26.9	27.8	22.7	22.7	34.6	28.2	29.2	23.6	23.6	37.0	30.0	31.1	31.1	24.8
	3.3	3.3	3.4	3.4	3.4	3.3	3.3	3.4	3.4	3.4	3.3	3.3	3.4	3.4	3.4
95 (35)	36.2	36.8	39.6	43.4	43.4	36.9	37.5	40.3	44.1	44.1	37.8	38.2	41.0	41.0	44.9
	32.0	26.1	27.0	21.9	21.9	33.8	27.4	28.4	22.8	22.8	35.9	29.1	30.3	30.3	24.0
	3.7	3.7	3.7	3.8	3.8	3.7	3.7	3.7	3.8	3.8	3.7	3.7	3.7	3.7	3.8
105 (104.6)	34.2	34.8	37.4	41.0	41.0	34.9	35.4	38.0	41.6	41.6	36.0	36.0	38.7	38.7	42.3
	31.0	25.2	26.2	21.1	21.1	32.7	26.5	27.6	22.0	22.0	34.3	28.3	29.4	29.4	23.2
	4.1	4.1	4.1	4.1	4.1	4.1	4.1	4.1	4.1	4.1	4.1	4.1	4.1	4.1	4.1
115 (46.1)	32.1	32.6	35.0	38.4	38.4	32.8	33.1	35.5	39.5	39.5	34.0	33.7	36.1	36.1	39.5
	30.0	24.3	25.2	20.2	20.2	31.4	25.6	26.6	21.0	21.0	32.8	27.3	28.5	28.5	22.2
	4.5	4.5	4.5	4.5	4.5	4.5	4.5	4.5	4.6	4.6	4.5	4.5	4.5	4.5	4.6
125 (51.7)	29.8	30.1	32.3	35.3	35.3	30.6	30.5	32.7	35.7	35.7	31.7	31.0	33.2	33.2	36.2
	28.6	23.2	24.2	19.1	19.1	29.6	24.5	25.5	20.0	20.0	30.6	26.1	27.3	27.3	21.1
	4.9	4.9	4.9	5.0	5.0	4.9	4.9	4.9	4.9	4.9	4.9	4.9	4.9	4.9	5.0

See Legend and Notes on Page 15.

PERFORMANCE DATA (CONT)

50XP048

Temp °F (°C) Outdoor Air Entering Condenser	Evaporator Air – CFM/BF											
	1260/0.06				1400/0.06				1600/0.08			
	62	63*	67	72	62	63*	67	72	62	63*	67	72
75 (23.9)	16.7	17.2	19.4	22.2	16.7	17.2	19.4	22.2	19.7	17.2	19.4	22.2
SHC	45.8	45.8	49.6	54.7	46.7	47.3	51.2	56.3	48.1	48.7	52.5	57.8
KW	3.4	3.4	3.4	3.4	3.4	3.4	3.4	3.5	3.4	3.4	3.4	3.5
85 (29.4)	38.2	30.9	32.3	26.2	41.3	33.2	34.7	27.7	44.3	35.5	37.3	29.4
TC	42.8	43.6	47.2	52.1	44.3	44.9	48.6	53.5	45.6	46.1	49.9	54.8
KW	3.7	3.7	3.8	3.8	3.7	3.7	3.8	3.8	3.8	3.8	3.8	3.8
95 (35)	40.6	41.3	44.7	49.4	41.8	42.4	46.0	50.7	44.2	43.7	47.0	51.8
SHC	36.9	29.8	31.2	25.2	39.9	32.0	36.1	34.6	43.0	34.6	41.2	48.5
KW	4.1	4.1	4.2	4.2	4.1	4.1	4.2	4.2	4.2	4.1	4.2	4.2
105 (104.6)	38.2	38.9	42.1	48.4	39.6	39.8	43.1	47.6	41.5	40.8	44.0	48.5
SHC	35.7	28.7	30.1	24.0	38.3	30.7	32.3	25.5	40.0	33.2	34.8	27.0
KW	4.6	4.6	4.6	4.6	4.6	4.6	4.6	4.7	4.6	4.6	4.6	4.7
115 (46.1)	35.7	36.3	39.3	43.3	38.2	37.1	40.1	44.2	38.7	37.9	40.8	45.0
SHC	34.4	27.5	28.9	22.9	35.7	29.5	31.0	24.3	36.2	31.8	33.5	25.8
KW	5.0	5.0	5.1	5.1	5.1	5.1	5.1	5.1	5.1	5.1	5.1	5.1
125 (51.7)	33.4	33.4	36.2	39.4	34.6	34.1	36.9	40.5	36.1	34.8	37.5	41.2
SHC	32.1	26.2	27.6	21.5	33.8	28.2	29.7	22.9	35.6	30.2	31.9	24.4
KW	5.6	5.6	5.6	5.7	5.6	5.6	5.6	5.6	5.6	5.6	5.6	5.6

50XP060

Temp °F (°C) Outdoor Air Entering Condenser	Evaporator Air – CFM/BF											
	1500/0.04				1750/0.07				2000/0.01			
	62	63*	67	72	62	63*	67	72	62	63*	67	72
75 (23.9)	16.7	17.2	19.4	22.2	16.7	17.2	19.4	22.2	19.7	17.2	19.4	22.2
SHC	49.4	47.9	41.6	33.8	53.6	51.8	44.5	35.4	57.6	55.4	47.1	36.8
KW	4.1	4.1	4.2	4.2	4.2	4.3	4.3	4.4	4.4	4.4	4.5	4.6
85 (29.4)	54.7	55.6	59.7	65.2	56.2	57.0	61.1	66.6	57.4	58.1	61.9	67.4
SHC	48.2	46.7	40.4	32.6	52.4	50.5	43.2	34.2	56.3	54.2	45.8	35.6
KW	4.5	4.5	4.6	4.7	4.7	4.7	4.8	4.9	4.8	4.9	5.0	5.0
95 (35)	47.0	45.4	39.2	31.4	51.1	49.2	41.9	32.9	55.0	52.9	44.5	34.4
SHC	5.0	5.0	5.1	5.2	5.1	5.2	5.3	5.3	5.3	5.3	5.5	5.5
KW	49.4	50.2	53.8	58.7	50.7	51.4	54.8	59.6	52.5	52.4	55.4	60.2
SHC	45.7	44.1	37.9	30.1	49.8	47.9	40.6	31.6	52.5	51.6	43.2	33.0
KW	5.5	5.6	5.6	5.7	5.7	5.7	5.8	5.9	5.8	5.8	6.0	6.1
115 (46.1)	46.5	47.2	50.5	55.0	48.1	48.3	51.3	56.8	49.7	49.7	51.8	57.0
SHC	44.3	42.7	36.4	28.7	48.1	46.6	39.2	30.6	49.7	49.7	41.8	31.7
KW	6.1	6.2	6.2	6.3	6.2	6.3	6.4	6.4	6.4	6.4	6.6	6.6
125 (51.7)	43.8	43.9	46.7	52.2	45.2	45.1	47.4	52.5	46.4	46.4	47.9	52.2
SHC	42.8	41.2	34.9	27.8	45.2	45.1	37.6	28.9	46.4	46.4	40.2	29.7
KW	6.7	6.8	6.8	6.8	6.8	6.9	7.0	7.0	7.0	7.0	7.2	7.2

See Legend and Notes on Page 15.

PERFORMANCE DATA (CONT)

* At 75°F (24°C) entering dry bulb – Tennessee Valley Authority (TVA) rating conditions; all others at 80°F (27°C) dry bulb.

LEGEND

BF—Bypass Factor
 edb—Entering Dry—Bulb
 Ewb—Entering Wet—Bulb
 kW—Total Unit Power Input
 SHC—Sensible Heat Capacity (1000 Btuh)
 TC—Total Capacity (1000 Btuh) (net)
 rh—Relative Humidity

COOLING NOTES:

1. Ratings are net; they account for the effects of the evaporator—fan motor power and heat.
2. Direct interpolation is permissible. Do not extrapolate.
3. The following formulas may be used:

$$t_{ldb} = t_{edb} - \frac{\text{Sensible capacity (Btuh)}}{1.10 \times \text{cfm}}$$

$$t_{lwb} = \frac{\text{Wet-bulb temperature corresponding to enthalpy of air leaving evaporator coil (} t_{lwb} \text{)}}{\frac{\text{total capacity (Btuh)}}{4.5 \times \text{cfm}}}$$

Where: t_{lwb} = Enthalpy of air entering evaporator coil

4. The SHC is based on 805 F (26.6°C) edb temperature of air entering evaporator coil. Below 80°F (26.6°C) edb, subtract (corr factor x cfm) from SHC. Above 80°F (26.6°C) edb, add (corr factor x cfm) to SHC.

Correction Factor = $1.10 \times (1 + BF) \times (edb + 80)$.

5. Integrated capacity is maximum (instantaneous) capacity less the effect of frost on the outdoor coil and the heat required to defrost it.

PERFORMANCE DATA (CONT)

Economizer 1-in. Filter Pressure Drop (IN. W.C.)

UNIT50XP	PRESSURE DROP
024-036	0.20
042-060	0.25

Multiplication Factors

HEATER KW RATING	VOLTAGE DISTRIBUTION V/3/60	MULTIPLICATION FACTOR
240	200	0.69
	208	0.75
	230	0.92
	240	1.00

Filter Pressure Drop Table (IN. W.C.)

FILTER SIZE in. (mm)	CFM																		
	500	600	700	800	900	1000	1100	1200	1300	1400	1500	1600	1700	1800	1900	2000	2100	2200	2300
20X20X1 (508X508X25)	0.05	0.07	0.08	0.10	0.12	0.13	0.14	0.15	—	—	—	—	—	—	—	—	—	—	—
20X24X1 (508X610x25)	—	—	—	—	0.09	0.10	0.11	0.13	0.14	0.15	0.16	—	—	—	—	—	—	—	—
24X30X1 (610X762x25)	—	—	—	—	—	—	—	0.07	0.08	0.09	0.10	0.11	0.12	0.13	0.14	0.15	0.16	0.17	0.18

Electric Heat Pressure Drop Tables (IN. W.C.)

Small Cabinet: 024-036

STATIC	CFM												
	500	600	700	800	900	1000	1100	1200	1300	1400	1500	1600	
5 kW	0.00	0.00	0.00	0.00	0.00	0.00	0.00	0.00	0.02	0.04	0.06	0.07	
7.5 kW	0.00	0.00	0.00	0.00	0.00	0.00	0.00	0.02	0.03	0.05	0.07	0.08	
10 kW	0.00	0.00	0.00	0.00	0.00	0.00	0.02	0.04	0.06	0.07	0.09	0.10	
15 kW	0.00	0.00	0.00	0.02	0.04	0.06	0.08	0.10	0.12	0.14	0.16	0.18	

Large Cabinet: 042-060

STATIC	CFM														
	1100	1200	1300	1400	1500	1600	1700	1800	1900	2000	2100	2200	2300	2400	2500
5 kW	0.00	0.00	0.00	0.01	0.02	0.03	0.04	0.05	0.06	0.07	0.08	0.09	0.10	0.11	0.12
7.5 kW	0.00	0.00	0.01	0.02	0.03	0.04	0.05	0.06	0.07	0.08	0.09	0.10	0.11	0.12	0.13
10 kW	0.00	0.00	0.01	0.02	0.03	0.04	0.05	0.06	0.07	0.08	0.09	0.10	0.11	0.12	0.13
15 kW	0.00	0.02	0.03	0.04	0.05	0.06	0.07	0.08	0.09	0.10	0.11	0.12	0.13	0.14	0.15
20 kW	0.02	0.03	0.04	0.05	0.06	0.07	0.08	0.09	0.10	0.11	0.12	0.13	0.14	0.15	0.16

ECM Dry Coil Airflow-Small Cabinet

UNIT SIZE	CFM ADJUST PIN SELECT	LO PIN			NOM PIN			HI PIN		
	EXTERNAL STATIC PRESSURE RANGE	0.0-0.39	0.4-0.69	0.7-1.0	0.0-0.39	0.4-0.69	0.7-1.0	0.0-0.39	0.4-0.69	0.7-1.0
024	COOLING	800	725	-	885	805	730	990	930	855
	COOLING DEHUMIDIFY	715	670	-	715	695	645	795	775	745
030	COOLING	1010	920	825	1105	1030	930	1255	1160	1050
	COOLING DEHUMIDIFY	890	845	795	890	865	825	1010	980	925
036	COOLING	1110	1025	970	1235	1175	1115	1400	1355	1280
	COOLING DEHUMIDIFY	990	960	910	990	975	940	1125	1110	1085

ECM Dry Coil Airflow-Large Cabinet

UNIT SIZE	CFM ADJUST PIN SELECT	LO PIN	NOM PIN	NOM PIN
	EXTERNAL STATIC PRESSURE RANGE	0.1-1.0	0.1-1.0	0.1-1.0
042	COOLING	1100	1225	1410
	COOLING DEHUMIDIFY	980	980	1125
048	COOLING	1260	1400	1610
	COOLING DEHUMIDIFY	1120	1120	1290
060	COOLING	1575	1750	2010
	COOLING DEHUMIDIFY	1400	1400	1610

Wet Coil Pressure Drop (IN. W.C.)

Unit Size	Standard CFM (S.C.F.M)															
	600	700	800	900	1000	1100	1200	1300	1400	1500	1600	1700	1800	1900	2000	2100
024	0.005	0.007	0.010	0.012	0.015											
030		0.007	0.010	0.012	0.015	0.018	0.021	0.024								
036			0.019	0.023	0.027	0.032	0.037	0.042	0.047							
042				0.014	0.017	0.020	0.024	0.027	0.031	0.035	0.039	0.043				
048						0.027	0.032	0.036	0.041	0.046	0.052	0.057	0.063	0.068		
060									0.029	0.032	0.036	0.040	0.045	0.049	0.053	

TYPICAL PIPING AND WIRING

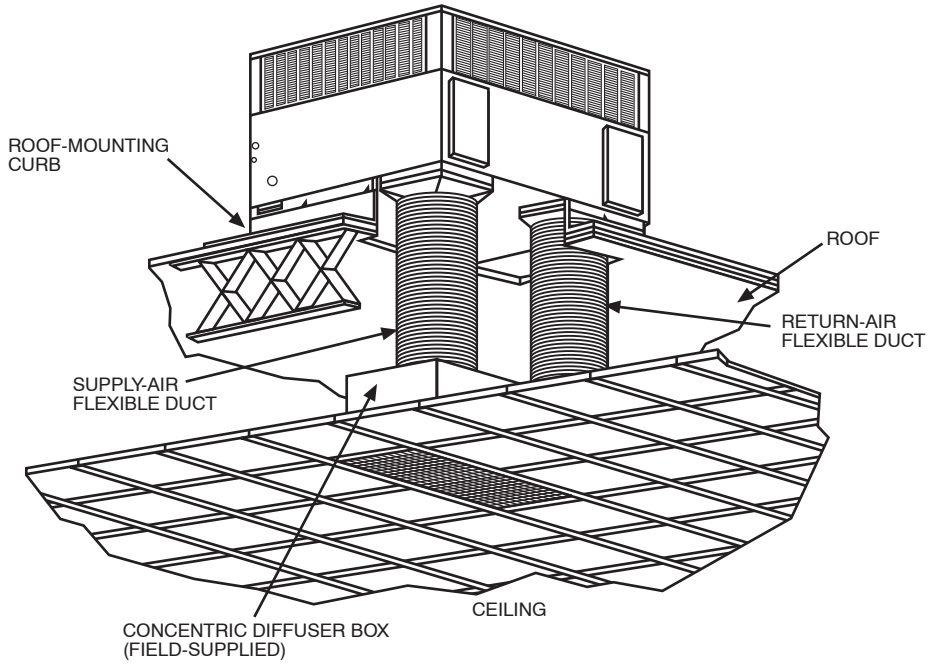

C00023

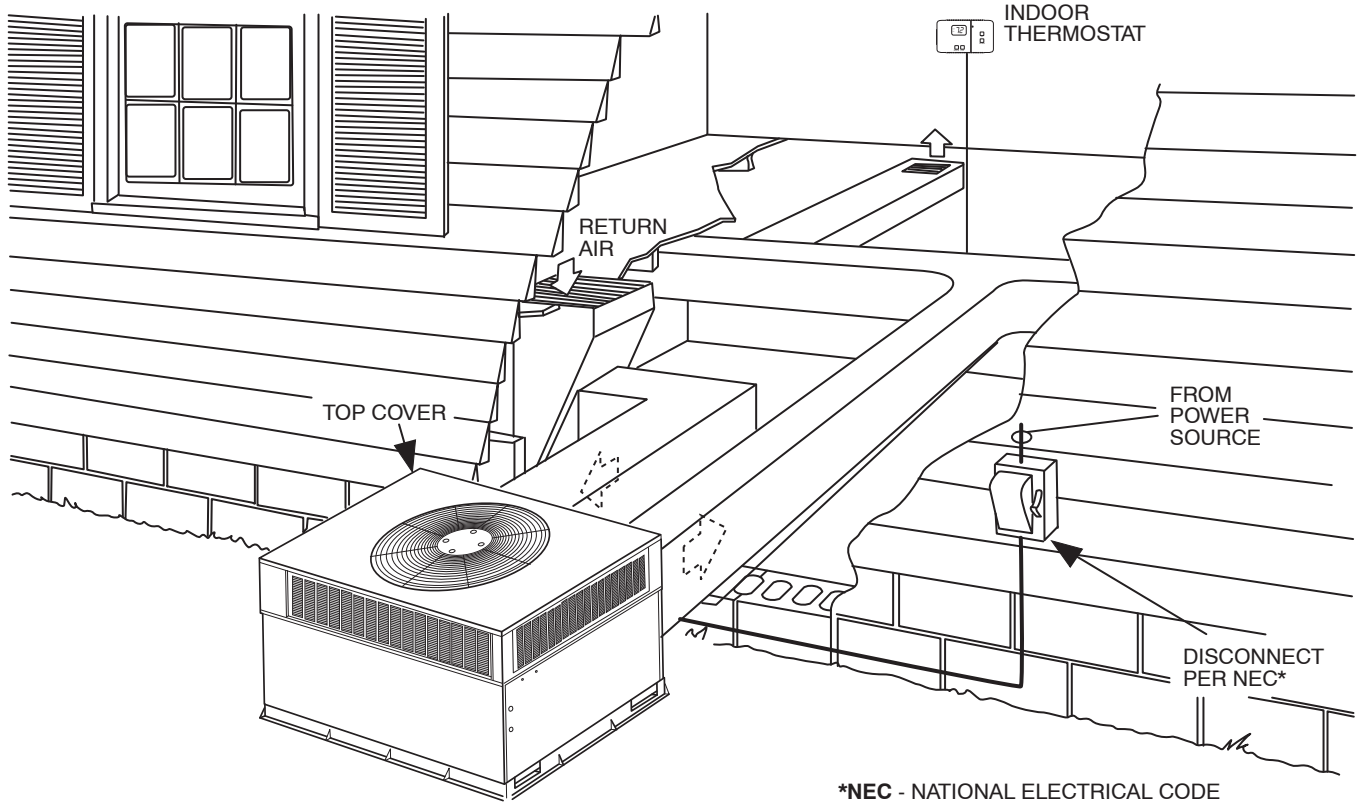

C00063

50XP

APPLICATION DATA

Condensate trap — A 2-in. (51 mm) condensate trap must be field supplied.

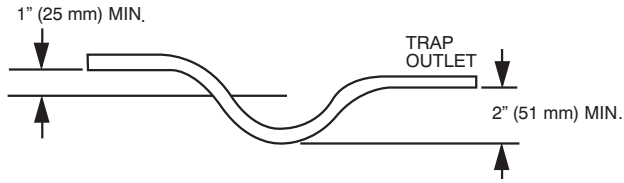

A08001

Ductwork — Secure downflow discharge ductwork to roof curb. For horizontal discharge applications, attach ductwork to unit with flanges.

To convert a unit to downflow discharge — Units are equipped with factory-installed inserts in the downflow openings. Removal of the inserts is similar to removing an electrical knock-out. Leave on duct covers to seal the horizontal discharge openings in the unit. Units installed in horizontal discharge orientation do not require duct covers.

Maximum cooling airflow — To minimize the possibility of condensate blow-off from the evaporator, airflow through the units should not exceed 450 cfm per ton.

Minimum cooling airflow — Minimum cooling airflow is 350 cfm per ton for standard cooling modes. Airflow can be lower in certain modes when humidity removal is an issue.

Minimum cooling operating outdoor air temperature — All standard units have a minimum outdoor operating temperature of 55°F (13°C). With accessory low ambient temperature kit, units can operate at temperatures down to 0°F (-17°C).

Maximum cooling operating outdoor air temperature — Maximum outdoor operating air temperature is 125°F (52°C).

ELECTRICAL DATA

UNIT	NOMINAL V-PH-HZ	VOLTAGE RANGE		COMPRESSOR		OFM	IFM	ELECTRIC HEAT		POWER SUPPLY		
		MIN	MAX	RLA	LRA	FLA	FLA	NOMINAL KW	FLA	MCA	MAX FUSE or CKT BKR	MOCP
50XP-024	208/230-1-60	187	253	13.5	61.0	0.8	4.3	-/-	-/-	22.0/22.0	30/30	-
								3.8/5	18.1/20.8	27.9/31.4	30/35	-
								5.4/7.2	26/30	37.9/42.9	40/45	-
								7.5/10	36.1/41.7	50.5/57.5	60/60	-
								-/-	-/-	23.6/23.6	30/30	-
50XP-030	208/230-1-60	187	253	15.9	73.0	0.8	4.3	3.8/5	18.1/20.8	27.9/31.4	30/35	-
								5.4/7.2	26/30	37.9/42.9	40/45	-
								7.5/10	36.1/41.7	50.5/57.5	60/60	-
								11.3/15	54.2/62.5	73.1/83.5	-	80/90
								-/-	-/-	26.9/26.9	35/35	-
50XP-036	208/230-1-60	187	253	16.9	83.0	0.8	6.8	3.8/5	18.1/20.8	31.1/34.5	35/35	-
								5.4/7.2	26/30	41.0/46.0	45/50	-
								7.5/10	36.1/41.7	53.6/60.6	-	60/70
								11.3/15	54.2/62.5	76.2/86.6	-	80/90
								-/-	-/-	23.0/23.0	30/30	-
	208/230-3-60	187	253	12.2	77.0	0.8	6.8	5	10.4/12	23.0/23.5	30/30	-
								10	20.8/24.1	34.6/38.6	35/35	-
								15	31.3/36.1	47.6/53.6	50/60	-
								-/-	-/-	30.9/30.9	45/45	-
								-/-	-/-	31.1/34.5	45/45	-
50XP-042	208/230-1-60	187	253	22.4	105.0	0.8	6.8	3.8/5	18.1/20.8	31.1/34.5	45/45	-
								5.4/7.2	26/30	41.0/46.0	45/50	-
								7.5/10	36.1/41.7	53.6/60.6	-	60/70
								11.3/15	54.2/62.5	76.2/86.6	-	80/90
								15/20	72.2/83.3	98.8/112.7	-	100/125
	208/230-3-60	187	253	15.4	88.0	0.8	6.8	3.8/5	10.4/12	27.0/27.0	35/35	-
								7.5/10	20.8/24.1	34.6/38.6	35/35	-
								11.3/15	31.3/36.1	47.6/53.6	50/60	-
								15/20	41.6/48	60.5/68.5	-	70/70
								-/-	-/-	33.9/33.9	45/45	-
50XP-048	208/230-1-60	187	253	21.3	109.0	1.6	6.8	3.8/5	18.1/20.8	33.9/34.5	45/45	-
								5.4/7.2	26/30	41.0/46.0	45/50	-
								7.5/10	36.1/41.7	53.6/60.6	-	60/70
								11.3/15	54.2/62.5	76.2/86.6	-	80/90
								15/20	72.2/83.3	98.8/112.7	-	100/125
	208/230-3-60	187	253	14.7	91.0	1.6	6.8	3.8/5	10.4/12	26.7/26.7	35/35	-
								7.5/10	20.8/24.1	34.6/38.6	35/35	-
								11.3/15	31.3/36.1	47.6/53.6	50/60	-
								15/20	41.6/48	60.5/68.5	-	70/70
								-/-	-/-	26.7/26.7	35/35	-
50XP-060	208/230-1-60	187	253	27.0	145.0	1.6	9.1	3.8/5	18.1/20.8	44.3/44.3	60/60	-
								5.4/7.2	26/30	44.3/48.9	60/60	-
								7.5/10	36.1/41.7	56.5/63.5	-	60/70
								11.3/15	54.2/62.5	79.1/89.5	-	80/90
								15/20	72.2/83.3	101.6/115.5	-	100/125
	208/230-3-60	187	253	19.2	137.0	1.6	9.1	3.8/5	10.4/12	33.0/33.0	40/40	-
								7.5/10	20.8/24.1	37.4/41.4	40/45	-
								11.3/15	31.3/36.1	50.5/56.5	60/60	-
								15/20	41.6/48	63.3/71.3	-	70/80
								-/-	-/-	44.3/44.3	60/60	-

50XP

LEGEND

- FLA -- Full Load Amps
- LRA -- Locked Rotor Amps
- MCA -- Minimum Circuit Amps
- MOCP -- Maximum Overcurrent Protection
- RLA -- Rated Load Amps

*Heater capacity (kW) based on heater voltage of 208v, 240v, & 480v. If power distribution voltage to unit varies from rated heater voltage, heater kW will vary accordingly.

NOTES:

- In compliance with NEC (National Electrical Code) requirements for multimotor and combination load equipment (refer to NEC Articles 430 and 440), the overcurrent protective device for the unit shall be Power Supply fuse. The CGA (Canadian Gas Association) units may be fuse or circuit breaker.
- Minimum wire size is based on 60 C copper wire. If other than 60 C wire is used, or if length exceeds wire length in table, determine size from NEC.
- Unbalanced 3-Phase Supply Voltage
Never operate a motor where a phase imbalance in supply voltage is greater than 2%. Use the following formula to determine the percentage of voltage imbalance

$$\% \text{ Voltage imbalance} = 100 \times \frac{\text{max voltage deviation from average voltage}}{\text{average voltage}}$$

EXAMPLE: Supply voltage is 460-3-60.

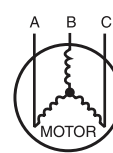

$$\begin{aligned} AB &= 452 \text{ v} \\ BC &= 464 \text{ v} \\ AC &= 455 \text{ v} \\ \text{Average Voltage} &= \frac{452 + 464 + 455}{3} \\ &= \frac{1371}{3} \\ &= 457 \end{aligned}$$

Determine maximum deviation from average voltage.

- (AB) 457 - 452 = 5 v
- (BC) 464 - 457 = 7 v
- (AC) 457 - 455 = 2 v

Maximum deviation is 7 v.

Determine percent of voltage imbalance

$$\begin{aligned} \% \text{ Voltage Imbalance} &= 100 \times \frac{7}{457} \\ &= 1.53\% \end{aligned}$$

This amount of phase imbalance is satisfactory as it is below the maximum allowable 2%.

IMPORTANT: If the supply voltage phase imbalance is more than 2%, contact your local electric utility company immediately.

TYPICAL WIRING SCHEMATIC 208/230-1-60

50XP

SCHEMATIC
208/230-1-60

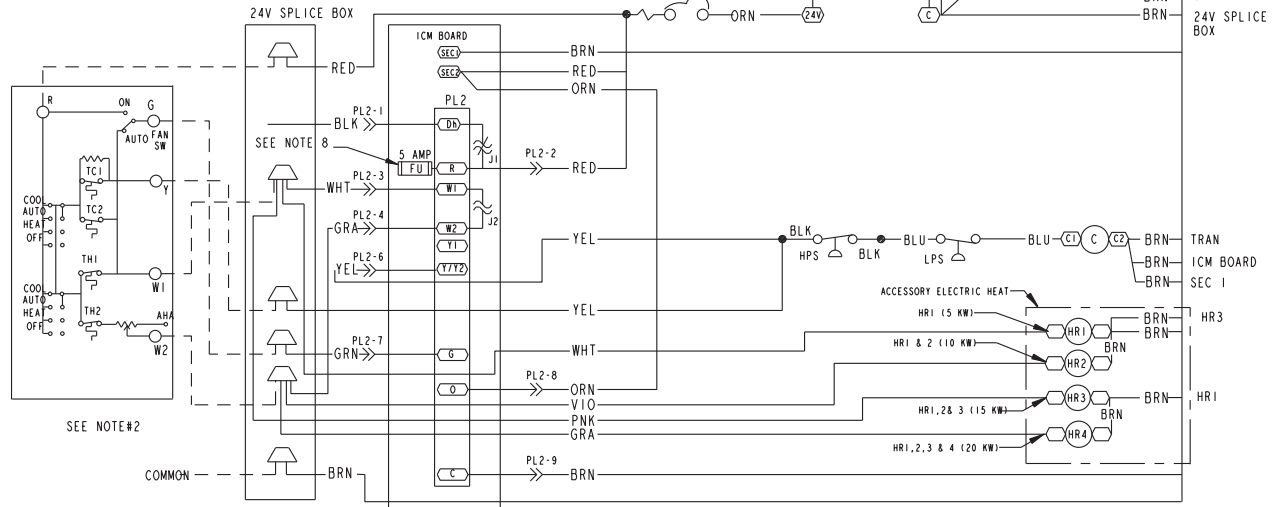
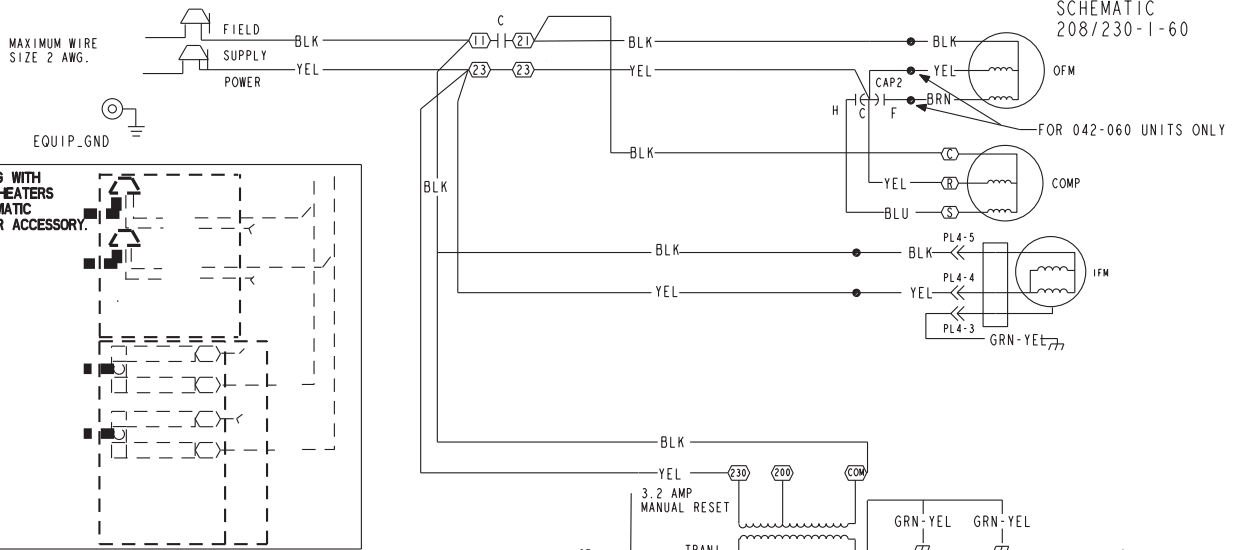

- ### LEGEND
- △ FIELD SPLICE
 - TERMINAL (MARKED)
 - TERMINAL (UNMARKED)
 - SPLICE
 - SPLICE (MARKED)
 - FACTORY WIRING
 - - - FIELD CONTROL WIRING
 - - - FIELD POWER WIRING
 - - - ACCESSORY OR OPTIONAL WIRING
 - - - TO INDICATE COMMON POTENTIAL ONLY; NOT TO REPRESENT WIRING
 - AHA ADJUSTABLE HEAT ANTICIPATOR
 - C CAPACITOR
 - CB CIRCUIT BREAKER
 - COMP COMPRESSOR MOTOR
 - EQ EQUIPMENT
 - FU FUSE
 - GND GROUND
 - HPS HIGH PRESSURE SWITCH
 - HR HEATER RELAY
 - HTR HEATER
 - ICM INTEGRATED CONTROL MOTOR
 - IFM INDOOR FAN MOTOR
 - TDR TIME DELAY RELAY
 - LPS LOW PRESSURE SWITCH
 - OFM OUTDOOR FAN MOTOR
 - SW SWITCH
 - S.B. SLOW BLOW FUSE - COOLING
 - TC THERMOSTAT - COOLING
 - TH THERMOSTAT - HEATING
 - TRAN TRANSFORMER

- ### NOTES:
- IF ANY OF THE ORIGINAL WIRES FURNISHED ARE REPLACED, IT MUST BE REPLACED WITH TYPE 90 DEGREE C WIRE OR IT'S EQUIVALENT.
 - SEE PRICE PAGES FOR THERMOSTAT AND SUBBASES.
 - USE 75 DEGREE COPPER CONDUCTORS FOR FIELD INSTALLATION.
 - REPLACE LOW VOLTAGE FUSE WITH NO GREATER THAN 5 AMP FUSE.
 - TO BE WIRED IN ACCORDANCE WITH NEC AND LOCAL CODES.
 - REMOVE J1 WHEN USING THERMIDISTAT/HUMIDISTAT AND DEHUMIDIFICATION MODES.
 - REMOVE J2 WHEN USING MORE THAN ONE STAGE OF ELECTRIC HEAT.
 - THIS FUSE IS MANUFACTURED BY LITTELFUSE, P/N 257005.

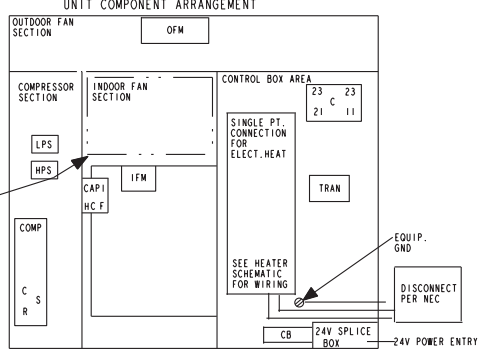
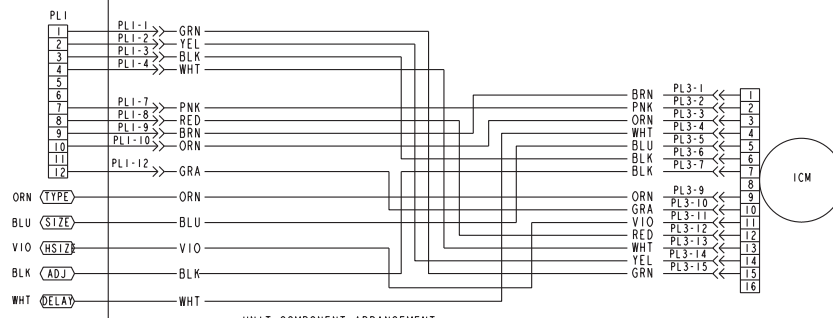

50GL500043 | 8.0

A08460

CONTROLS

Operating sequence

Cooling — When the system thermostat calls for cooling, 24 V is supplied to the “Y” and “G” terminals of the thermostat. This completes the circuit to the contactor coil (C) and indoor fan board. The normally open contacts of C close and complete the circuit to compressor motor (COMP) and to outdoor (condenser) fan motor (OFM). Both motors start instantly. The IFM starts according to the selection pin set-up on the Easy Select Board.

On the loss of the thermostat call for cooling, 24 V is removed from both the “Y” and “G” terminals (provided the fan switch is in the “AUTO” position) de-energizing the compressor contactor and opening the contacts supplying power to compressor/OFM. After a preselected delay, the IFM shuts off. If the thermostat fan selector switch is in the “ON” position, the IFM will run continuously at speed selected on Easy Select Board

Heating — If accessory electric heaters are installed, on a call for heat, circuit R-W is made through the thermostat contacts. Circuit R-G is made which energizes the IFM. If the heaters are staged, then the thermostat closes a second set of contacts (W2) when second stage is required. When thermostat is satisfied, contacts open, deenergizing the heater relay. After a preselected delay, the IFM shuts off. If the thermostat fan selector switch is in the “ON” position, the IFM will run continuously at speed selected on Easy Select Board.

NOTE: On units with a Time Guard® II device: Once the compressor has started and then stopped, it cannot be restarted again until 5 minutes have elapsed.

The indoor blower operation with a call for fan operation (G) in cooling mode will perform by the on/off delay profile selected at start up on the Easy Select Board.

GUIDE SPECIFICATIONS

Packaged Electric Cooling Unit Constant Volume Application HVAC Guide Specifications

Size Range: **2 to 5 Tons, Nominal Cooling**

Model Number: 50XP

Part 1 — General

SYSTEM DESCRIPTION

Outdoor rooftop mounted or ground mounted, electric cooling unit utilizing a hermetic compressor for cooling duty and optional electric heating. Unit shall discharge supply air vertically or horizontally as shown on contract drawings. Condenser fan/coil section shall have a draw-thru design with vertical discharge for minimum sound levels.

QUALITY ASSURANCE

- A. Unit shall be rated in accordance with ARI Standards 210/240 and 270.**
- B. Unit shall be designed in accordance with UL Standard 1995.**
- C. Unit shall be manufactured in a facility registered to ISO 9001 manufacturing quality standard.**
- D. Unit shall be UL listed and c-UL certified as a total package for safety requirements.**
- E. Roof curb shall be designed to conform to NRCA Standards.**
- F. Insulation and adhesives shall meet NFPA 90A requirements for flame spread and smoke generation.**
- G. Cabinet insulation shall meet ASHRAE Standard 62P.**

DELIVERY, STORAGE AND HANDLING

Unit shall be stored and handled per manufacturer's recommendations.

Part 2 — Products

EQUIPMENT

A. General:

Factory-assembled, single-piece, cooling unit. Contained within the enclosure shall be all factory wiring, piping, controls, refrigerant charge with R-410A refrigerant, and special features required prior to field start-up.

B. Unit Cabinet:

- 1. Unit cabinet shall be constructed of phosphated, zinc-coated, pre-painted steel capable of with-standing 500 hours in salt spray.
- 2. Normal service shall be through a single removable cabinet panel.
- 3. The unit shall be constructed on a rust proof unit base that has an externally trapped, integrated sloped drain pan.
- 4. Evaporator fan compartment top surface shall be insulated with a minimum 1/2-in. (13 mm) thick, flexible fiberglass insulation, coated on the air side and retained by adhesive and mechanical means. The evaporator wall sections will be insulated with a minimum semi-rigid foil-faced board capable of being wiped clean. Aluminum foil-faced fiberglass insulation shall be used in the entire indoor air cavity section.
- 5. Unit shall have a field-supplied condensate trap.

C. Fans:

- 1. The evaporator fan shall be direct-drive variable speed motor and control, as shown on equipment drawings.
- 2. Fan wheel shall be made from steel, be double-inlet type with forward curved blades with corrosion resistant finish. Fan wheel shall be dynamically balanced.
- 3. Condenser fan shall be direct drive propeller type with aluminum blades riveted to corrosion resistant steel spiders, be dynamically balanced, and discharge air vertically.

D. Compressor:

- 1. Fully hermetic compressors with factory-installed vibration isolation.
- 2. Scroll compressors shall be standard on all units.

E. Coils:

Evaporator and condenser coils shall have aluminum plate fins mechanically bonded to seamless copper tubes with all joints brazed. (Copper/copper and vinyl-coated construction available as option). Tube sheet openings shall be belled to prevent tube wear.

F. Refrigerant Components:

Refrigerant expansion device shall be of the TXV (thermostatic expansion valve) type.

G. Filters:

Filter section shall consist of field-installed, throwaway, 1-in. (25 mm) thick fiberglass filters of commercially available sizes.

H. Controls and Safeties:

- 1. Unit controls shall be complete with a self-contained low voltage control circuit.
- 2. Units shall incorporate an internal compressor protector that provides reset capability.
- 3. Unit shall provide High and Low/Loss-of-Charge Pressure Safety Protection.

I. Operating Characteristics:

- 1. Unit shall be capable of starting and running at 125°F (51°C) ambient outdoor temperature,exceeding maximum load criteria of ARI Standard 210.
- 2. Compressor with standard controls shall be capable of operation down to 55°F (13°C) ambient outdoor temperature.
- 3. Indoor Fan on/off delay profile is selected (for cooling) on the Easy Select board.

J. Electrical Requirements:

All unit power wiring shall enter the unit cabinet at a single location.

K. Motors:

- 1. Compressor motors shall be of the refrigerant-cooled type with line-break thermal and current overload protection.
- 2. All fan motors shall have permanently lubricated bearings, and inherent, automatic reset, thermal overload protection.
- 3. Condenser fan motor shall be totally enclosed.

L. Grille:

- 1. Louvered Grille:
Louvered grille shall be standard on all units.

GUIDE SPECIFICATIONS (CONT)

M. Special Features:

1. Coil Options:
Shall include factory-installed optional tin-plated indoor, copper/copper and vinyl-coated refrigerant coils.
2. Economizer:
 - a. Economizer controls capable of providing free cooling using outside air.
 - b. Equipped with low leakage dampers not to exceed 3% leakage, at 1.0 IN. W.C. pressure differential.
 - c. Spring return motor shuts off outdoor damper on power failure.
3. Flat Roof Curb:
Curbs shall have seal strip and a wood nailer for flashing and shall be installed per manufacturer's instructions.
4. Manual Outdoor Air Damper:
Package shall consist of damper, birdscreen, and rainhood which can be preset to admit outdoor air for year-round ventilation.
5. Thermostat:
To provide for one-stage heating and cooling in addition manual or automatic changeover and indoor fan control.
6. Low Ambient Package:
Shall consist of a solid-state control and condenser coil temperature sensor for controlling condenser-fan motor operation, which shall allow unit to operate down to 0°F (-18°C) outdoor ambient temperature when properly installed.
7. Filter Rack Kit:
Shall provide filter mounting for downflow or horizontal applications.
8. Square-To-Round Duct Transitions (024-048):
Shall have the ability to convert the supply and return openings from rectangular to round. (024-048 only)
9. Compressor Protection:
Solid-state control shall protect compressor by preventing "short cycling."
10. Crankcase Heater:
Shall provide anti-floodback protection for low-load cooling applications.
11. Electric Heaters:
 - a. Electric heater shall be available as a field-installed option.
 - b. Heater elements shall be open wire type, adequately supported and insulated with ceramic bushings.
 - c. Electric heater packages must provide single point power connection capability.
12. Compressor Start Kit (single phase units only):
Shall provide additional starting torque for single-phase compressors.