



# Operating Instructions

## **PSW-2**

*Self-Powered Subwoofer*

*Patents Pending*



## Contents

Introduction .....	3	Measurement and System Integration Tools .....	8
AC Power .....	3	Full-Range Systems .....	8
Audio Input .....	5	Driver Troubleshooting.....	10
Amplification and Protection Circuitry .....	5	Safety Summary.....	11
Rigging .....	7	Controls and Connectors .....	12
Configuration, Placement, and Polarity.....	7	Dimensions .....	12

## Symbols Used

These symbols indicate important safety or operating features in this booklet and on the chassis.



Dangerous voltages: risk of electric shock	Important operating instructions	Frame or chassis	Protective earth ground
Pour indiquer les risques résultant de tensions dangereuses	Pour indiquer important instructions	Masse, châssis	Terre de protection
Zu die gefahren von gefährliche spannung zeigen	Zu wichtige betriebs- anweisung und unter- haltsanweisung zeigen	Rahmen oder chassis	Die schutzerde
Para indicar azares provengo de peligroso voltajes	Para indicar importante funcionar y mantenimiento instrucciones	Armadura o chassis	Tierra proteccionista

## Declaration of Conformity

According to ISO/IEC Guide and EN 45014

*The Manufacturer:*

**Name:** Meyer Sound Laboratories  
**Address:** 2832 San Pablo Avenue  
Berkeley, California 94702-2204, USA

*declares that the product:*

**Product Name:** PSW-2  
**Product Options:** All

*conforms to the following Product Specifications:*

<b>Safety:</b>	EN 60065: 1994
<b>EMC:</b>	EN 55022: 1987 - Class A
	IEC 801-2: 1984 - 8 kV
	IEC 801-3: 1984 - 3 V/m
	IEC 801-4: 1984 - 0.5 kV Signal Lines, 1.0 kV Power Lines

*The product herewith complies with the requirements of the Low Voltage Directive 73/23/EEC and the EMC Directive 89/336/EEC.*

**Office of Quality Manager  
Berkeley, California USA  
October 1, 1995**

Made by Meyer Sound, Berkeley, CA, USA  
European Office:  
Meyer Sound Germany  
GmbH  
Carl Zeiss Strasse 13  
56751 Pösch, Germany

Environmental Specifications for Meyer Sound Electronics Products	
<b>Operating temperature:</b>	0° C to +45° C
<b>Nonoperating temp:</b>	< -40° C or > +75° C
<b>Humidity:</b>	to 95% at 35°C
<b>Operating altitude:</b>	to 4600 m (15,000 ft)
<b>Nonoperating altitude:</b>	to 6300 m (25,000 ft)
<b>Shock:</b>	30 g 11 msec half-sine on each of 6 sides
<b>Vibration:</b>	10 – 55 Hz (0.010 m peak-to-peak excursion)



---

## Introduction

---

The **Meyer PSW-2 self-powered subwoofer** contains independent amplifier and control electronics for two 15" drivers in a compact enclosure. The PSW-2 has the following acoustical specifications:

---

Frequency Response	±4 dB 35 – 120 Hz
Dynamic Range	> 110 dB
Phase Response	±30° 50 – 145 Hz

---

The PSW-2 is identical in size to, and matches well with the Meyer MSL-4. The PSW-2 also operates efficiently with the Meyer MTS-4 or CQ™ Series self-powered speakers, and can be used in any system requiring additional low frequency power.

The PSW-2's integrated design improves durability and reliability, eliminates amplifier racks, and simplifies setup and installation. The trapezoidal shape facilitates the creation of speaker arrays that maximize the coverage area for the size of the array. Rigging hardware is provided to safely suspend the PSW-2 in elevated installations.

The PSW-2 can be equipped to operate with the **Remote Monitoring System (RMS)** network and software application. RMS displays signal and power levels, driver and cooling fan status, limiter activity, and amplifier temperature for all speakers in the network on a Windows-based PC.

---

## AC Power

---

When AC power is applied to the PSW-2, the **Intelligent AC™** supply automatically selects the correct operating voltage, allowing the PSW-2 to be used internationally without manually setting voltage switches. The Intelligent AC supply performs the following protective functions to compensate for hostile conditions on the AC mains:

- suppresses high voltage transients up to several kilovolts
- filters common mode and deference mode radio frequencies (EMI)
- sustains operation during low voltage periods
- provides soft-start power-up, which eliminates high inrush current

The PSW-2 can withstand continuous voltages up to 275 V and allows any combination of voltage to GND (i.e. Neutral-Hot-GND, Hot-Hot-GND). Continuous voltages higher than 275 V may damage the unit.

The PSW-2 uses a NEMA L6-20P or IEC 309 male power inlet and satisfies UL, CSA, and EC safety standards.

## Voltage Requirements

The PSW-2 operates safely and without audio discontinuity if the AC voltage stays within either of two operating windows: 85–134 V or 165–264 V, at 50 or 60 Hz. After applying AC power, the proper operating voltage is automatically selected, but the system is muted. During the next three seconds, the primary fan turns on, the main power supply slowly ramps on, the green **Active LED** on the user panel illuminates, and the system is enabled to pass audio signals.

***TROUBLESHOOTING NOTE:** If the Active LED does not illuminate or the system does not respond to audio input after ten seconds, remove AC power. Electronics technicians with access to a test bench can contact Meyer Sound to receive The Meyer Sound Self-Powered Series MP-2 and MP-4 Field Verification Procedure (part # 17.022.066.01). This service document contains a series of tests to verify that the power supply and amplifier are functioning properly. Other users should contact Meyer Sound or an authorized service center.*

If the voltage decreases below the lower bound of either operating range (**brown-out**), the supply uses stored energy to continue functioning briefly. The unit turns off if the voltage does not increase above the threshold before the storage circuits are depleted. The time that the PSW-2 continues to operate during brown-out depends on how low the voltage drops and the audio source level during this period.

If the voltage fluctuates *within* either operating range, automatic tap selection stabilizes the internal operating voltage. This tap selection is instantaneous and there are no audible artifacts. If the voltage increases above the upper bound of either range, the power supply turns off rapidly, preventing damage to the unit.

If the PSW-2 shuts down due to either low or high voltage, the power supply automatically turns on after three seconds if the voltage has returned to either normal operating range. If the PSW-2 does not turn back on after ten seconds, remove AC power and refer to the **TROUBLESHOOTING NOTE** above.

***NOTE:** We recommend that the supply be operated at least a few volts away from the upper and lower bounds of the operating windows to avoid brown-out and possible shut-down.*

## Current Requirements

The PSW-2 presents a dynamic load to the AC mains which causes the amount of current to fluctuate between quiet and loud operating levels. Since different types of cables and circuit breakers heat up (and trip) at varying rates, it is essential to understand the types of current ratings and how they correspond to circuit breaker and cable specifications.

The **maximum continuous RMS** current is the maximum RMS current over a duration of at least 10 seconds. It is used to calculate the temperature increase in cables, which is used to select cables that conform to electrical code standards. It is also used to select the rating for slow-reacting thermal breakers.

The **maximum burst RMS** current is the maximum RMS current over a one second duration. It is used to select the rating for most magnetic breakers.

The **maximum instantaneous peak current during burst** is used to select the rating for fast-reacting magnetic breakers and to calculate the peak voltage drop in long AC cables according to the formula

$$V_{pk\_drop} = I_{pk} \times R_{total\ cable}$$

Use the table below as a guide to select cables and circuit breakers with appropriate ratings for your operating voltage.

<b>PSW-2 Current Ratings</b>			
	115 V	230 V	100 V
Max. Continuous RMS	8 A <sub>RMS</sub>	4 A <sub>RMS</sub>	10 A <sub>RMS</sub>
Max. Burst RMS	15 A <sub>RMS</sub>	8 A <sub>RMS</sub>	18 A <sub>RMS</sub>
Max. Peak During Burst	22 A <sub>PEAK</sub>	11 A <sub>PEAK</sub>	25 A <sub>PEAK</sub>

The minimum electrical service amperage required by a system of Meyer speakers is the sum of their **maximum continuous RMS** currents. We recommend allowing an additional 30% above the minimum amperage to prevent peak voltage drops at the service entry.

**TROUBLESHOOTING NOTE:** In the unlikely case that the circuit breakers trip (the white center buttons pop out), do not reset the breakers! Contact Meyer Sound for repair information.

## Safety Issues

Pay close attention to these important electrical and safety issues.



Use a power cord adapter to drive the PSW-2 from a standard 3-prong outlet (NEMA 5-15R; 125 V max).

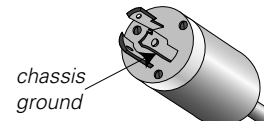

The PSW-2 requires a grounded outlet. Always use a grounding adapter when connecting to ungrounded outlets.

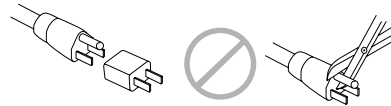

Do not use a ground-lifting adapter or cut the AC cable ground pin.



Keep all liquids away from the PSW-2 to avoid hazards from electrical shock.

Do not operate the unit if the power cables are frayed or broken.

Tie-wrap anchors on the amplifier chassis provide strain relief for the power and signal cables. Insert the plastic tie-wraps through the anchors and wrap them around the cables.

## Power Connector Wiring Conventions

Use the following AC cable wiring diagram to create international or special-purpose power connectors:

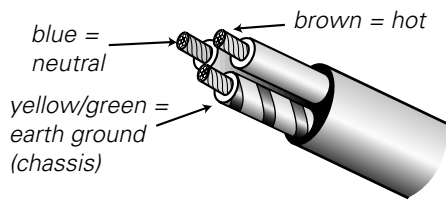

AC cable color code

If the colors referred to in the diagram don't correspond to the terminals in your plug, use the following guidelines:

- Connect the blue wire to the terminal marked with an *N* or colored black.
- Connect the brown wire to the terminal marked with an *L* or colored red.
- Connect the green and yellow wire to the terminal marked with an *E* (or  $\oplus$ ) or colored green (or green and yellow).

---

## Audio Input

The PSW-2 presents a 10 k $\Omega$  balanced input impedance to a three-pin XLR connector wired with the following convention:

- Pin 1** — 220 k $\Omega$  to chassis and earth ground (ESD clamped)
- Pin 2** — Signal
- Pin 3** — Signal
- Case** — Earth (AC) ground and chassis



Shorting an input connector pin to the case can form a ground loop and cause hum.

Pins 2 and 3 carry the input as a differential signal; their polarity can be reversed with the **input polarity** switch on the user panel. If the switch is in the up position, pin 2 is hot relative to pin 3, resulting in a positive pressure wave when a positive signal is applied to pin 2. Use standard audio cables with XLR connectors for balanced signal sources.

**TROUBLESHOOTING NOTE:** If abnormal noise (hum, hiss, popping) is produced from the loudspeaker, disconnect the audio source from the speaker. If the noise stops, then the problem is not within the loudspeaker; check the audio input and AC power.

A single source can drive multiple PSW-2s with a parallel input loop, creating an unbuffered hardwired loop connection. Make certain that the source equipment can drive the total load impedance presented by the parallel input circuit. For example, since the input impedance of a single PSW-2 is 10 k $\Omega$ , cascading 20 PSW-2s produces a balanced input impedance of 500  $\Omega$ . If a 150  $\Omega$  source is used, the 500  $\Omega$  load results in a 2.28 dB loss.

---

## Amplification and Protection Circuitry

Each driver in the PSW-2 is powered by one channel of the Meyer MP-2, a 1240 W amplifier (620 W/channel) utilizing complementary power MOSFET output stages (class AB/H). The following sections discuss the MP-2's limiting circuitry and the two-fan cooling system.

### TruPower™ Limiting System

Conventional limiters assume that the resistance of a speaker remains constant and set the limiting threshold by measuring voltage only. This method is inaccurate because the speaker's resistance changes in response to the frequency content of the source material and thermal variations in the speaker's voice coil and magnet. Conventional limiters begin limiting prematurely, which under-utilizes system headroom and deprives the speaker of its full dynamic range.

The TruPower limiting (TPL) system accounts for varying speaker impedance by measuring current, in addition to voltage, to compute the power dissipation and voice coil temperature. TPL improves performance before and during limiting by allowing the speaker to produce its maximum SPL across its entire frequency range. TPL also extends the lifetime of the drivers by controlling the temperature of the voice coil.

When the safe continuous power level is exceeded, a single limiter engages, affecting both amplifier channels equally. TPL activity is indicated by the **Sub Limit** LED on the user panel. The limiter ceases operation when the power level returns to normal and does not affect the signal when the LED is inactive.

The PSW-2 performs within its acoustical specifications and operates at a normal temperature if the TPL LED is on for no longer than two seconds, and off for at least one second. If the LED remains on for longer than three seconds, the PSW-2 is *hard limiting* with these negative consequences:

- Increasing the input level will not increase the volume.
- The system distorts due to clipping and nonlinear driver operation.
- The life-span of driver and amplifier components is reduced because they are subjected to excessive heat.

The TPL LED can indicate an imbalance in a system of speakers by functioning like a spectrum analyzer. If speakers in a subwoofer, mid-bass, or mid-hi subsystem begin to limit before reaching the required operating level for the entire system, then that subsystem needs to be supplemented with additional speakers.

*NOTE: Although the TPL limiters exhibit smooth sonic characteristics, we do not recommend using them for intentional compression effects. Use an outboard compressor/limiter to compress a mixed signal.*

## Driver Excursion Clamp

The drivers in the PSW-2 are protected from over-excursion by an **excursion clamping circuit** that does not have attack or release time constants. The circuit provides instantaneous braking for the drivers without the *pumping* effects commonly produced by compressor/limiters.

The circuit uses sophisticated filters to minimize the distortion normally caused by clamping and clipping. As the PSW-2's input signal is increased past the clamping point, the output signal remains at a fixed level, protecting the drivers and minimizing negative sonic effects. The PSW-2 operates safely if the **Exc. Clamp** LED is on for no longer than two seconds, and off for at least one second.

## Fans and Cooling System

The PSW-2 uses a forced-air cooling system with two fans to prevent the amplifiers from overheating. The fans draw air in through ducts on the front of the cabinet, over the heatsinks, and out the rear of the cabinet. Since dust does not accumulate in the amplifier circuitry, its life-span is increased significantly.

A foam insert filter, in combination with the entire front grill surface, acts as an air filter for the cooling system. Despite the filtering, extensive use or a dusty operating environment can allow dust to accumulate along the path of the airflow, preventing normal cooling. We recommend periodically removing the grill, filter, and amplifier module and using a vacuum cleaner to clear dust from the grill, filter, fans, and heatsinks. Make sure that the air ducts are clear and that there is at least six inches clearance for exhaust behind the cabinet.

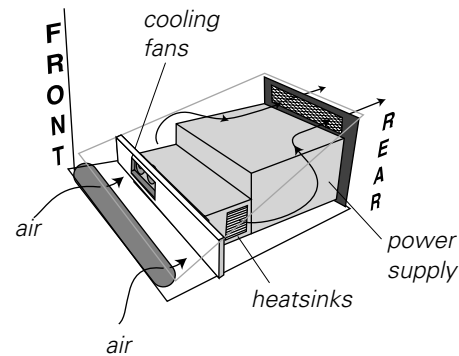

A variable-speed primary fan runs continuously with an inaudible operating noise of 22 dBA at 1 m at its slowest speed. The speed of the primary fan begins increasing when the temperature of the heatsinks reaches 42°C. The fan reaches full speed at 62°C and is barely audible near the cabinet, even without an audio signal.

In the unusual event that the heatsink temperature reaches 74°C, the secondary fan turns on; it turns off when the temperature decreases to 68°C. The secondary fan is audible at close proximity without an audio signal and turns on in response to

- primary fan failure (check its status immediately);
- accumulation of dust in the cooling system path;
- a prolonged period of high source levels in hot temperatures or direct sunlight;
- driver failure.

*TROUBLESHOOTING NOTE: In the highly unlikely event that the secondary fan does not keep the temperature below 85°C, the PSW-2 automatically shuts down until AC power is removed and reapplied. If the PSW-2 shuts down again after cooling and reapplying AC power, contact Meyer Sound for repair information.*

---

## Rigging

---

The PSW-2 weighs 162 lb (73.5 kg). The maximum recommended load for a single cabinet with aircraft pan fittings is 600 lb (273kg). This *working* load is based on a 5:1 safety factor. The PSW-2 has six rigging brackets (three on top and bottom). Each bracket is capable of supporting the full working load of the cabinet.

There are four types of interchangeable rigging brackets, each fastened by six Phillips screws:

- aircraft pan fittings (ring and stud)
- $\frac{3}{8}$ "-16 nut plates
- M-10 x 1.5 metric nut plates
- blank plates (if no rigging brackets are requested)

*NOTE: Units with nut plates are rated for the weight of one cabinet only.*

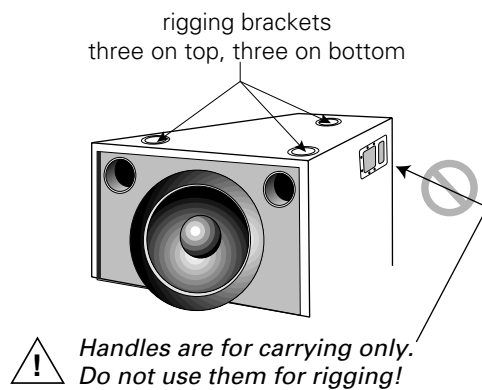

Rigging load ratings assume a straight tensile pull and that the cabinet is in new condition with aircraft pan fittings. If the preceding conditions are not met, or the rigging is worn or damaged, the load ratings can be reduced significantly. Inspect the rigging hardware regularly and replace worn or damaged components immediately.

The cabinet, exposed electronic circuitry, and drivers can receive protective treatment that permits safe use in wet conditions. Additionally, a rain hood can be fitted to shield cables and electronics. *Do not install a unit outdoors without weather protection!* Contact Meyer Sound for more information.

*NOTE: All Meyer Sound products must be used in accordance with local, state, federal, and industry regulations. It is the owner's and/or user's responsibility to evaluate the reliability of any rigging method for their application. Rigging should be done only by experienced professionals.*

---

## Configuration, Placement, and Polarity

---

Designing a full-range system requires an understanding of how subwoofers respond when grouped together, how they interact with nearby walls and floors, and how their location in a system affects the choice of polarity to use for other speakers. These topics are introduced as background for the section *Full-Range Systems*.

### Configuration

A single subwoofer has an essentially omnidirectional coverage pattern. A horizontal line with two adjacent subs narrows the horizontal coverage area, without changing the vertical coverage, compared to one sub. A vertical stack of two subs narrows the vertical coverage without changing the horizontal coverage. In both cases, there is 3 to 6 dB SPL of on-axis addition.

Increasing the size of the horizontal or vertical array from two to three subs further narrows the respective *H* or *V* coverage without changing the corresponding *V* or *H* coverage. Both the vertical and horizontal three-sub arrays provide approximately 10 dB SPL addition more than one sub.

Increasing the number of subs in the horizontal or vertical array increases the corresponding *H* or *V* directional control and the system SPL. A properly designed vertical array steers low frequencies to include balconies and upper tiers but avoids unnecessary interaction with the ceiling; a horizontal array focuses low frequencies for the longer throw distances required by large venues.

The three-by-two array (below left) narrows the *H* and *V* coverages, and produces 10 to 15 dB SPL more than a single sub. Combining the vertical and horizontal arrays in an *L*-configuration (below right) provides more on-axis SPL and directional control than the three-by-two array.

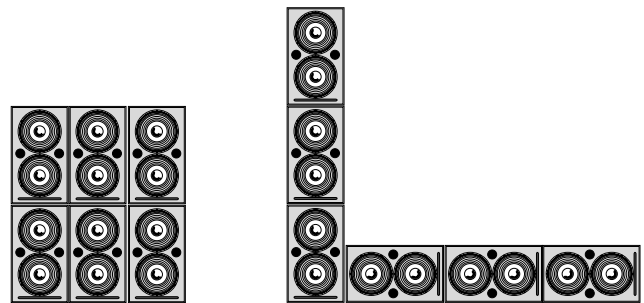

*Both the three-by-two group and L-configuration increase the SPL and directional control.*

## Placement

One of the most important factors governing subwoofer response is their placement relative to adjacent surfaces. Subwoofers gain significant power by coupling, or *loading*, with nearby floors and walls. *Half-space* loading describes a speaker coupling with one surface. Subs placed on the floor benefit from half-space loading, while flown subs in free-space (without a nearby wall or ceiling) do not. In general, subs in half-space generate twice the SPL (+6 dB) compared to the same number in free-space.

It can be beneficial to fly subwoofers, despite the lack of half-space loading. Placing subwoofers within a flown cluster of mid-hi speakers creates a smooth frequency image because the subs are not separated by the distance from the cluster to the floor.

*NOTE: SPL values refer to an on-axis measurement position. The actual SPL addition and narrowing of coverage varies with frequency and depends on the distance between cabinets, loading conditions, and room acoustics.*

## Polarity

The cabinets in the *Full-Range Systems* section are in a close-proximity coplanar orientation, unless otherwise stated. Separating a mid-hi speaker from a subwoofer by more than 5 ft may require setting the speakers to opposite polarities to compensate for the propagation delay from each speaker to the designated listening or measurement position.

In a coplanar orientation, externally amplified Meyer subwoofers require the opposite polarity setting to all Meyer self-powered speakers.

---

## Measurement and System Integration Tools

---

It is essential that even the most carefully assembled sound systems be analyzed with precise measurement tools. We recommend using the Meyer **SIM® System II Sound Analyzer** and **CP-10 Parametric Equalizer** to

- assist the process of choosing and configuring speakers;
- measure propagation delays between subsystems to set the correct polarity and delay times;
- measure and equalize variations in frequency response caused by the acoustical environment and the placement and interaction of speakers.

We recommend using the Meyer **LD-1A Line Driver** to integrate different types of Meyer self-powered speakers into a complete system. The LD-1A has two channels equipped to control a full-range main system, and six auxiliary channels for down-fill, front-fill, and delay systems. The LD-1A maintains signal integrity for long cable paths and provides the following useful functions:

- The **Lo Cut** switch activates a high-pass filter (160 Hz, -12 dB/oct, Q = 0.8) that performs a crossover function for the Mid-Hi output.
- The **DS-2 & Sub Crossover** switch (channels 1 and 2 only) activates a crossover network optimized for the DS-2P when used with the PSW-2 or 650-P. With the switch **in**, frequencies below 80 Hz are sent to the Sub output (for the 650-P), and above 80 Hz to the DS-2 output. When the subwoofer is used without the DS-2P, the switch should be **out**, which sends a full-range signal to both the DS-2 and Sub outputs.
- The **DS-2  $\phi$**  and **Sub  $\phi$**  switches (channels 1 and 2 only) toggle the polarity for the DS-2 and Sub outputs.
- The **Mid-Hi**, **DS-2**, and **Sub** outputs (channels 1 and 2 only) each have their own gain control and mute switch.

*POLARITY NOTE: The polarity for Meyer self-powered speakers may be reversed using the input polarity switch on the user panel. The LD-1A also allows polarity reversal with the DS-2  $\phi$  and Sub  $\phi$  switches for speakers connected to the DS-2 and Sub outputs. When making polarity decisions in applications that include the LD-1A, check the state of all polarity switches.*

---

## Full-Range Systems

---

### Meyer Speaker Types

The following Meyer speakers are mentioned in the example applications.

<b>MSL-4</b>	Self-powered mid-hi speaker
<b>CQ Series</b>	Self-powered mid-hi speaker
<b>MTS-4</b>	Self-powered full-range speaker
<b>650-P</b>	Self-powered subwoofer
<b>USW-1</b>	Externally amplified subwoofer

The Meyer self-powered speakers listed above have a **loop** connection to send the input signal to another speaker. Full-range signals may be applied to all Meyer self-powered subwoofers because they have built-in active crossovers that filter mid-hi frequencies.



## PSW-2 and MSL-4

The PSW-2 is compatible with the MSL-4, CQ, and MTS-4. However, since the LF (low frequency) response for each speaker overlaps with the PSW-2, the system frequency response exhibits a rise in the range 65–120 Hz (MSL-4), 40–120 Hz (CQ), and 30–120 Hz (MTS-4). It is important to emphasize that the speakers are in phase in this region. The rise can be corrected using the Meyer CP-10 Parametric Equalizer, if desired.

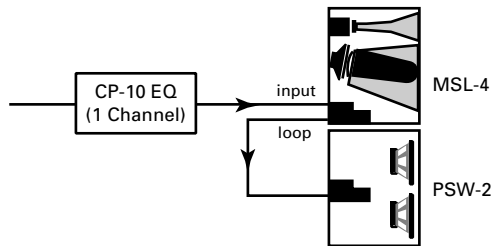

Set the MSL-4 and PSW-2 to the same polarity.

## LD-1A with PSW-2 and MSL-4

Activating the Lo Cut filter on the LD-1A for the CH 1 Mid-Hi output also eliminates the LF rise caused by the overlap between the MSL-4 and PSW-2. Although a typical MSL-4 : PSW-2 ratio is 2:1, CH 1's Sub and Mid-Hi level controls allow the ratio to vary while maintaining control of the spectral balance of the system.

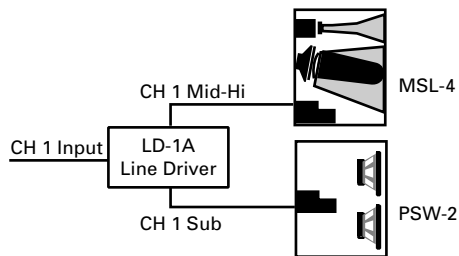

Set the MSL-4 and PSW-2 to the same polarity.

## LD-1A with Flown PSW-2 and MSL-4; 650-P on the Floor

Including subwoofers in a flown cluster provides a smooth frequency image because the low and mid-hi frequencies are produced from speakers located close together. The identical dimensions of the PSW-2 and MSL-4 allow them to be easily flown together.

The CH 1 Mid-Hi output drives the MSL-4 with the Lo Cut filter **in**. The CH 1 Sub and DS-2 outputs drive the 650-Ps and PSW-2s with the DS-2 & Sub Crossover switch **out**, which sends a full-range signal with independent level control to each speaker.

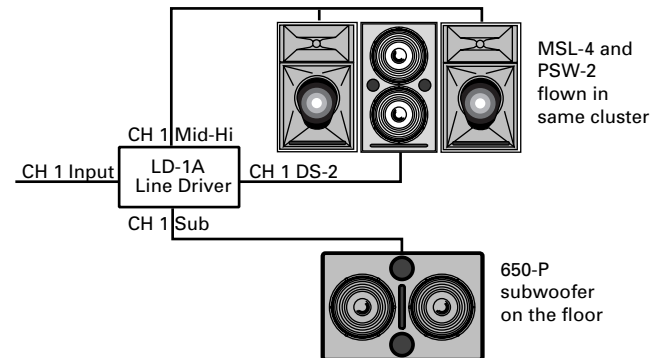

Set the MSL-4 and PSW-2 to the same polarity. The polarity for the 650-P depends on the distance of the measurement position relative to the subwoofers and the flown cluster.

## PSW-2 and USW-1

Although it is preferable to employ the PSW-2 in a completely self-powered system, the PSW-2 can be used with the USW-1 externally amplified subwoofer *if*:

- the B-2EX CEU is set to the maximum output level;
- the USW-1's amplifier is set to 26 dB gain;
- the PSW-2 is set to the opposite polarity to the USW-1 amplifier.

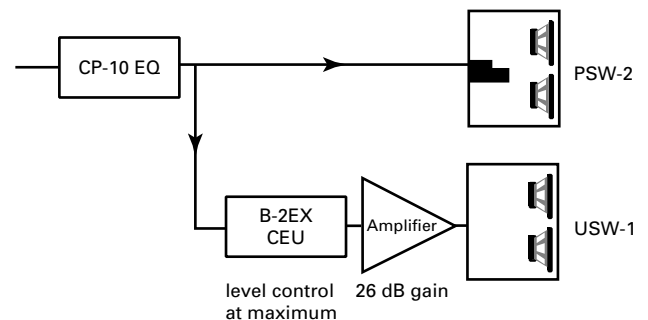

Set the PSW-2 to the opposite polarity to the USW-1 amplifier.

**POLARITY NOTE:** It is advisable to check the polarity of adjacent PSW-2 and USW-1 cabinets by following the instructions in the *Verifying Driver Polarity* section on page 10.

---

## Driver Troubleshooting

---

The Remote Monitoring System (RMS) is the best method to query the status of the drivers in a system before and during the performance. RMS monitors peak power, peak voltage, and average voltage (VU) for each amplifier channel, allowing immediate detection and muting for drivers with open or shorted voice coils, with minimal disruption to the system. Contact Meyer Sound for more information about RMS.

In the absence of RMS, several methods can be employed to obtain information about the state of the drivers.

### Troubleshooting with TPL

The TPL LED can indicate serious driver problems, if interpreted correctly. If one PSW-2 in a system exhibits substantially more TPL activity than others receiving the same audio signal, then one or both drivers in that unit may have a short circuit. This is a potentially dangerous condition for the electronics; shut the PSW-2 down immediately.

The TPL circuit does not activate if there is no power dissipation in the driver, regardless of the input signal level. Therefore, if all PSW-2s in a system receiving the same audio signal exhibit TPL activity except one, then that unit may have an open voice coil; disconnect it and contact Meyer Sound for repair information.

### Driver Replacement

To determine whether a driver is functioning properly, or replace a damaged driver, contact Meyer Sound to obtain the *Low Driver Inspection and Evaluation Procedure for Self-Powered Series Products* (part # 17.010.120.01).

### Verifying Driver Polarity

Incorrect driver polarity impairs system performance and may damage the drivers. All Meyer loudspeakers are shipped with the drivers in correct alignment. However, if the driver or circuit wiring has been removed or disassembled in any loudspeaker in a system for any reason, it is essential to check the polarity between drivers in the same cabinet and between adjacent loudspeakers.

*NOTE: Since polarity reversal causes excessive driver excursion at high source levels, use moderate levels for these tests.*

### Driver Polarity in the Same Loudspeaker

A cabinet with two identical drivers receiving the same input signal produces an extremely low amplitude output signal if the polarity of the drivers is reversed. Use the following test procedure to verify the polarity between drivers in the same loudspeaker:

1. Place a measurement microphone 3 ft from the front of a loudspeaker that is known to be wired correctly, at the mid-point between the two drivers.
2. Connect a signal source to the loudspeaker and note the frequency response and overall level.
3. Place a measurement microphone 3 ft from the front of the loudspeaker with unknown polarity, at the mid-point between the two drivers.
4. Connect a signal source to the loudspeaker and note the frequency response and overall level.

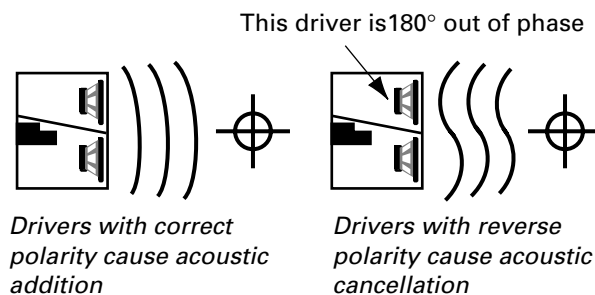

The polarity is correct if the frequency response remains constant for both tests, with the same overall level. Broadband cancellation (decreased overall level) for the cabinet being tested indicates polarity reversal.

### Polarity Between Adjacent Loudspeakers

Use the following test procedure to verify the polarity between adjacent loudspeakers of the same type:

1. Position two loudspeakers adjacent to each other.
2. Place a measurement microphone 3 ft from the speakers on the axis between them.
3. Connect a signal source to one speaker and note the frequency response and overall level.
4. Apply the same signal to the second speaker with the first speaker still connected.

The polarity is correct if the frequency response remains constant with a significant increase in amplitude. Broadband cancellation indicates polarity reversal.

*NOTE: Checking the polarity of more than two adjacent cabinets in one test may damage the drivers in the cabinet with reversed polarity.*



## Safety Summary



### English

- To reduce the risk of electric shock, disconnect the loudspeaker from the AC mains before installing audio cable. Reconnect the power cord only after making all signal connections.
- Connect the loudspeaker to a two-pole, three wire grounding mains receptacle. The receptacle must be connected to a fuse or circuit breaker. Connection to any other type of receptacle poses a shock hazard and may violate local electrical codes.
- Do not install the loudspeaker in wet or humid locations without using weather protection equipment from Meyer Sound.
- Do not allow water or any foreign object to get inside the loudspeaker. Do not put objects containing liquid on, or near, the unit.
- To reduce the risk of overheating the loudspeaker, avoid exposing it to direct sunlight. Do not install the unit near heat emitting appliances, such as a room heater or stove.
- This loudspeaker contains potentially hazardous voltages. Do not attempt to disassemble the unit. The unit contains no user serviceable parts. Repairs should be performed only by factory trained service personnel.

### Français

- Pour réduire le risque d'électrocution, débrancher la prise principale de l'haut-parleur, avant d'installer le câble d'interface allant à l'audio. Ne rebrancher le bloc d'alimentation qu'après avoir effectué toutes les connexions.
- Branchez l'haut-parleur dans une prise de courant à 3 dérivations (deux pôles et la terre). Cette prise doit être munie d'une protection adéquate (fusible ou coupe-circuit). Le branchement dans tout autre genre de prise pourrait entraîner un risque d'électrocution et peut constituer une infraction à la réglementation locale concernant les installations électriques.
- Ne pas installer l'haut-parleur dans un endroit où il y a de l'eau ou une humidité excessive.
- Ne pas laisser de l'eau ou tout objet pénétrer dans l'haut-parleur. Ne pas placer de récipients contenant un liquide sur cet appareil, ni à proximité de celui-ci.
- Pour éviter une surchauffe de l'haut-parleur, conserver-la à l'abri du soleil. Ne pas installer à proximité d'appareils dégageant de la chaleur tels que radiateurs ou appareils de chauffage.
- Ce haut-parleur contient des circuits haute tension présentant un danger. Ne jamais essayer de le démonter. Il n'y a aucun composant qui puisse être réparé par l'utilisateur. Toutes les réparations doivent être effectuées par du personnel qualifié et agréé par le constructeur.

### Deutsch

- Um die Gefahr eines elektrischen Schlages auf ein Minimum zu reduzieren, den Lautsprecher vom Stromnetz trennen, bevor ggf. ein Audio-Schnittstellensignalkabel angeschlossen wird. Das Netzkabel erst nach Herstellung aller Signalverbindungen wieder einstecken.
- Der Lautsprecher an eine geerdete zweipolige Dreiphasen-Netzsteckdose anschließen. Die Steckdose muß mit einem geeigneten Abzweigschutz (Sicherung oder Leistungsschalter) verbunden sein. Der Anschluß der unterbrechungsfreien Stromversorgung an einen anderen Steckdosentyp kann zu Stromschlägen führen und gegen die örtlichen Vorschriften verstoßen.
- Der Lautsprecher nicht an einem Ort aufstellen, an dem sie mit Wasser oder übermäßig hoher Luftfeuchtigkeit in Berührung kommen könnte.
- Darauf achten, daß weder Wasser noch Fremdkörper in das Innere den Lautsprecher eindringen. Keine Objekte, die Flüssigkeit enthalten, auf oder neben die unterbrechungsfreie Stromversorgung stellen.
- Um ein Überhitzen dem Lautsprecher zu verhindern, das Gerät vor direkter Sonneneinstrahlung fernhalten und nicht in der Nähe von wärmeabstrahlenden Haushaltsgeräten (z.B. Heizgerät oder Herd) aufstellen.
- Im Inneren diesem Lautsprecher herrschen potentiell gefährliche Spannungen. Nicht versuchen, das Gerät zu öffnen. Es enthält keine vom Benutzer reparierbaren Teile. Reparaturen dürfen nur von ausgebildetem Kundendienstpersonal durchgeführt werden.

### Español

- Para reducir el riesgo de descarga eléctrica, desconecte de la red el altoparlante antes de instalar el cable de señalización de interfaz de la señal. Vuelva a conectar el conductor flexible de alimentación solamente una vez efectuadas todas las interconexiones de señalización.
- Conecte el altoparlante a un tomacorriente bipolar y trifilar con neutro de puesta a tierra. El tomacorriente debe estar conectado a la protección de derivación apropiada (ya sea un fusible o un disyuntor). La conexión a cualquier otro tipo de tomacorriente puede constituir peligro de descarga eléctrica y violar los códigos eléctricos locales.
- No instale el altoparlante en lugares donde haya agua o humedad excesiva.
- No deje que en el altoparlante entre agua ni ningún objeto extraño. No ponga objetos con líquidos encima de la unidad ni cerca de ella.
- Para reducir el riesgo de sobrecalentamiento, no exponga la unidad a los rayos directos del sol ni la instale cerca de artefactos que emiten calor, como estufas o cocinas.
- Este altoparlante contiene niveles de voltaje peligrosos en potencia. No intente desarmar la unidad, pues no contiene piezas que puedan ser reparadas por el usuario. Las reparaciones deben efectuarse únicamente por parte del personal de mantenimiento capacitado en la fábrica.

# Controls and Connectors

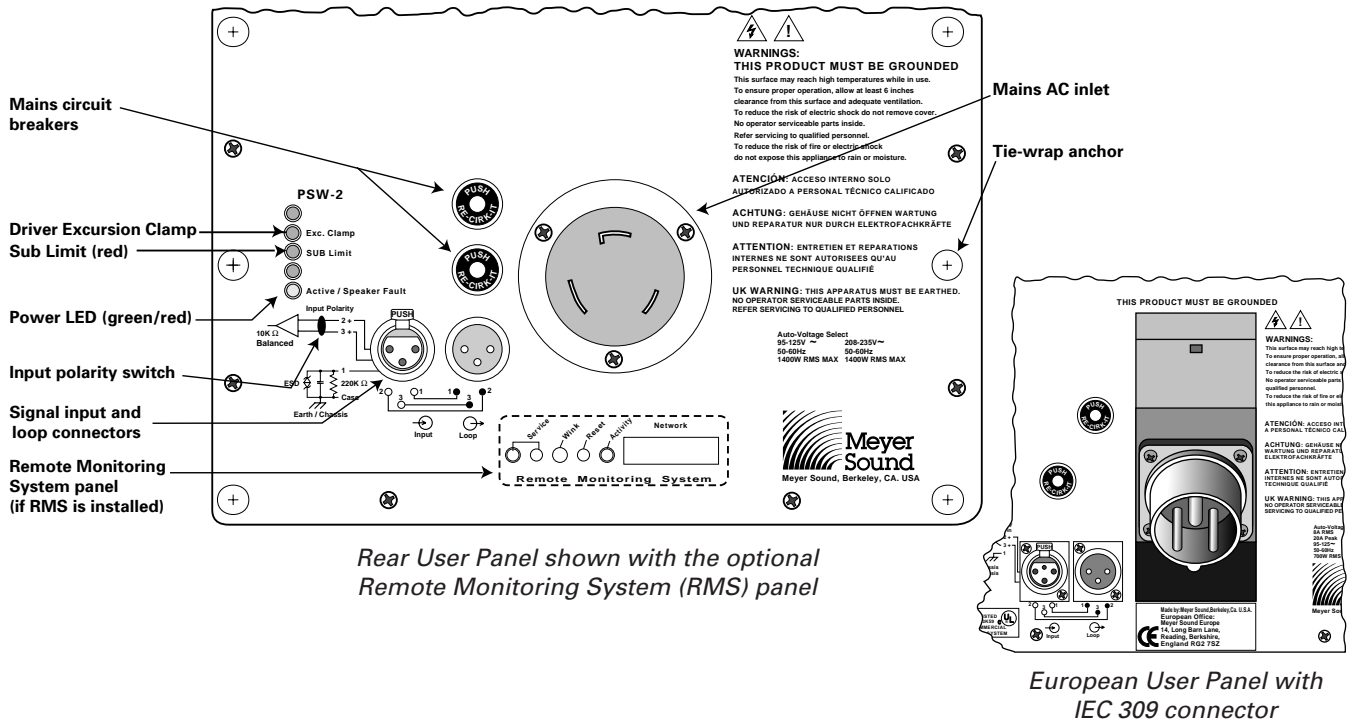

Rear User Panel shown with the optional Remote Monitoring System (RMS) panel

European User Panel with IEC 309 connector

## Dimensions

All units in inches

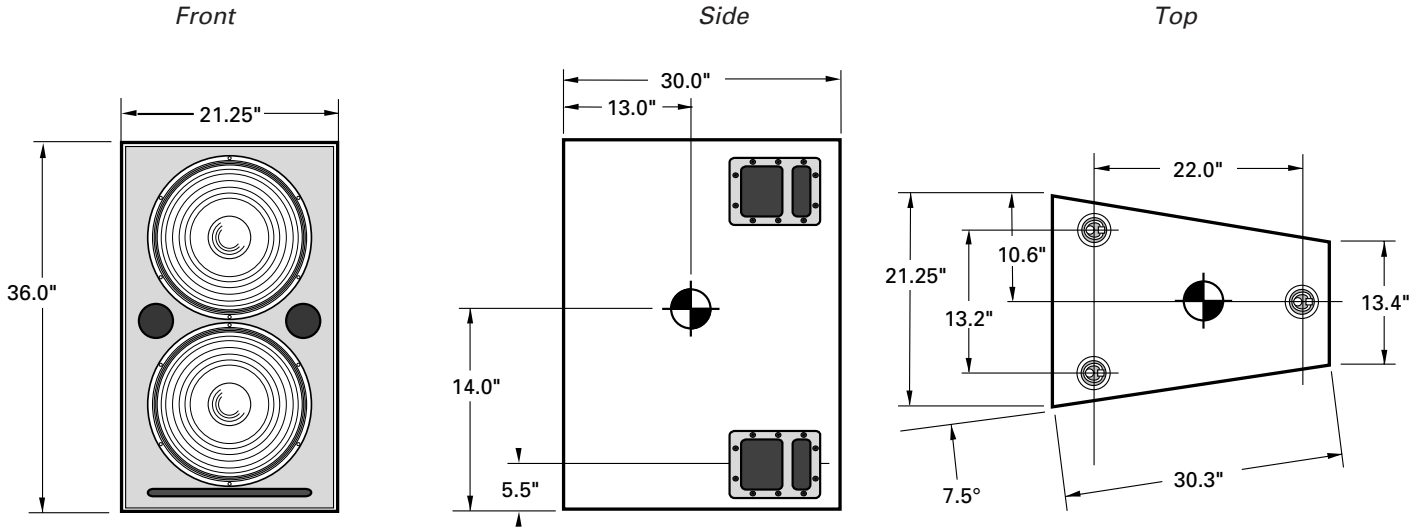

## Contact Information

**Meyer Sound Laboratories, Inc.**  
 2832 San Pablo Avenue  
 Berkeley, California 94702  
 Telephone: 510 - 486 - 1166  
 FAX: 510 - 486 - 8356  
 E-mail: techsupport@meyersound.com  
 http://www.meyersound.com

**Meyer Sound Germany Gmbh**  
 Carl Zeiss Strasse 13  
 56751 Polch, Germany  
 Telephone: 49.2654.9600.58  
 FAX: 49.2654.9600.59