



## CCD Micro Cameras **GP-US932 | GP-US742 | GP-KS822**

Unparalleled flexibility – Quality wherever it counts

True HD

Progressive Scan

Brilliant Colour Reproduction

Compact Design

Digital Signal Processing

## Panasonic Micro Cameras: More than just a point of view



Micro cameras are now capable of achieving what only complex specialised solutions hitherto could do: extremely high resolution, the purest colour reproduction and impressive accuracy. Panasonic's micro cameras guarantee maximum performance for the most diverse applications - and are also available as OEM components.

### Dynamically digital

Panasonic's micro cameras feature broadband and low-noise signal processing. The latest generation digital signal processors allow for flexible signal processing, for example, the brightness can be adjusted quickly and uniformly even in rapidly changing light conditions.

Our micro cameras boast a number of other practical, specialist functions:

- Freeze-frame
- 2.5x continuous electronic zoom
- Frequency-independent 2D edge enhancement
- 2D low-pass filter to control disruptive moiré effects
- Parallel definition of two or more user settings
- 5 digital special filters, e.g. for red enhancement

### Small in size – big on performance

To make our camera systems as small and compact as possible, we have separated the camera head from the signal processing unit. Which means that the camera can be used even when space is at a premium. And despite the small scale, the control unit is as powerful as ever.

### Progressive Scan: Giving quality a boost

Conventional, linear image scanning (interlace) is suitable for capturing static images or for shots with increased light sensitivity. By contrast, progressive scanning used in Panasonic's micro cameras captures the entire image, which is ideal for capturing moving objects. And the pictures are much sharper compared to those captured by interlace scanning.



Image captured with progressive scan



Image captured without progressive scan (interlace)

## 1CCD and 3CCD camera systems

A CCD component converts light signals into electric signals. With the 1CCD camera system, a colour filter separates the light into complementary colours which are all captured by just one CCD. In cameras that use the 3CCD approach, a prism splits the light into the three primary colours, namely red, green and blue. The individual colour information is sent to separate CCDs. Consequently, the brilliance of the colours, accuracy of detail and depth of focus are increased.

## Heat-resistant components

In medical applications or specialist industrial solutions, micro cameras need to be extremely heat-resistant. Which is why selected components in our micro cameras can withstand temperatures of up to 125° C and can be integrated into autoclavable camera systems.

## Well connected

Depending on the model, the control units on the Panasonic micro cameras are equipped with SDI, analogue RGB/component, S-Video and FBAS video outputs for flexible connectivity.

## A powerful individual unit or a perfect integrated solution

The camera system components are designed to work in perfect harmony, and yet can also be combined with other products.

- Lenses: Panasonic special lenses or high-grade TV lenses from third-party manufacturers
- Heads: available in 1CCD and 3CCD versions and different sizes
- Cable: available in different lengths
- Control unit: varying functional range for 1CCD or 3CCD versions, with casing or circuit board

## Components

1) Head unit with lens

2) Sensor cable

3) CCU control circuit board

4) Monitor

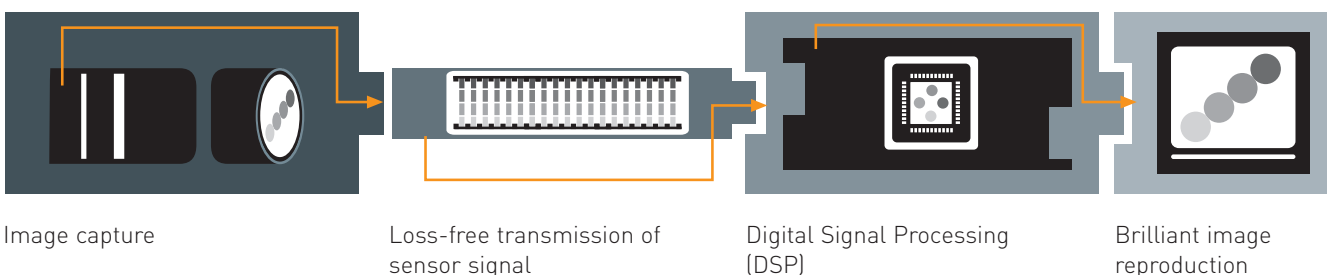

## Easy to operate

We have developed a system of user-friendly on-screen menus to ensure easy and effective use of our micro cameras. This means you can change parameters quickly and clearly during operation. It is also extremely easy to save individual settings as presets for different users. The on-screen menu of OEM components can be adapted to customer requirements.

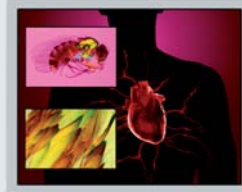

### Colours

The Panasonic micro cameras' 6 or 12-axis colour matrix allows individual colour ranges to be separately adjusted.



### Zoom

Get in close with the 2.5x continuous electronic zoom and frequency-independent 2D edge enhancement.

## Natural brilliant colour

Optimised, true colour reproduction is a given – and our micro cameras' 6 or 12-axis colour matrix allows individual colour ranges to be separately adjusted. This means that reds can be enhanced – as is common, for example, in medical applications or biological research.

## High Definition: The best picture quality



High Definition

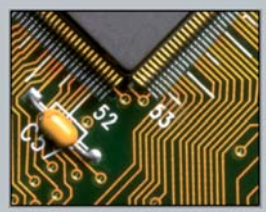

Standard Definition

### It doesn't get any sharper

Genuine 16:9 multi-format HD quality from a micro camera – Panasonic has met the demands of countless users. For outstanding sharpness, extraordinarily true colours and flicker-free images.

### Greater clarity and a brighter picture even in the dark

The simple fact is that with HD technology, you see more. Images can be reproduced in fine detail over the entire frequency spectrum by sharpening low-frequency parts of an image. And the high light sensitivity of an HD camera ensures clearer images even in light and dark areas. Such features are particularly important, for example, in endoscopic applications.

### Impressive performance

Panasonic's 3CCD HD micro camera systems feature three 1/3" 16:9 progressive HD sensors. With 60

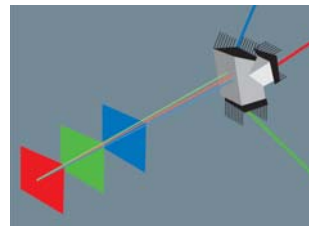

images per second, you can work with both a horizontal resolution of 1080 lines (interlaced scanning) and 720 lines (progressive scanning).

### Quality starts with the head

With Panasonic's HD micro cameras, the video signal is digitised in the camera head. Signal transmission bandwidth is 3 x 14 bit and signal processing in the control unit is virtually loss-free at a bandwidth of 3 x 19 bit.

### Colours on demand

Panasonic's 3CCD HD micro cameras feature a 12-axis colour matrix that allows for separate adjustment of individual colour ranges. The colour accentuation that this permits, without influencing other colours, ensures a particularly high level of flexibility in scientific applications or industrial solutions.

Colour enhancement: yellow



Colour enhancement: red



Colour enhancement: blue



### Digital interfaces

To prevent high-resolution images from suffering any loss of data and therefore any reduction in quality when they leave the control unit, our systems are equipped with digital HD-SDI interfaces. They therefore allow video signals to be transmitted over long distances.

# The new GP-US932 3CCD HD micro camera system

Panasonic's first 3CCD HD micro camera meets the demand of countless users for miniaturised camera systems capable of delivering genuine HD quality. A separate camera head that is connected by cable allows the camera to be used where space is at a premium.



## Features

- 1920 x 1080 pixel resolution in 1080i format
- 1/3" 3CCD camera head
- A/D conversion in the head
- Digital transmission via signal cable
- Easy-to-use on-screen display
- 3 configurable user settings
- Dynamic range [D-range] can be extended
- Low frequency booster

## Overview of controls and connections

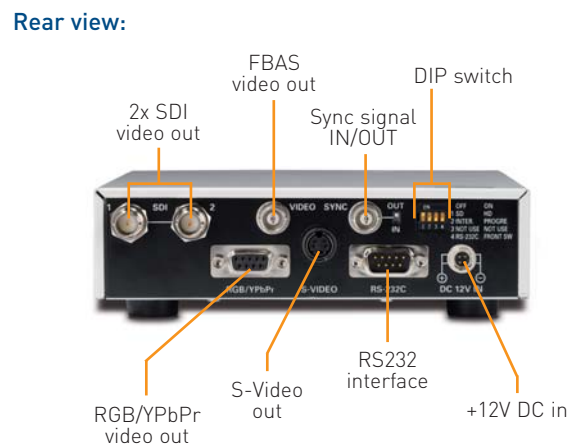
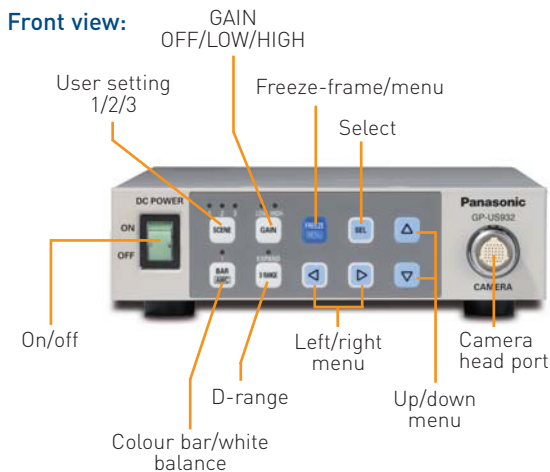

## System components



- GP-US932CUT** control unit
- Standard version with casing
  - Supports 1/3" 3CCD camera head
  - Analogue outputs: 1 x FBAS, 1 x Y/C, 1 x RGB/YPbPr
  - Digital outputs: 2 x HD-SDI
  - Synchronisation: internal or external
  - Dimensions (W X H X D): 170 x 44 x 229 mm



- GP-US932CBVE** circuit board
- OEM version without casing
  - Supports 1/3" 3CCD camera head
  - Analogue outputs: 1 x FBAS, 1 x Y/C, 1 x RGB/YPbPr
  - Digital outputs: 2 x HD-SDI
  - Synchronisation: internal or external
  - Dimensions (W X H X D): 140 x 30 x 185 mm



- GP-US932HT** 1/3" 3CCD camera head
- Standard version with casing
  - Progressive scan sensor
  - 3 x 14bit digital signal transmission
  - 54 dB S/N ratio
  - C-mount lens connection
  - Dimensions without socket (W x H x D): 37 x 47 x 69 mm



- GP-CA932/4** camera head signal cable
- 4 m length
- GP-CA932/6** camera head signal cable
- 6 m length

## 3CCD as industry standard: GP-US742 series

Thanks to progressive scanning, this 3CCD camera system ensures extremely high resolution, brilliant colours and high light sensitivity, all features that are crucial in the industrial and research sectors, as well as specialist monitoring and broadcasting applications.



### Features

- Freeze-frame
- 2.5x continuous electronic zoom
- Frequency-independent 2D edge enhancement
- 2D low-pass filter to control disruptive moiré effects
- Parallel definition of two parameter settings, allowing camera configuration to be changed quickly
- 5 digital special filters, for example, for red and edge enhancement
- Gamma functions for improving contrast
- 1/2" head: 800 line resolution, high sensitivity
- 1/3" head with progressive scan
- 1/4" heat resistant head with progressive scan
- 6-axis colour matrix

### Overview of controls and connections

#### Front view:

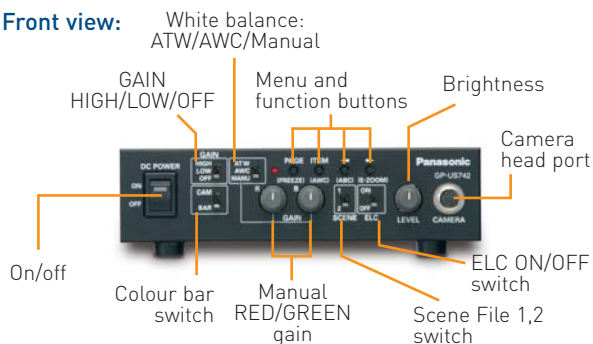

#### Rear view:

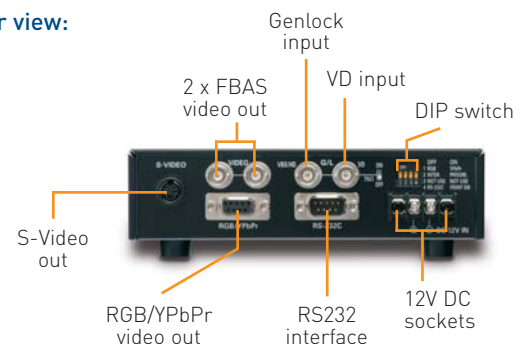

### System components



- GP-US742CUE** control unit
- Version with casing
  - Supports 1/2", 1/3" and 1/4" 3CCD heads
  - Analogue outputs: 2 x FBAS, 2 x Y/C, 1 x RGB/YPbPr
  - Synchronisation: internal or external (Genlock)
  - Dimensions (W x H x D): 170 x 44 x 229 mm



- GP-US742CBVE** circuit board
- OEM version without casing
  - Controllable via RS-232C interface
  - Supports 1/2", 1/3" and 1/4" 3CCD heads
  - Synchronisation: internal or external
  - 3 x 10bit digital interface
  - Dimensions (W x H x D): 140 x 20 x 200 mm



- GP-CA522/4** signal cable
- 4 m length



- GP-NT12** external mains adapter
- Primary 100 V to 240 V AC, 50/60 Hz
  - Secondary 12 V DC 1.5 A



- GP-US522HBE** 1/2" 3CCD camera head
- Version with casing
  - Interlace scan IT sensor
  - Resolution: 800 TV lines
  - 62 dB S/N ratio
  - Special C-mount lens connection
  - Dimensions (W x H x D): 34 x 44 x 52 mm



- GP-US732HE** 1/3" 3CCD camera head
- Version with casing
  - Progressive scan IT sensor
  - Resolution: 750 TV lines
  - 62 dB S/N ratio
  - C-mount lens connection
  - Dimensions (W x H x D): 34 x 44 x 52 mm



- GP-US742HWE** 1/4" 3CCD camera head
- OEM version without casing
  - Progressive scan IT sensor
  - Resolution: 700 TV lines
  - 60 dB S/N ratio
  - Heat-resistant to 125°C
  - 34 (Ø) x 90 (L) mm

The brilliance and versatility of 3CCD technology are now available with Panasonic's OEM components. The cost-effective way to embrace a new dimension in accuracy and picture quality.

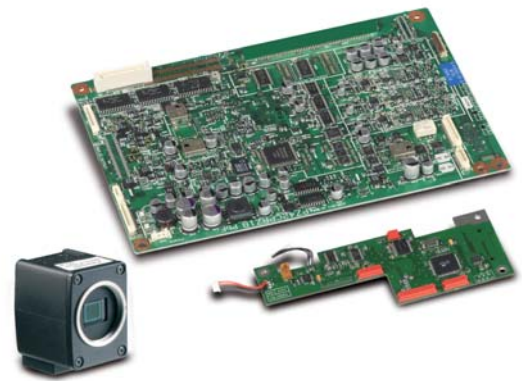

## Features

- Excellent price/performance ratio
- Technical data comparable with GP-US742
- Compact 1/3" 3CCD camera head, interlaced scan

Flexible universal control unit:

- Custom on-screen menu, 3-button control possible
- Programmable outputs for additional functions
- Programmable 3 x 8 keyboard matrix

## Block diagram of an OEM camera

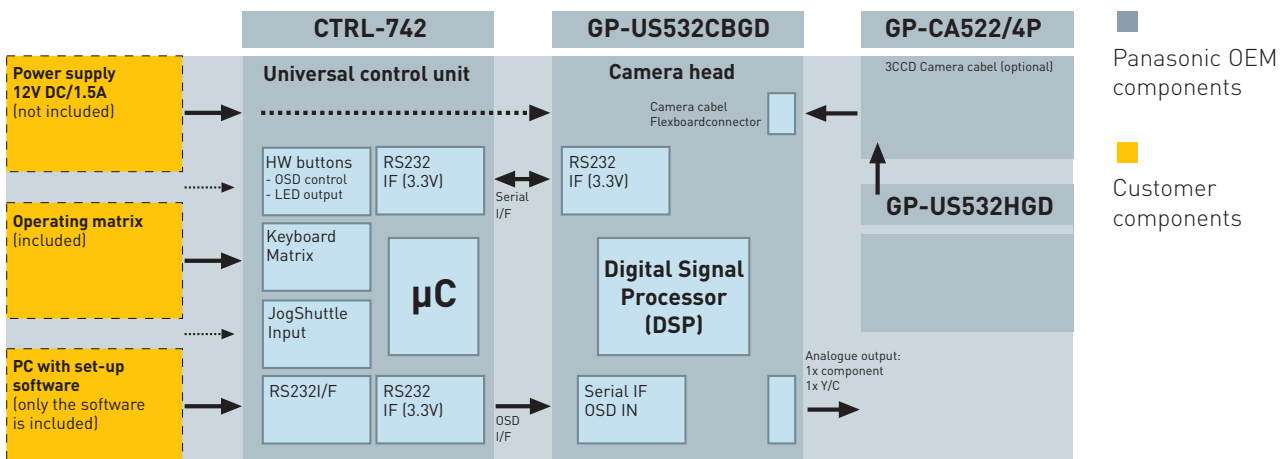

## System components



- GP-US532CBGD** CCU circuit board
- OEM version without casing
  - Controllable via RS-232C interface
  - Supports 1/3" 3CCD camera head
  - Dimensions (H x W x D): 140 x 20 x 200 mm



- GP-US532HGD** 3CCD camera head
- Delivered in casing
  - Interlace scan sensor
  - Resolution: 750 TV lines
  - 62 dB S/N ratio
  - C-mount lens connection
  - Dimensions (H x W x D): 34 x 44 x 52 mm

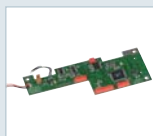

- CTRL-742** daughterboard
- OEM daughterboard
  - Keyboard matrix input
  - Jog-Shuttle input (optional)
  - 4 digital outputs (e.g. LED control)
  - Custom OSD possible
  - RS-232C interface



- GP-CA522/4** industrial signal cable
- Standard model
  - not suitable for medical use



The compact components of this camera system pack a powerful punch for the most diverse applications.

Panasonic's GP-KS822CU control unit and the GP-KS822H cable-linked camera head deliver outstanding precision on the smallest scale.

## Mini format – max performance

Capture images that would otherwise remain hidden. This system's cable-linked camera head, weighing in at just 14 g with a diameter of 17 mm, allows you to take precision shots, even in the most hard-to-reach places. The technical heart of the system, the control unit, is also a flyweight: the various functions are reliably controlled from the compact 530 g device.

## Accurate colours in any light

The camera system breaks images down into 480 lines. In artificial or natural light, the white balance ensures that the lighting does not influence colour reproduction. WB can be performed manually or at the press of a button.

## Flexible photometry

You can choose between different photometry ranges to make adjustments to varying light conditions. The CCD's exposure to light is continually monitored to ensure that the video signal remains as constant as possible.

## Features at a glance

- High resolution: latest 1/2" CCD chip with 752 x 582 pixels in PAL
- Minimum illumination: just 6 Lux at F1.4
- Operating temperatures of -10° C to +45° C and humidity levels of 30 % to 85 %
- Two cable lengths: 2 m and 3.8 m
- S-Video and two FBAS outputs on control unit

## Turn and rotate to your heart's content

The camera system's mirror and rotation function allows you to examine and observe images better than ever. For example, you can manipulate images captured with the camera head as a mirror or rotation image to make it easier to observe on the connected monitor. Freeze-frame can also be activated at the press of a button, allowing you to examine the finer details at your leisure.

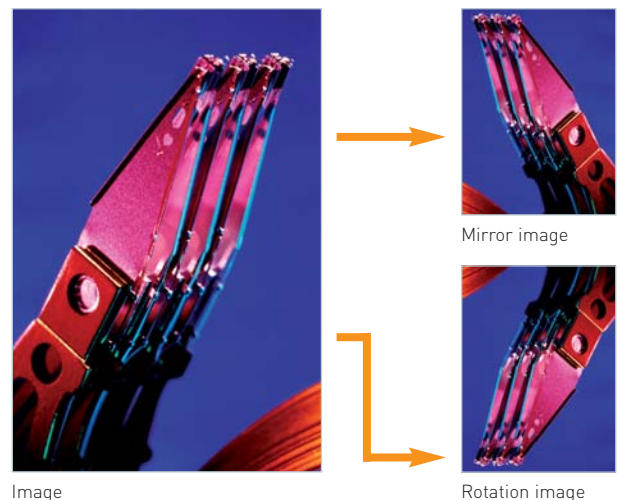

Image

Rotation image

Images can be rotated to the desired position.



Features such as the practical mirror and rotation function of Panasonic's 1CCD series are now also available for OEM components.

## Features

- Optimum integration thanks to compact design
- Lightweight: camera head is just 14 g and control unit 530 g
- Easy control of versatile functions



## Overview of controls and connections

### Front view:

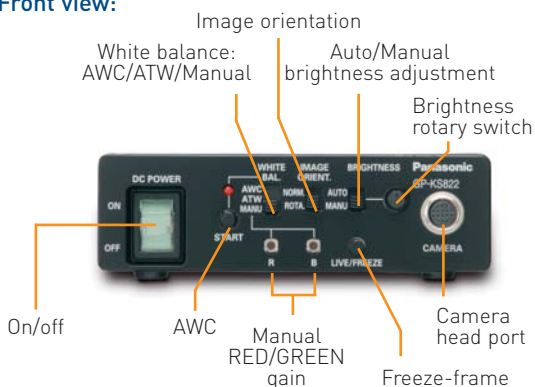

### Rear view:

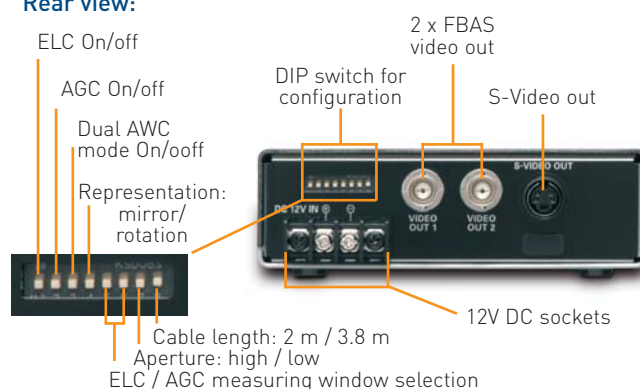

## System components



- GP-KS822CUE** control unit
- Standard version with casing
  - Supports 1/2" 1CCD camera head
  - Analogue outputs: 2 x FBAS, 1 x Y/C
  - Supports 2 m and 3.8 m camera cable
  - Dimensions (W x H x D): 120 x 36 x 157 mm



- GP-KS822HE** 1CCD camera head
- Standard version with casing
  - Interlace scan sensor
  - Resolution: 480 TV lines
  - 50 dB S/N ratio
  - Special lens connection (C-mount via adapter)
  - 17 (Ø) x 35.5 (L) mm



- GP-CA162/2** 2 m signal cable  
**GP-CA162/38** 3.8 m signal cable



- Optional lenses:  
**GP-LM3TAP** 3 mm lens  
**GP-LM7TAP** 7 mm lens  
**GP-LM15TAP** 15 mm lens  
**GP-LM24TAP** 24 mm lens



- GP-AD22TAP** C-mount adapter



- GP-KS822CBZE** circuit board
- OEM version without casing
  - Controllable via RS-232C interface
  - Supports 1/2" and 1/4" 1CCD camera head
  - Supports 2.5 m and 3.2 m camera cable
  - Analogue outputs: 2 x FBAS, 1 x Y/C
  - Dimensions (W x H x D): 75 x 20 x 139 mm



- GP-KS822HJZE** 1CCD camera head
- In casing, but without IR or LP filters
  - Interlace scan sensor
  - Resolution: 480 TV lines
  - 50 dB S/N ratio
  - Special lens connection (C-mount via adapter)
  - 17 (Ø) x 35.5 (L) mm

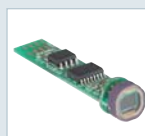

- GP-US842HZE** 1CCD camera head
- OEM version without casing
  - Interlace scan IT sensor
  - Resolution: 480 TV lines
  - 50 dB S/N ratio
  - 8 (Ø) x 37 (L) mm



- GP-NT12** external mains adapter (see GP-US742)

## Specifications

TV standard	PAL					16:9 HDTV, 60 Hz
Model name	Control unit	GP-US742CUE / GP-US532CBGD				GP-US932CUT
	Camera head	GP-US522HBE	GP-US732HE	GP-US532HGD [Z-E1015-02]	GP-US742HWE Modul	GP-US932HT
Image capture system	1/2" 3CCD		1/3" 3CCD	1/3" 3CCD	1/4" 3CCD	1/3" 3CCD
Pixels	752 x 582 pixels		753 x 582 pixels	753 x 582 pixels	753 x 582 pixels	---
Synchronisation	Internal or external (Genlock): automatically switchable -Internal to CCIR standard -External (Genlock) input: VBS, VS, HD/VD -SC phase for Genlock (VBS): adjustable -H phase for Genlock (VBS, VS): adjustable					Internal or external via SYNC
Video out	Video	2 x FBAS with 1 Vss / 75 Ohm				FBAS with 1 Vss / 75 Ohm
	S-Video (Y/C)	Y: 0.7 Vss Luminance level (Y)/75 Ohm / C: 0.3 Vss burst level (C)/75 Ohm				Y: 0.714 Vss Luminance level (Y)/75 Ohm; C: 0.286 Vss burst level (C)/75 Ohm
	RGB / YPbPr	R,G,B: 0.7 V each /75 Ohm Y: 0.7 Vss Luminance level/75 Ohm PbPr: 0.525 Vss/75 Ohm SYNC: 0.3 Vss sync level/75 Ohm				In either HD or SD format
	SDI (Digital)	---				2 x HD-SDI/SD-SDI
Required illumination	2000 Lux at F16, 3200 K	Interlaced scan: 2000 Lux at F13, 3200 K Progressive scan: 2000 Lux at F9, 3200K	2000 Lux at F8, 3200 K	Interlaced scan: 2000 Lux at F13, 3200 K Progressive scan: 2000 Lux at F9, 3200 K	2000 Lux at F5,6; 3200 K	
Minimum illumination	5 Lux at F2.8 with 12 dB gain without Sense-Up, 30 IRE level	Interlaced scan: 7 Lux at F2.8 with 12 dB gain without Sense-Up, 30 IRE level Progressive scan: 14 Lux at F2.8 with 18 dB gain, 30 IRE level	Interlaced scan: 7 Lux at F2.8 with 12 dB gain without Sense-Up, 30 IRE level Progressive scan: 14 Lux at F2.8 with 18 dB gain, 30 IRE level	Interlaced scan: 7 Lux at F2.8 with 12 dB gain without Sense-Up, 30 IRE level Progressive scan: 14 Lux at F2.8 with 18 dB gain, 30 IRE level	---	
Signal-to-noise ratio	62 dB (typical)				60 dB (typical)	54 dB (typical)
Horizontal resolution/ Pixel format	800 lines at centre of image (Y-Signal)	750 lines at centre of image (Y-Signal)	750 lines at centre of image (Y-Signal)	700 lines at centre of image (Y-Signal)	1080i: 1920 x 1080 pixels 720p: 1280 x 720 pixels 480i/p: 720 x 480 pixels	
White balance	ATW (Auto Tracing White Balance), AWC (Automatic White Balance Control) and Manual					
Black balance	ABC (Automatic Black Balance Control) and Manual				Automatic	
Colour bars	EBU colour bar with 0 % set-up				SMPTe colour bar with 7.5 % set-up	
Electronic shutter	AUTO: 1/50 to 1/10,000 sec. STEP: Selectable 1/50 (OFF), 1/120, 1/250, 1/500, 1/1,000, 1/2,000, 1/4,000, 1/10,000					
Gain Selection	AGC and Gain-up (selectable)					
CCU box switch	Red/blue Gain (white balance), for brightness level and ZOOM					
CCU box computer interface	RS232C with 1x D-SUB 9-pin connector					
Lens mount	Special C-mount	C-mount	C-mount	None	C-mount	
Power supply	12 V DC (sockets)				12 V DV HR10A-7P-4S(73) socket	
Power consumption	12 W				Less than 1.5 A / 12 V DC	
Ambient operating temperature	0°C to +45°C				0°C to +40°C	
Ambient operating humidity	30 % to 90 %				30 % to 85 %	
Dimensions (Height x Width x Depth)	Camera head (without mounting)	34 mm x 44 mm x 52 mm	34 mm x 44 mm x 52 mm	34 mm x 44 mm x 52 mm	Ø 34 mm x 90 mm	37 mm x 47 mm x 60 mm
	Control unit (without rubber feet and connectors)	GP-US742CUE: 170 mm x 44 mm x 227 mm GP-US532CBGD: 140 mm x 20 mm x 200 mm				170 mm x 44 mm x 229 mm
Weight	Camera head (without lens)	approx. 110 g			Less than 50 g	approx. 143 g
	Control unit	GP-US742CUE: approx. 1.2 kg				approx. 1.2 kg

### GP-US742 micro camera block diagram

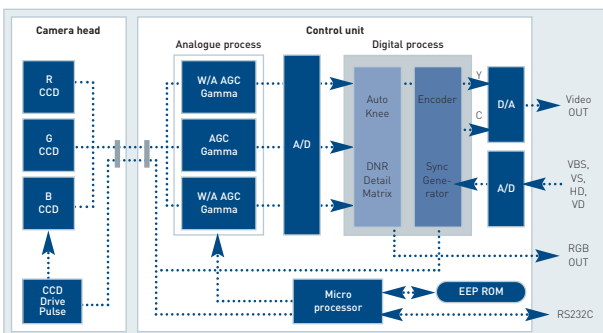

### GP-US742 system structure

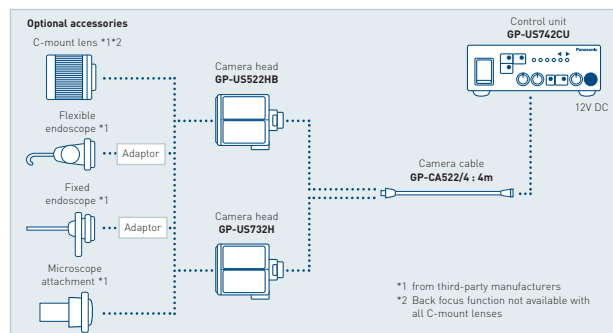

## Specifications

TV standard		PAL	
Modelname	Control unit	GP-KS822CUE /GP-KS822CBZE	
	Camera head	GP-KS822HE /GP KS822HJZE	GP-KS842HZE
Image capture system		1/2" Interline Transfer CCDs	1/4" Interline Transfer CCDs
Pixels		752 x 582 pixels	
Synchronisation		Internal	
Video out	Video 1.2	FBAS with 1 Vss / 75 Ohm	
	S-Video (Y/C)	Y: 0.7 Vss luminance level (Y)/750hm / C: 0.3 Vss burst level (C)/750hm	
Minimum illumination		6 Lux at F1.4	3 Lux at F1.4
Signal-to-noise ratio		Greater than 50 dB for luminance signal where AGC=OFF	
Horizontal resolution		Greater than 480 lines at centre of image (Y-Signal)	
White balance		ATW (Auto Trace White Balance), AWC (Automatic White Balance Control) and Manual	
Electronic shutter		AUTO: ON/OFF	
Gain selection		AGC: ON/OFF	
Switch		Rotary switch for red/blue gain (white balance) and for brightness control	
Lens mount		Optional: C-mount adapter or special lens	---
Power supply		12 V DC	
Power consumption		Less than 450 mA (12 V DC)	
Ambient operating temperature		-10°C to +45°C	
Ambient operating humidity		30% to 85%	
Dimensions	Camera head (ø x length) (without mounting)	ø 17 mm x 35.5 mm	ø (Max) 9 mm x 37 mm
	Control unit (Width x Depth x Height)	GP-KS822CUE without feet: 120 mm x 157 mm x 36 mm; GP-KS822CBZE: 75 mm x 139 mm x 19 mm	
Weight	Camera head (without lens)	ø 17 mm x 35.5 g	ø (max) 9 mm x 37 g
	Control unit	GP-KS822CUE: approx. 530 g	GP-KS822CBZE: approx. 50 g

Notes: 1) GP-KS822CBZE without ATW function

### GP-KS822 micro camera block diagram

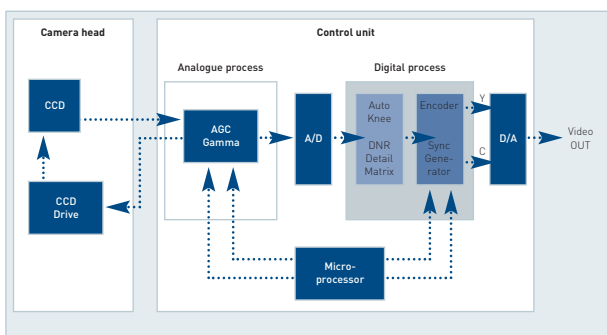

### GP-KS822 system structure

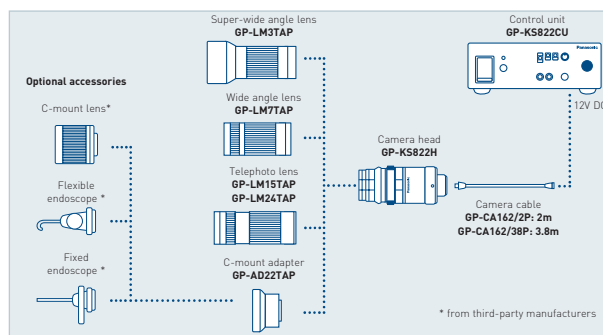

---

## Want to know more?

We would be happy to send you further information about Panasonic's CCD micro cameras.  
Simply call us on +44 (0)1344 853940

Information also available online: [www.medicalvision.panasonic.eu](http://www.medicalvision.panasonic.eu)

**Panasonic**  
ideas for life

Panasonic System Solutions Europe  
Panasonic House  
Willoughby Rd  
Bracknell  
RG12 8FP  
Phone: +44 (0)1344 853940  
Fax: +44 (0)1344 853221