

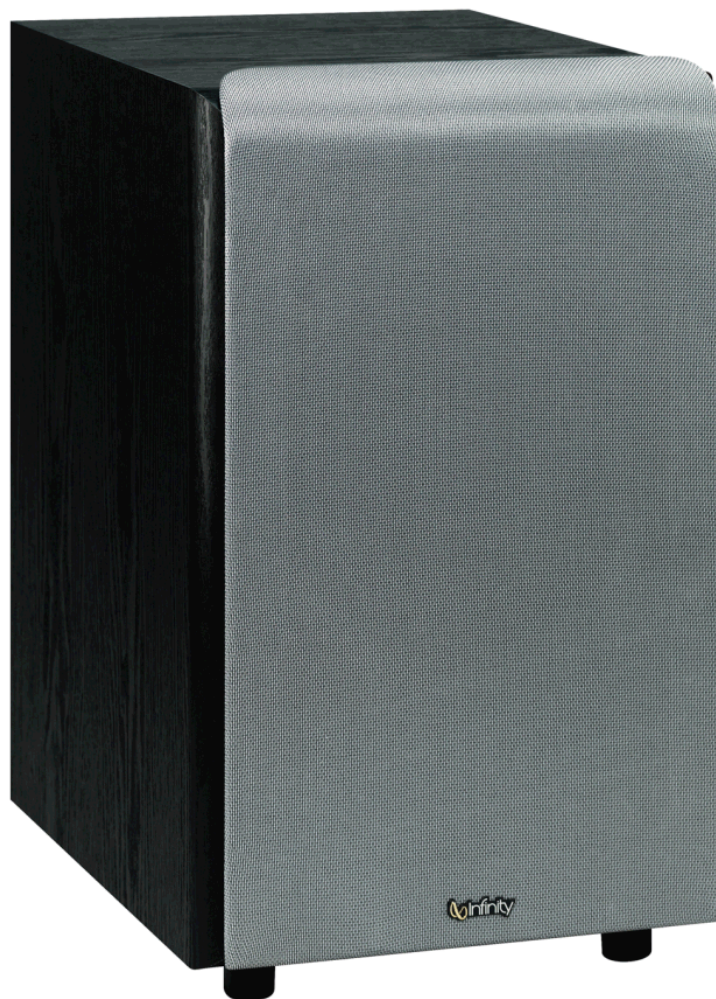

PS Series

PS28 Subwoofer

SERVICE MANUAL



Infinity Systems, Inc.
250 Crossways Park Dr.
Woodbury, New York 11797

Rev1 3/2007

- CONTENTS -

BASIC SPECIFICATIONS	1
DETAILED SPECIFICATIONS.....	2
PACKAGING.....	4
CONTROLS AND CONNECTIONS.....	5
OPERATION.....	7
EXPLODED VIEW/PARTS LIST	8
TEST SET UP AND PROCEDURE.....	9
BLOCK DIAGRAM.....	10
TROUBLESHOOTING FLOW CHART.....	12
ELECTRICAL PARTS LIST (120v)	13
PCB DRAWINGS.....	17
SEMICONDUCTOR PINOUTS.....	21
SCHEMATICS (120v).....	22

Basic Specifications PS28 Powered Subwoofer

Frequency Response:	35Hz – 150Hz (± 3 dB)
Maximum Amplifier Output:	150 Watts RMS (20Hz – 150Hz, with $\leq 0.1\%$ THD)
	300 Watts Peak
Crossover Frequency:	50Hz – 150Hz, 24dB/octave, continuously variable
Driver:	8" (200mm)
Dimensions (H x W x D):	17-7/8" x 10-5/8" x 16-1/2" (454mm x 270mm x 419mm)
Weight:	31.7 lb (14.4kg)

Infinity continually strives to update and improve existing products, as well as create new ones. The specifications and construction details in this and related Infinity publications are therefore subject to change without notice.

INFINITY PRIMUS PS28 150W Powered Sub/ Plate Amp					
LINE VOLTAGE	Yes/No	Hi/Lo Line	Unit	Notes	
US 120VAC/60Hz	Yes	108-132	Vrms	Normal Operation	
Europe 220-240VAC, 50-60Hz	Yes	220-230	Vrms	Normal Operation	
Parameter	Specification	Unit	QA Test Limits	Conditions	Notes
Amp Section					
Type (Class AB, D, other)	AB	AB	n/a	120V model	External Sink required for Class AB
Type (Class AB, D, other)	G	G	n/a	230V Model	
Rated Load Impedance	4	Ohms	n/a	Nominal	Impedance used for electrical measurements
System average impedance	8.79	Ohms	n/a	Average impedance from 10 to 500Hz	
Voice coil DCR	4.35	Ohms	n/a		Reference
Rated Output Power	100	Watts	95	Single input driven	
THD@ Rated Power	0.5	%	1	22K filter	
THD @ 1 Watt	0.1	%	0.3	22K filter	
DC Offset	10	mV-DC	50	@ Speaker Output	
Damping factor	>100		40		Measured at speaker terminals, Output power 90 Watts
Dynamic power RMS	125	Watts	Reference		AVG Power over the first 4 consecutive peaks, when tested with a burst signal 3/20 at 50 Hz
Highest RMS value	152	Watts	Reference		
Input Sensitivity					
Input Frequency	50	Hz	50	Nominal Freq.	
Line Input (L&R)	16.5	mVrms	±2dB	To 1W	Single input driven, AP Zo=600 Ohms
LFE Input	11.7	mVrms	±2dB	To 1W	LFE input driven only, AP Zo=600 Ohms
System Gain (Line input)	41	dB	±1dB	G=118	Single input driven, AP Zo=600 Ohms
System gain (LFE input)	44	dB	±1dB	G=165	LFE input driven only, AP Zo=600 Ohms
Signal to Noise					
SNR-A-Weighted	100	dB	85	rel. to rated power	A-Weighting filter
SNR-unweighted	85	dB	80	rel. to rated power	22K filter
SNR @ 1W-unweighted	65	dB	60	rel. to 1W Output	22K filter
Residual Noise Floor	1	mVrms(max)	1.5	Volume @max, w/ A/P Swept Bandpass Measurement (Line freq.+ harmonics)	
Input Impedance					
Line input L&R , LFE	>10	K ohms	n/a	Nominal	
Filters					
Low Pass (fixed or variable)	Variable	--	±2dB	Crossover range 50-150 Hz	
Subsonic filter (HPF)		Hz	±2dB	Fixed	
Limiters (yes/no)	YES	--	Functional		
THD at Max. Output Power	<1	%	Functional		
Features					
Line Level inputs (L&R)	YES		Functional		Dual RCA conenctor (RED-WHT)
LFE Input	YES		Functional		Single input (Yellow color)
Phase Switch (yes/no)	YES		Functional		
Volume pot Taper (lin/log)	LOG		Functional		
Variable crossover	YES		Functional		
ATO	YES		Functional		
LED indicator	YES		Functional		Located at the amplifier panel
Input Configuration					
Line In (L,R)	L ,R	--	Functional		RCA inputs: L , R Summed to Mono
Line level in LFE	LFE		Functional		
Signal Sensing (ATO)					
Auto-Turn-On (yes/no)	YES	--	Functional		
ATO Level @ 50 Hz	1	mV	Functional	One input driven	
ATO Level @ 1 KHz	1	mV	Functional	One input driven	
ATO Turn-on time	5	ms	Functional	Amp connected and AC on, then input signal applied	
Auto Mute/ Turn-OFF Time	10	minutes	Functional	T before muting, after signal is removed	Auto turn of time (T) must be 5 > T <15
Power on Delay time	3	sec.	Functional	AC Power Applied	
Transients/Pops					
ATO Transient	5	mV-peak	10	@ Speaker Outputs	
Turn-on Transient	50	mV-peak	100	@ Speaker Outputs	AC Line cycled from OFF to ON

Parameter	Specification	Unit	QA Test Limits	Conditions	Notes
Turn-off Transient	50	mV-peak	100	@ Speaker Outputs	AC Line cycled from ON to OFF
Efficiency					
Stand-by Input Power	12	Watts	15	@ nom. line voltage	Maximum allowable input power under nominal Input voltage and frequency, HOT or COLD operation.
Power Cons. @rated power	195	Watts	210	@ nom. line voltage	100 Watts @ 4 Ohms nominal line voltage
Protection					
Short Circuit Protection	YES	--	Functional	Direct short at output	
Thermal Protection	65 deg. C	--	Functional	@1/8 max unclipped Power	Temperature rise should not exceed 35K rise
DC Offset Protection	YES	--	Functional	DC present at Speaker Out leads	Relay or crowbar (for driver/fire protection)
Line Fuse Rating					External fuse with UL/SEMKO rated holder
120 VAC	2.5	Amps		Type-T or Slo Blo	
230 VAC	1.25	Amps		Type-T, Low breaking capacity	

PS28 PACKAGE

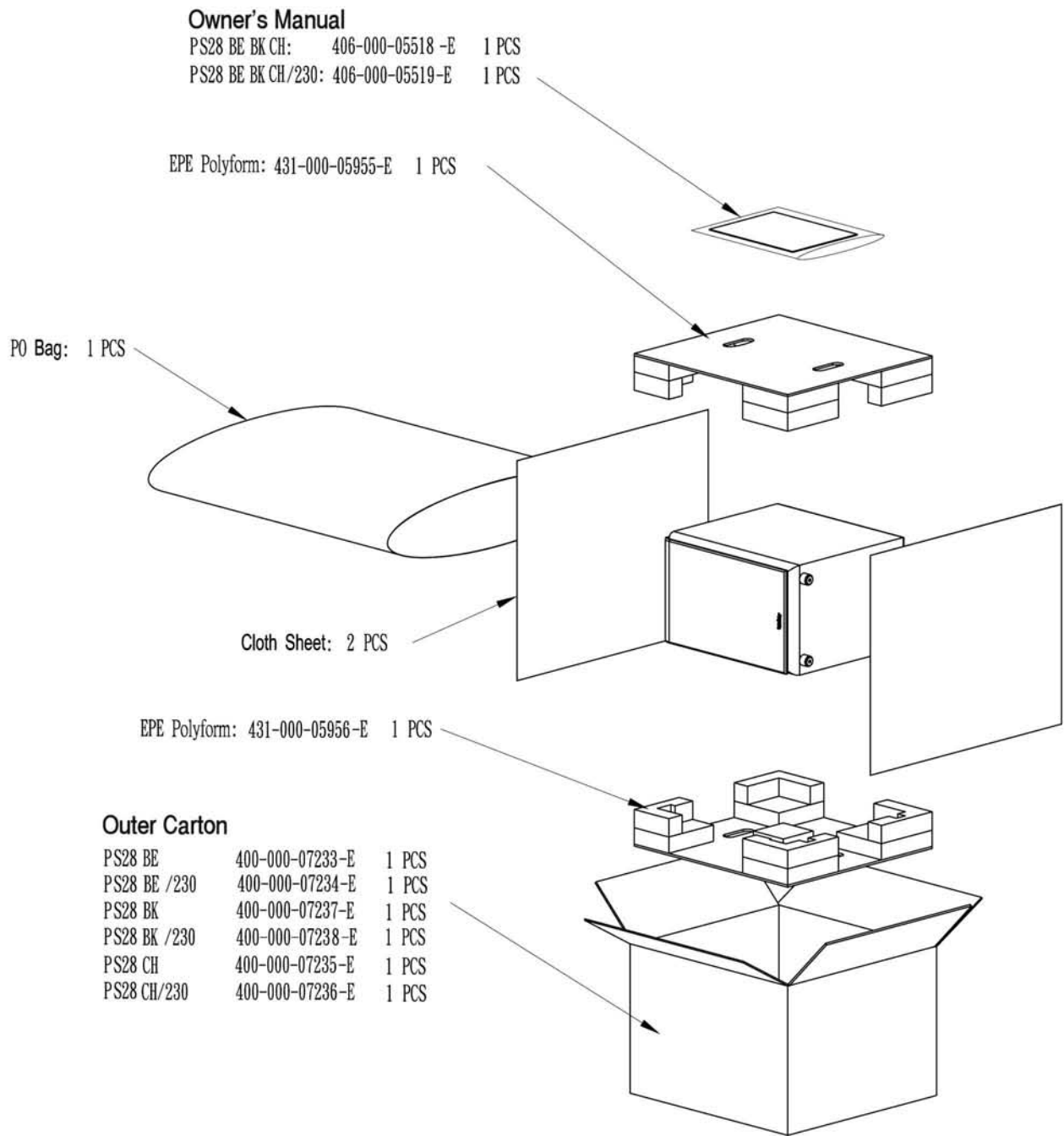

CONTROLS AND CONNECTIONS

Rear Panel

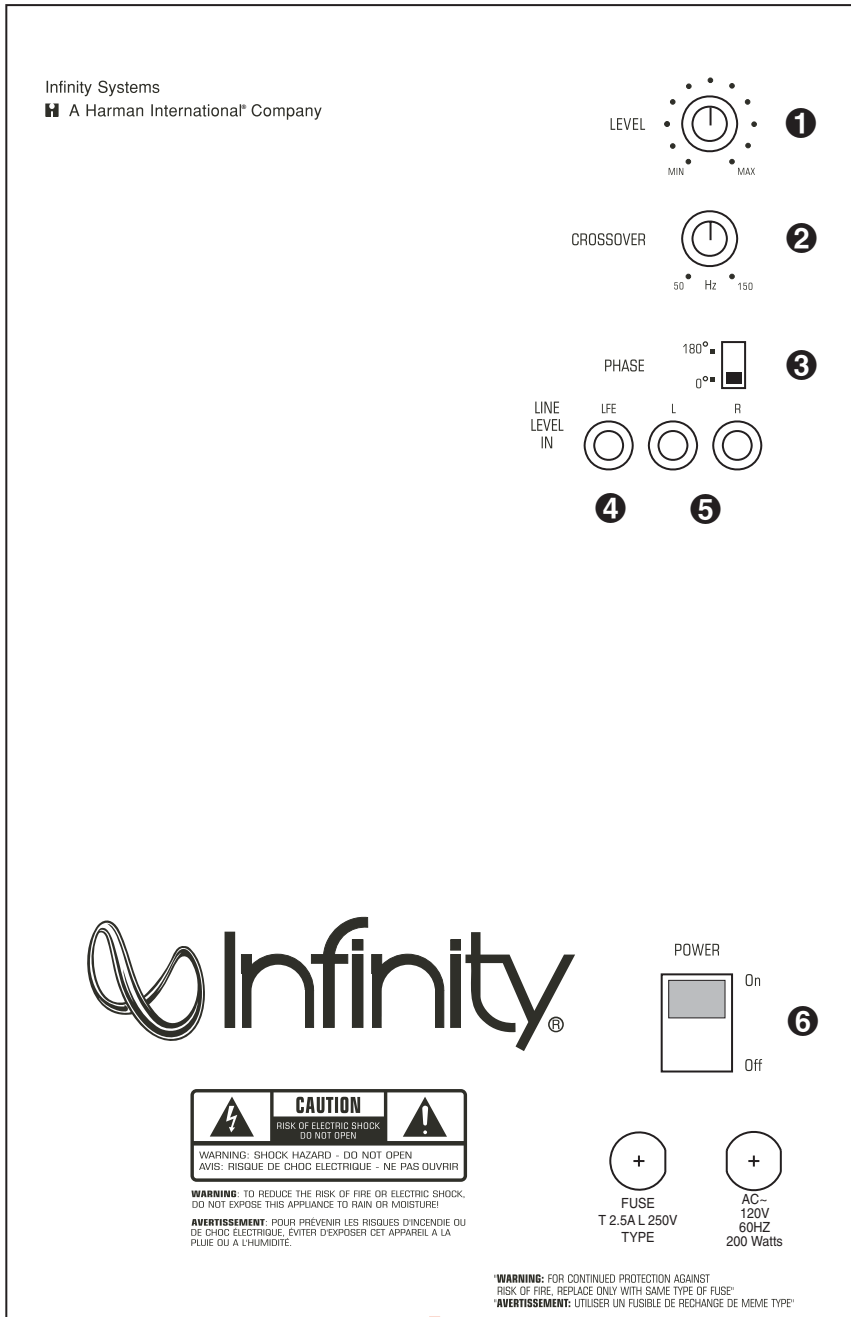

- 1 Subwoofer-Level Control
- 2 Crossover Adjustment
- 3 Phase Switch
- 4 LFE Input
- 5 Line-Level Inputs
- 6 Power Switch

SUBWOOFER CONNECTIONS

CHOOSE THE SUBWOOFER CONNECTION THAT IS MOST SUITABLE FOR YOUR RECEIVER/PROCESSOR

If you have a Dolby® Digital or DTS® receiver/processor with a low-frequency effects (LFE) or subwoofer output:

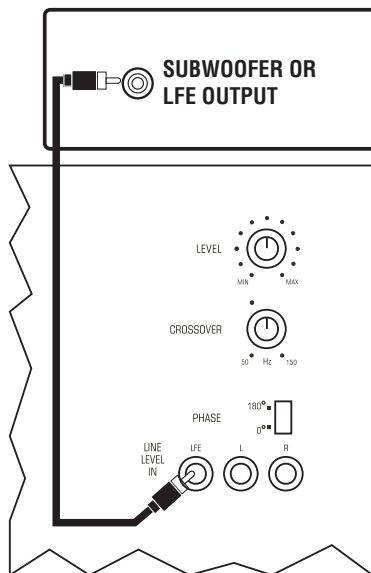

If your receiver/processor does not contain a Dolby Digital or DTS processor but has a subwoofer output:

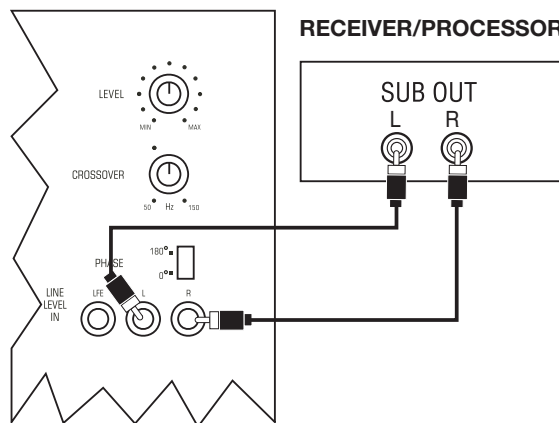

NOTE: Some receivers have one subwoofer output. In that case, it is recommended that you use a Y connector (not included) to maximize performance.

OPERATION

Power On

Plug your subwoofer's AC cord into a wall outlet. Do not use the outlets on the back of the receiver.

Initially set the Subwoofer-Level Control **1** to the "min" position.

Turn on your sub by pressing the Power Switch **6** on the rear panel. Turn on your entire audio system and start a CD or movie soundtrack at a moderate level.

Auto On/Standby

With the Power Switch **6** in the ON position, the LED on the rear panel will remain lit in red or green to indicate the On/Standby mode of the subwoofer.

RED = STANDBY (No signal detected, Amp Off)

GREEN = ON (Signal detected, Amp On)

The subwoofer will automatically enter the Standby mode after approximately 10 minutes when no signal is detected from your system. The subwoofer will then power ON instantly when a signal is detected. During periods of normal use, the Power Switch **6** can be left on. You may turn off the Power Switch **6** for extended periods of nonoperation, e.g., when you are away on vacation.

Adjust Level

Turn your Subwoofer-Level Control **1** up to the "5" position (halfway). If no sound emanates from the subwoofer, check the AC-line cord and input cables. Are the connectors on the cables making proper contact? Is the AC plug connected to a "live" receptacle? Has the Power Switch **6** been pressed to the "On" position? Once you have confirmed that the subwoofer is active, proceed by playing a CD, record or cassette. Use a selection that has ample bass information.

Set the overall volume control of the preamplifier or stereo to a comfortable level. Adjust the Subwoofer-Level Control **1** until you obtain a pleasing blend of bass. Bass response should not overpower the room but rather be adjusted so there is a harmonious blend across the entire musical range. Many users have a tendency to set the subwoofer volume too loud, adhering to the belief that a subwoofer is there to produce lots of bass. This is not entirely true. A subwoofer is there to enhance bass, extending the response of the entire system so the bass can be felt as well as heard. However, overall balance must be maintained or the music will not sound natural. An experienced listener will set the volume of the subwoofer so its impact on bass response is always there but never obtrusive.

Phase Control

The Phase Switch **3** determines whether the subwoofer speaker's piston-like action moves in and out with the main speaker's, 0°, or opposite the main speakers, 180°. Proper phase adjustment depends on several variables such as room size, subwoofer placement and listener position. Adjust the phase switch to maximize bass output at the listening position.

Crossover Adjustments

The Crossover Adjustment Control **2** determines the highest frequency at which the subwoofer reproduces sounds. If your main speakers can comfortably reproduce some low-frequency sounds, set this control to a lower frequency setting, between 50Hz and 100Hz. This will concentrate the subwoofer's efforts on the ultradeep bass sounds required by today's films and music. If you are using smaller bookshelf speakers that do not extend to the lower bass frequencies, set the Crossover Adjustment Control to a higher setting, between 120Hz and 150Hz.

NOTE: This control will have no effect if the LFE Input **4** is used. If you have a Dolby Digital or DTS processor/receiver, the Low-Pass Frequency is set by the processor/receiver. Consult your owner's manual to learn how to view or change this setting.

PS28 Exploded view

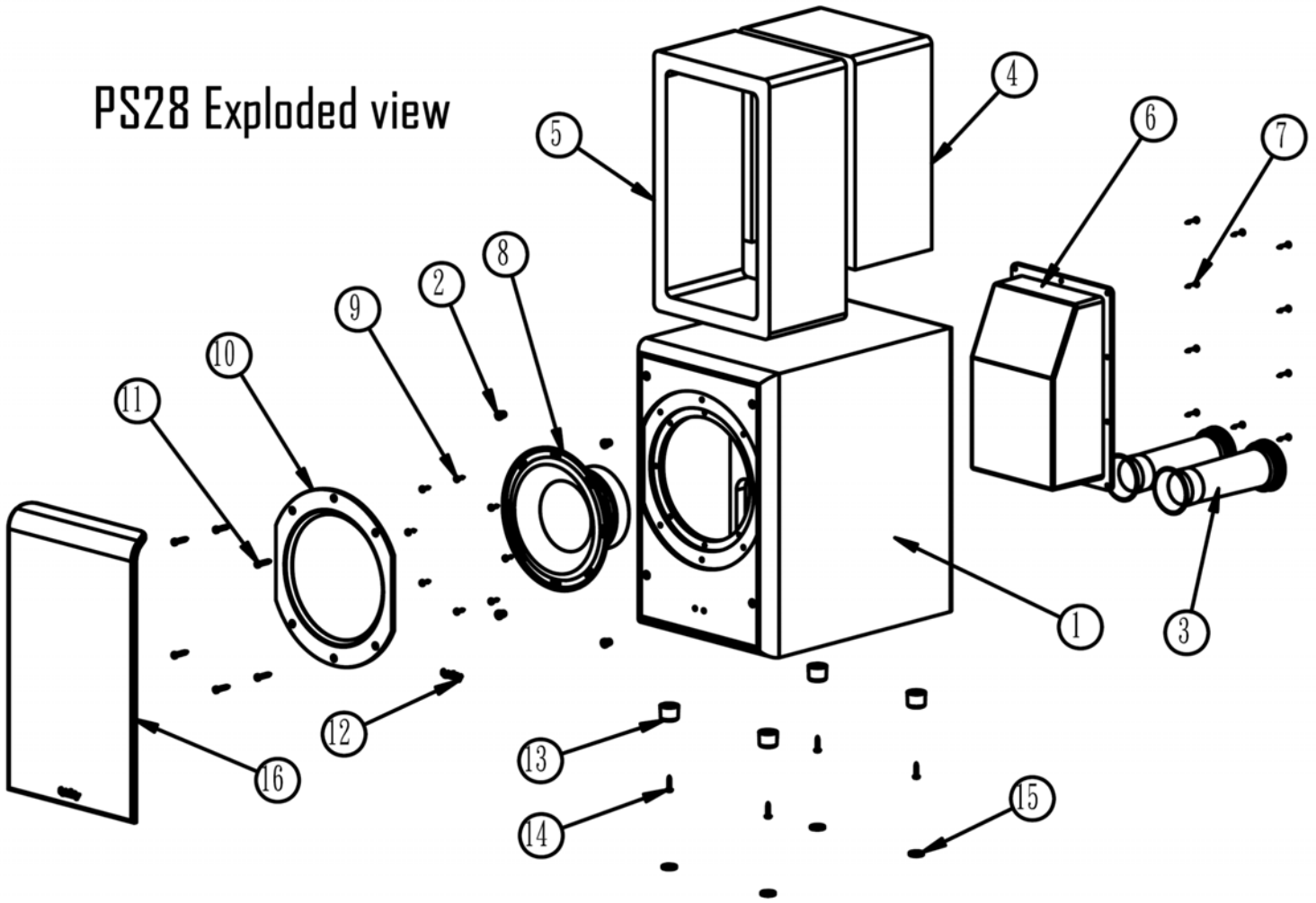

Item	Part name	Description	Q'ty
1	Not For Sale	PS28 ~ Cabinet	1
2	327-010-00624-E	Grille Cup	4
3	249HIPS-01003-0BAE	Port Tube	2
4	Not For Sale	Dacron (acoustic damping Material)	1
5	Not For Sale	Dacron (acoustic damping Material)	1
6	Not For Sale	PS28 ~ Amplifier	1
7	352-AM04020D210-E	Screw For Amplifier	10
8	20PR10DAG-FW06-E	8" Woofer	1
9	352-FM04014D609-E	Screw For 8" Woofer	8
10	213-080-00488-0VAE	8" Trim Ring	1
11	352-DM04525D597-E	Screw For 8" Trim ring	6
12	316-ABS-05218-0VAE	Infinity LOGO	1
13	320-ABS-00195-E	Plastic Foot	4
14	352-CM04025D604-E	Screw For plastic foot	4
15	320-RUB-00199-E	RUBBER foot	4
16	244-080-05226-0VAE	Grille	1

PS28 Test Set Up and Procedure

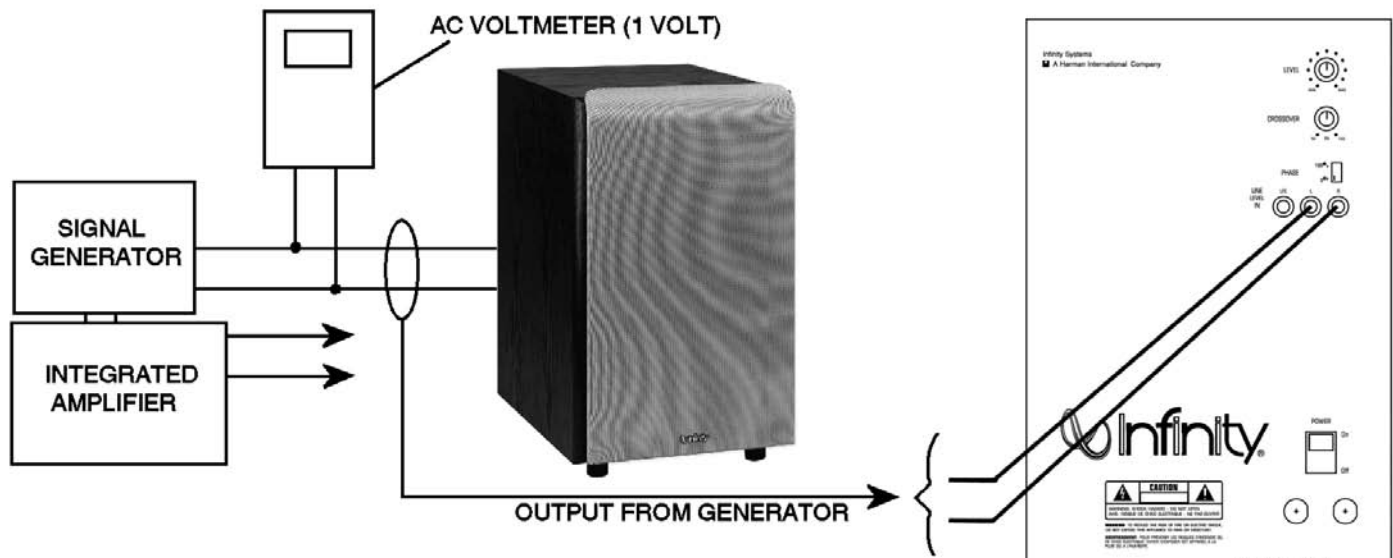

SYSTEM AURAL SWEEP TEST

Equipment needed:

- Function/signal generator/sweep generator
- Integrated Amplifier
- Multimeter
- Speaker cables

General Unit Function (UUT = Unit Under Test)

Switches/knobs on the amplifier faceplate:

Low Pass Frequency Adjust full CW (150Hz)

Phase switch – either position

1. From the signal generator, Connect both right and left line level inputs (RCA) – not the LFE jack - to signal generator and UUT. Use Y-cable if necessary from mono source.
2. On the amplifier, turn the LEVEL control full Counterclockwise (Min).
3. Turn on generator, adjust to **100mV, 50 Hz**.
4. Plug in UUT; turn the power switch ON. Turn LEVEL control full Clockwise (Max).
5. LED should now be Green; immediate bass response should be heard and felt from rear port tube opening.

Sweep Function

1. Follow steps 1-5 above, using a sweep generator as a signal source.
2. Sweep generator from 20Hz to 1kHz. Listen to the cabinet and drivers for any rattles, clicks, buzzes or any other noises. If any unusual noises are heard, remove woofer and test.

Driver Function (Woofer)

1. Remove woofer from cabinet; detach + and - wire clips.
2. Check DC resistance of woofer; it should be **4.4 ohms±10%**.
3. Connect a pair of speaker cables to driver terminals. Cables should be connected to an integrated amplifier fed by a signal generator. Turn on generator and adjust so that speaker level output is **5.0V**.
4. Sweep generator from 20Hz to 1kHz. Listen to driver for any rubbing, buzzing, or other unusual noises.

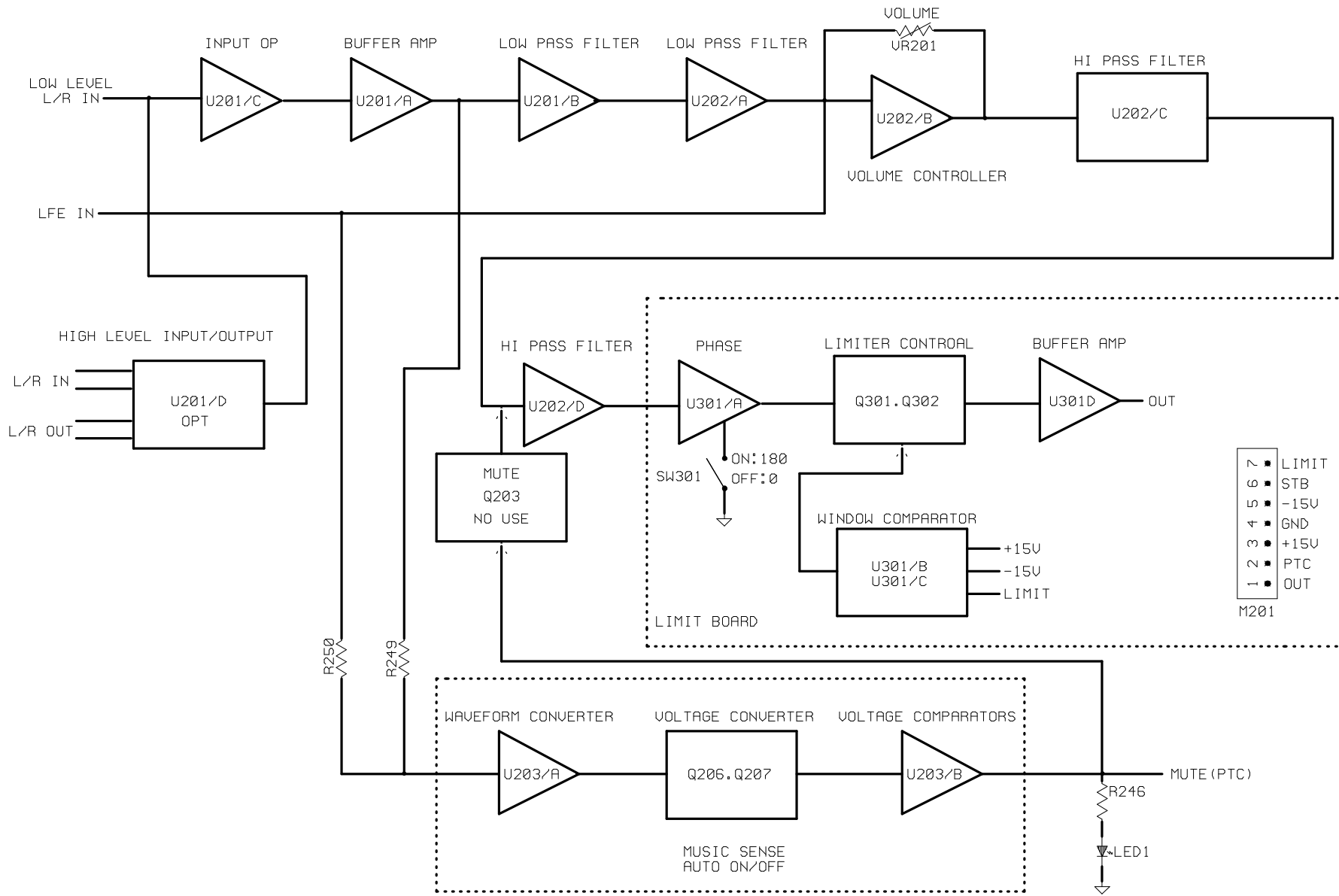

PS28 (UL) BLOCK DIAGRAM (PRE & LIMIT)

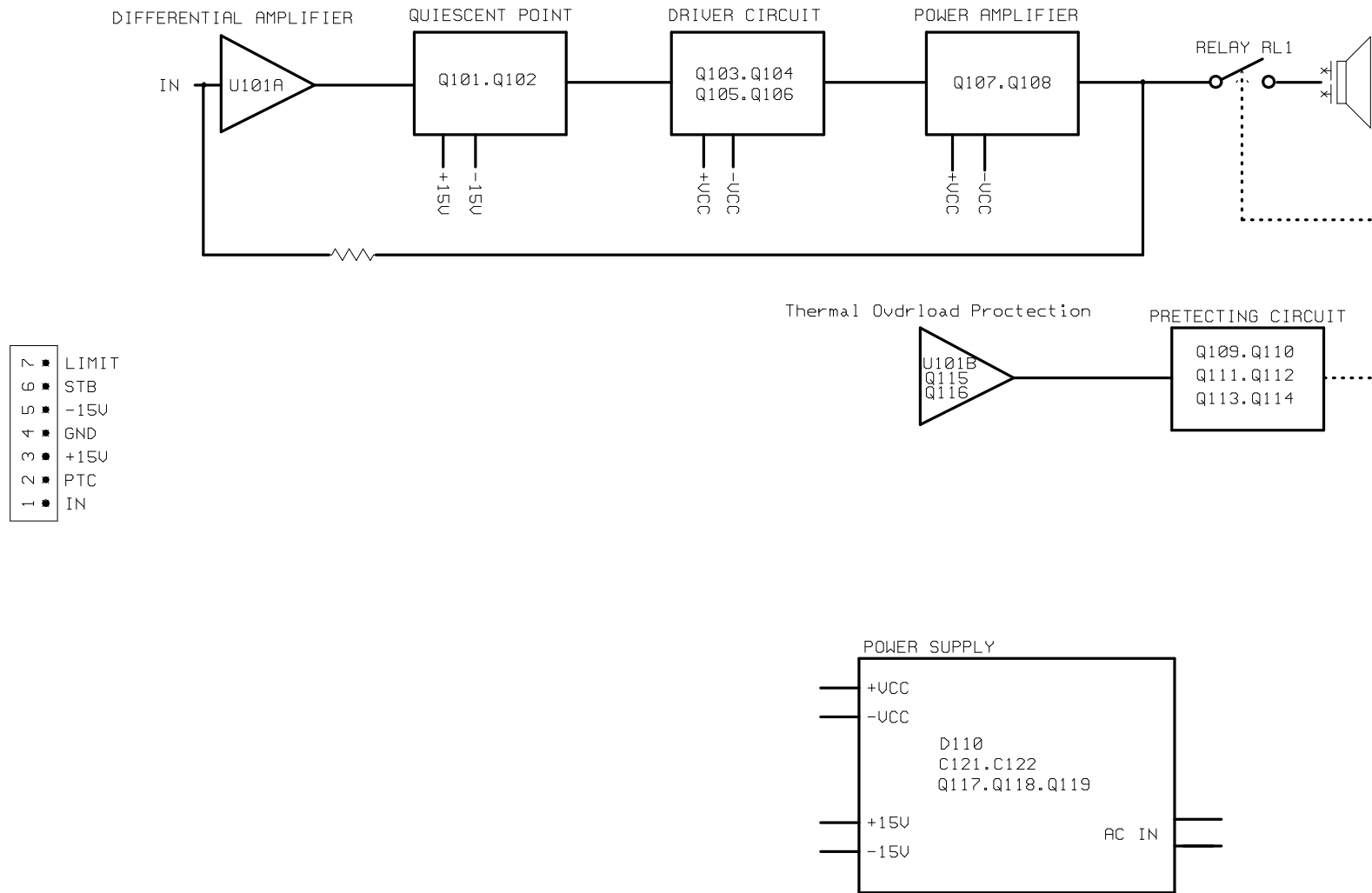

- | | |
|---|-------|
| 7 | LIMIT |
| 6 | STB |
| 5 | -15V |
| 4 | GND |
| 3 | +15V |
| 2 | PTC |
| 1 | IN |

PS28(UL) BLOCK DIAGRAM(POWER AMPLIFIER.POWER SOURCE.PRETECT)

PS28

Troubleshooting Flow Chart

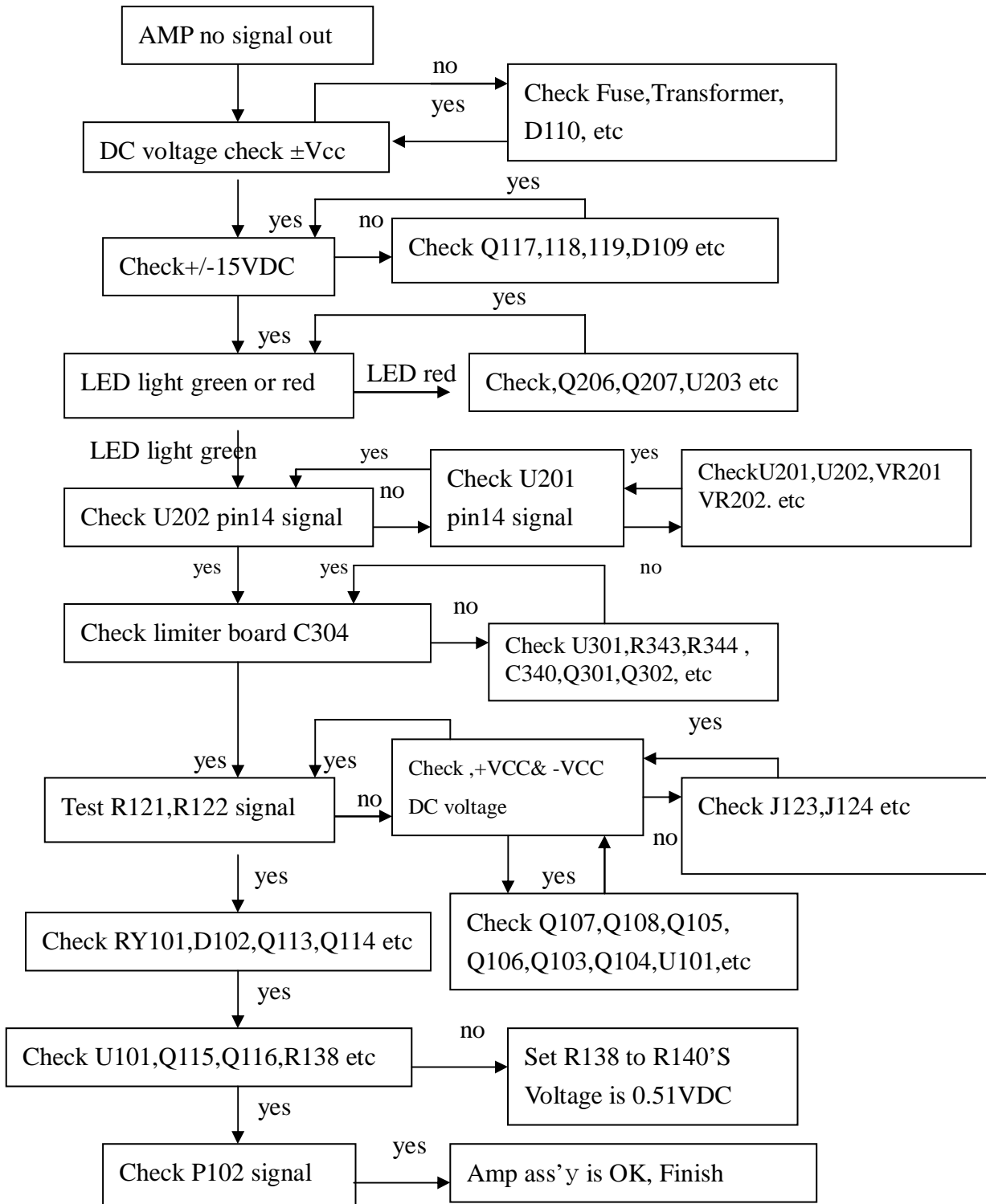

PS 28 (120v) Electrical Parts List			
Part Number	Description	Qty	Reference Designator
PREAMP PCB			
<i>Resistors</i>			
110-14122j26-e	Resistor 1.2K 1/4W ±5% CF 26mm (RoHS)	1	R270
110-16102j26-e	Resistor 1K 1/6W ±5% CF 26mm (RoHS)	5	R213,R214,R215,R254,R253
110-16103j26-e	Resistor 10K 1/6W ±5% CF 26mm (RoHS)	12	R212,R216,R217,R220,R221,R222,R225,R226,R228,R232,R235,R240
110-16104j26-e	Resistor 100K 1/6W ±5% CF 26mm (RoHS)	2	R231,R266
110-16105j26-e	Resistor 1M 1/6W ±5% CF 26mm (RoHS)	2	R259
110-16123j26-e	Resistor 12K 1/6W ±5% CF 26mm (RoHS)	1	R227
110-16183j26-e	Resistor 18K 1/6W ±5% CF 26mm (RoHS)	1	R262
110-16205j26-e	Resistor 2M 1/6W ±5% CF 26mm (RoHS)	1	R257
110-16223j26-e	Resistor 22K 1/6W ±5% CF 26mm (RoHS)	4	R238,R250,R255,R233
110-16224j26-e	Resistor 220K 1/6W ±5% CF 26mm (RoHS)	1	R251
110-16273j26-e	Resistor 27K 1/6W ±5% CF 26mm (RoHS)	1	R237
110-16333j26-e	Resistor 33K 1/6W ±5% CF 26mm (RoHS)	1	R249
110-16472j26-e	Resistor 4.7K 1/6W ±5% CF 26mm (RoHS)	4	R200,R207,R258,R260
110-16473j26-e	Resistor 47K 1/6W ±5% CF 26mm (RoHS)	1	R219
110-16474j26-e	Resistor 470K 1/6W ±5% CF 26mm (RoHS)	1	R252
110-16512j26-e	Resistor 5.1K 1/6W ±5% CF 26mm (RoHS)	3	R211,R229,R230
110-16562j26-e	Resistor 5.6K 1/6W ±5% CF 26mm (RoHS)	1	R224
116-164531f26-e	metal filmResistor 4.53K 1/6W ±1% MF26mm (RoHS)	1	R223
116-164991f26-e	metal filmResistor 4.99K 1/6W ±1% MF26mm (RoHS)	1	R234
115-h203b208-e	horizon variable Resistor B20K (RoHS) CROSSOVER	1	VR202,
115-h503a104-e	horizon variable Resistor D16 50K/1 A (RoHS) LEVEL	1	VR201,
<i>Capacitors</i>			
129-a224j633-e	metalize CAP. 0.22uF 63V ±5% MSC (RoHS)	1	C218
129-a564j633-e	metalize CAP. 0.56uF 63V ±5% (RoHS)	1	C216
130-2b221k503-e	disc capacitor 220P 50V ±10% (RoHS)	9	C207,C208,C210,C211,C212,C214,C220,C230,C249
130-3f104z503-e	disc capacitor 0.1U 50V +80/-20% (RoHS)	7	C232,C242,C244,C245,C246,C252,C254
130-ch220k503-e	disc capacitor 22PF CH 50V±10% (RoHS)	1	C229
130-2b220k503-e	disc capacitor22P 50V +/-10% (RoHS)	1	C229
132-103j503-e	Mylar capacitor 0.01uF 50V ±5% (RoHS)	2	C223,C224
132-104j503-e	Mylar capacitor 0.1U 50V ±5% (RoHS)	2	C215,C217
135-3105m50-e	electrolytic CAP. 1U 50V ±20% (RoHS)	1	C228
135-3106m50-e	electrolytic CAP. 10uF 50V ±20% (RoHS)	7	C206,C213,C231,C241,C243,C251,C253
135-3107m16-e	electrolytic CAP. 100uF 16V ±20% (RoHS)	2	C233,C234
135-3225m50-e	electrolytic CAP. 2.2U 50V ±20% (RoHS)	1	C219
135-3226m50-e	electrolytic CAP. 22U 50V ±20% (RoHS)	1	C225
129-a474j633-e	metalize capacitor 0.47U 63V ±5% MSC (RoHS)	2	C221,C222,
<i>Semiconductors</i>			
192-027c1815gr-e	transistor 2SC1815GR TOSHIBA (RoHS) NPN	2	Q206,Q207
197-031n4148-e	diode 100mA 75V SIGNAL 1N4148ROHM (RoHS)	7	D201,D202,D207,D208,D211,D212,D214
199-15000515-e	zener diode 5.1V 1/2W 52mm (RoHS)	1	D213
190-06m4558d-e	IC OPA 4558 DUAL OP-AMP	2	U101,U203,
190-16t1074cn-e	I.C TL074cm st QUAD OP-AMP	2	U201,U202,
195-10204hgw-e	double colors LED 204HWG 3C (RoHS)	1	LED1
<i>Miscellaneous</i>			
162-50259201-e	WIRE ASS'Y 2 PIN 250mm white/red(RoHS)	1	TO LED1,
174-0rca326p-e	JACK RCA-326 (RoHS)	1	JK202,
180-tms7210v-e	SWITCH SLIDE 6PIN MS7210V(RoHS) PHASE	1	SW301,
	JUMPER WIRE 26mm (RoHS)	30	ALL J,D215,D216

Part Number	Description	Qty	Reference Designator
POWER/MAIN PCB			
<i>Resistors</i>			
110-14472j26-e	Resistor 4.7K 1/4W ±5% CF 26mm (RoHS)	2	R147,R150
110-14681j26-e	Resistor 680Ω 1/4W ±5% CF 26mm (RoHS)	2	R148,R151
110-16101j26-e	Resistor 100Ω 1/6W ±5% CF 26mm (RoHS)	1	R120
110-16102j26-e	Resistor 1K 1/6W ±5% CF 26mm (RoHS)	1	R124
110-16103j26-e	Resistor 10K 1/6W ±5% CF 26mm (RoHS)	1	R134
110-16105j26-e	Resistor 1M 1/6W ±5% CF 26mm (RoHS)	1	R143
110-16123j26-e	Resistor 12K 1/6W ±5% CF 26mm (RoHS)	2	R135,R139
110-16152j26-e	Resistor 1.5K 1/6W ±5% CF 26mm (RoHS)	6	R103,R123,R136,R137,R141,R142
110-16153j26-e	Resistor 15K 1/6W ±5% CF 26mm (RoHS)	4	R118,R145,R152,R154
110-16154j26-e	Resistor 150K 1/6W ±5% CF 26mm (RoHS)	1	R131
110-16181j26-e	Resistor 180Ω 1/6W ±5% CF 26mm (RoHS)	2	R111,R114
110-16182j26-e	Resistor 1.8K 1/6W ±5% CF 26mm (RoHS)	1	R153
110-16223j26-e	Resistor 22K 1/6W ±5% CF 26mm (RoHS)	3	R128,R129,R133
110-16332j26-e	Resistor 3.3K 1/6W ±5% CF 26mm (RoHS)	3	R106,R107,R144
110-16392j26-e	Resistor 3.9K 1/6W ±5% CF 26mm (RoHS)	2	R105,R108
110-16393j26-e	Resistor 39K 1/6W ±5% CF 26mm (RoHS)	1	R126
110-16470j26-e	Resistor 47Ω 1/6W ±5% CF 26mm (RoHS)	4	R112,R113,R115,R116
110-16471j26-e	Resistor 470Ω 1/6W ±5% CF 26mm (RoHS)	1	R140
110-16472j26-e	Resistor 4.7K 1/6W ±5% CF 26mm (RoHS)	3	R110,R125,R130
110-16473j26-e	Resistor 47K 1/6W ±5% CF 26mm (RoHS)	1	R101
110-16560j26-e	Resistor 56Ω 1/6W ±5% CF 26mm (RoHS)	1	R117
110-16563j26-e	Resistor 56K 1/6W ±5% CF 26mm (RoHS)	1	R104
110-16682j26-e	Resistor 6.8K 1/6W ±5% CF 26mm(RoHS)	1	R109
110-10821jk2-e	Resistor 820Ω 1W ±5% 10mm (RoHS)	1	R132,
110-122r2j15-e	Resistor 2.2Ω 1/2W ±5% 15mm (RoHS)	1	R127,
110-20331jk2-e	Resistor 330Ω 2W ±5% 5mm (RoHS)	1	R146,
110-20331jk3-e	Resistor 330Ω 2W ±5% (RoHS)	1	R149,
113-50r10j10-e	cement Resistor 0.1Ω 5W ±5% (RoHS)	2	R121,R122,
114-03302m0-e	semi-fixed Resistor 3K 0.3W ±20% (RoHS)	1	R138,
<i>Capacitors</i>			
130-2b102k503-e	disc capacitor 1000P 50V ±10% (RoHS)	1	C116
130-3f104z503-e	disc capacitor 0.1U 50V +80/-20% (RoHS)	4	C108,C113,C115,C119
130-3f473m503-e	disc capacitor 0.047U 50V ±20% (RoHS)	1	C106
132-104j503-e	Mylar capacitor 0.1U 50V ±5% (RoHS)	1	C107
132-223ja03-e	Mylar capacitor 0.022uF 100V ±5% (RoHS)	4	C124,C125,C126,C128
135-3105m50-e	electrolytic CAP. 1U 50V ±20% (RoHS)	2	C105,C112
135-3107m16-e	electrolytic CAP. 100uF 16V ±20% (RoHS)	3	C109,C117,C120
135-3226m50-e	electrolytic CAP. 22U 50V ±20% (RoHS)	2	C114,C118
135-3227m10-e	electrolytic CAP. 220U 10V ±20% (RoHS)	2	C129,C130
135-3227m16-e	electrolytic CAP. 220U 16V ±20% (RoHS)	1	C111
135-3476m25-e	electrolytic CAP. 47U 25V ±20% (RoHS)	1	C103
132-223ja03-e	mylar capacitor 0.022uF 100V ±5% (RoHS)	2	C123,C127,
135-3107m16-e	electrolytic CAP. 100uF 16V ±20% (RoHS)	1	C110,
135-4688m50-e	electrolytic CAP. 6800U/50V ±20% D25X45mm (RoHS)	2	C121,C122,
<i>Semiconductors</i>			
192-027c1815gr-e	transistor 2SC1815GR TOSHIBA(RoHS)	7	Q102,Q111,Q112,Q113,Q118,Q114,Q116
192-1572n5551-e	transistor FSC 2N5551 (RoHS) NPN	2	Q103,Q109
192-1582n5401-e	transistor FSC 2N5401 AI-PNP 350V500mA TO-92 (RoHS)	2	Q104,Q110
197-031n4148-e	diode 100mA 75V SIGNAL 1N4148ROHM (RoHS)	6	D101,D103,D105,D108,D117,D118
199-15000335-e	zener diode 3.3V 1/2W 52mm (RoHS)	1	D102
199-15000625-e	zener diode HZ6C2 RENESAS (RoHS)	2	D106,D107
199-15001605-e	zener diode HZ16-2 RENESAS (RoHS)	1	D109
190-06m4558d-e	IC OPA 4558 DUAL OP-AMP	2	U101,U203,
192-021tip35c-e	transistor TIP35C (RoHS) NPN	1	Q107,
192-022tip36c-e	transistor TIP36C (RoHS) PNP	1	Q108,

Part Number	Description	Qty	Reference Designator
POWER/MAIN PCB			
192-027c1815gr-e	transistor 2SC1815GR TOSHIBA(RoHS) NPN	2	Q101,Q115,
192-201d882y-e	transistor KSD882Y (RoHS) PNP	1	Q117,
192-202b772y-e	transistor KSB772Y (RoHS) PNP	1	Q119,
192-991d669a-e	transistor HI-SINCERITY HSD669A (RoHS) NPN	1	Q106,
192-992b649t-e	transistor HSB649T (RoHS) PNP	1	Q105,
197-00kb1405-e	diode 4A 500V KBL405 (RoHS)	1	D110,
197-031n4148-e	diode 100mA 75V SIGNAL 1N4148 ROHM (RoHS)	1	D116,
197-101n4002-e	diode 1N4002TB (RoHS)	1	D104,
<i>Miscellaneous</i>			
171-udhss124d-e	relay 5A 24V UDH-SS124D (RoHS)	1	RY101,
175-1c07v01-e	wire connector & base 7PIN PITCH=2.5mm (RoHS)	1	P101,
175-1d02v01-e	wire connector & base 2PIN PITCH=3.96mm (RoHS)	1	P102,
175-1d03v01-e	wire connector & base 3 PIN PITCH=3.96mm JST-VH cut off the middle PIN (RoHS)	1	P103,
193-3m2520-e	insulator TO-3P 25x20mm (RoHS)	2	for Q107,Q108,
323-AL-00020-0LAE	HEAT SINK 65*32*31 AL	1	
351-AM03014A094-E	M3*14 machine screw black (RoHS)	1	
352-AM03008D040-E	Ø 3*8 B type ping screw black (RoHS)	4	
361-FE-00051-0LAE	transistor holder 14.2*8.0*5.2t=1.6mm (RoHS)	1	
361-NYL-00054-0LAE	transistor insulator pad (SW06002) (RoHS)	2	
362-FE-00041-0LAE	PCB support 11.75*8.5*12.5H(RoHS)	1	
LIMITER PCB			
<i>Resistors</i>			
110-16103j26-e	Resistor 10K 1/6W ±5% CF 26mm (RoHS)	1	back
116-161132f26-e	metal filmResistor 11.3K 1/6W ±1% MF 26mm (RoHS)	1	back
110-16103j26-e	Resistor 10K 1/6W ±5% CF 26mm (RoHS)	8	R301,R303,R304,R308,R309,R314,R340,R344
110-16183j26-e	Resistor 18K 1/6W ±5% CF 26mm (RoHS)	1	R302
110-16223j26-e	Resistor 22K 1/6W ±5% CF 26mm (RoHS)	2	R310,R312
110-16273j26-e	Resistor 27K 1/6W ±5% CF 26mm(RoHS)	1	R341
110-16333j26-e	Resistor 33K 1/6W ±5% CF 26mm(RoHS)	1	R305
110-16472j26-e	Resistor 4.7K 1/6W ±5% CF 26mm (RoHS)	2	R342,R343
110-16474j26-e	Resistor 470K 1/6W ±5% CF 26mm (RoHS)	1	R307
110-16751j26-e	Resistor 750Ω 1/6W ±5% CF 26mm(RoHS)	2	R311,R313
<i>Capacitors</i>			
130-3f104z503-e	disc capacitor 0.1U 50V +80/-20% (RoHS)	2	C305,C306
132-103j503-e	mylar capacitor 0.01uF 50V ±5% (RoHS)	2	C302,C303
135-3226m50-e	electrolytic CAP. 22U 50V ±20% (RoHS)	2	C301,C340
135-3476m25-e	electrolytic CAP. 47U 25V ±20% (RoHS)	1	C304
<i>Semiconductors</i>			
190-16ti074cn-e	I .C TL074cm st QUAD OP-AMP	1	U301,
197-031n4148-e	diode 100mA 75V SIGNAL 1N4148 ROHM (RoHS)	1	back
192-027c1815gr-e	transistor 2SC1815GR TOSHIBA (RoHS) NPN	2	Q301,Q302
197-031n4148-e	diode 100mA 75V SIGNAL 1N4148ROHM (RoHS)	2	D301,D302
<i>Miscellaneous</i>			
162-50289001-e	CABLE ASS'Y 280mm AWG26 WHT (RoHS)	1	
162-80098201-e	90mm 28AWG (RoHS)	1	to SW301,
175-9f40hr2-e	wire connector & base 40PIN PITCH=2.54mm HR2*40 (RoHS)		P301,

Part Number	Description	Qty	Reference Designator
MISCELLANEOUS/MECHANICAL			
123-14j70d-e	Ferrite Core U-16.3*8.2*13 (J70)+CASE (RoHS)	1	
130-3f472md00-e	disc capacitor 4700P 400V ± 20% safy long foot (RoHS)	1	
150-e8604107-e	transformer EI-86 60Hz 120V TT0869906580	1	T1
152-u602015-e	power line cord polar SVT FT-2 6FT double insulation (RoHS)	1	
154-u25006t0-e	fuse 2.5A 250V 20mm (RoHS)	1	FS101,
155-520020-e	fuse holder R3-11 (RoHS)	1	
162-10151001-e	WIRE UL1617 150mm 22AWG BROWN 6:6 (RoHS)	1	
162-50652003-e	WIRE 650mm RED=205# 0.5T BLK=110# 0.5T (RoHS)	1	
176-wjce1-e	wire connector pin CE-1 (RoHS)	1	
180-prf1003s-e	power switch ROCK RF-1003-BB2-OHA (RoHS)	1	SW100
302-AL-00406-1BDE	rear board 300*200*2.5T black (RoHS)	1	
306-ABS-00177-0BAE	rear housing 198*298*102mm (RoHS)	1	
311-ABS-00028-0BAE	knob CROSSOVER,LEVEL 46077-W P.V.C. (RoHS)	2	
320-RUB-00033-0BAE	rubber foot pad 25*21*4t (RoHS)	4	
323-AL-00106-0BBE	HEAT SINK 117.5*71.5*25 black (RoHS)	1	
333-EVA-00761-0BAE	Gasket 18*9*2T (RoHS)	1	
333-EVA-00783-0BAE	Gasket W 198*12*2.0T	2	
333-EVA-00807-0BAE	Gasket L 274*12*2.0T (RoHS)	2	
333-EVA-00826-0BAE	Gasket W 198*12*1.0T (RoHS)	2	
333-EVA-00835-0BAE	Gasket L 274*12*1.0T (RoHS)	2	
335-NYL-05015-0BAE	wire clip SB4F-2 black (RoHS)	2	
337-CU-00101-0LAE	metal foil 65L*50W (RoHS)	1	
350-EM04012D024-E	4 \varnothing *12 wood screw black (RoHS)	4	
351-AM03008A079-E	M3*8 machine screw black (RoHS)	7	
351-HM04016A218-E	M4*16 machine screw black(RoHS)	4	
352-AM03008D040-E	\varnothing 3*8 B type ping screw black (RoHS)	8	
352-AM03010D065-E	\varnothing 3*10 P type ping screw black(RoHS)	2	
354-GM04002-E	M4 screw cap adding pad black(RoHS)	4	
362-FE-00013-0LAE	PCB support L TYPE t=1.6mm S.P.C.C 89*9*1.6T (RoHS)	2	

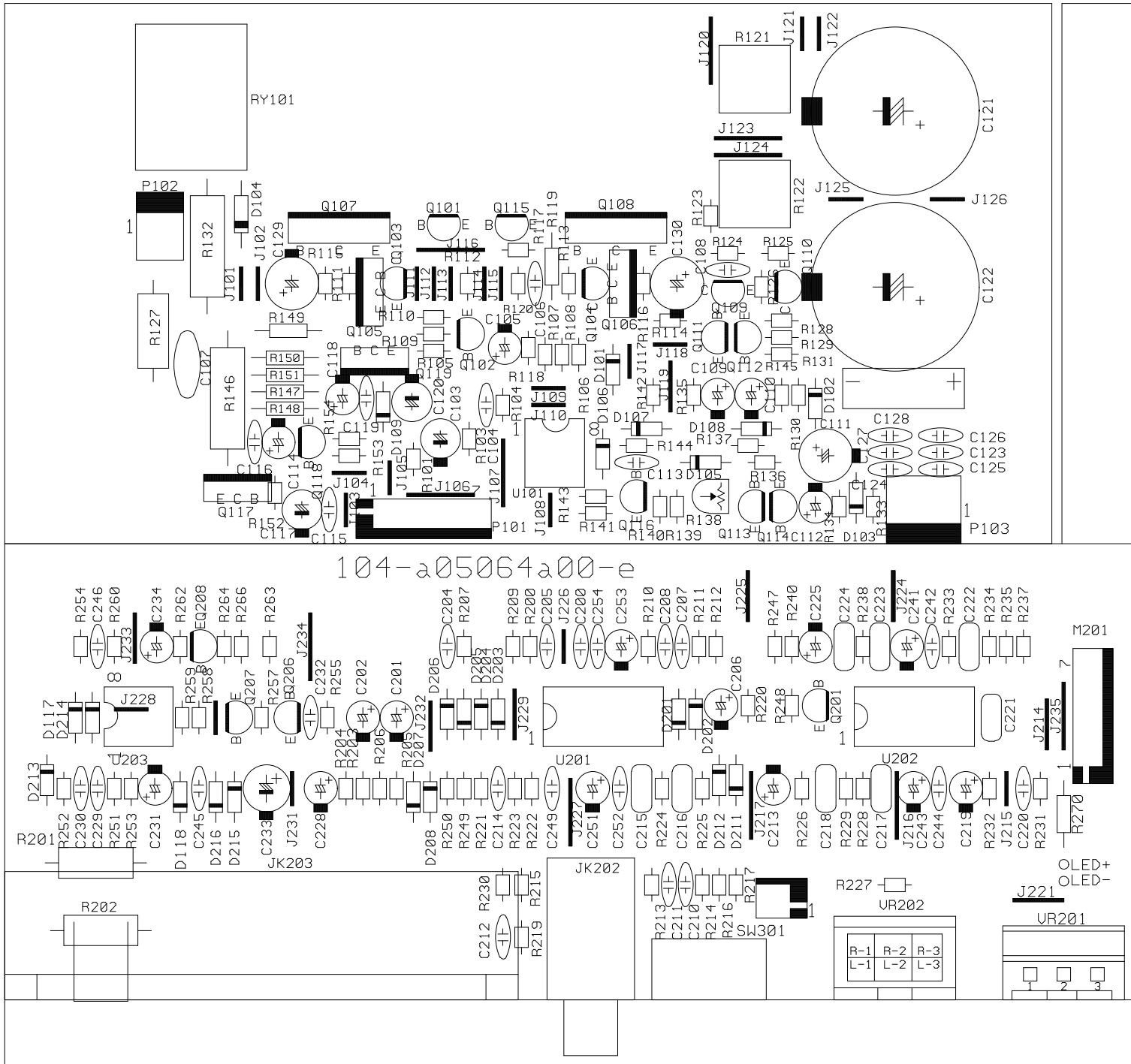

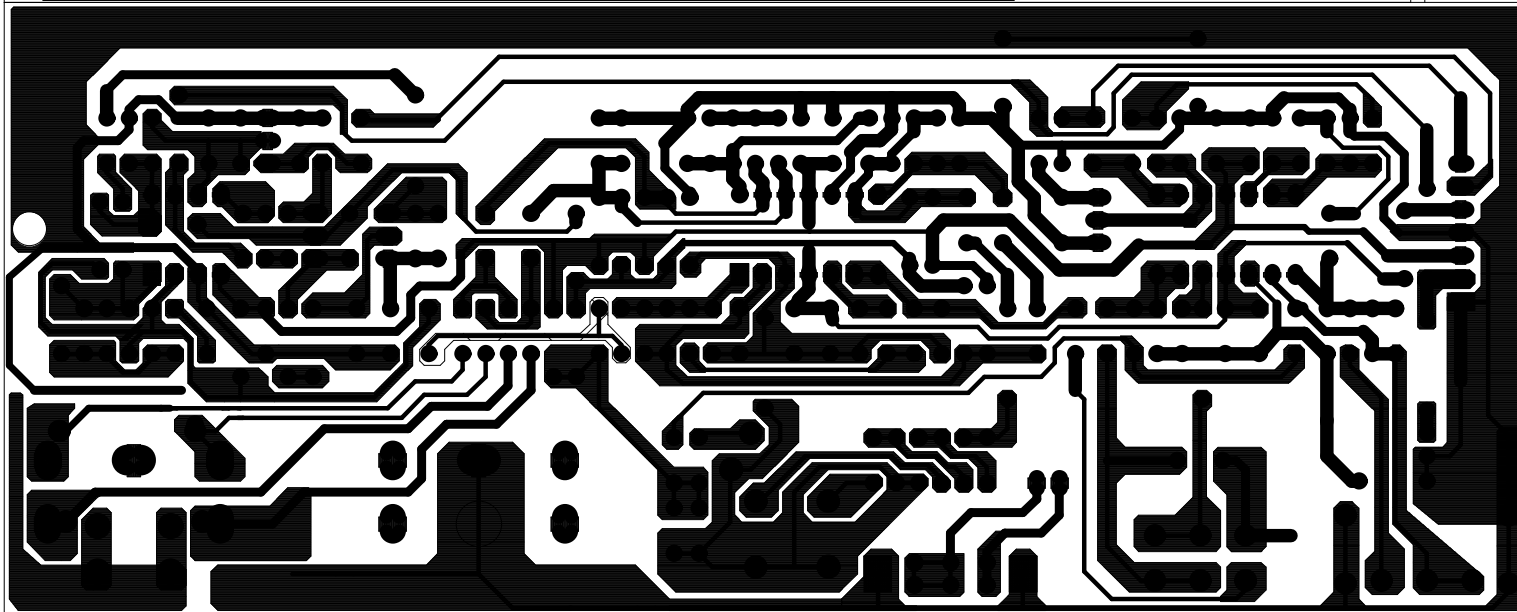
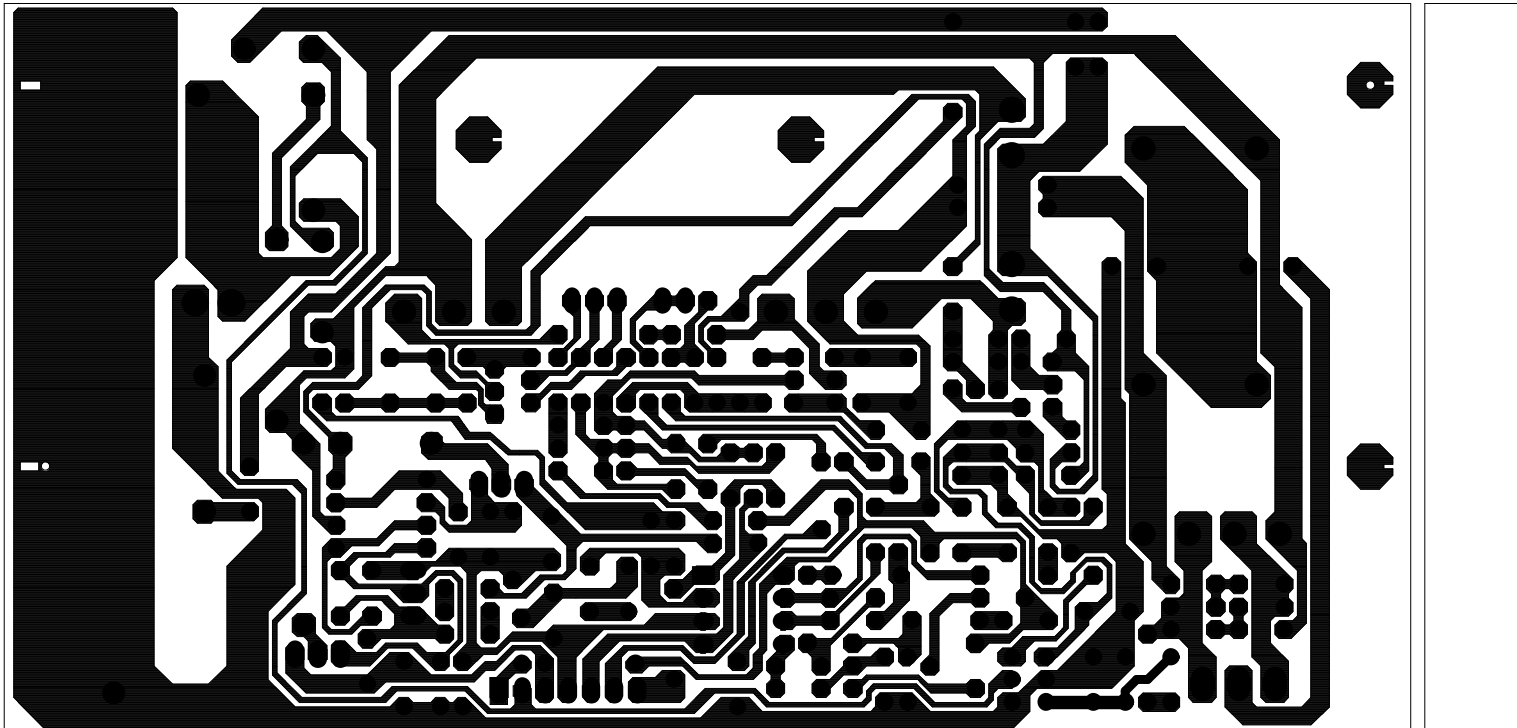

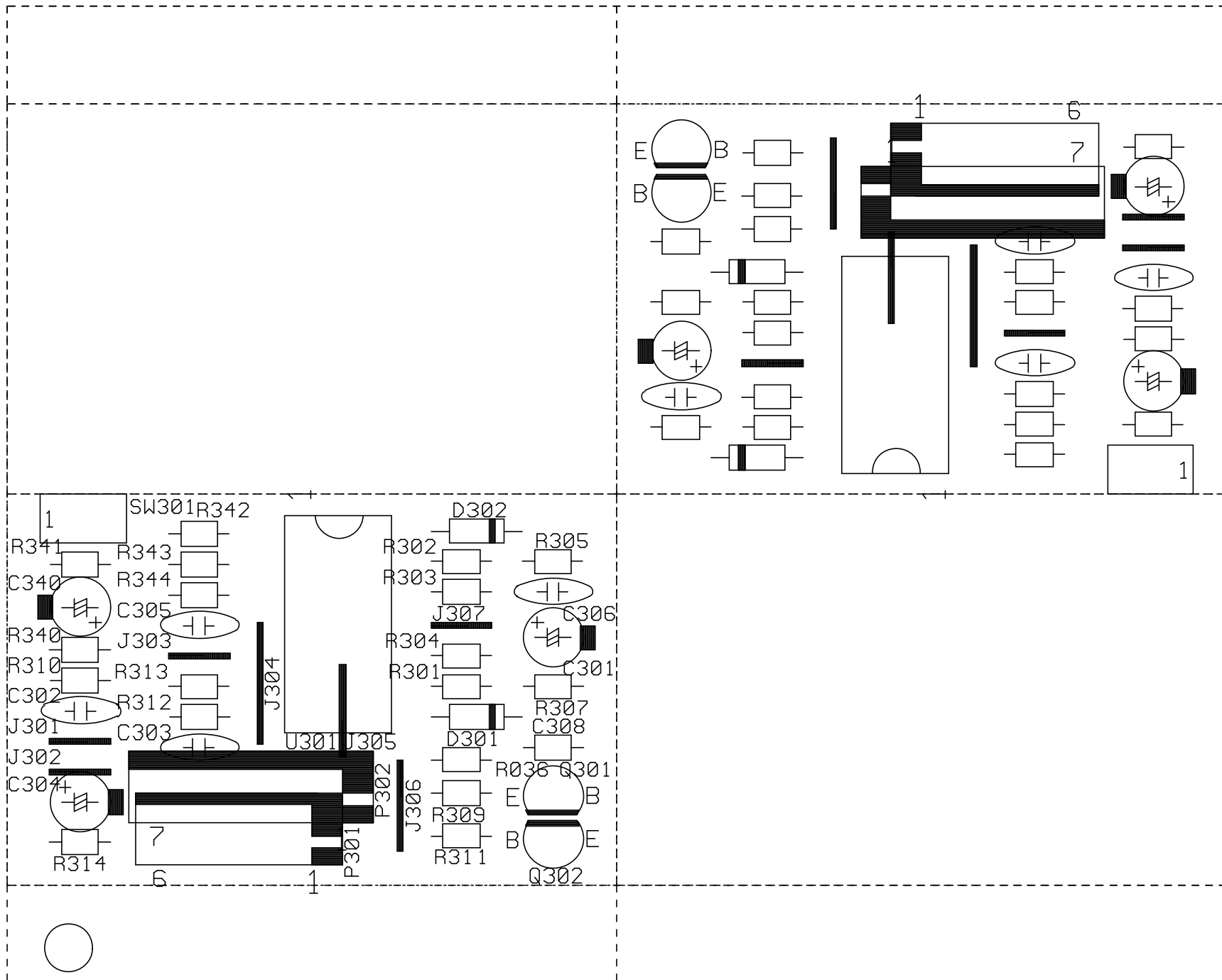

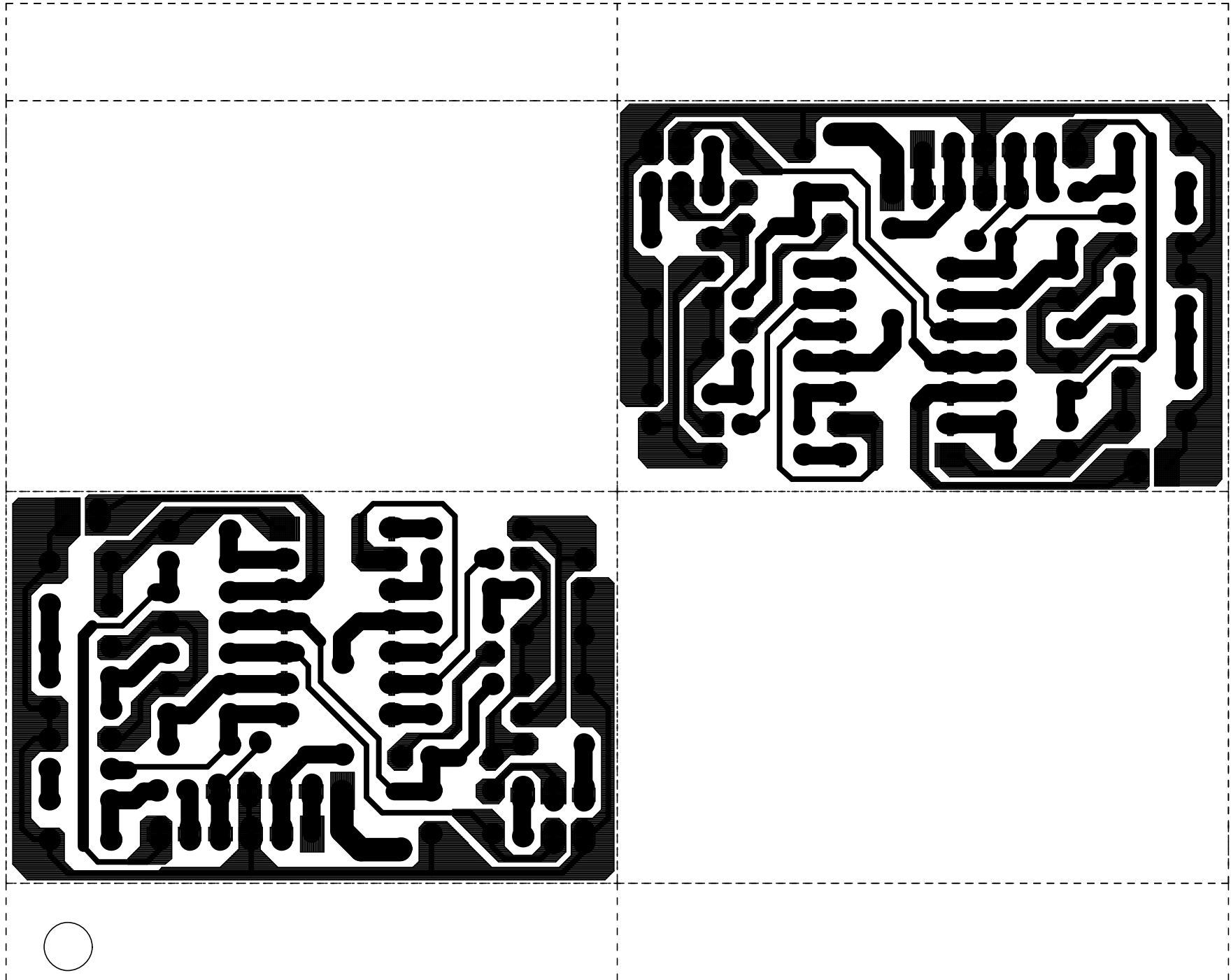

Integrated Circuit Diagrams

4558 Dual Op Amp
U101,203

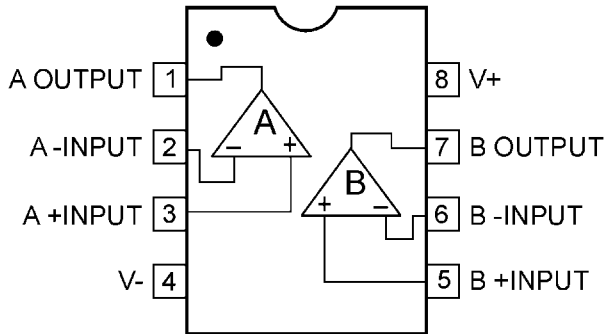

OPAMP, QUAD 14P DIL TL074
U201, 202, 301

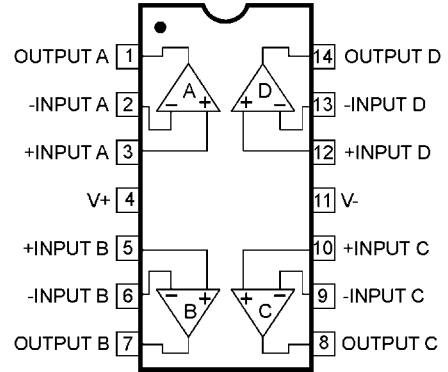

2SA1015
Q114,116

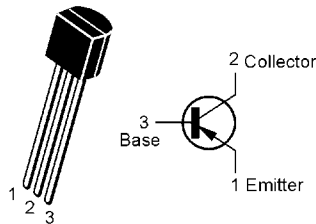

2SC1815
Q101,102,111-116,118,
206,207,301,302

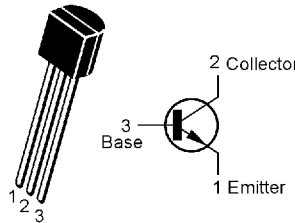

TIP35C, TIP36C
Q107,108

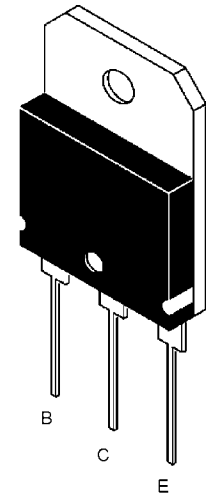

HSD669, HSB649,
KSD882, KSB772

Q105,106,117,119

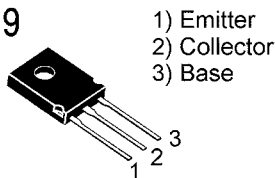

2N5401
Q104, 110

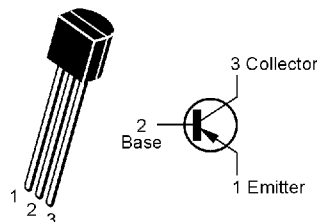

2N5551
Q103, 109

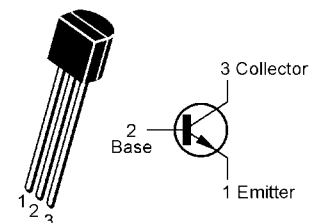

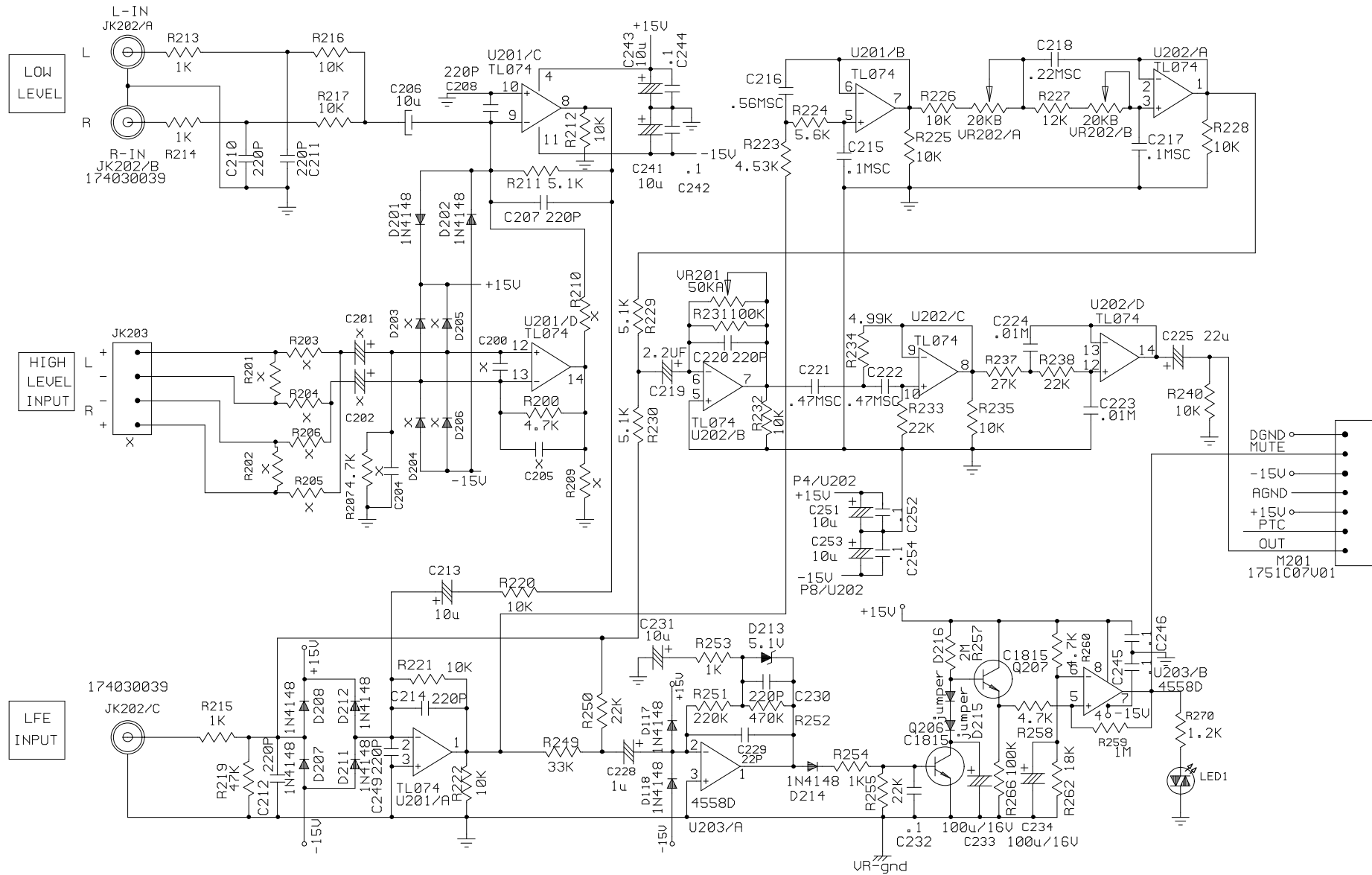

DRAW	FILENAME : PS28U/120U	REVISION : A/1
	MODEL NO. 010-7510-05064-E	PAGE: 1 OF 3
	CUSTOMER: INFINITY	DATE : 2006-7-27
	DWN BY :ZHANGWEI	
DSGN		
APVD		

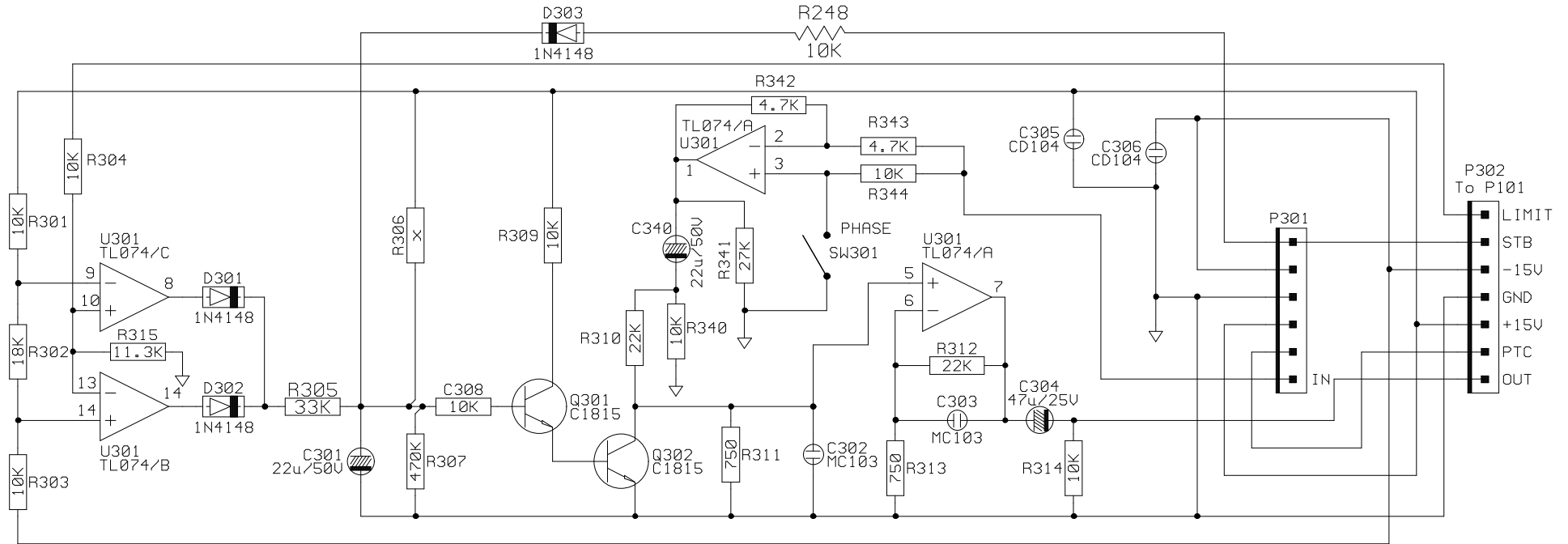

DRAW.	DSGN.	APVD.	FILENAME : PS28U/120V	REVISION : A/1
			MODEL NO. 010-7510-05064-E	PAGE: 2 OF 3
			CUSTOMER: INFINITY	DATE : 2006-7-27
			DWN BY :ZHANGWEI	

PS series PS28 subwoofer

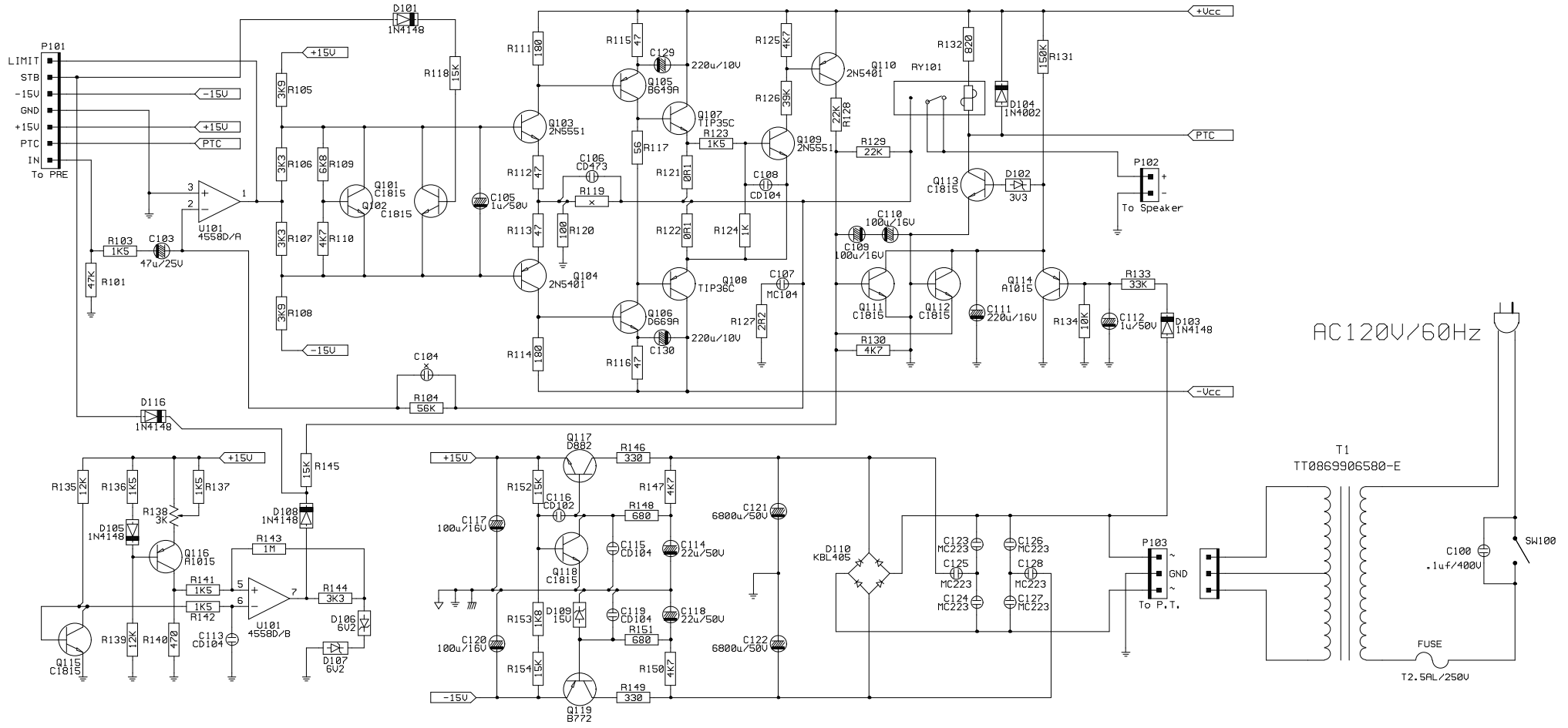

DRAW	DSGN	APVD	FILENAME : PS28U/120U	REVISION : A/1
			MODEL NO. 010-7510-05064-E	PAGE: 3 OF 3
			CUSTOMER: INFINITY	DATE : 2006-7-27
			DWN BY :ZHANGWEI	