

**CD RECEIVER****CR-N1****Instruction Manual**

Thank you for purchasing the ONKYO CR-N1 CD Receiver.

Please read this manual thoroughly before making any connection or turning on the power. Follow these instructions to obtain optimum performance and maximum listening enjoyment from your new CR-N1. Please retain this manual for future reference.

Before using **2**

Controls & connectors **12**

Getting connected **18**

Basic operation **30**

Playing CDs **35**

Listening to the radio **41**

Using the timer **47**

Using USB **51**

Appendix **58**

## WARNING:

TO REDUCE THE RISK OF FIRE OR ELECTRIC SHOCK, DO NOT EXPOSE THIS APPLIANCE TO RAIN OR MOISTURE.

## CAUTION:

TO REDUCE THE RISK OF ELECTRIC SHOCK, DO NOT REMOVE COVER (OR BACK). NO USER-SERVICEABLE PARTS INSIDE. REFER SERVICING TO QUALIFIED SERVICE PERSONNEL.



The lightning flash with arrowhead symbol, within an equilateral triangle, is intended to alert the user to the presence of uninsulated "dangerous voltage" within the product's enclosure that may be of sufficient magnitude to constitute a risk of electric shock to persons.

The exclamation point within an equilateral triangle is intended to alert the user to the presence of important operating and maintenance (servicing) instructions in the literature accompanying the appliance.

# Important Safeguards

- 1. Read Instructions** – All the safety and operating instructions should be read before the appliance is operated.
- 2. Retain Instructions** – The safety and operating instructions should be retained for future reference.
- 3. Heed Warnings** – All warnings on the appliance and in the operating instructions should be adhered to.
- 4. Follow Instructions** – All operating and use instructions should be followed.
- 5. Cleaning** – Unplug the appliance from the wall outlet before cleaning. The appliance should be cleaned only as recommended by the manufacturer.
- 6. Attachments** – Do not use attachments not recommended by the appliance manufacturer as they may cause hazards.
- 7. Water and Moisture** – Do not use the appliance near water—for example, near a bath tub, wash bowl, kitchen sink, or laundry tub; in a wet basement; or near a swimming pool; and the like.
- 8. Accessories** – Do not place the appliance on an unstable cart, stand, tripod, bracket, or table. The appliance may fall, causing serious injury to a child or adult, and serious damage to the appliance. Use only with a cart, stand, tripod, bracket, or table recommended by the manufacturer, or sold with the appliance.  
Any mounting of the appliance should follow the manufacturer's instructions, and should use a mounting accessory recommended by the manufacturer.
- 9. An appliance and cart combination should be moved with care.** Quick stops, excessive force, and uneven surfaces may cause the appliance and cart combination to overturn.
- 10. Ventilation** – Slots and openings in the cabinet are provided for ventilation and to ensure reliable operation of the appliance and to protect it from overheating, and these openings must not be blocked or covered. The openings should never be blocked by placing the appliance on a bed, sofa, rug, or other similar surface. The appliance should not be placed in a built-in installation such as a bookcase or rack unless proper ventilation is provided. There should be free space of at least 20 cm (8 in.) and an opening behind the appliance.
- 11. Power Sources** – The appliance should be operated only from the type of power source indicated on the marking label. If you are not sure of the type of power supply to your home, consult your appliance dealer or local power company.
- 12. Grounding or Polarization** – The appliance may be equipped with a polarized alternating current line plug (a plug having one blade wider than the other). This plug will fit into the power outlet only one way. This is a safety feature. If you are unable to insert the plug fully into the outlet, try reversing the plug. If the plug should still fail to fit, contact your electrician to replace your obsolete outlet. Do not defeat the safety purpose of the polarized plug.
- 13. Power-Cord Protection** – Power-supply cords should be routed so that they are not likely to be walked on or pinched by items placed upon or against them, paying particular attention to cords at plugs, convenience receptacles, and the point where they exit from the appliance.

PORTABLE CART WARNING



S3125A

14. **Outdoor Antenna Grounding** – If an outside antenna or cable system is connected to the appliance, be sure the antenna or cable system is grounded so as to provide some protection against voltage surges and built-up static charges. Article 810 of the National Electrical Code, ANSI/NFPA 70, provides information with regard to proper grounding of the mast and supporting structure, grounding of the lead-in wire to an antenna-discharge unit, size of grounding conductors, location of antenna-discharge unit, connection to grounding electrodes, and requirements for the grounding electrode. See Figure 1.
15. **Lightning** – For added protection for the appliance during a lightning storm, or when it is left unattended and unused for long periods of time, unplug it from the wall outlet and disconnect the antenna or cable system. This will prevent damage to the appliance due to lightning and power-line surges.
16. **Power Lines** – An outside antenna system should not be located in the vicinity of overhead power lines or other electric light or power circuits, or where it can fall into such power lines or circuits. When installing an outside antenna system, extreme care should be taken to keep from touching such power lines or circuits as contact with them might be fatal.
17. **Overloading** – Do not overload wall outlets, extension cords, or integral convenience receptacles as this can result in a risk of fire or electric shock.
18. **Object and Liquid Entry** – Never push objects of any kind into the appliance through openings as they may touch dangerous voltage points or short-out parts that could result in a fire or electric shock. Never spill liquid of any kind on the appliance.
19. **Servicing** – Do not attempt to service the appliance yourself as opening or removing covers may expose you to dangerous voltage or other hazards. Refer all servicing to qualified service personnel.
20. **Damage Requiring Service** – Unplug the appliance from the wall outlet and refer servicing to qualified service personnel under the following conditions:
  - A. When the power-supply cord or plug is damaged,
  - B. If liquid has been spilled, or objects have fallen into the appliance,
  - C. If the appliance has been exposed to rain or water,
  - D. If the appliance does not operate normally by following the operating instructions. Adjust only those controls that are covered by the operating instructions as an improper adjustment of other controls may result in damage and will often require extensive work by a qualified technician to restore the appliance to its normal operation,
  - E. If the appliance has been dropped or damaged in any way, and
  - F. When the appliance exhibits a distinct change in performance – this indicates a need for service.
21. **Replacement Parts** – When replacement parts are required, be sure the service technician has used replacement parts specified by the manufacturer or have the same characteristics as the original part. Unauthorized substitutions may result in fire, electric shock, or other hazards.
22. **Safety Check** – Upon completion of any service or repairs to the appliance, ask the service technician to perform safety checks to determine that the appliance is in proper operation condition.
23. **Wall or Ceiling Mounting** – The appliance should be mounted to a wall or ceiling only as recommended by the manufacturer.
24. **Heat** – The appliance should be situated away from heat sources such as radiators, heat registers, stoves, or other appliances (including amplifiers) that produce heat.

FIGURE 1:  
EXAMPLE OF ANTENNA GROUNDING AS PER NATIONAL ELECTRICAL CODE, ANSI/NFPA 70

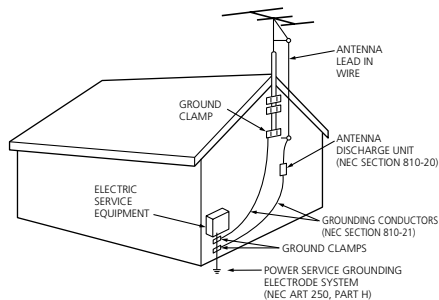

NEC – NATIONAL ELECTRICAL CODE

S2898A

# Precautions

---

## 1. Recording Copyright

Recording of copyrighted material for other than personal use is illegal without permission of the copyright holder.

## 2. AC Fuse

The fuse is located inside the chassis and is not user-serviceable. If power does not come on, contact your Onkyo authorized service station.

## 3. Care

From time to time you should wipe the front and rear panels and the cabinet with a soft cloth. For heavier dirt, dampen a soft cloth in a weak solution of mild detergent and water, wring it out dry, and wipe off the dirt. Following this, dry immediately with a clean cloth. Do not use rough material, thinners, alcohol or other chemical solvents or cloths since these could damage the finish or remove the panel lettering.

## 4. Power

### WARNING

BEFORE PLUGGING IN THE UNIT FOR THE FIRST TIME, READ THE FOLLOWING SECTION CAREFULLY.

The voltage of the available power supply differs according to country or region. Be sure that the power supply voltage of the area where this unit will be used meets the required voltage (e.g., AC 230 V, 50 Hz or AC 120 V, 60 Hz) written on the rear panel.

Setting the STANDBY button to standby does not shut off the power completely. So the power cord should be removed from the AC outlet when the unit is not used for a prolonged time.

## 5. Do not touch this unit with wet hands

Do not handle this unit or power cord when your hands are wet or damp. If water or any other liquid enters the case, take this unit to an authorized service center for inspection.

## 6. Location of this unit

Place this unit in a well-ventilated location.

Take special care to provide plenty of ventilation on all sides of this unit especially when it is placed in an audio rack. If ventilation is blocked, this unit may overheat and malfunction.

Do not expose this unit to direct sunlight or heating units as this unit's internal temperature may rise and shorten the life of the pickup.

Avoid damp and dusty places and places directly affected by vibrations from the speakers. In particular, avoid placing the unit on or above one of the speakers.

Be sure this unit is placed in a horizontal position.

Never place it on its side or on a slanted surface as it may malfunction.

Do not place near tuners or TV sets.

If placed next to a TV or tuner, it may cause reception interference resulting in some noise in the TV or tuner output.

## 7. Points to remember

If this unit is brought from a cold environment to a warm one or is in a cold room that is quickly heated, condensation may form on the pickup, preventing proper operation. In this case, remove the disc and leave the power ON for about one hour to remove the condensation.

When transporting this unit, be careful not to bump it.

---

## **DANGER:**

INVISIBLE LASER RADIATION WHEN OPEN AND INTERLOCK FAILED OR DEFEATED. AVOID DIRECT EXPOSURE TO BEAM.

## **CAUTION:**

THIS PRODUCT UTILIZES A LASER. USE OF CONTROLS OR ADJUSTMENTS OR PERFORMANCE OF PROCEDURES OTHER THAN THOSE SPECIFIED HEREIN MAY RESULT IN HAZARDOUS RADIATION EXPOSURE.

### **For U.S. model**

The laser is covered by a housing which prevents exposure during operation or maintenance. However, this product is classified as a Laser Product by CDRH (Center for Devices and Radiological Health) which is a department of the Food and Drug Administration. According to their regulations 21 CFR section 1002.30, all manufactures who sell Laser Products must maintain records of written communications between the manufacturer, dealers and customers concerning radiation safety. If you have any complaints about instructions or explanations affecting the use of this product, please feel free to write to the address on the back page of this manual. When you write us, please include the model number and serial number of your unit.

In compliance with Federal Regulations, the certification, identification and the period of manufacture are indicated on the rear panel.

### **Note to CATV system installer:**

This reminder is provided to call the CATV system installer's attention to Section 820-40 of the NEC which provides guidelines for proper grounding and, in particular, specifies that the cable ground shall be connected to the grounding system of the building, as close to the point of cable entry as practical.

## **FCC Information for User**

### **CAUTION:**

The user changes or modifications not expressly approved by the party responsible for compliance could void the user's authority to operate the equipment.

### **NOTE:**

This equipment has been tested and found to comply with the limits for a Class B digital device, pursuant to Part 15 of the FCC Rules. These limits are designed to provide reasonable protection against harmful interference in a residential installation. This equipment generates, uses and can radiate radio frequency energy and, if not installed and used in accordance with the instructions, may cause harmful interference to radio communications. However, there is no guarantee that interference will not occur in a particular installation. If this equipment does cause harmful interference to radio or television reception, which can be determined by turning the equipment off and on, the user is encouraged to try to correct the interference by one or more of the following measures:

- Reorient or relocate the receiving antenna.
- Increase the separation between the equipment and receiver.
- Connect the equipment into an outlet on a circuit different from that to which the receiver is connected.
- Consult the dealer or an experienced radio/TV technician for help.

### **For Canadian model**

For models having a power cord with a polarized plug:

**CAUTION:** TO PREVENT ELECTRIC SHOCK, MATCH WIDE BLADE OF PLUG TO WIDE SLOT, FULLY INSERT.

### **NOTE:**

THIS CLASS B DIGITAL APPARATUS COMPLIES WITH CANADIAN ICES-003.

### **Modele pour les Canadien**

Sur les modèles dont la fiche est polarisée:

**ATTENTION:** POUR ÉVITER LES CHOCS ÉLECTRIQUES, INTRODUIRE LA LAME LA PLUS LARGE DE LA FICHE DANS LA BORNE CORRESPONDANTE DE LA PRISE ET POUSSER JUSQU'AU FOND.

### **REMARQUE:**

CET APPAREIL NUMÉRIQUE DE LA CLASSE B EST CONFORME À LA NORME NMB-003 DU CANADA.

## Precautions

### For European model

This unit contains a semiconductor laser system and is classified as a "CLASS 1 LASER PRODUCT". So, to use this model properly, read this Instruction Manual carefully. In case of any trouble, please contact the store where you purchased the unit.

To prevent being exposed to the laser beam, do not try to open the enclosure.



This label on the rear panel states that:

1. This unit is a CLASS 1 LASER PRODUCT and employs a laser inside the cabinet.
2. To prevent the laser from being exposed, do not remove the cover. Refer servicing to qualified personnel.

### For British model

Replacement and mounting of an AC plug on the power supply cord of this unit should be performed only by qualified service personnel.

#### IMPORTANT

The wires in the mains lead are coloured in accordance with the following code:

- Blue : Neutral
- Brown : Live

As the colours of the wires in the mains lead of this apparatus may not correspond with the coloured markings identifying the terminals in your plug, proceed as follows:

The wire which is coloured blue must be connected to the terminal which is marked with the letter N or coloured black.

The wire which is coloured brown must be connected to the terminal which is marked with the letter L or coloured red.

#### IMPORTANT

A 5 ampere fuse is fitted in this plug. Should the fuse need to be replaced, please ensure that the replacement fuse has a rating of 5 amperes and that it is approved by ASTA or BSI to BS1362. Check for the ASTA mark or the BSI mark on the body of the fuse.

IF THE FITTED MOULDED PLUG IS UNSUITABLE FOR THE SOCKET OUTLET IN YOUR HOME THEN THE FUSE SHOULD BE REMOVED AND THE PLUG CUT OFF AND DISPOSED OF SAFELY. THERE IS A DANGER OF SEVERE ELECTRICAL SHOCK IF THE CUT OFF PLUG IS INSERTED INTO ANY 13 AMPERE SOCKET.

If in any doubt, please consult a qualified electrician.

### Trademarks

Apple, Mac, Power Macintosh, and PowerBook are registered trademarks and iBook and iMac are trademarks of Apple Corporation, Inc. Microsoft and Windows are registered trademarks of Microsoft Corporation, Inc.

### Memory backup

The CR-N1 uses a special battery-less memory backup system in order to retain the radio presets and other settings when it's unplugged or in the case of a power failure. Although no batteries are required, the CR-N1 must have been plugged in in order to charge the backup system. Once it has been charged, the CR-N1 will retain its settings for several weeks, although this depends on the environment and will be shorter in humid climates.

#### Declaration of Conformity

We, ONKYO EUROPE  
ELECTRONICS GmbH  
INDUSTRIESTRASSE 20  
82110 GERMERING,  
GERMANY



declare in own responsibility, that the ONKYO product described in this instruction manual is in compliance with the corresponding technical standards such as EN60065, EN55013, EN55020 and EN61000-3-2, -3-3.

GERMERING, GERMANY

  
I. MORI

ONKYO EUROPE ELECTRONICS GmbH

## Features

---

- 2 x 10 watts per channel into 4 ohms (DIN)
- USB input
- USB input/source mixing
- Acoustic Presence
- Energy Save
- RDS (Radio Data System) (European model only)
- Timer play (Weekday, Weekend) and Sleep
- Auto scan FM tuning
- 30 radio presets
- Preset station naming
- FM tuning indicator
- Audio muting (from remote controller)
- Battery-less memory backup
- Optical digital output
- Headphone jack
- Subwoofer pre-output

## Bundled accessories

---

Make sure that the following items are included with your CR-N1.

- Remote controller x1
- Remote controller batteries x2 (AA, R6, UM-3)
- 75/300 ohm antenna adapter x1 (not included with U.S., Canadian, and European models)

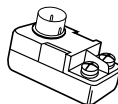
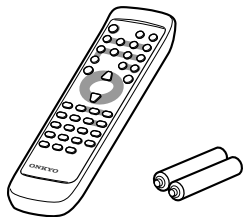

- AM loop antenna x1

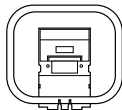

- Indoor FM antenna x1  
(U.S. & Canadian models)

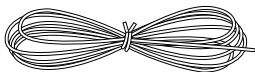

(Other models)



- USB cable (U.S. model only)

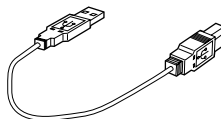

# Remote controller basics

## Installing the batteries

1. Open the battery compartment, as shown.

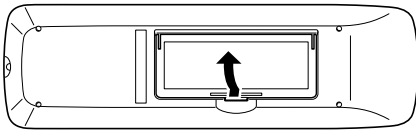

2. Insert the batteries (AA, R6, UM-3) as shown, observing the correct polarity (positive ⊕ and negative ⊖).

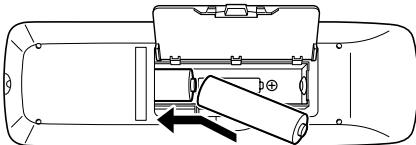

3. Close the battery compartment, as shown.

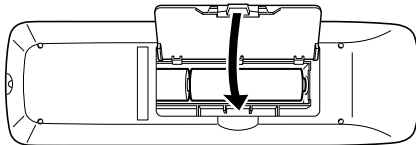

Always replace both batteries at the same time. Never mix new and old batteries or batteries of a different type.

If you do not intend to use the remote controller for an extended period, remove the batteries to prevent possible leakage and corrosion.

Remove dead batteries immediately to prevent possible leakage and corrosion.

If the remote controller doesn't operate reliably, replace both batteries.

The bundled batteries should last about six months, although this varies with usage.

## Using the remote controller

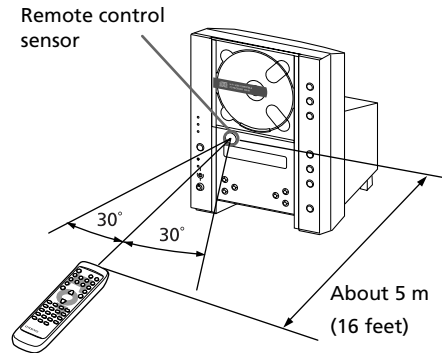

For reliable operation, point the remote controller toward the CR-N1's remote control sensor, as shown.

Situate the CR-N1 away from strong light sources, such as direct sunlight or inverter-type florescent lights, which can affect remote controller performance.

Using another remote controller of the same type in the same room, or using the CR-N1 near equipment that uses infrared light may affect remote controller performance.

Do not put items on top of the remote controller that may inadvertently press the remote controller's buttons, thereby draining the batteries.

The remote controller will not work properly if there's an obstacle between it and the CR-N1's remote control sensor.



# Precautions for handling compact discs

## Playable discs

This unit can play back the following discs.

	Disc logo	Contents	Disc size
Audio CDs		Audio	12 cm
			8 cm (CD single)

You cannot play back discs other than those listed above.

Do not play CD-ROMs intended for computer use or non-audio compact discs. Doing so may cause high-pitched noises or other unpredictable results that may damage speakers, amplifiers, and other connected components.



Avoid using heart-shaped or octagonal discs. Playing irregularly shaped discs may damage the internal mechanism of the unit.

Do not use discs on which adhesive from adhesive tape or a disc label (if it is a rental disc) remains.

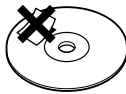

Otherwise, you may not be able to eject the discs or the unit may become inoperative.

## Taking the CD out of the disc case

1. Hold the disc case in the palm of one hand and pull the cover upward with the other hand to open the disc case.



2. While pushing on the center grip of the disc case with your finger, take out the disc by holding its edges.



## Important notes on handling CDs

- Carefully lift the disc from the disc case, making sure to only hold the disc by its edges or the hole in the middle.



- A dry, soft cloth may be used to wipe dust and fingerprints off the surface of CDs.

**OK**



- Do not use volatile agents on discs, such as thinner or benzene. Also, do not use conventional record cleaner or antistatic agents.
- Do not place a CD in direct sunlight or locations subject to high humidity or low temperature.
- Do not store a CD in the CD player tray for long periods of time.

# Contents

---

<b>Before Using</b> .....	<b>2</b>
Important Safeguards .....	2
Precautions .....	4
Features.....	7
Bundled accessories .....	7
Remote controller basics .....	8
Precautions for handling compact discs .....	9
<b>Controls &amp; connectors</b> .....	<b>12</b>
Front panel .....	12
Display .....	14
Rear panel .....	15
Remote controller .....	16
<b>Getting connected</b> .....	<b>18</b>
Connecting speakers.....	18
D-N1 speakers .....	20
Connecting an AM antenna.....	23
Connecting an FM antenna.....	24
Using the 75/300 ohm FM antenna adapter .....	25
Connection notes .....	26
Connecting an analog recorder .....	26
Connecting a digital recorder .....	27
Connecting a subwoofer.....	27
Connecting a computer .....	28
Connecting headphones .....	28
Connecting the power cord .....	29
<b>Basic operation</b> .....	<b>30</b>
Turning the CR-N1 on & off .....	30
Using Energy Save.....	30
Setting the clock .....	31
Calling the clock .....	32
Selecting input sources .....	33
Setting the volume.....	33
Muting the output .....	34
Using Acoustic Presence.....	34

---

<b>Playing CDs</b> .....	<b>35</b>
Loading discs.....	35
Starting playback.....	35
Pausing playback.....	36
Stopping playback.....	36
Selecting tracks.....	36
Searching tracks.....	37
Random playback.....	38
Repeat playback.....	38
Memory playback.....	39
Displaying track times & program numbers.....	40
<b>Listening to the radio</b> .....	<b>41</b>
Tuning the radio.....	41
Presetting FM stations automatically.....	42
Presetting FM/AM stations manually.....	42
Selecting preset stations.....	43
Naming presets.....	44
Editing preset names.....	45
Deleting presets.....	45
Listening to stereo broadcasts.....	46
Using RDS (European models).....	46
<b>Using the timer (remote controller only)</b> .....	<b>47</b>
Programming the timer.....	47
Turning the timers on & off.....	48
Configuring weekdays & weekends.....	49
Using the sleep timer.....	50
<b>Using USB</b> .....	<b>51</b>
Listening to computer audio.....	51
Mixing USB with other sources.....	51
Windows USB setup.....	52
Macintosh USB setup.....	56
<b>Appendix</b> .....	<b>58</b>
Troubleshooting.....	58
Specifications.....	60

# Controls & connectors

## Front panel

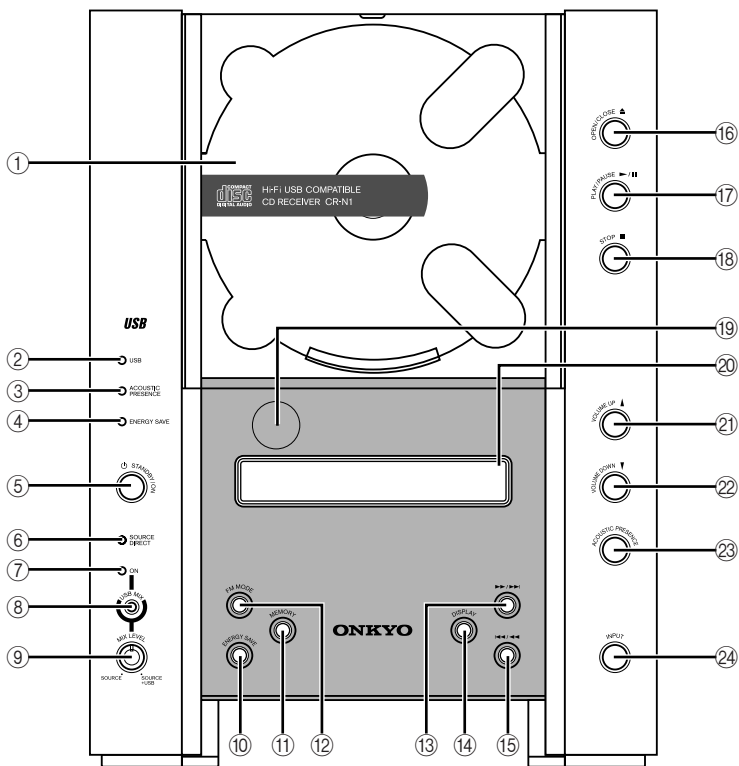

- ① **CD compartment [35]**  
CDs are loaded here.
- ② **USB indicator [53, 56]**  
This indicator lights up when the CR-N1 is successfully recognized by the PC or Mac connected to the USB port.
- ③ **ACOUSTIC PRESENCE indicator [34]**  
This indicator lights up when the Acoustic Presence function is set to either A. PR 1 or A. PR 2.
- ④ **ENERGY SAVE indicator [30]**  
This indicator lights up when the Energy Save function is on.
- ⑤ **STANDBY/ON button [30]**  
This button is used to turn on the CR-N1 and select Standby mode.
- ⑥ **SOURCE DIRECT indicator [51]**  
This indicator lights up when the CD, LINE, USB, FM, and AM sources are selected directly (i.e., when the USB Mix function is off).
- ⑦ **USB MIX ON indicator [51]**  
This indicator lights up when the USB Mix function is on.
- ⑧ **USB MIX button [51]**  
This button is used to turn on and off the USB Mix function.
- ⑨ **USB MIX LEVEL control [51]**  
This control is used to balance the level of the USB signal and the selected source signal when using the USB Mix function.
- ⑩ **ENERGY SAVE button [30]**  
This button is used to turn on and off the Energy Save function.
- ⑪ **MEMORY button [39, 42–45]**  
This button is used with CD Memory Playback and when presetting radio stations.
- ⑫ **FM MODE button [45]**  
This button is used to set the FM mode to either Auto or Mono.
- ⑬ **Next/Preview/Tuning button [36–39, 41, 43–45]**  
When playing CDs, this button is used to select the next track, subsequent tracks, or to preview. It's also used for tuning the radio.
- ⑭ **DISPLAY button [40, 44–46]**  
When playing CDs, this button is used to display the remaining track, disc, and program times. It's also used when naming radio presets.
- ⑮ **Previous/Review/Tuning button [36–39, 41, 43–45]**  
When playing CDs, this button is used to select the beginning of the current track, previous tracks, or to review. It's also used for tuning the radio.
- ⑯ **OPEN/CLOSE button [35]**  
This button is used to open and close the disc compartment.
- ⑰ **PLAY/PAUSE button [35, 36]**  
This button is used to start and pause CD playback.
- ⑱ **STOP button [36]**  
This button is used to stop CD playback.
- ⑲ **Remote control sensor [8]**  
This sensor receives command signals from the remote controller.
- ⑳ **Display [14]**  
The display shows function settings and other information. The current time is displayed when the CR-N1 is in Standby mode.
- ㉑ **VOLUME UP button [33]**  
This button is used to increase the volume.
- ㉒ **VOLUME DOWN button [33]**  
This button is used to decrease the volume.
- ㉓ **ACOUSTIC PRESENCE button [34]**  
This button is used to turn on and off the Acoustic Presence function.
- ㉔ **INPUT selector button [33]**  
This button is used to select the CD, LINE, USB, FM, and AM input sources.

## Display

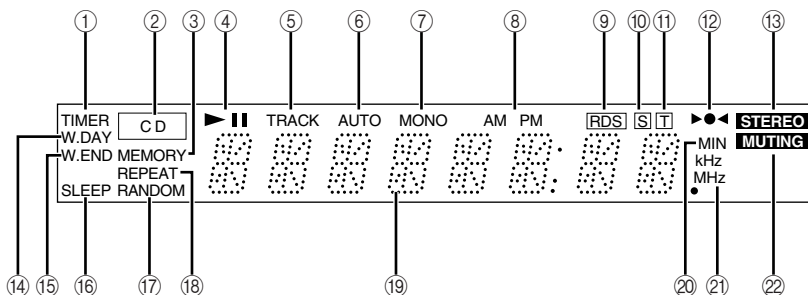

- |  |  |
|--|--|
| ① <b>TIMER</b> indicator                       | ⑪ <b>Total disc remaining time</b> indicator |
| ② <b>CD</b> indicator                          | ⑫ <b>Tuning</b> indicator                    |
| ③ <b>MEMORY</b> indicator                      | ⑬ <b>STEREO</b> indicator                    |
| ④ <b>Play/Pause</b> indicators                 | ⑭ <b>W.DAY</b> indicator                     |
| ⑤ <b>TRACK</b> indicator                       | ⑮ <b>W.END</b> indicator                     |
| ⑥ <b>AUTO</b> indicator                        | ⑯ <b>SLEEP</b> indicator                     |
| ⑦ <b>MONO</b> indicator                        | ⑰ <b>RANDOM</b> indicator                    |
| ⑧ <b>AM/PM</b> indicators                      | ⑱ <b>REPEAT</b> indicator                    |
| ⑨ <b>RDS</b> indicator (European model)        | ⑲ <b>Main display</b>                        |
| ⑩ <b>Single track remaining time</b> indicator | ⑳ <b>Sleep time</b> indicator                |
|  | ㉑ <b>Frequency</b> indicators                |
|  | ㉒ <b>MUTING</b> indicator                    |

## Rear panel

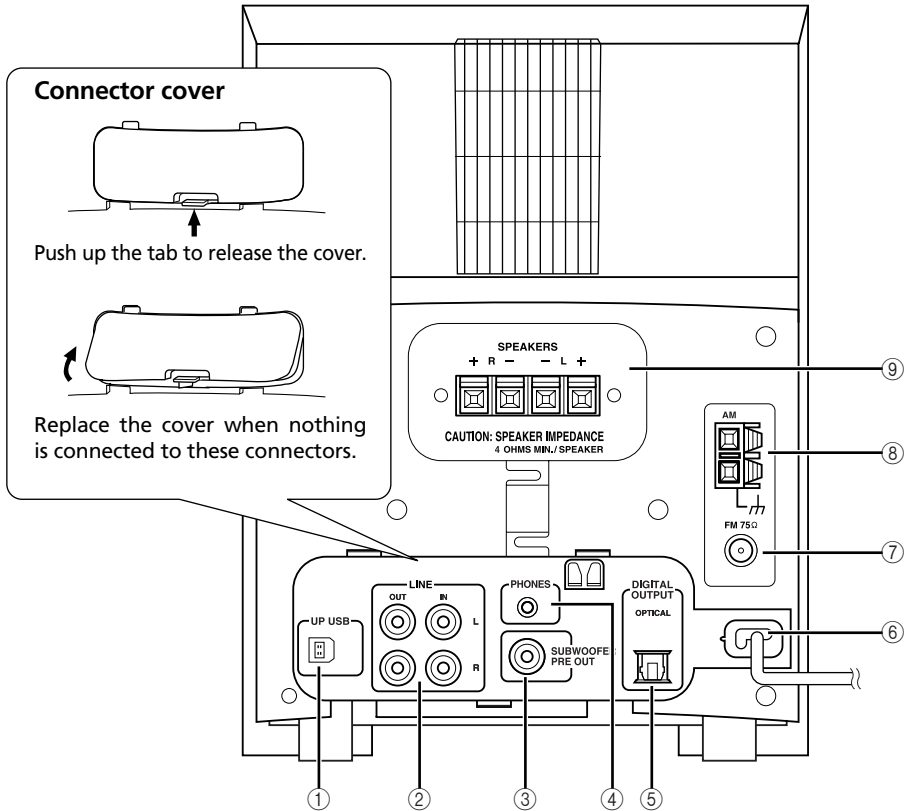

- ① UP USB port [28]
- ② LINE IN/OUT connectors [26]
- ③ SUBWOOFER PRE OUT connector [27]
- ④ PHONES jack [28]
- ⑤ OPTICAL DIGITAL OUTPUT connector [27]
- ⑥ Power cord [29]
- ⑦ FM 75Ω antenna connector [24]
- ⑧ AM antenna terminals [23]
- ⑨ SPEAKERS terminals [18]

**Remote controller**

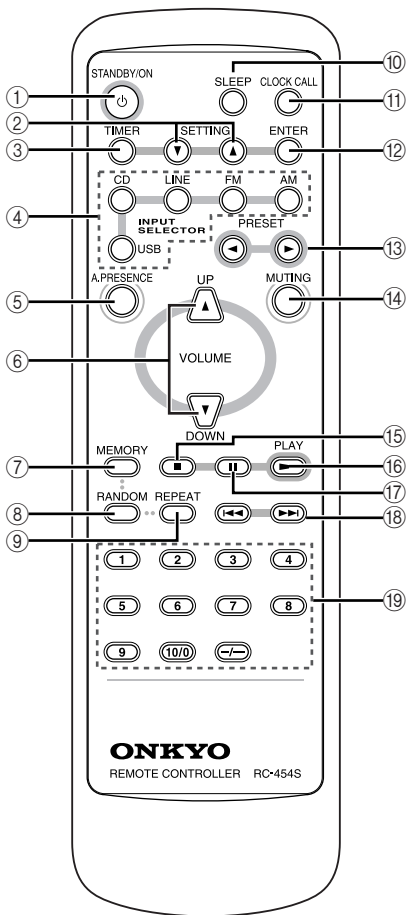

- ① **STANDBY/ON button [30]**  
This button is used to turn on the CR-N1 and select Standby mode.
- ② **SETTING buttons [31, 47–49]**  
These buttons are used in conjunction with the timer functions
- ③ **TIMER button [31, 47–49]**  
This button is used to select the various Timer functions.
- ④ **CD, LINE, FM, AM, USB INPUT SELECTOR buttons [33]**  
These buttons are used to select the CD, LINE, FM, AM, and USB input sources.
- ⑤ **A.PRESENCE button [34]**  
This button is used to turn on and off the Acoustic Presence function.
- ⑥ **VOLUME UP/DOWN buttons [33]**  
These buttons are used to increase and decrease the volume.
- ⑦ **MEMORY button [39, 42–45]**  
This button is used with CD Memory Playback and when presetting radio stations.
- ⑧ **RANDOM button [38]**  
This button is used to turn on and off the CD Random playback function.
- ⑨ **REPEAT button [38]**  
This button is used to turn on and off the CD Repeat playback function.
- ⑩ **SLEEP button [50]**  
This button is used to set the Sleep function.
- ⑪ **CLOCK CALL button [32]**  
This button activates the Clock call function, which displays the current day and time on the display.
- ⑫ **ENTER button [31, 47–49]**  
This button is used in conjunction with the Timer functions.
- ⑬ **PRESET buttons [43]**  
These buttons are used to select preset radio stations.



- ⑭ **MUTING button [34]**  
This button is used to temporarily mute the sound output.
- ⑮ **Stop button [36]**  
This button is used to stop CD playback.
- ⑯ **PLAY button [35]**  
This button is used to start CD playback.
- ⑰ **Pause button [36]**  
This button is used to pause CD playback.
- ⑱ **Previous/Next buttons [36, 39]**  
The Previous button is used to select the beginning of the current track or previous tracks. The Next button is used to select the next track or subsequent tracks.
- ⑲ **Numeric keypad [31, 37, 39]**  
These buttons are used when setting the clock, selecting CD tracks, or memorizing CD tracks for Memory playback.

# Getting connected

## Connecting speakers

- Connect speakers only as shown here. Incorrect connections may damage the CR-N1 and the speakers.
- The minimum impedance for each speaker is 4 ohms.
- Unnecessarily long, or very thin speaker cables may affect the sound quality and should be avoided.
- Do not connect more than one speaker to each pair of terminals.
- Turn off the CR-N1 before connecting any speakers. Failure to do so may damage the CR-N1 or the speakers.
- See page 20 for information on connecting the Onkyo D-N1 speakers.

## Preparing the speaker cables

1. Strip 15 mm (5/8") of insulation from the ends of the speaker cables, as shown.

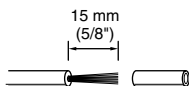

2. Twist the bare wires, as shown.

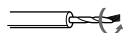

- Do not connect the AC power cord to a wall outlet until you've completed all other connections, including antenna (see page 23).

## Connecting the speakers

Speakers must be connected only as shown here.

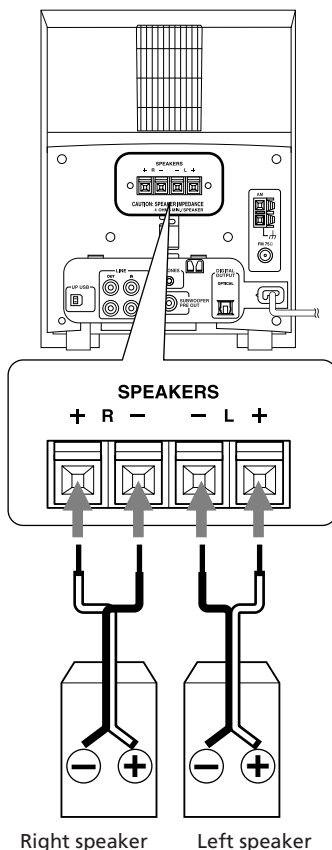

Make sure that each (+) speaker terminal is connected to the correct (+) CR-N1 SPEAKERS terminal, and that each (-) speaker terminal is connected to the correct (-) CR-N1 SPEAKERS terminal. Incorrect speaker wiring will affect the sound quality and may damage the CR-N1 or the speakers.

## Incorrect speaker wiring

Never connect speakers as shown below, as this will damage the CR-N1 or the speakers.

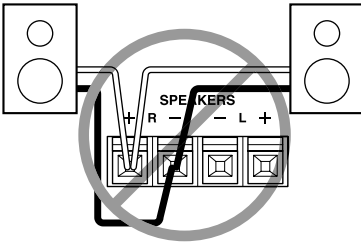
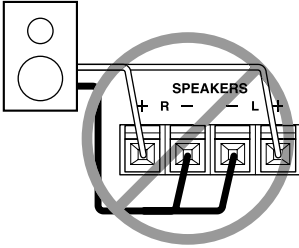

Make sure that the terminals are gripping the bare wires, not the insulation.

A short between the positive and negative speaker terminals may damage the CR-N1, so make sure that the speaker cables are attached securely to the speaker terminals and that there is no chance of any bare wires touching each other.

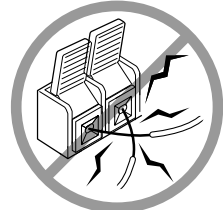

## Attaching the wires

1. Push up the lever to open the terminal.

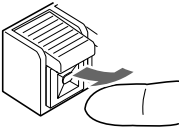

2. Insert the bare wires into the terminal.

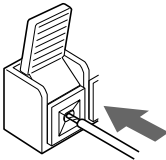

3. Push down the lever to close the terminal.

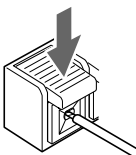

## D-N1 speakers

Note that the D-N1 speakers are not supplied with all models.

### Location precautions

- The speaker cabinets are made from wood, making them sensitive to extreme temperatures and humidity.
- Do not put the speakers in locations subject to direct sunlight or in humid places, such as near an air conditioner, bathroom, or kitchen.

Front views

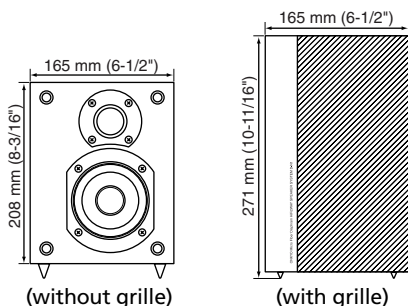

Side view

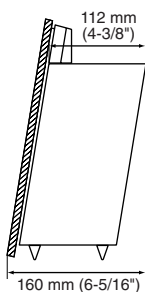

### Using with a TV or computer

TVs and computer monitors are magnetically sensitive devices and as such are likely to suffer from discoloration or picture distortion when normal speakers are placed nearby. To prevent this, the D-N1 speakers feature internal magnetic shielding. In some situations, however, discoloration may still be an issue, in which case you should turn off the TV or monitor, wait 15 to 30 minutes, and then turn back on again. This normally activates the degaussing function, which neutralizes the magnetic field, thereby removing any discoloration effects. If discoloration problems remain, try moving the speakers away from the TV or monitor. Note that discoloration may also be caused by a magnet or demagnetizing tool in close proximity to the TV or monitor.

When speakers are used close to a TV or computer monitor, due to the noise caused by the electromagnetic waves from the TV or monitor, you may hear noise from the speakers even after the CR-N1 has been turned off. To prevent this, position the speakers away from the TV or computer monitor.

### Operation precautions

The speakers have been designed to handle the specified input power when used for normal music reproduction. If any of the following abnormal signals are fed to the speakers, even if the input power is within the specified range, the speakers may be damaged: noise produced when no FM station is tuned; the sound produced when fast forwarding a cassette tape deck; high-frequency sounds generated by an oscillator, electronic musical instrument, and so on; oscillating amplifier signals; special test signals from audio test CDs, and so on; sounds produced when connecting and disconnecting audio cables (always turn off the CR-N1 before connecting and disconnecting audio cables); microphone feedback.

Since the tweeters use strong magnets, do not place metal objects such as screwdrivers near to them. Otherwise, the object may be attracted towards the tweeter causing injury or damage to the tweeter.

## Connecting

- Connect the speakers only as shown here. Incorrect connections may damage the CR-N1 or the speakers.

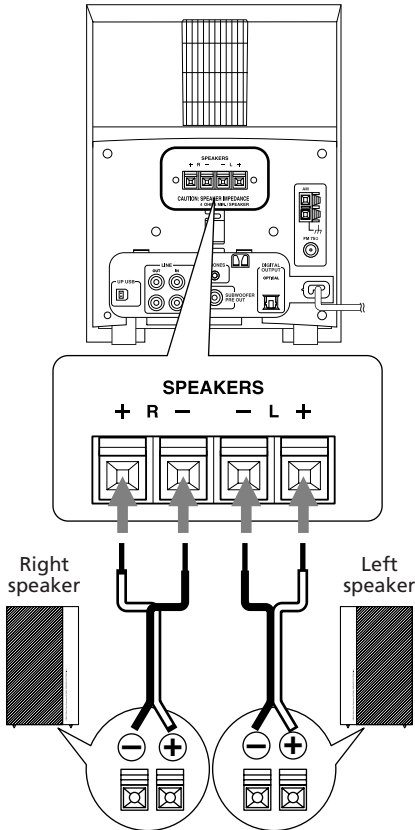

These terminals are located on the underside of the D-N1 speakers.

- Use the supplied speaker cables. Unnecessarily long, or very thin speaker cables may affect the sound quality and should be avoided.
- Turn off the CR-N1 before connecting any speakers. Failure to do so may damage the CR-N1 or the speakers.
- Make sure that each (+) speaker terminal is connected to the correct (+) CR-N1 SPEAKERS terminal, and that each (-) speaker terminal is connected to the correct (-) CR-N1 SPEAKERS terminal. Incorrect speaker wiring will affect the sound quality and may damage the CR-N1 or the speakers.

## Removing the speaker grilles

The D-N1 speakers can be used either with or without the grilles, which can be removed and replaced as follows.

1. Hold the grille at the top using both hands and pull it gently away from the speaker to release the top two fasteners.
2. Hold the grille at the bottom using both hands and pull it gently away from the speaker to release the bottom two fasteners.
3. To replace the grille, line up the top and bottom fasteners and gently push the grille onto the speaker.

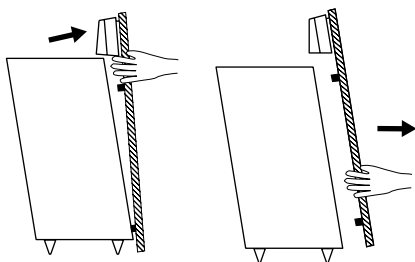

### Note:

Do not attempt to carry the speaker by holding only its grille. Carry the whole speaker. There is a risk that the speaker will be dropped if the grille separates from the cabinet.

## Speaker care

Onkyo uses a very high quality polymer laminate covering to protect its wooden speaker cabinets. To maintain their appearance, you should periodically wipe them with a soft dry cloth. Stubborn stains can be removed by using a soft cloth dampened with water and a mild detergent. Do not use furniture polish or strong cleaning solutions. Dust and lint can be removed from the speaker grilles by using a soft brush, or a vacuum cleaner with a brush attachment.

## D-N1 Specifications

Type	2-way bass reflex
Impedance	4Ω
Maximum input power	30 watts
Output sound pressure level	83 dB/W/m
Frequency response	63 Hz–35 kHz
Crossover frequency	3 kHz
Cabinet capacity	2.6 liter
Speakers	Woofer: 9 cm cone x1 Tweeter: 2.5 cm dome x1
Dimensions (W x H x D)	165 x 271 x 160 mm (6-1/2" x 10-11/16" x 6-5/16")
Weight	1.7 kg (3.7 lbs)
Others	Magnetic shielding Symmetrical type
Supplied accessories	1 meter speaker cable x2

Specifications and features are subject to change without notice.

## Connecting an AM antenna

The bundled AM loop antenna is designed for indoor use only.

### Using the bundled AM loop antenna

1. Assemble the AM antenna, as shown.

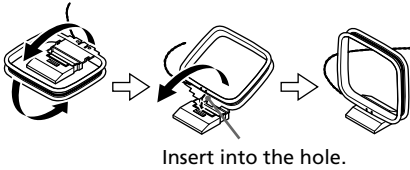

The AM antenna needs to be connected to the AM terminals located on the rear of the CR-N1, as shown.

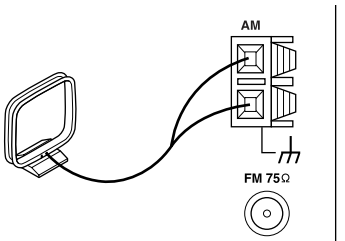

2. To connect an antenna wire, push the terminal lever, insert the bare wires, and then release the lever, as shown.

1. Push

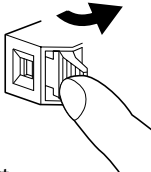

2. Insert

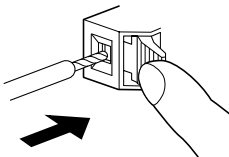

3. Release

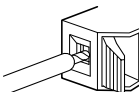

Make sure that the wires are attached securely and that the terminals are gripping the bare wires, not the insulation. Once the CR-N1 is ready for use, you'll need to tune into an AM radio station and adjust the position of the AM antenna in order to achieve the best possible reception. Keep it as far away as possible from the CR-N1, speaker cables, power cord, and your computer.

### Using an outdoor AM antenna

If good reception cannot be achieved using the bundled AM loop antenna, an outdoor AM antenna can be used as well, as shown.

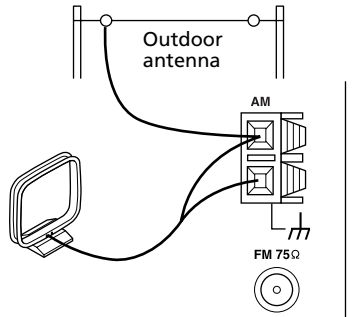

Outdoor AM antennas work best outside, but good results can sometimes be obtained indoors by mounting horizontally above a window. Note that the AM loop antenna should be left connected.

Outdoor antenna must be grounded in accordance with local regulations to prevent electrical shock hazards. See item 14 of "Important safeguards" at the front of this manual.

## Connecting an FM antenna

The bundled indoor FM antenna is designed for indoor use only.

### Using the bundled FM antenna

#### 1. Attach the FM antenna, as shown.

##### U.S. and Canadian models

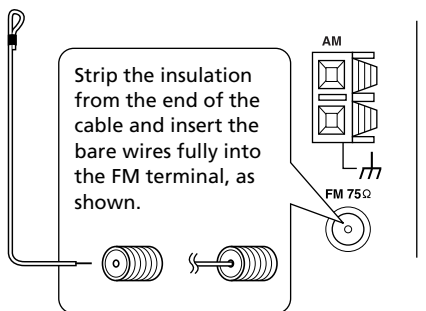

##### Other models

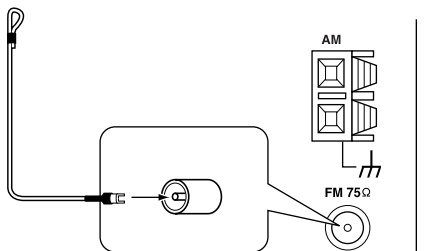

Once the CR-N1 is ready for use, you'll need to tune into an FM radio station and adjust the position of the FM antenna in order to achieve the best possible reception.

#### 2. Use thumbtacks (drawing pins) or something similar to fix the antenna into position.

### Using an outdoor FM antenna

If good reception cannot be achieved using the bundled indoor FM antenna, an outdoor FM antenna can be used instead, as shown.

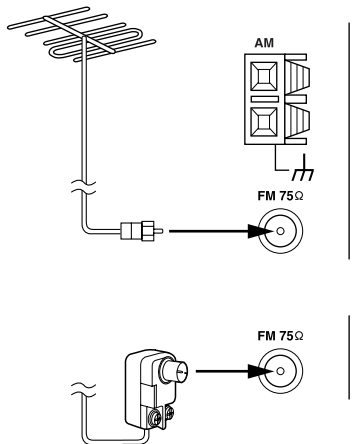

Outdoor FM antennas work best outside, but good results can sometimes be obtained indoors by mounting in an attic or loft.

Outdoor antenna should be located away from possible noise sources, such as neon signs, busy roads, etc.

For safety reasons, outdoor antenna should be situated well away from power lines.

Outdoor antenna must be grounded in accordance with local regulations to prevent electrical shock hazards. See item 14 of "Important safeguards" at the front of this manual.

### Using a TV antenna

It's best not to use the same antenna for both FM and TV reception, as this can cause interference problems. If circumstances demand using the same antenna, use a TV/FM antenna splitter, as shown.

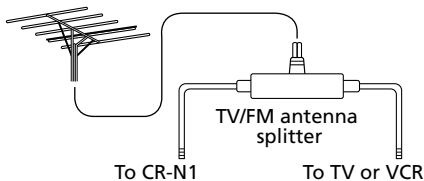



## Using the 75/300 ohm FM antenna adapter

(The 75/300 ohm antenna adapter is not included with the U.S., Canadian, and European models.)

The 75/300 ohm antenna adapter can be used to connect an FM antenna with 300 ohm flat twin-core cable, or to connect an FM antenna with a 75 ohm coaxial cable with no connector attached.

### Connecting 300 ohm flat twin-core cable

1. Undo the two adapter screws, wrap the bare wires around the screws, and then retighten the screws, as shown.

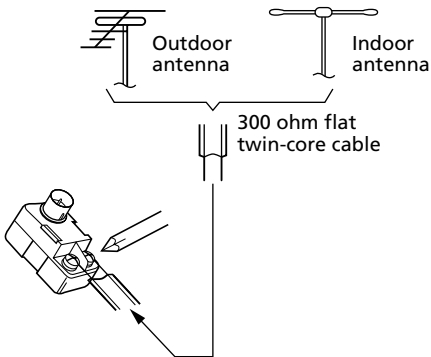

2. Plug the 75/300 ohm adapter into the CR-N1's FM 75Ω connector.

### Connecting 75 ohm coaxial cable

1. Using a small screwdriver or your fingernails, push the tabs outwards and remove the adapter's cover, as shown.

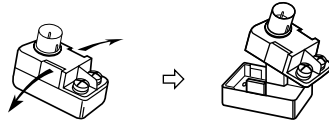

2. Move the wire inside the adapter from position A to position B, as shown.

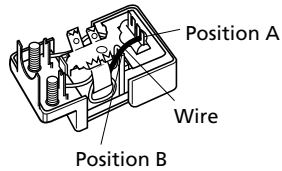

3. Prepare the end of the 75 ohm coaxial cable and place it in the adapter, as shown.

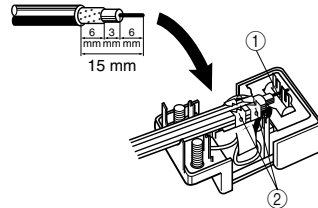

4. Push the center conductor between the lugs as shown (①), and use a pair of pliers to clamp the braided wire section of the cable to the adapter (②). Make sure that the braided wires are not shorting to the center conductor.

### Connection notes

- Do not connect the AC power cord to a wall outlet until you've completed all other connections, including speakers (see page 18) and antenna (see page 23).
- For audio connections, the red connector (marked "R") corresponds to the right channel, and the white connector (marked "L"), to the left channel. Always connect white plugs to connectors labeled "L," and red plugs to the connectors labeled "R."

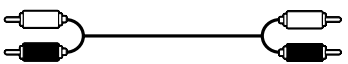
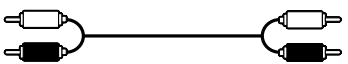
To "L" connector ← (White)  (White) → To "L" connector  
To "R" connector ← (Red)  (Red) → To "R" connector

Audio connection cable

- Refer to the relevant instruction manuals when connecting other equipment to the CR-N1.
- Loose connections can cause noise or abnormal operation, so make sure that plugs are inserted correctly.
- Do not bend, tie, or coil optical digital audio cables.
- For optimum sound quality, keep audio cables away from power cords and speaker cables.

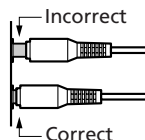

### Connecting an analog recorder

An analog recorder such as a cassette deck can be connected to the CR-N1's LINE IN/OUT phono jacks for tape playback and recording, as shown. Only the selected source signal is output from the LINE OUT, not the USB Mix.

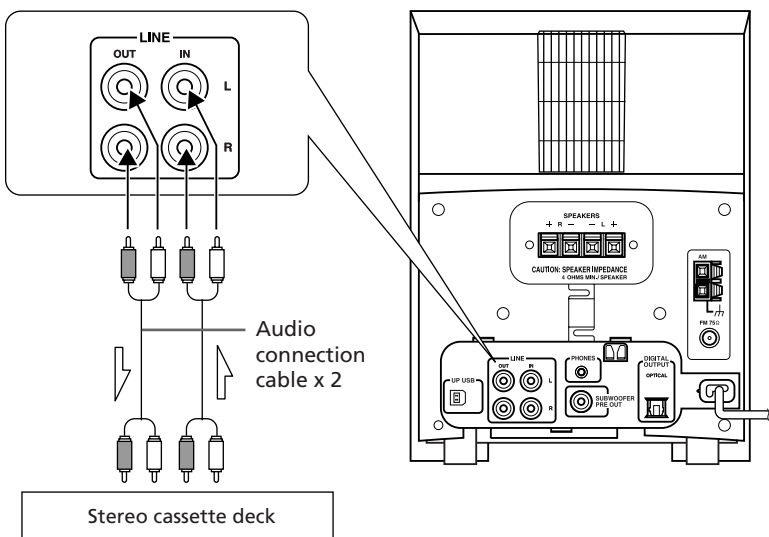

## Connecting a digital recorder

A digital recorder such as an MD, DAT, or CDR can be connected to the CR-N1's OPTICAL DIGITAL OUTPUT for digital recording. Only CD playback signals are output via the OPTICAL DIGITAL OUTPUT.

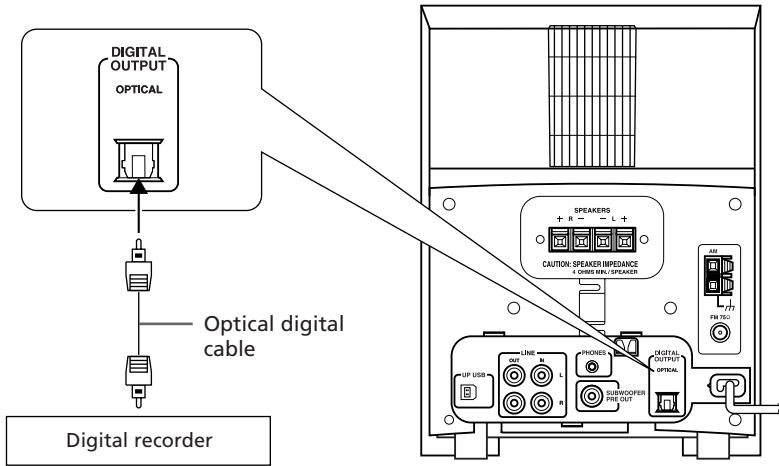

## Connecting a subwoofer

A powered subwoofer can be connected to the CR-N1's SUBWOOFER PRE OUT phono jack for enhanced bass performance.

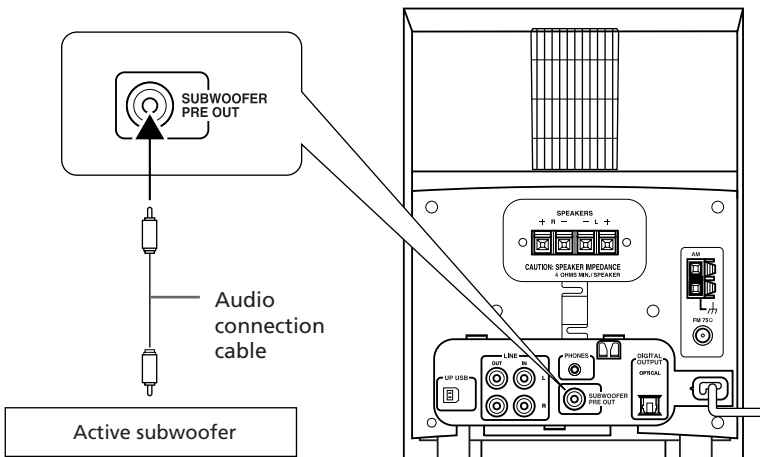

## Connecting a computer

By connecting a computer to the CR-N1's UP USB port, audio from the computer can be listened to with high quality.

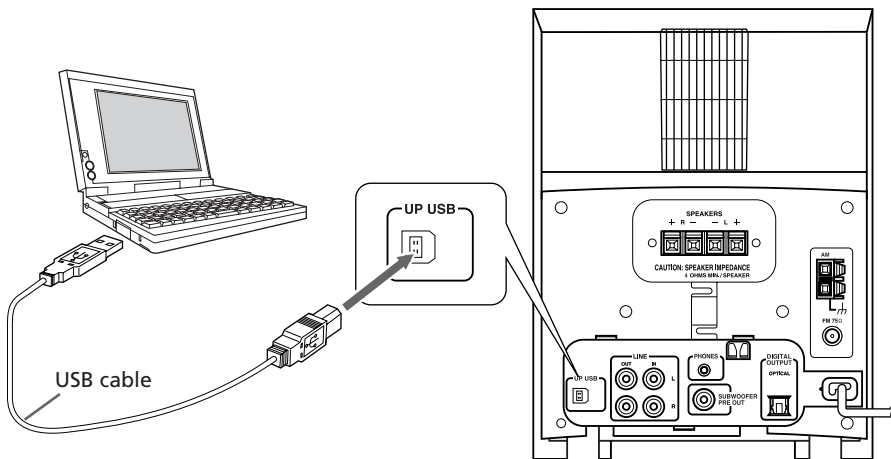

Before connecting your computer, see “Windows USB setup” on page 52 or “Macintosh USB setup” on page 56.

## Connecting headphones

Stereo headphones can be connected to the CR-N1's rear-panel headphone mini-jack for private listening.

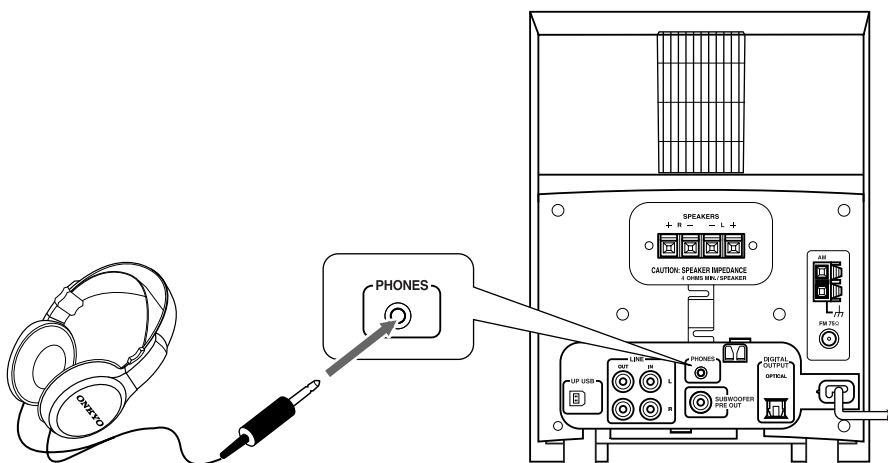

The speakers are disconnected while the headphone plug is inserted into the PHONES jack.

## Connecting the power cord

Once you've completed all the other connections, it's time to connect the power cord.

### 1. Connect the AC power cord to a suitable wall outlet.

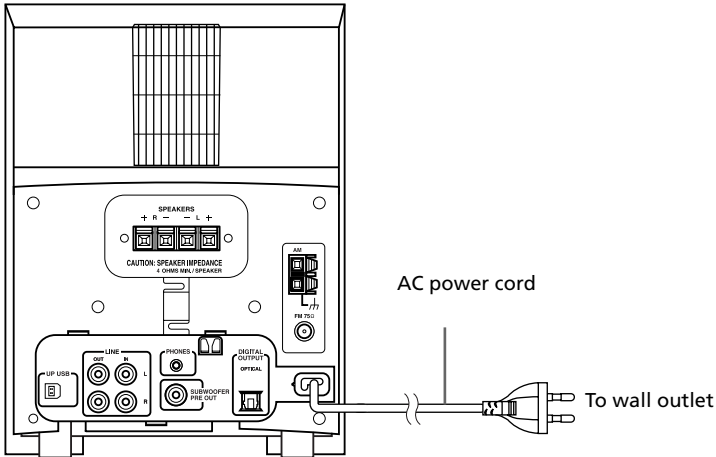

(Illustration shows European model)

The CR-N1 switches to Standby mode and “--:--” appears on the display. Once the clock has been set (see page 31), the day and time are displayed in Standby mode.

If you do not intend to use the CR-N1 for an extended period, remove the power cord from the AC outlet.

# Basic operation

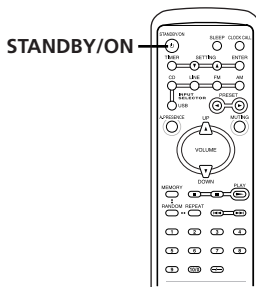
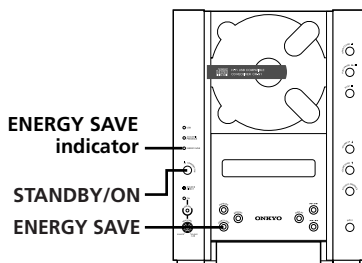

## Turning the CR-N1 on & off

- 1 Press the **STANDBY/ON** (⏻) button on the CR-N1 or remote controller.

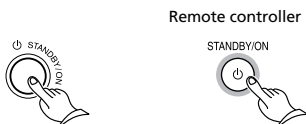

The display lights up and the CR-N1 is ready for use.

Press the **STANDBY/ON** (⏻) button again to enter Standby mode.

Note: If you turn the CR-N1 on or off, or connect or disconnect the USB cable while your computer is outputting sound (e.g., playing back audio), or while launching audio playback software, your computer may become unstable. Always quit audio playback software before turning the CR-N1 on or off, or before connecting or disconnecting the USB cable.

If the CR-N1 is turned on or off frequently, or the USB cable connected or disconnected frequently while your computer is up and running, in some cases your computer may stop operating normally. In this case, you should restart your computer.

## Using Energy Save

The Energy Save function reduces power consumption while the CR-N1 is in Standby mode.

- 1 In Standby mode, press the **ENERGY SAVE** button on the CR-N1 (the **ENERGY SAVE** indicator lights up and the clock display disappears).

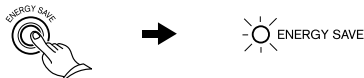

- 2 To turn off Energy Save mode, press the **ENERGY SAVE** button again.

The Energy Save function can be turned on or off while the CR-N1 is either on or in Standby mode. When the **ENERGY SAVE** button is pressed while the CR-N1 is on, although the **ENERGY SAVE** indicator lights up, Energy Save mode is not engaged until the Standby mode is selected by pressing the **STANDBY/ON** (⏻) button.

Although the clock display is turned off in Energy Save mode, the timer functions still work.

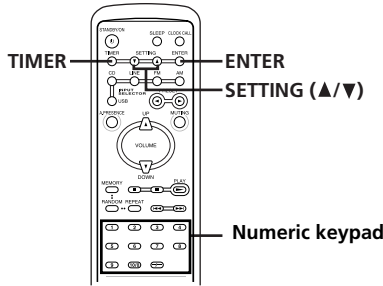

## Setting the clock

The remote controller is used to set the clock.

### Setting the day & time

- 1 Press the **TIMER** button repeatedly until "ADJUST" appears on the display, and then press the **ENTER** button.

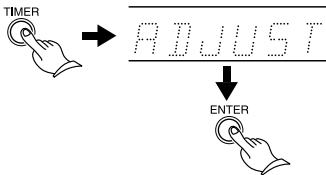

The day of the week flashes on the display.

- 2 Use the **SETTING (▼/▲)** buttons, or the numeric keypad to select the day of the week, and then press the **ENTER** button (the time flashes on the display).

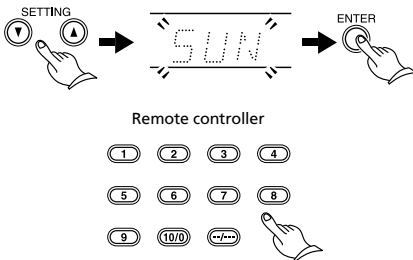

Days are selected using the numeric keypad as follows:

- |        |        |        |        |
|--------|--------|--------|--------|
| 1: SUN | 2: MON | 3: TUE | 4: WED |
| 5: THU | 6: FRI | 7: SAT |        |

Note that the clock must be set to the 24 hour format in order to use the numeric keypad to set the day and time.

- 3 Use the **SETTING (▼/▲)** buttons, or the numeric keypad to set the time, and then press the **ENTER** button (the clock is now set.).

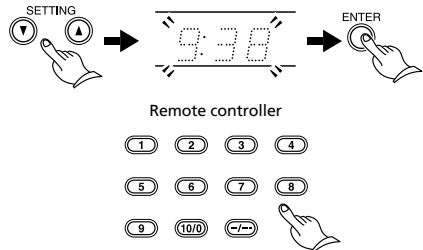

The time is entered using the numeric keypad as follows:

To enter 09:38 a.m., press the following buttons: 10/0, 9, 3, 8, and then **ENTER**.

To enter the time 11:00 a.m., press the following buttons: 1, 1, 10/0, 10/0, and then **ENTER**.

If you set the clock while the CR-N1 is in Standby mode, the time is displayed. If you set it while the CR-N1 is on, the previously displayed information reappears.

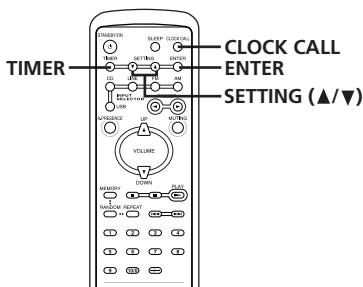

### Selecting 12 or 24 hour display

The CR-N1 can display time in the 12- or 24-hour format.

- 1 Press the **TIMER** button repeatedly until "24H/12H" appears on the display, and then press the **ENTER** button.

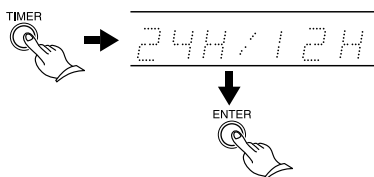

The current setting ("24H" or "12H") flashes on the display.

- 2 Use the **SETTING (▼/▲)** buttons to select either 24H (24 hour clock) or 12H (12 hour clock), and then press the **ENTER** button.

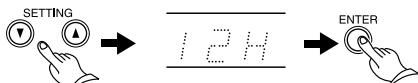

The clock format is set.

### Calling the clock

The time can be displayed at anytime by using the Clock Call function.

- 1 Press the **CLOCK CALL** button.

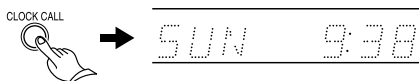

The day and time are displayed.

After a few seconds, the day display is replaced by the selected input source (e.g., CD, LI (LINE), FM, AM, or USB).

- 2 To cancel the Clock Call function, press the **CLOCK CALL** button again.

If the clock has not been set when the CLOCK CALL button is pressed, "ADJUST" appears on the display. In this case, press the CLOCK CALL button again to cancel, and then set the clock as explained on page 31.



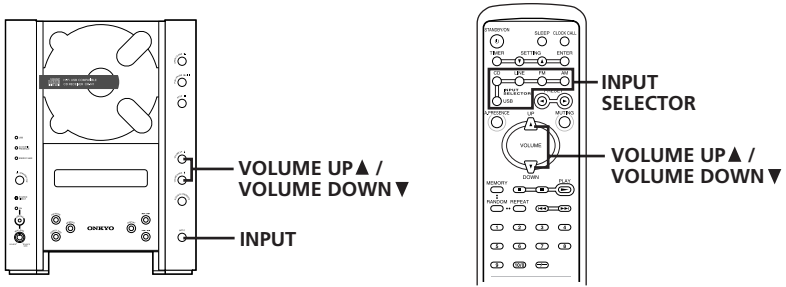

### Selecting input sources

The following input sources can be selected:

Input source	Description
CD	CR-N1's CD player
LINE	Rear panel LINE inputs
USB	Rear panel USB port
FM	CR-N1's FM radio
AM	CR-N1's AM radio

**1** Press the **INPUT** button on the **CR-N1** repeatedly, or use the **CD**, **LINE**, **FM**, **AM**, or **USB INPUT SELECTOR** buttons on the remote controller to select the required input source.

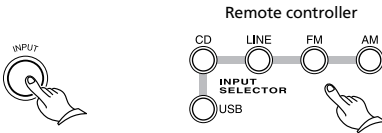

The name of the selected source appears on the display. The CD indicator CD appears when CD is selected.

### Setting the volume

The volume can be set by using either the CR-N1 or the remote controller.

**1** To set the volume, use the **VOLUME UP / DOWN (▼/▲)** buttons on the **CR-N1** or remote controller.

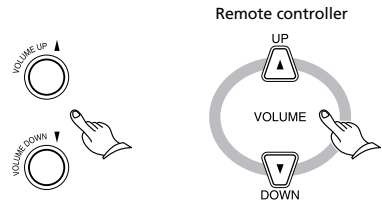

Use the **VOLUME UP (▲)** button to increase the volume, and the **VOLUME DOWN (▼)** button to decrease it. The volume level setting is shown on the display for four seconds.

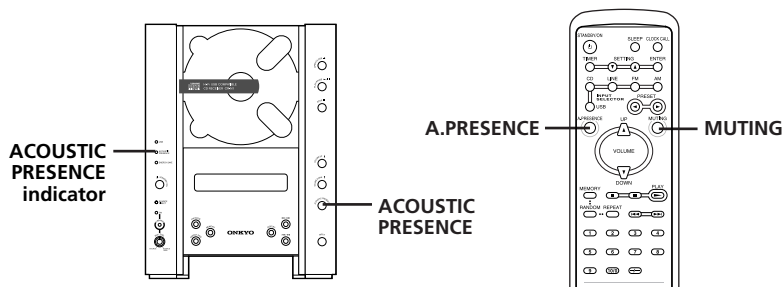

## Muting the output

Sound output can be muted temporarily by using the Muting function.

- 1 Press the **MUTING** button on the remote controller (the output is muted and the **MUTING** indicator flashes).

Remote controller

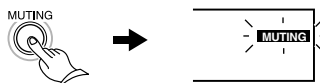

- 2 To unmute the output, press the **MUTING** button again (sound output is restored and the **MUTING** indicator stops flashing).

Alternatively, the output can be unmuted by pressing the **VOLUME UP/DOWN** (▼/▲) buttons on the CR-N1 or remote controller.

## Using Acoustic Presence

The Acoustic Presence function adds super-bass reality to music sources, increasing your listening pleasure.

- 1 Press the **ACOUSTIC PRESENCE** button on the CR-N1, or the **A.PRESENCE** button on the remote controller repeatedly to cycle through the Acoustic Presence settings.

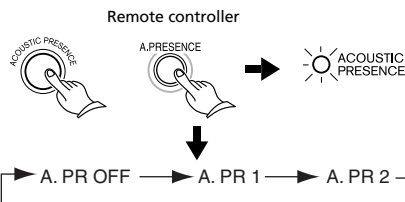

The **ACOUSTIC PRESENCE** indicator lights up while either **A. PR 1** or **A. PR 2** is selected.

**A. PR 2** provides a more pronounced effect than **A. PR 1**.

- 2 To turn off the Acoustic Presence function, select **A.PR OFF** (the **ACOUSTIC PRESENCE** indicator goes out).

# Playing CDs

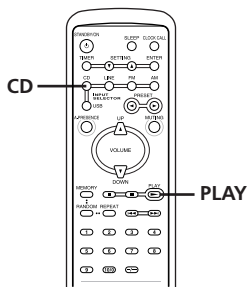
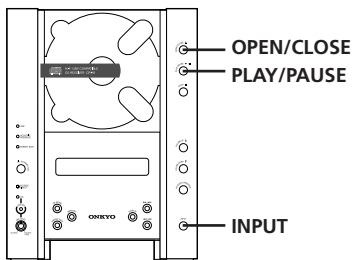

## Loading discs

The CR-N1 features a vertical disc loading compartment.

- 1 To open the disc compartment, press the OPEN/CLOSE (▲) button on the CR-N1 (the door slides open).



- 2 Mount the CD onto the spindle with the labelled side facing forwards as shown.

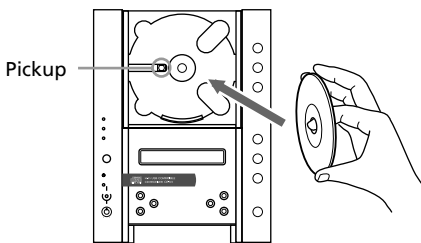

Make sure that the disc is mounted securely.

Do not touch the pickup lens. Doing so may cause a malfunction.

- 3 To close the disc compartment, press the OPEN/CLOSE (▲) button again.

To unload a disc, press the OPEN/CLOSE (▲) button, wait until the disc compartment door is fully open, and then remove the disc.

## Starting playback

- 1 To select the CD input source, press the INPUT button on the CR-N1 repeatedly until "CD" appears on the display, or press the CD button on the remote controller (the CD indicator appears).

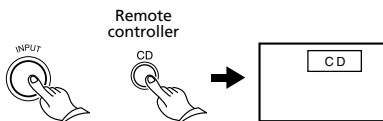

- 2 To start CD playback, press the PLAY/PAUSE (▶/||) button on the CR-N1, or the PLAY (▶) button on the remote controller (the play indicator appears).

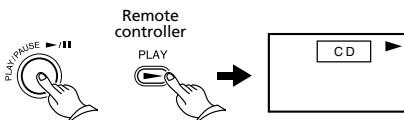

Playback commences with the first track and stops automatically when all tracks have been played.

If the CR-N1 is in Standby mode and there's a CD in the disc compartment, the CR-N1 turns on automatically, selects CD as the input source, and starts playback when the PLAY/PAUSE (▶/||) button is pressed.

If the input source is changed during CD playback, playback stops.

The Volume, Muting, and Acoustic Presence functions can all be used with CD playback.

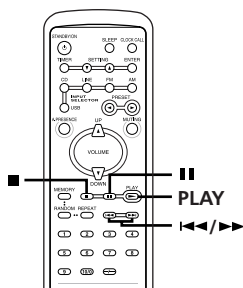
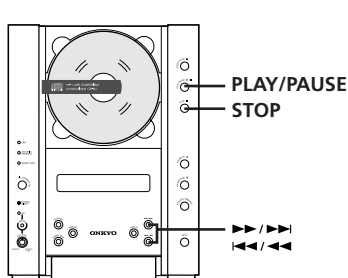

## Pausing playback

- 1 To pause CD playback, press the **PLAY/PAUSE** (▶/||) button on the CR-N1, or the **PAUSE** (||) button on the remote controller (the pause indicator appears).

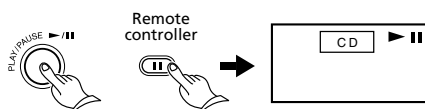

- 2 To resume CD playback, press the **PLAY/PAUSE** (▶/||) button on the CR-N1, or the **PAUSE** (||) or **PLAY** (▶) button on the remote controller (the pause indicator disappears).

## Stopping playback

- 1 To stop CD playback, press the **STOP** (■) button on the CR-N1, or the **STOP** (■) button on the remote controller (the play indicator disappears).

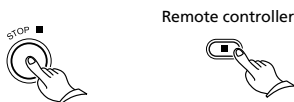

## Selecting tracks

Tracks can be selected during playback or while playback is stopped by using the Previous (◀◀/◀) and Next (▶/▶▶) buttons, or the numeric keypad on the CR-N1 or remote controller.

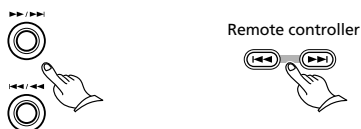

- 1 To select the next track, press the **Next** (▶/▶▶) button. Press repeatedly to select subsequent tracks.
- 2 To return to the beginning of the current track, press the **Previous** (◀◀/◀) button. Press repeatedly to select preceding tracks.

When you select tracks while playback is stopped or paused, you'll need to press the **PLAY/PAUSE** (▶/||) button on the CR-N1, or the **PLAY** (▶) button on the remote controller to start playback.

Note that it may take a few moments to start playback when playing discs that contain many tracks.

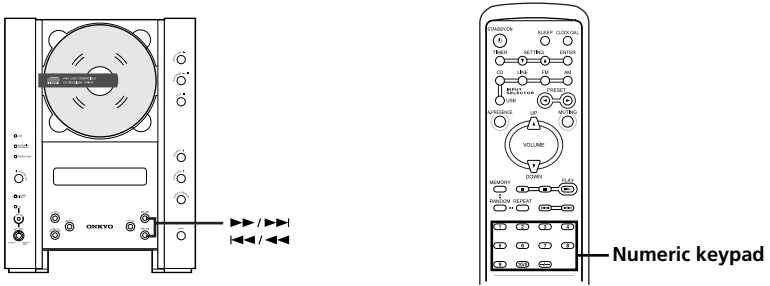

### 3 Tracks can also be selected by using the numeric keypad.

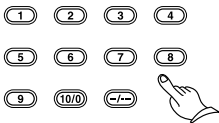

Use buttons 1 to 9 to select tracks 1 to 9. Use button 10/0 to select track 10. To select track 11 and upwards, press the --/-- button followed by the corresponding two number buttons.

Examples:

To select track 5: press **5**

To select track 10: press **10/0**

To select track 15: press **--/--** → **1** → **5**

Playback starts automatically when tracks are selected by using the numeric keypad.

### Searching tracks

You can search tracks during playback or while playback is paused by using the Review (|◀◀/◀◀) and Preview (▶▶/▶▶) buttons on the CR-N1.

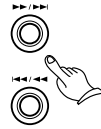

- 1** To search forwards, press and hold the Preview (▶▶/▶▶) button. Release to resume playback or pause.
- 2** To search backwards, press and hold down the Review (|◀◀/◀◀) button. Release to resume playback or pause.

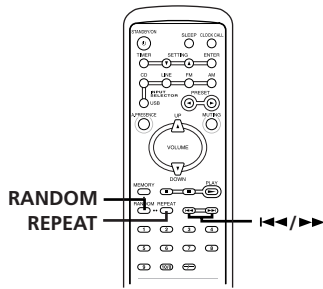

### Random playback

CD tracks are normally played in sequential order. With Random Playback, tracks are played in a random order.

- 1 To start Random Playback, press the RANDOM button on the remote controller (the RANDOM indicator appears and playback starts after a few seconds).**

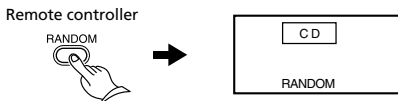

- 2 To select another track randomly, press the Next (▶▶ / ▶▶▶) button.**

When all the tracks have been played, Random playback stops.

- 3 To cancel Random Playback, press the RANDOM button (the RANDOM indicator disappears).**

Random Playback is cancelled when the STOP button is pressed, another input source is selected, or Standby mode is selected.

By combining Random playback with Memory Playback, you can play memorized tracks in a random order. See “Memory playback” on page 39 for more information. Random playback can also be combined with Repeat Playback.

### Repeat playback

CD playback normally stops once the last track has been played. With Repeat Playback, the CD is played repeatedly.

- 1 To select Repeat Playback, press the REPEAT button on the remote controller (the REPEAT indicator appears).**

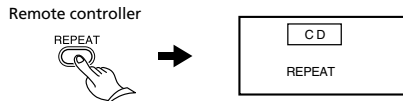

- 2 Start CD playback as normal.**

- 3 To cancel Repeat Playback, press the REPEAT button again (the REPEAT indicator disappears).**

By combining Repeat playback with Memory Playback, you can play memorized tracks repeatedly. See “Memory playback” on page 39 for more information. Repeat playback can also be combined with Random Playback.

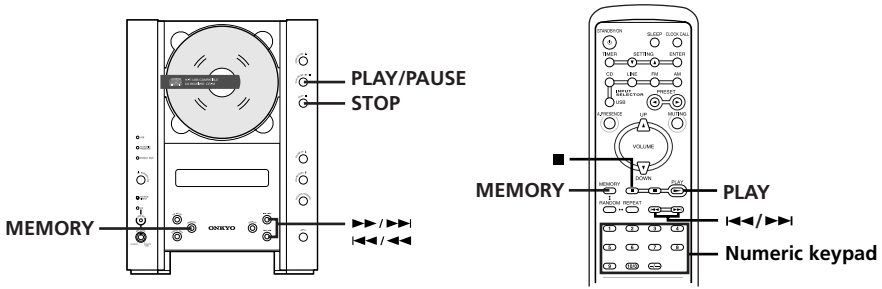

### Memory playback

CD tracks are normally played in sequential order. With Memory Playback, you can choose the playback order of up to 20 tracks.

**1** With playback stopped, press the **MEMORY** button on the CR-N1 or remote controller (the **MEMORY** indicator appears). Note that tracks can be memorized using the numeric keypad during playback, in which case it's not necessary to stop playback before pressing the **MEMORY** button. When the **MEMORY** button is pressed during playback, the current track is automatically memorized.

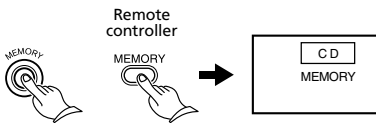

**2** Use the **Next** (▶▶/▶▶) and **Previous** (◀◀/◀◀) buttons to select the first track and then press the **MEMORY** button. Alternatively, use the numeric keypad on the remote controller to memorize tracks directly, eliminating the need to press the **MEMORY** button.

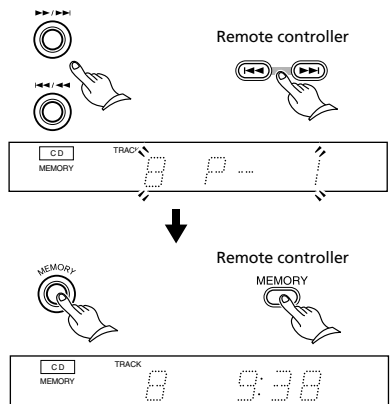

### Remote controller (direct memory entry)

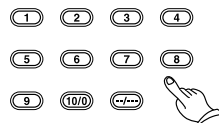

The selected track is memorized and its program number flashes on the display for a few seconds.

**3** Repeat step 2 to memorize further tracks. The program number increments as each track is memorized. The message "FULL" appears if you attempt to memorize more than 20 tracks.

**4** To remove the last memorized track, press the **STOP** (■) button. Press again to remove the track before that and so on.

**5** Once you've memorized all your tracks and are ready to start playback, press the **PLAY/PAUSE** (▶/||) button on the CR-N1, or the **PLAY** (▶) button on the remote controller.

Tracks are played in the order memorized, and playback stops when the last memorized track has been played.

**6** To stop Memory Playback, press the **STOP** (■) button.

To start Memory Playback again, press the **PLAY/PAUSE** (▶/||) button again.

**7** To cancel Memory Playback, press the **MEMORY** button (the **MEMORY** indicator disappears).

The memory contents are stored until the CD is ejected or the CR-N1 is turned off.

Memory Playback can be combined with Random Playback, so that memorized tracks play in a random order. Memory Playback can also be combined with Repeat Playback, so that memorized tracks play repeatedly. In fact, Memory Playback can be combined with both Random Playback and Repeat Playback, so that memorized tracks play in a random order repeatedly.

### Displaying track times & program numbers

In addition to displaying the elapsed time of the track currently playing, you can also check the remaining time of the current track, the entire disc, or memorized tracks in Memory Playback. In Memory Playback, you can also check the current program number.

**1** Press the **CR-N1 DISPLAY** button repeatedly to cycle through the following options.

CD stop:

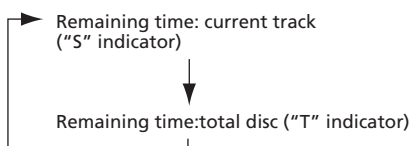

CD play/pause:

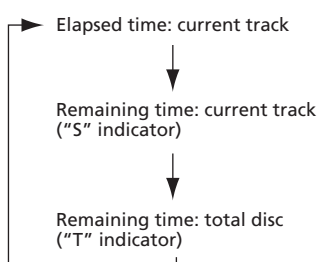

Memory Playback:

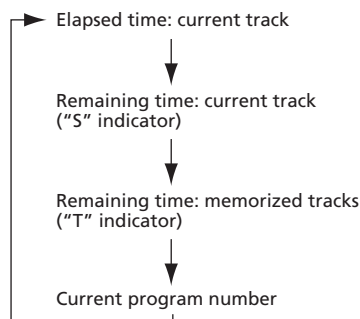

If the number of the track currently playing is higher than 20, or the total play time of the program is greater than 99 minutes and 59 seconds, "--:--" may appear on the display.



# Listening to the radio

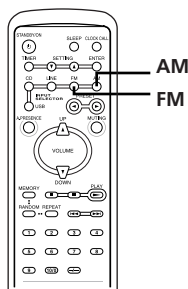
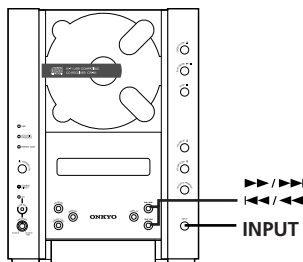

You must connect the antenna in order to use the radio. See "Connecting an AM antenna" on page 23 and "Connecting an FM antenna" on page 24 for information.

## Tuning the radio

- 1 To select either FM or AM, press the INPUT button on the CR-N1 repeatedly until "FM" or "AM" appears on the display, or press the FM or AM button on the remote controller.

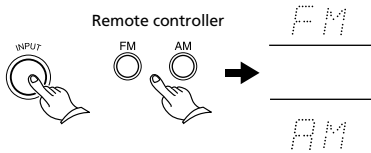

- 2 For FM stations: press and hold a Tuning (◀◀/▶▶) button for more than half a second and then release it. The CR-N1 searches for the next station. While the frequency value is still flashing on the display, if necessary, use the Tuning (◀◀/▶▶) buttons to fine tune the station in small steps. The Tuning (▶◀) indicator appears when a station is properly tuned.

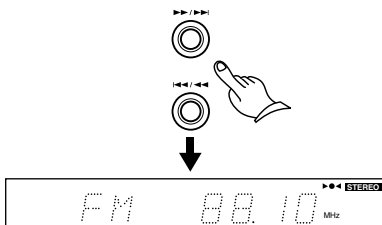

- 3 For AM stations: press and hold a Tuning (◀◀/▶▶) button for more than half a second to start tuning, then release when the desired frequency is reached. While the frequency value is still flashing on the display, use the Tuning (◀◀/▶▶) buttons to fine tune the station in small steps. The Tuning (▶◀) indicator appears when a station is properly tuned.

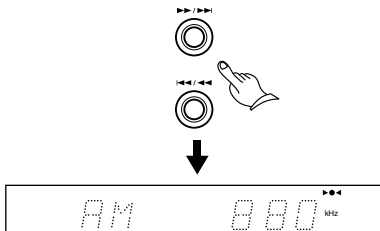

Note that once the frequency value stops flashing, pressing the Tuning (◀◀/▶▶) buttons selects the presets, not the frequency. In order to adjust the frequency, you must press and hold the Tuning (◀◀/▶▶) buttons for more than half a second.

The Volume, Muting, and Acoustic Presence functions can all be used with the radio.

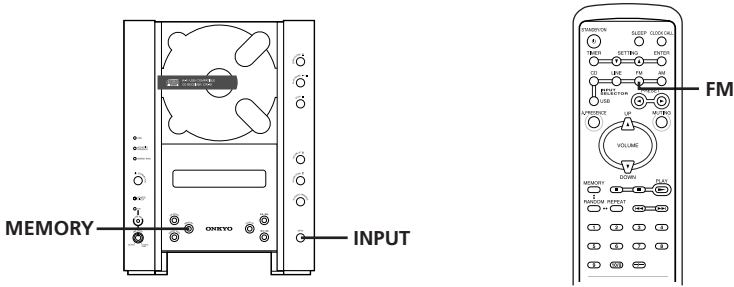

### Presetting FM stations automatically

The FM Auto function searches for all receivable FM stations and assigns them to presets automatically.

Note that previously stored presets will be overwritten by this function.

- 1 Select FM by pressing the INPUT button on the CR-N1 repeatedly until "FM" appears on the display, or press the FM button on the remote controller.

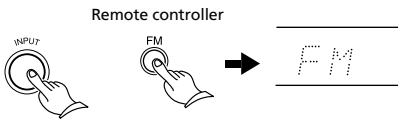

- 2 Press and hold down the MEMORY button until the frequency value begins to change (the MEMORY indicator appears). Note that you must hold down the MEMORY button until after "AUTO" stops flashing).

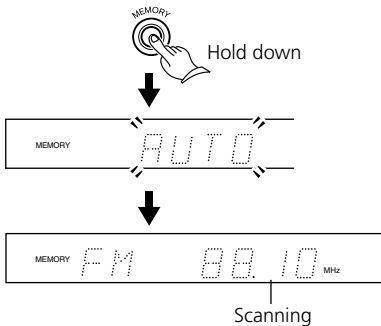

The entire FM frequency band is scanned from low to high and up to 30 stations are assigned to the presets automatically. The process is complete when the frequency value stops changing.

### Presetting FM/AM stations manually

You can store up to 30 of your favorite AM and FM radio stations as presets.

- 1 Tune into the station that you want to store as a preset.

See "Tuning the radio" on page 41 for more information.

- 2 Press the MEMORY button (the MEMORY indicator appears and "--" flashes).

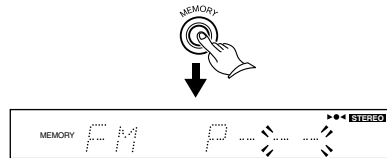

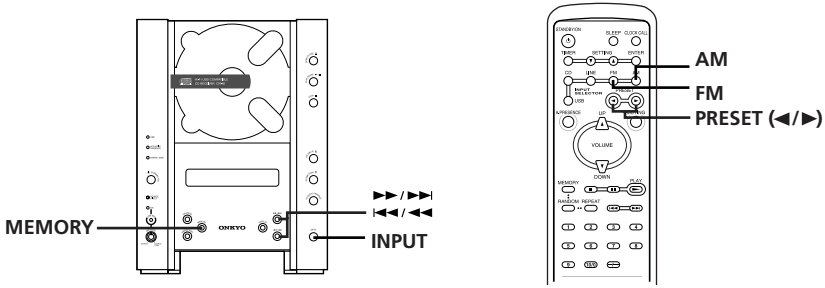

**3** While “--” is flashing, use the Tuning (◀◀/◀/▶/▶▶) buttons to select a preset from 1 through 30.

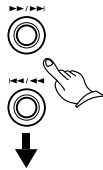

When you select a preset that already contains a station, the preset number flashes quickly. You can overwrite such presets by continuing with this procedure. Alternatively, select an available preset.

**4** While the preset number is flashing, press the MEMORY button to store the selected preset (the MEMORY indicator disappears and the preset number stops flashing).

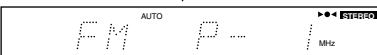

Note that you must press the MEMORY button while the preset number is flashing, otherwise, you'll have to start the procedure again at step 2.

The message “FULL” appears if you attempt to store more than 30 presets.

If the tuned FM station supports RDS Program Service Names (PS), the station's name is displayed instead of its frequency.

### Selecting preset stations

Preset stations can be selected as follows.

**1** To select either FM or AM, press the INPUT button on the CR-N1 repeatedly until “FM” or “AM” appears on the display, or press the FM or AM button on the remote controller.

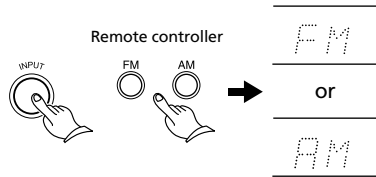

**2** Use the Tuning (◀◀/◀/▶/▶▶) buttons, or the PRESET (◀/▶) buttons on the remote controller to select the presets.

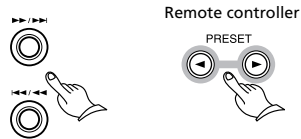

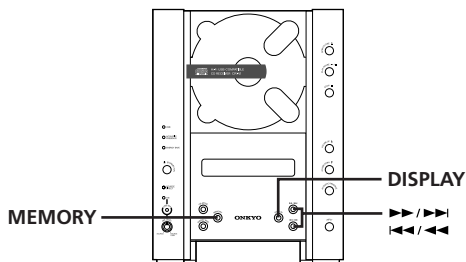

## Naming presets

Presets can be named using up to eight characters as follows.

- 1 Select the preset that you want to name. See "Selecting preset stations" on page 43 for more information.
- 2 Press and hold the DISPLAY button until the flashing cursor appears "-".

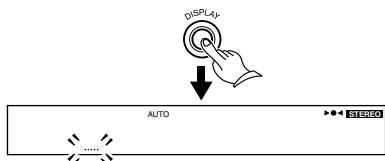

- 3 Use the Tuning (|<<</>>>|) buttons to select characters.

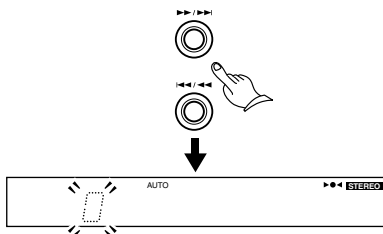

The following 54 characters are available:

A B C D E F G H I J K L M N O P Q R S  
 T U V W X Y Z " & ' ( ) \* + , - . / = ? [ \ ]  
 0 1 2 3 4 5 6 7 8 9 Space

- 4 Press the MEMORY button to set the character and move the cursor to the next position.

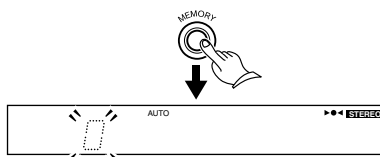

You can enter spaces by pressing the MEMORY button.

- 5 When you've finished, press and hold down the DISPLAY button for two seconds, or select the rightmost character and then press the MEMORY button.

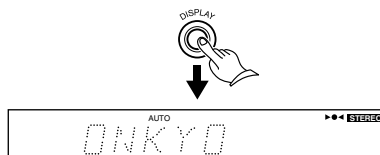

If you don't press any buttons for 16 seconds during this procedure, the function completes automatically.

FM stations that support RDS Program Service Names (PS) cannot be named.

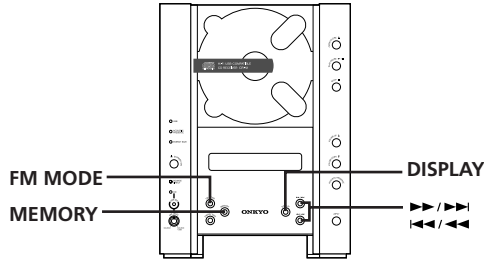

### Editing preset names

You can edit preset names as follows.

- 1** Select the preset whose name you want to edit.  
See "Selecting preset stations" on page 43 for more information.
- 2** Press and hold the DISPLAY button until the first character of the name starts flashing.
- 3** To delete the entire name, press and hold the MEMORY button and then press the FM MODE button.
- 4** Use the MEMORY button to select the character that you want to edit.
- 5** Use the Tuning (◀◀/▶▶) buttons to edit the character, and then press the MEMORY button to set the character and move the cursor to the next position.
- 6** When you've finished, press the hold down the DISPLAY button for two seconds.

### Deleting presets

You can delete presets as follows.

- 1** Select the preset that you want to delete.  
See "Selecting preset stations" on page 43 for more information.
- 2** Press and hold the MEMORY button and then press the FM MODE button.



You must press the FM MODE button soon after pressing the MEMORY button, otherwise the FM Auto function will start.

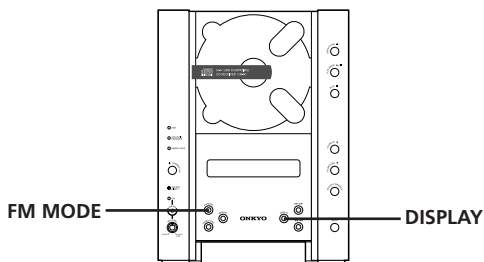

### Listening to stereo broadcasts

There are two FM radio modes: Auto and Mono. In Auto mode, the CR-N1 automatically switches to Stereo mode if the signal strength of tuned FM station is strong enough. In this case, the STEREO indicator appears. If the signal is not strong enough, stereo reception may be noisy and the STEREO indicator may flash. In this case, you may prefer to listen in Mono mode.

**1 Use the FM MODE button to select the FM mode: Auto or Mono.**

The AUTO indicator appears when Auto mode is selected, and the MONO indicator appears when Mono mode is selected.

### Using RDS (European models)

RDS is only available with European models and in areas where RDS broadcasts are available. The CR-N1 supports RDS Program Service Names (PS). When an FM station that supports RDS Program Service Names (PS) is tuned properly, that station's name can be displayed in addition to its frequency. In this case, the RDS indicator appears on the display.

**1 Use the DISPLAY button to toggle the display between the station name and its frequency.**

For named presets, the name you specified appears instead of the station name.

In areas where the signal strength is weak, the RDS information may not be displayed.

# Using the timer (remote controller only)

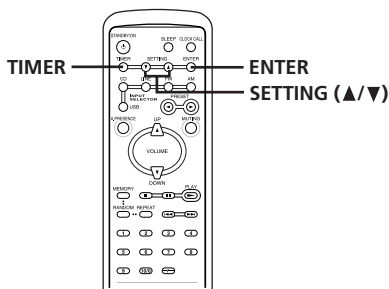

The timer can be used to automatically turn on and off the CD player or radio at a specified time. You can set independent on and off times for weekdays and weekends, configure which days are weekdays and which are weekend days, and turn each timer on or off independently. The sleep timer can be used to automatically turn off the CR-N1 after a specified amount of time.

Note that you must set the clock in order to use the timer. See "Setting the clock" on page 31 for information.

If you want to use the timer to turn on the radio, you must preset the station that you want to listen to beforehand. See "Presetting FM stations automatically" on page 42 and "Presetting FM/AM stations manually" on page 42 for information.

## Programming the timer

The timer is programmed by using the remote controller.

- 1 Press the **TIMER** button repeatedly to select the **WEEKDAY** or **WEEKEND** timer, and then press the **ENTER** button.

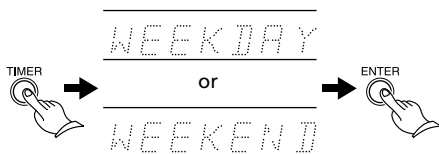

If you selected the Weekday timer, "W.DAY" appears on the display, and if you selected the Weekend timer, "W.END" appears.

- 2 Use the **SETTING (▼/▲)** buttons to set the **ON** time, and then press the **ENTER** button.

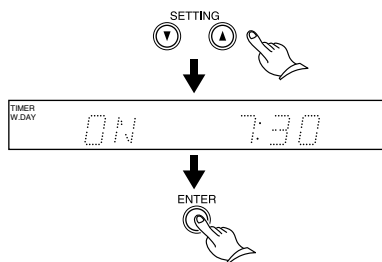

- 3 Use the **SETTING (▼/▲)** buttons to set the **OFF** time, and then press the **ENTER** button.

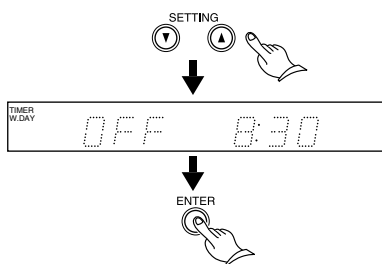

- 4 Use the **SETTING (▼/▲)** buttons to select the source (i.e., CD, LINE, USB, FM, or AM) that you want to use with the timer, and then press the **ENTER** button.

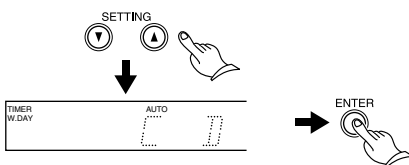

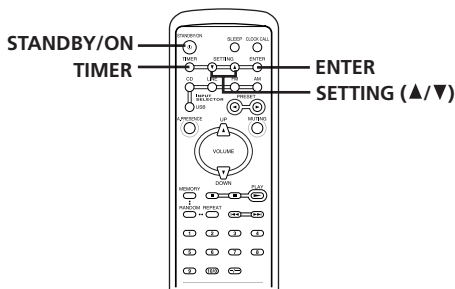

**5** If you selected the FM or AM source, use the SETTING (▼/▲) buttons to select a preset station.

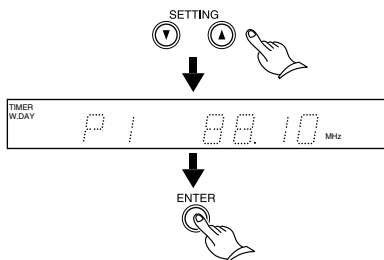

**6** Press the STANDBY/ON button to enter Standby mode.



At the specified ON time, the CR-N1 will automatically turn on and play the specified source. Make sure that the volume is set at an appropriate level, and if you've programmed the timer for CD playback, don't forget to load a disc. At the specified OFF time, the CR-N1 will automatically turn itself off.

If you configure a day as both a weekday and a weekend day, for example, to turn the CR-N1 on and off twice on that day, leave at least one minute between the first timer's OFF setting and the second timer's ON setting. If the second timer's ON setting occurs before the first timer's OFF setting, the second timer's settings will be ignored.

If the sleep timer function is turned on during a timer's ON-OFF period, the

CR-N1 will automatically enter Standby mode after the specified sleep time has elapsed, ignoring the timer's OFF setting. The timer still works when the Energy Save function is on.

### Turning the timers on & off

The timers can be turned on and off independently as follows.

Note that a timer cannot be turned on unless it has been programmed.

**1** Press the TIMER button repeatedly to select the WEEKDAY or WEEKEND timer.

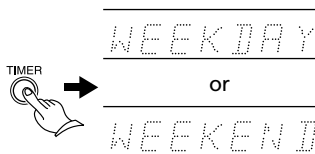

**2** Use the SETTING (▼/▲) buttons to turn the timer on or off, and then press the ENTER button.

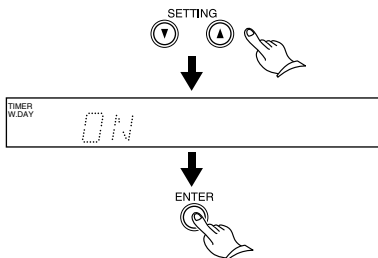

When the Weekday timer is on, "W.DAY" is displayed, and when the Weekend timer is on, "W.END" is displayed.



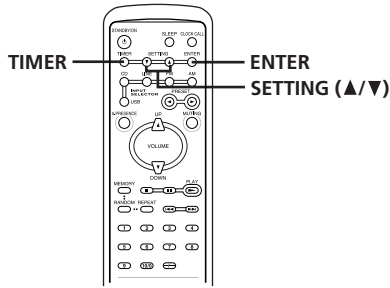

### Configuring weekdays & weekends

You can configure days as weekdays, weekend days, or both. Configuring days as both allows you to turn the CR-N1 on and off twice on such days.

Initially, Monday through Friday are configured as weekdays, and Saturday and Sunday, as weekend days, as shown.

#### Initial factory configuration

WEEKDAY:

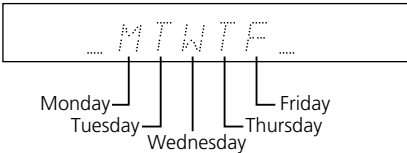

WEEKEND:

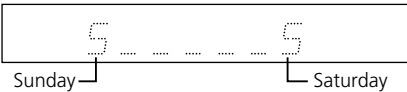

- 1 Press the **TIMER** button repeatedly to select **DAY SET**, and then press the **ENTER** button.

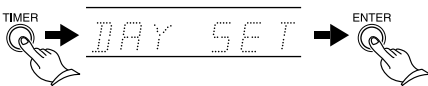

- 2 Use the **SETTING (▼/▲)** buttons to select **WEEKDAY** or **WEEKEND**, and then press the **ENTER** button.

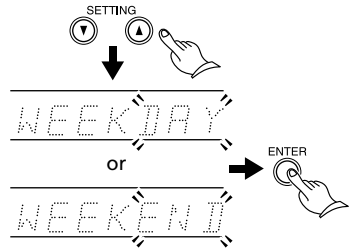

The current configuration for the selected timer appears.

- 3 Use the **SETTING (▼/▲)** buttons to turn the first day on or off, and then press the **ENTER** button to set that day and move the cursor to the next position.

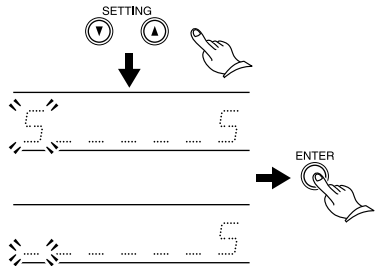

- 4 Repeat step 3 until all days have been configured, and then press the **ENTER** button.

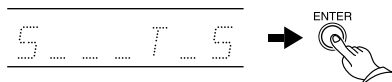

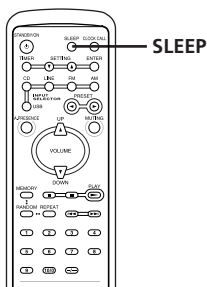

## Using the sleep timer

The sleep timer automatically turns off the CR-N1 after a specified amount of time.

- 1 Turn on the CR-N1 and play a CD, radio station, or other source.**
- 2 Press the SLEEP button repeatedly to set the required sleep time (the SLEEP indicator appears).**

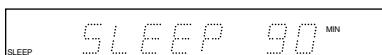

The sleep time can be set from 10 to 90 minutes in 10-minute steps.

After the specified sleep time has elapsed, the CR-N1 will automatically enter Standby mode.

You can check the remaining sleep time by pressing the SLEEP button.

The sleep timer can be turned off by pressing the SLEEP button repeatedly until the SLEEP indicator disappears.

# Using USB

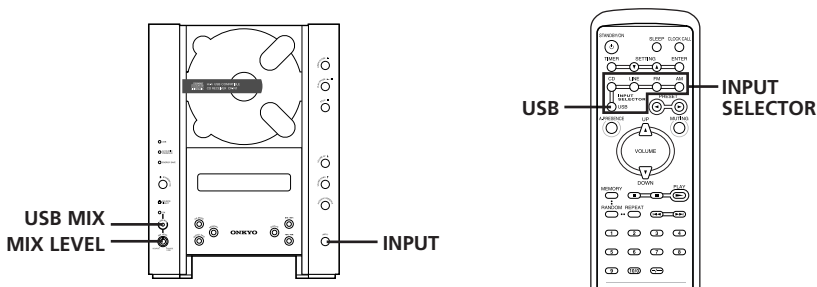

By connecting the USB port on your computer to the USB port on the CR-N1, you can listen to music and other sounds from your computer with high quality. Before connecting your computer to the USB port, see “Windows USB setup” on page 52 or “Macintosh USB setup” on page 56.

Note: If you turn the CR-N1 on or off, or connect or disconnect the USB cable while your computer is outputting sound (e.g., playing back audio), or while launching audio playback software, your computer may become unstable. Always quit audio playback software before turning the CR-N1 on or off, or before connecting or disconnecting the USB cable.

If the CR-N1 is turned on or off frequently, or the USB cable connected or disconnected frequently while your computer is up and running, in some cases your computer may stop operating normally. In this case, you should restart your computer.

## Mixing USB with other sources

The USB Mix function allows you to mix audio from the CD, LINE, FM, or AM source with audio from the USB port, which means that you can still hear computer system sounds while listening to your favorite CDs or radio stations.

- 1 Press the **INPUT** button on the CR-N1 repeatedly, or use the **CD, LINE, FM, or AM INPUT SELECTOR** buttons on the remote controller to select the required input source.

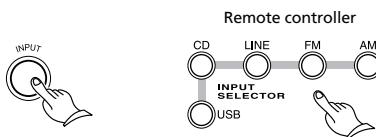

- 2 Press the **USB MIX** button on the CR-N1 (the **USB MIX ON** indicator lights up and the **SOURCE DIRECT** indicator goes out).



- 3 Use the **USB MIX LEVEL** control to set the level of the USB signal.



## Listening to computer audio

- 1 To select the USB input source, press the **INPUT** button on the CR-N1 repeatedly until “USB” appears on the display, or press the **USB** button on the remote controller.

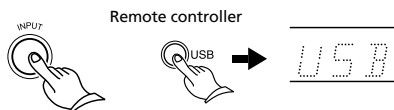

The Volume, Muting, and Acoustic Presence functions can all be used with USB sources.

Turn the USB MIX LEVEL control counter-clockwise to increase the level of the selected source, and turn it clockwise to increase the level of the USB source.

Continued...

**4** To turn off the USB Mix function, press the **USB MIX** button again (the **USB MIX ON** indicator goes out and the **SOURCE DIRECT** indicator lights up).

The USB Mix can be heard through the speakers and headphones, but only the selected source signal is output from the LINE OUT.

### Windows USB setup

The CR-N1 USB interface supports “hot plugging,” so USB cables can be connected or disconnected even while your PC is on.

However, it’s recommended that you turn down the CR-N1 volume beforehand.

Use only standard USB cables that support high-speed transmission.

The following procedures and screen shots are based on Windows Me. Additional screen shots are provided where differences exist between operating systems.

### System requirements

- Windows-compatible PC with a Rev. 1.0 compatible USB port.
- Windows 98, 98SE, Me, 2000 or later operating system that supports USB.

See your computer manual or consult your dealer to ensure that your PC complies with these requirements.

### Checking your PC’s USB ports

Before connecting the CR-N1, it’s a good idea to check that your PC’s USB ports are working properly.

**1** From the Start menu, select **Settings** → **Control panel**, and open the **System control panel**.

**2** Click the **Device Manager** tab, and then click the “**View devices by type**” button.

**3** Click the plus box next to “**Universal Serial Bus controllers**.”

Under “**Universal Serial Bus controllers**,” you should see several USB devices listed, as shown here.

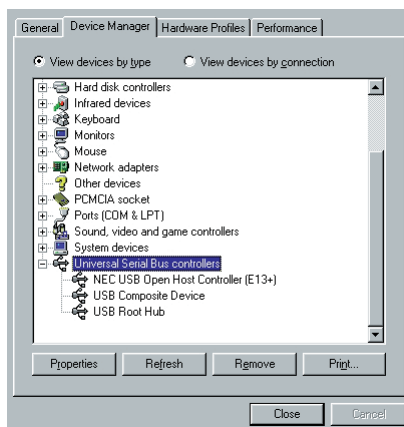

Note that the device list you see on your PC will no doubt be different to that shown here due to PC specification and operating system differences. In addition, the type of USB Host Controller will be different.

A letter X, exclamation point (!), or question mark (?) to the left of a USB device name indicates that the USB device is not functioning properly. For information on how to correct this, see your computer manual or consult your dealer.

## Connecting the CR-N1 (driver installation)

- 1 Turn on your PC and wait until the Windows startup is complete.
- 2 Connect the USB cable from the CR-N1 to a USB port on your PC.

The CR-N1's USB indicator lights up. If the USB indicator does not light, make sure that the USB cable is connected correctly between the CR-N1 and PC.

Note that it may take up to 10 seconds for your PC to recognize the CR-N1. Do not disconnect the CR-N1 during this time.

The first time the CR-N1 is connected to your PC, Windows automatically detects that a new hardware device has been connected and proceeds to install the necessary driver software. Follow the prompts on-screen. You may need your original Windows disc to complete the installation.

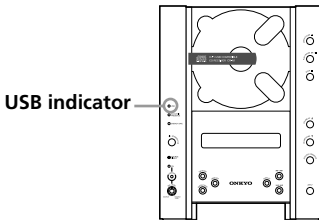

## Verifying driver installation

After installing the necessary drivers, verify that they have been installed correctly as follows.

- 1 Open the System control panel, click the Device Manager tab (if you are using Windows 2000 you'll need to click the Hardware tab first), and make sure that "USB Audio Device" appears under "Sound, video and game controllers" as shown.

## Windows 98/98SE/Me

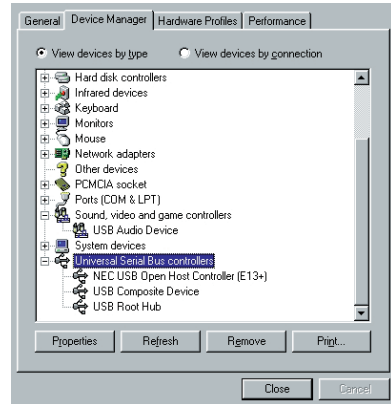

## Windows 2000

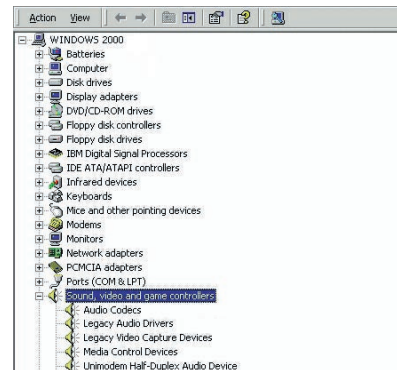

Note that the device list you see on your PC will no doubt be different to that shown here due to PC specification and operating system differences.

If "Unknown device" appears under "Universal Serial Bus controllers," disconnect the USB cable from the CR-N1, reconnect it, and then check again. If it's still not recognized, disconnect the USB cable again, and this time delete the "Unknown device" from the list, then reconnect the USB cable. If it's still not recognized, it's possible that your PC has become unstable, in which case you should restart it, delete the "Unknown device" from the list, then reconnect the USB cable. If that doesn't work, there may be a problem with the USB port, in which case you should consult your PC dealer.

## Checking audio output & volume control operation

For correct operation, check the Windows audio output and volume control settings as follows.

- 1 Open the Multimedia control panel.**  
The Multimedia Properties control panel opens.
- 2 On the Audio panel, make sure that the "Preferred device" for Playback is set to USB Audio Device, as shown.**

### Windows 98/98SE

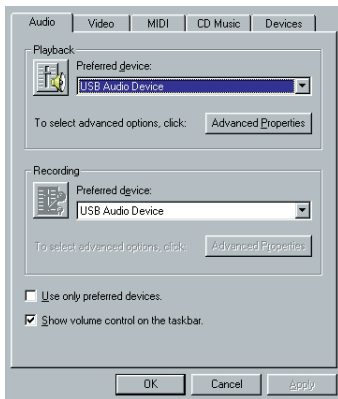

### Windows 2000/Me



- 3 If you are using Windows 98/98SE, click the Playback button. If you are using Windows 2000/Me, click the Volume button.**

The Volume Control opens, as shown.

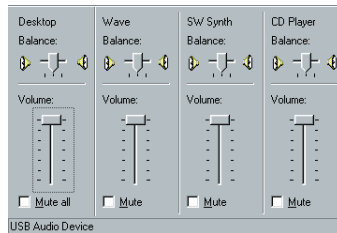

- 4 Set the Volume slider for each device to maximum, close the window, and then click OK to close the Multimedia control panel.**

## Enabling digital CD audio

In order to listen to CDs in your computer's CD-ROM drive via USB, you must enable digital CD audio for your CD-ROM drive as follows.

### Windows 98/98SE

- 1 Open the Multimedia control panel and click the CD Music tab.

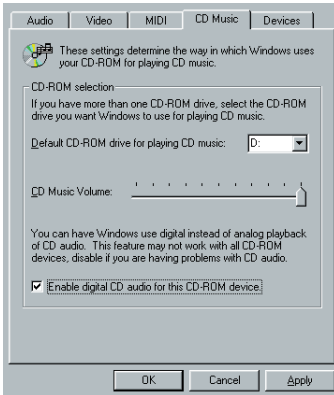

- 2 Select the "Default CD-ROM drive for playing CD music."
- 3 Turn on "Enable digital CD audio for this CD-ROM device."
- 4 Click OK to close the control panel.

### Windows 2000/Me

- 1 Open the System control panel.
- 2 If you are using Windows 2000, click the Hardware tab, and then click the Device Manager. If you are using Windows Me, click the Device manager tab.
- 3 Select your CD-ROM drive from the list, and then click the Properties button.
- 4 Click the Properties tab, and then turn on "Enable digital CD audio for this CD-ROM device."

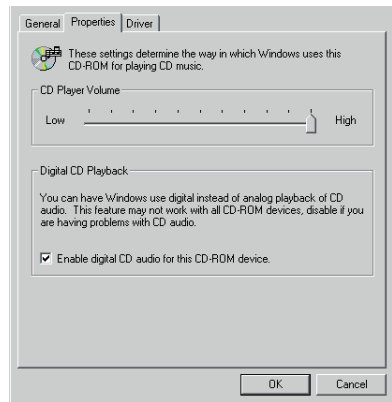

- 5 Click OK to close the window, and then close the System control panel.
- Note that if the CR-N1 has not been recognized successfully by your PC, or your CD-ROM drive does not support digital audio output, you will not be able to turn on "Enable digital CD audio for this CD-ROM device."

## Macintosh USB setup

The CR-N1 USB interface supports “hot plugging,” so USB cables can be connected or disconnected even while your Macintosh is on. However, it’s recommended that you turn down the CR-N1 volume beforehand.

Use only standard USB cables that support high-speed transmission.

Operation cannot be guaranteed when using USB ports that are not standard equipment (e.g., USB ports on a third-party PCI interface card).

The following procedures and screen shots are based on Mac OS 9.0. Additional screen shots are provided where differences exist between operating systems.

### System requirements

- iMac, iBook, or Power Macintosh or PowerBook with a built-in USB port.
- Mac OS 9.0 or later Mac OS that supports USB.

See your computer manual or consult your dealer to ensure that your Macintosh complies with these requirements.

### Connecting the CR-N1

- 1 Turn on your Macintosh and wait until the Mac OS startup is complete.
- 2 Connect the USB cable from the CR-N1 to a USB port on your Macintosh. The CR-N1’s USB indicator lights up. If the USB indicator does not light, make sure that the USB cable is connected correctly between the CR-N1 and Macintosh.

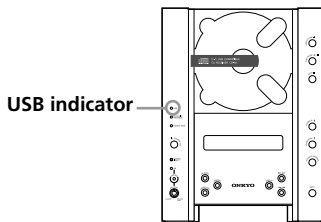

### Verifying that the CR-N1 is recognized

After connecting the CR-N1, you should verify that it has been recognized by your Macintosh.

- 1 Choose **Apple System Profiler** from the **Apple** menu.
- 2 Click the **Devices & Volumes** tab.
- 3 Verify that “**Burr-Brown Japan PCM2702**” is listed as a USB device, as shown.

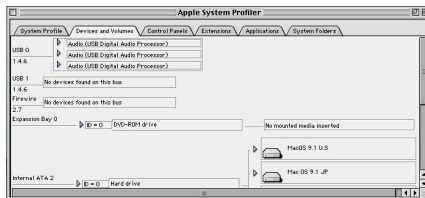

Note that the device list you see on your Macintosh will no doubt be different to that shown here due to configuration and system differences.



## Sound control panel confirmation

In order to output audio from your Macintosh via USB, you must set the audio output as follows.

- 1 Open the Sound control panel.
- 2 Select Output, and make sure that "Choose a device for sound output:" is set to Built-in, as shown.  
Mac OS 9.0.4

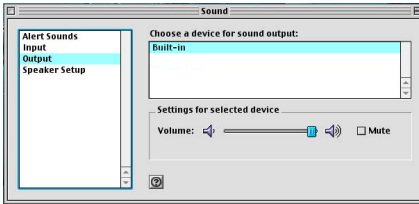

### Mac OS 9.1



- 3 Play an AIFF file or something in order to confirm that the CR-N1 is outputting sound properly.

Note that the device list you see on your Macintosh will no doubt be different to that shown here due to configuration and system differences.

If no sound is heard, disconnect the USB cable from the CR-N1, reconnect it, and then check again.

## Using Platinum Sounds

In order to listen to Platinum Sounds via USB, follow the procedure below. If you do not follow this procedure, Platinum Sounds may not work properly.

- 1 Disconnect the CR-N1 from your Macintosh's USB port.
- 2 Open the Appearance control panel.
- 3 Click the Sound tab, and set "Sound track" to None, as shown.



- 4 Reconnect the CR-N1 to your Macintosh's USB port.
- 5 Set the "Sound track" to Platinum Sounds, as shown.

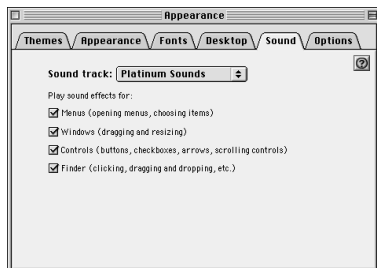

- 6 Close the Appearance control panel.

# Troubleshooting

If you are having trouble operating your CR-N1, look up the symptoms in the following table and then try the suggested remedy. If you cannot resolve the issue yourself, contact your nearest Onkyo dealer.

Symptom	Possible cause	Remedy
Cannot turn on the CR-N1.	The AC power cord is not fully inserted into the wall outlet?	Check the AC power cord and make sure that it's fully inserted into the wall outlet. See page 29.
There's no sound from the speakers.	The volume is turned down?	Adjust the volume. See page 33.
	A pair of headphones are connected to the PHONES jack?	Disconnect the headphones. See page 28.
	The output is muted by the Muting function?	Turn off the Muting function. See page 34.
Sound is coming from only one speaker.	The speakers are not connected correctly?	Check the speaker connections. See page 18.
	The quiet speaker is not connected correctly?	Check the speaker connections. See page 18.
There's no sound when the timer turns on the CR-N1.	The volume is turned down?	Adjust the volume. See page 33.
	The timer source is set to CD, but no CD is loaded?	Load a CD and try again. See page 35.
	The timer source is set to LINE or USB, but the external LINE or USB device is not working properly?	Make sure that the external LINE or USB device is working properly.
The remote controller doesn't work properly.	The batteries have expired?	Install new batteries. See page 8.
	The remote control is too far away from the CR-N1?	Try using the remote controller closer to the CR-N1. See page 8.
	There's an obstacle between the CR-N1 and the remote controller?	Remove the obstacle.
Cannot tune into AM stations.	The AM loop antenna is not connected properly?	Make sure that the AM loop antenna is connected properly. See page 23.
AM reception is hindered by a buzzing noise, especially at night and with weak signals.	Interference caused by electrical equipment, such as fluorescent lights?	Move the AM loop antenna away from electrical equipment and fluorescent lights. See page 23.
		Install an outdoor AM antenna. See page 23.
AM reception is hindered by a high-pitched noise.	Interference caused by a TV?	Move the AM loop antenna and CR-N1 away from the TV. See page 23.
AM or FM reception is hindered by a crackling noise.	Interference caused when a fluorescent light is turned on, or from motor car ignition systems?	Locate the antenna away from fluorescent lights.
		Install an outdoor FM antenna as far away as possible from any roads. See page 24.
The FM sound quality and stereo separation are poor even though the tuning and stereo indicators are displayed.	The signal is too strong?	Try an indoor FM antenna.
	Tall buildings or mountains are creating multiple radio wave reflections?	Try an FM antenna with greater directionality.

Symptom	Possible cause	Remedy
FM reception is hindered by hiss and the tuning and stereo indicators are flashing.	The received signal is too weak?	Install an outdoor FM antenna. See page 24.
	Stereo FM transmissions travel only half the distance of regular transmissions?	Try changing the position and direction of the outdoor antenna. Set the FM mode to Mono. See page 46.
The radio presets no longer work.	The AC power cord has not been connected to a wall outlet for an extended period?	The AC power cord must be plugged into a wall outlet a few times each month in order to preserve the radio presets and other settings. Reprogram the presets. See page 42.
RDS doesn't work.	The tuned station does not support RDS?	Tune into an FM station that supports RDS. Install an outdoor FM antenna. See page 24.
	The signal is too weak?	Try changing the position and direction of the outdoor FM antenna.
	There's too much interference?	Locate the FM antenna as far away as possible from any fluorescent lights. See page 24. Install an outdoor FM antenna. See page 24.
CD playback skips.	The CR-N1 is exposed to vibration?	Place the CR-N1 somewhere free from vibration.
	The disc is badly scratched?	Replace with a new disc.
	The disc is very dirty?	Clean the disc.
Tracks cannot be memorized with Memory Playback.	No disc is loaded?	Load a disc. See page 35.
	The CD doesn't contain the track number you are trying to memorize?	Memorize only available track numbers.
A disc is loaded, but playback cannot be started.	The disc is loaded the wrong way round?	Load the disc with the labeled side facing forwards. See page 35.
	The disc is very dirty?	Clean the disc.
	Condensation has formed inside the CR-N1?	Unload the disc and leave the CR-N1 for several hours until the condensation has cleared.
It takes a long time to locate specified tracks.	The disc is very dirty?	Clean the disc.
	The disc is scratched?	Replace with a new disc.
USB setup has been completed, but the "new device detected" window keeps appearing.	Windows has become unstable.	Restart your PC.

Severe electrical interference may render the CR-N1's microcomputer temporarily inoperable. In this case you should unplug the CR-N1 for at least five seconds, and then reconnect it.

# Specifications

## Amplifier

Power output (U.S. & Canadian models)	2 x 6.5 watts min., RMS at 8 ohms, 50 Hz–20 kHz, with no more than 0.6% total harmonic distortion (FTC)
	2 x 9.5 watts min., RMS at 4 ohms, 50 Hz–20 kHz, with no more than 0.8% total harmonic distortion (FTC)
	2 x 15 watts at 4 ohms (EIAJ)
Power output (Other models)	2 x 10 watts at 4 ohms, 1 kHz (DIN)
	2 x 8.5 watts at 6 ohms, 1 kHz (DIN)
	2 x 7 watts at 8 ohms, 1 kHz (DIN)
	2 x 6.5 watts min., RMS at 8 ohms, 1 kHz, no more than 0.6% THD (FTC rating)
	2 x 15 watts at 4 ohms (EIAJ)
Dynamic power	2 x 15 watts at 4 ohms
	2 x 9 watts at 8 ohms
Total harmonic distortion	0.4% at 5 watts output into 4 ohms, 1 kHz
IM distortion	0.4% at 5 watts output into 4 ohms, 1 kHz
Damping factor	25 at 4 ohms
	50 at 8 ohms
LINE IN sensitivity and impedance	500 mV, 47k $\Omega$
Frequency response	10 Hz–20 kHz, +3/–3 dB
Acoustic presence	1: +6.0 dB at 80 Hz
	2: +10.0 dB at 80 Hz
Signal to noise ratio	95 dB (IHF-A)
Muting	–50 dB

## CD Player

Signal readout system	Optical non-contact
Reading rotation	Approx. 500–200 rpm (constant linear velocity)
Linear velocity	1.2–1.4 m/s
Error correction system	Cross interleave Reed Solomon code
D/A converter	1 bit
Digital filter	352.8 kHz, 8-times oversampling
Number of channels	2 (stereo)
Frequency response	5 Hz–20 kHz
Wow & flutter	Below threshold of measurability

## USB

Connection method	USB (Universal Serial Bus) Ver 1.1
Sampling rate (input)	32/44.1/48 kHz compatible
Frequency response	5 Hz–20 kHz

**Tuner**

Tuning range	FM	87.9–107.9 MHz (200 kHz steps) (U.S. & Canadian model)	
		87.5–108.00 MHz (50 kHz steps) (Other area models)	
	AM	530–1710 kHz (10 kHz steps) (U.S. & Canadian model)	
		522–1611 kHz (9 kHz steps) (European & Australian models)	
		531–1602 kHz (9 kHz steps) (Asian models)	
Usable sensitivity	FM	Mono	11.2 dBf, 1.0 $\mu$ V (75 ohms IHF)
			11.2 dBf, 0.9 $\mu$ V (75 ohms DIN)
	Stereo	17.2 dBf, 2.0 $\mu$ V (75 ohms IHF)	
		17.2 dBf, 23.0 $\mu$ V (75 ohms DIN)	
AM		30 $\mu$ V	
50 dB quieting sensitivity	FM	Mono	17.2 dBf, 2.0 $\mu$ V (75 ohms)
		Stereo	37.2 dBf, 20.0 $\mu$ V (75 ohms)
Capture ratio	FM	2.0 dB	
Image rejection ratio	FM	40 dB (U.S. & Canadian model)	
		85 dB (Other area models)	
AM		40 dB	
IF rejection ratio	FM	90 dB	
	AM	40 dB	
Signal to noise ratio	FM	Mono	73 dB, IHF
		Stereo	67 dB, IHF
	AM	40 dB	
Selectivity	FM	50 dB DIN ( $\pm$ 300 kHz at 40 kHz deviation)	
AM suppression ratio			50 dB
Harmonic distortion	FM	Mono	0.2%
		Stereo	0.3%
	AM		0.7%
Frequency response	FM	30 Hz–15.0 kHz ( $\pm$ 1.5 dB)	
Stereo separation	FM	35 dB at 1 kHz	
		25 dB at 100 Hz–10.0 kHz	
Stereo threshold	FM	17.2 dBf, 2.0 $\mu$ V (75 ohms)	

**General**

Power supply	AC 120 V, 60 Hz, 39 W (U.S. & Canadian model, some Asian models)
	AC 230 V, 50 Hz, 32 W (European model)
	AC 220 V, 50/60 Hz, 32 W (Other area models)
Dimensions (W x H x D)	203 x 270 x 234 mm
	8" x 10-5/8" x 9-3/16"
Weight	4.2 kg (9.3 lbs)

Specifications and features are subject to change without notice.  
 Power supply and voltage specifications depend on where the unit is purchased.

# MEMO

---

# MEMO

---

# **ONKYO CORPORATION**

Sales & Product Planning Div. : 2-1, Nisshin-cho, Neyagawa-shi, OSAKA 572-8540, JAPAN  
Tel: 072-831-8111 Fax: 072-833-5222 <http://www.onkyo-intl.com>

## **ONKYO U.S.A. CORPORATION**

18 Park Way, Upper Saddle River, N.J. 07458, U.S.A.  
Tel: 201-785-2600 Fax: 201-785-2650 <http://www.onkyousa.com>

## **ONKYO EUROPE ELECTRONICS GmbH**

Liegnitzerstasse 6, 82194 Groebenzell, GERMANY  
Tel: +49-8142-4401-0 Fax: +49-8142-4401-555 <http://www.onkyo.net>

## **ONKYO CHINA LIMITED**

Units 2102-2107, Metroplaza Tower I, 223 Hing Fong Road, Kwai Chung,  
N.T., HONG KONG Tel: 852-2429-3118 Fax: 852-2428-9039

