

ALTO-SHAAM®

Cook, Hold, Smoke Oven

Simple Control



Models:

767-SK
1767-SK
1000-SK-I
1000-SK/II



1767-SK

767-SK



1000-SK-I
SHOWN WITH OPTIONAL
BURGUNDY EXTERIOR

1000-SK/II

- **INSTALLATION**
- **OPERATION**
- **MAINTENANCE**

HALO
HEAT®

24•7
Your Service Hotline
1-800-558-8744

W164 N9221 Water Street • P.O. Box 450 • Menomonee Falls, Wisconsin 53052-0450 USA
PHONE: 262.251.3800 • 800.558.8744 USA/CANADA FAX: 262.251.7067 • 800.329.8744 U.S.A. ONLY
www.alto-shaam.com

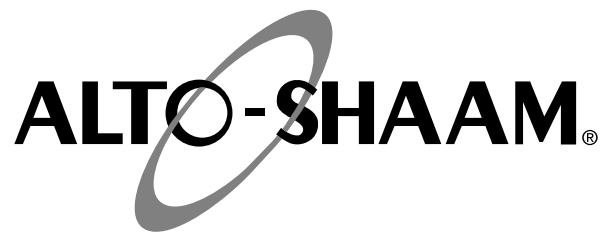

Delivery1
Unpacking1
Safety Procedures and Precautions2

Installation

Installation Requirements3
Clearance Requirements3
Dimension Drawings, Weights, Capacity 4-5
Options and Accessories6
Stacking7
Leveling8
Restraint Requirements - Mobile Equipment8
Drip Tray Installation9
Electrical Specifications 10-11

Operating Instructions

User Safety Information12
Start-Up Operation12
Cooking Oven Characteristics12
Simple Control Operation13
General Holding Guidelines14

Care and Cleaning

Cleaning and Preventative Maintenance15
Protecting Stainless Steel Surfaces16
Cleaning Agents16
Cleaning Materials16
Equipment Care16
Clean Daily16
Clean the Door Vents16
Check Overall Condition of Oven16

Sanitation

Sanitation/Food Safety17
Internal Food Product Temperatures17

Service

Trouble Shooting Checklist18
Exterior Service View - SINGLE COMPARTMENT ...19
Exterior Service Parts - SINGLE COMPARTMENT ...20
Exterior Service View - DOUBLE COMPARTMENT ...21
Exterior Service Parts - DOUBLE COMPARTMENT ...22
Electronic Components Service View and Parts .23
Cable Heating Kits24

Wire Diagrams

Always refer to the wire diagram(s) included with the unit for most current version.

Warranty

Transportation Damage and Claims... BACK COVER
Limited Warranty BACK COVER

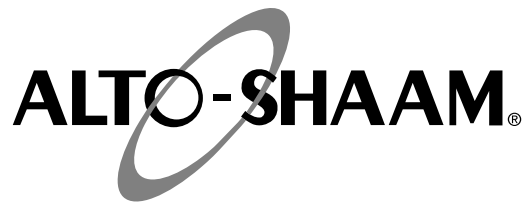

DELIVERY

This Alto-Shaam appliance has been thoroughly tested and inspected to ensure only the highest quality unit is provided. Upon receipt, check for any possible shipping damage and report it at once to the delivering carrier. *See Transportation Damage and Claims section located in this manual.*

This appliance, complete with unattached items and accessories, may have been delivered in one or more packages. Check to ensure that all standard items and options have been received with each model as ordered.

Save all the information and instructions packed with the appliance. Complete and return the warranty card to the factory as soon as possible to ensure prompt service in the event of a warranty parts and labor claim.

This manual must be read and understood by all people using or installing the equipment model. Contact the Alto-Shaam Tech Team Service Department if you have any questions concerning installation, operation, or maintenance.

NOTE: All claims for warranty must include the full model number and serial number of the unit.

UNPACKING

1. Carefully remove the appliance from the carton or crate.

NOTE: Do not discard the carton and other packaging material until you have inspected the unit for hidden damage and tested it for proper operation.

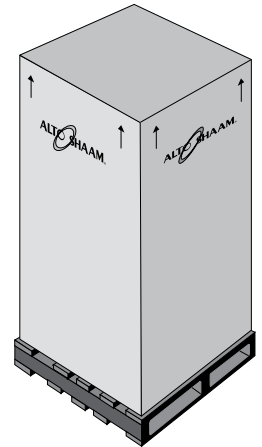

2. Read all instructions in this manual carefully before initiating the installation of this appliance.

DO NOT DISCARD THIS MANUAL.

This manual is considered to be part of the appliance and is to be provided to the owner or manager of the business or to the person responsible for training operators. *Additional manuals are available from the Alto-Shaam Tech Team Service Department.*

3. Remove all protective plastic film, packaging materials, and accessories from the appliance before connecting electrical power. Store any accessories in a convenient place for future use.

SAFETY PROCEDURES AND PRECAUTIONS

Knowledge of proper procedures is essential to the safe operation of electrically and/or gas energized equipment. In accordance with generally accepted product safety labeling guidelines for potential hazards, the following signal words and symbols may be used throughout this manual.

DANGER	
	Used to indicate the presence of a hazard that WILL cause severe personal injury, death, or substantial property damage if the warning included with this symbol is ignored.

WARNING	
	Used to indicate the presence of a hazard that CAN cause personal injury, possible death, or major property damage if the warning included with this symbol is ignored.

CAUTION	
	Used to indicate the presence of a hazard that can or will cause minor or moderate personal injury or property damage if the warning included with this symbol is ignored.

CAUTION	
Used to indicate the presence of a hazard that can or will cause minor personal injury, property damage, or a potential unsafe practice if the warning included with this symbol is ignored.	

NOTE: Used to notify personnel of installation, operation, or maintenance information that is important but not hazard related.
--

1. This appliance is intended to cook, hold or process foods for the purpose of human consumption. No other use for this appliance is authorized or recommended.
2. This appliance is intended for use in commercial establishments where all operators are familiar with the purpose, limitations, and associated hazards of this appliance. Operating instructions and warnings must be read and understood by all operators and users.
3. Any troubleshooting guides, component views, and parts lists included in this manual are for general reference only and are intended for use by qualified technical personnel.
4. This manual should be considered a permanent part of this appliance. This manual and all supplied instructions, diagrams, schematics, parts lists, notices, and labels must remain with the appliance if the item is sold or moved to another location.

NOTE	
	For equipment delivered for use in any location regulated by the following directive: DO NOT DISPOSE OF ELECTRICAL OR ELECTRONIC EQUIPMENT WITH OTHER MUNICIPAL WASTE.

INSTALLATION

DANGER



IMPROPER INSTALLATION, ALTERATION, ADJUSTMENT, SERVICE, OR MAINTENANCE COULD RESULT IN SEVERE INJURY, DEATH, OR CAUSE PROPERTY DAMAGE.

READ THE INSTALLATION, OPERATING AND MAINTENANCE INSTRUCTIONS THOROUGHLY BEFORE INSTALLING OR SERVICING THIS EQUIPMENT.

CAUTION



METAL PARTS OF THIS EQUIPMENT BECOME EXTREMELY HOT WHEN IN OPERATION. TO AVOID BURNS, ALWAYS USE HAND PROTECTION WHEN OPERATING THIS APPLIANCE.

CAUTION



TO PREVENT PERSONAL INJURY, USE CAUTION WHEN MOVING OR LEVELING THIS APPLIANCE.



DANGER



DO NOT store or use gasoline or other flammable vapors or liquids in the vicinity of this or any other appliance.

SITE INSTALLATION

The Alto-Shaam cook and hold oven must be installed in a location that will permit the oven to function for its intended purpose and to allow adequate clearance for ventilation, proper cleaning, and maintenance access.

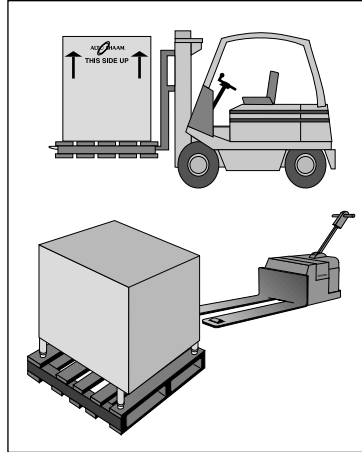

1. The oven must be installed on a stable and level surface.
2. **DO NOT** install this appliance in any area where it may be affected by any adverse conditions such as steam, grease, dripping water, high temperatures, or any other severely adverse conditions.
3. **DO NOT** store or use any flammable liquids or allow flammable vapors in the vicinity of this oven or any other appliance.
4. This appliance must be kept free and clear of any combustible materials.
5. This appliance must be kept free and clear of any obstructions blocking access for maintenance or service.

CLEARANCE REQUIREMENTS

BACK	3" (76mm)
TOP	2" (51mm)
EACH SIDE	1" (25mm)

INSTALLATION

SITE INSTALLATION

767-SK

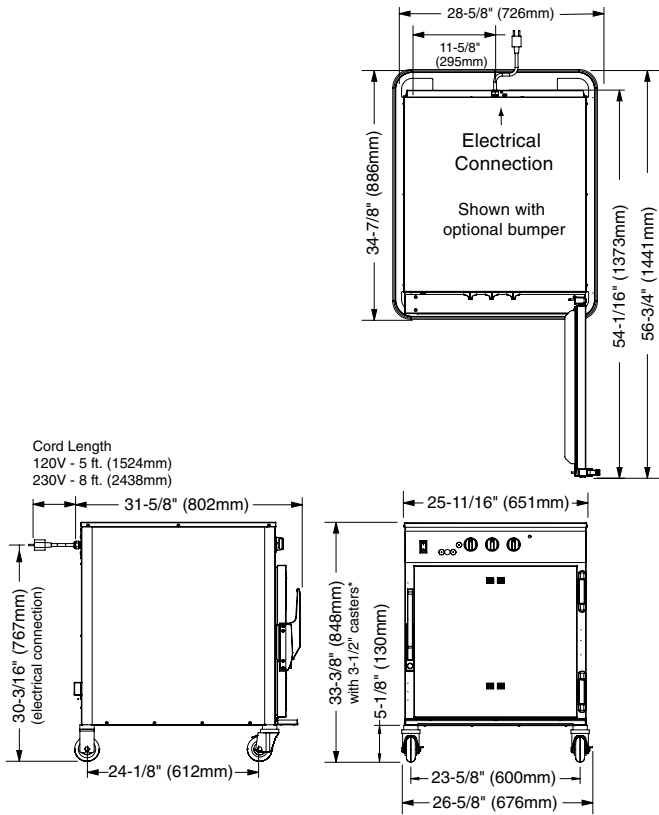

Cord Length
120V - 5 ft. (1524mm)
230V - 8 ft. (2438mm)

*31-11/16" (804mm) - with optional 2-1/2" casters
*35-1/16" (890mm) - with optional 5" casters
*33-13/16" (858mm) - with optional 6" legs

1767-SK

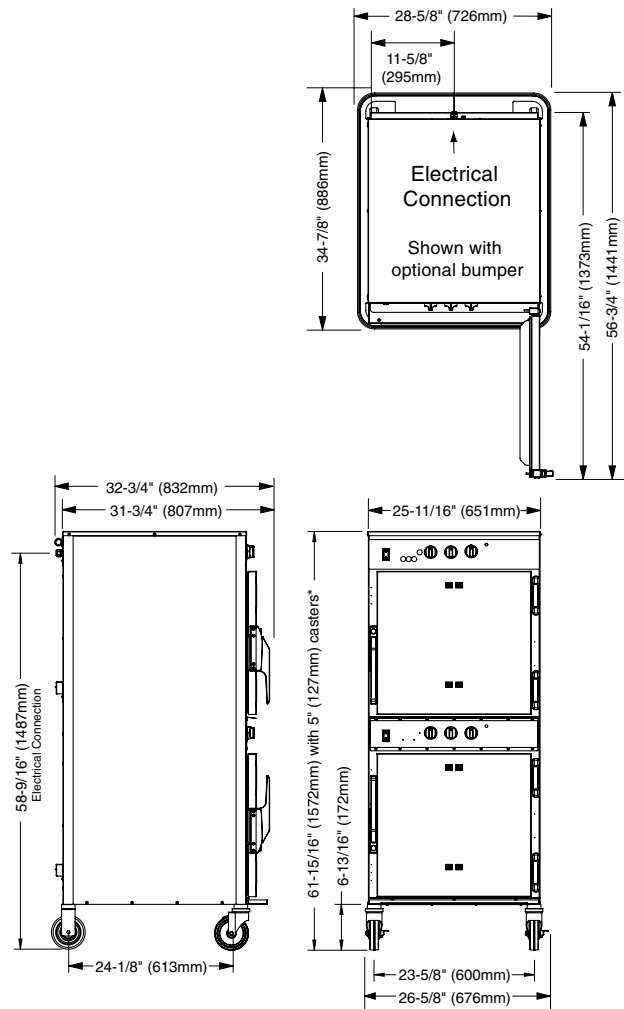

*60-11/16" (1540mm) - with optional 3-1/2" (89mm) casters
*62-1/8" (1577mm) - with optional 6" (152mm) legs

WEIGHT

MODEL	NET WEIGHT	SHIP WEIGHT
767-SK	197lb (89 kg)	225 lb (102 kg)
1767-SK	355 lb (161 kg) EST.	450 lb (204 kg)

CAPACITY PER COMPARTMENT

100 lb (45 kg) MAXIMUM
VOLUME MAXIMUM: 53 QUARTS (67 LITERS)

INSTALLATION

SITE INSTALLATION

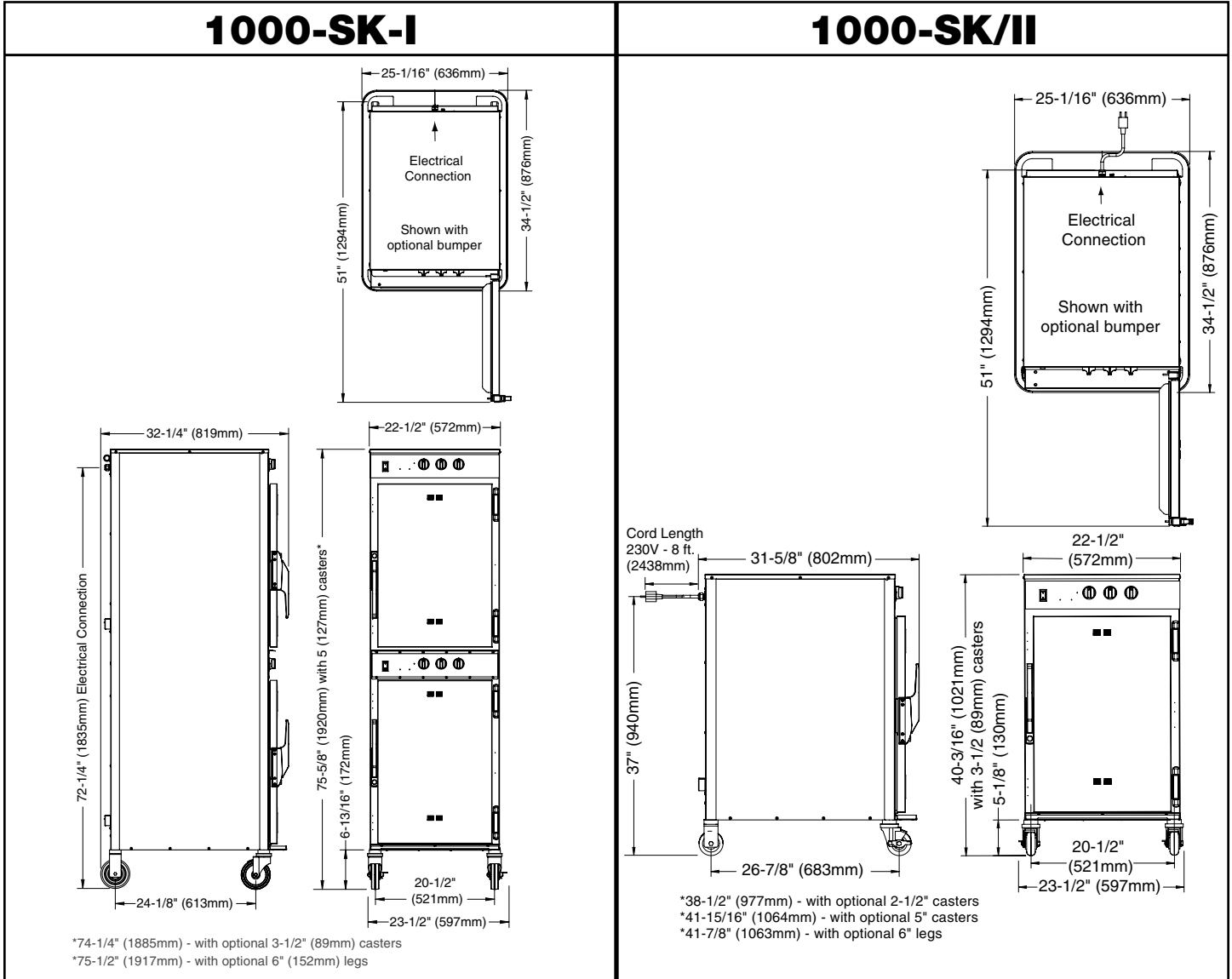

WEIGHT			CAPACITY PER COMPARTMENT	
MODEL	NET WEIGHT	SHIP WEIGHT		
1000-SK-I	377 lb (171 kg)	445 lb (202 kg) EST.	120 lb (54 kg) MAXIMUM VOLUME MAXIMUM: 60 QUARTS (76 LITERS)	
1000-SK/II	203 lb (92 kg) EST.	282 lb (101 kg) EST.		

INSTALLATION

SITE INSTALLATION

OPTIONS AND ACCESSORIES

MODEL >	767-SK	1767-SK	1000-SK-I	1000-SK/II
Bumper, Full Perimeter	5010371	5010371	5009767	5009767
Carving Holder PRIME RIB STEAMSHIP (CAFETERIA) ROUND	HL-2635 4459	HL-2635 4459	HL-2635 4459	HL-2635 4459
Casters - 2 RIGID, 2 SWIVEL W/BRAKE 5" (127mm) 3-1/2" (89mm) 2-1/2" (64mm)	5004862 STANDARD 5008022	STANDARD 5008017 ---	STANDARD 5008017 ---	5004862 STANDARD 5008022
Door Lock with Key	LK-22567	LK-22567	LK-22567	LK-22567
Drip Pan with Drain, 1-11/16" (43mm deep) Drip Pan without Drain 1-7/8" (62mm deep) Drip Pan without Drain 4" (101mm deep)	14831 --- ---	14831 --- ---	5005616 11906 15929	5005616 11906 15929
Legs, 6" (152mm), Stemmed (SET OF FOUR)	5011149	5011149	5011149	5011149
Pan Grid, Wire - 18" X 26" PAN INSERT	PN-2115	PN-2115	PN-2115	PN-2115
Security Panel with key lock	5004750	5004750	5011592	5005776
Shelf, Stainless Steel FLAT WIRE, REACH-IN RIB RACK	SH-2324 SH-2743	SH-2324 SH-2743	SH-2325 SH-29474	SH-2325 SH-29474
Stacking Hardware	5004864	---	---	5004864
Wood Chips, bulk pack Apple 20 lb (9 kg) Cherry 20 lb (9 kg) Hickory 20 lb (9 kg) Maple 20 lb (9 kg)	WC-22543 WC-22541 WC-2829 WC-22545	WC-22543 WC-22541 WC-2829 WC-22545	WC-22543 WC-22541 WC-2829 WC-22545	WC-22543 WC-22541 WC-2829 WC-22545

FACTORY INSTALLED OPTIONS

MODEL >	767-SK	1767-SK	1000-SK-I	1000-SK/II
Door SOLID WINDOW	STANDARD AVAILABLE	STANDARD AVAILABLE	STANDARD AVAILABLE	STANDARD AVAILABLE
Door Swing RIGHT HAND LEFT-HAND	STANDARD AVAILABLE	STANDARD AVAILABLE	STANDARD AVAILABLE	STANDARD AVAILABLE
Exterior Color Options STAINLESS STEEL BURGUNDY CUSTOM COLOR	STANDARD AVAILABLE AVAILABLE	STANDARD AVAILABLE AVAILABLE	STANDARD AVAILABLE AVAILABLE	STANDARD AVAILABLE AVAILABLE

INSTALLATION

SITE INSTALLATION

STACKING INSTRUCTIONS

- 1) If the two appliances were shipped together from the factory, the top unit will have the casters already removed. A stacking kit will be included with the shipment.

If casters need to be removed: lay the unit on its back, and remove the set screw on each caster. Pull the casters out of the unit.

- 2) While appliance is laid on its back, insert one stacking post in each of the four corners of the upper unit. Secure the stacking posts using one screw and two flat washers that come with the stacking kit.

Note: The flange on the stacking posts must face the outside of the unit.

- 3) Remove the four top mounting screws from the lower unit. Place the upper appliance, which has the stacking posts installed, on top of the bottom unit. Center the top unit from front to back. Re-install the four screws through the flange of the four stacking posts.

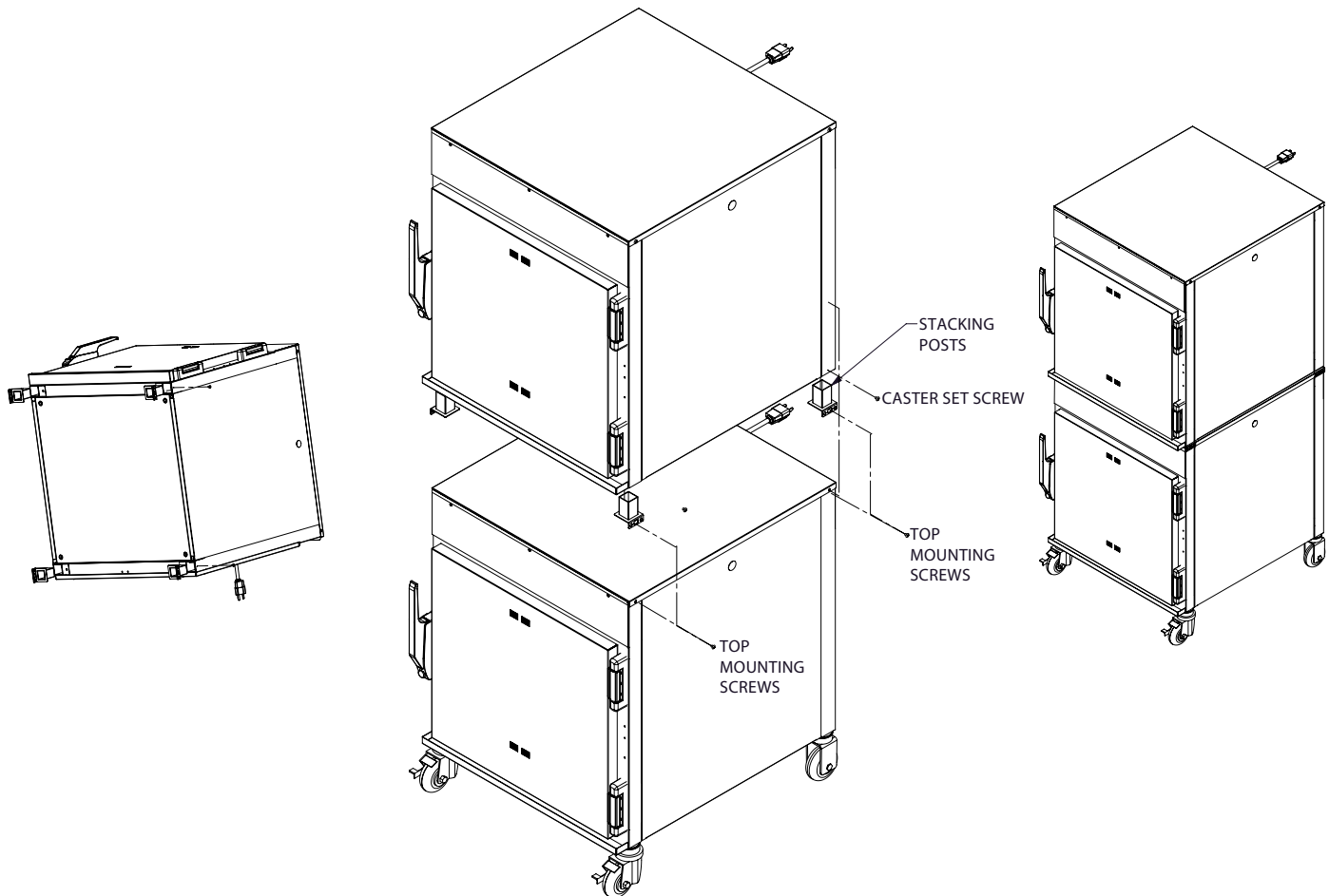

Stacking Configurations - 767-SK

767-SK with 767-SK, 750-TH/III,
750-TH-II, 767-SK/III, or 750-S

Stacking Configurations - 1000-SK/II

1000-SK/II with 1000-SK/II,
1000-TH/III, or 1000-S

INSTALLATION

SITE INSTALLATION

A number of adjustments are associated with initial installation and start-up. It is important that these adjustments be conducted by a qualified service technician. Installation and start-up adjustments are the responsibility of the dealer or user. These adjustments include but are not limited to thermostat calibration, door adjustment, leveling, electrical hook-up and installation of optional casters or legs.

LEVELING

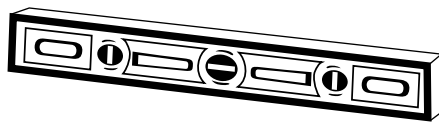

Level the oven from side-to-side and front-to-back with the use of a spirit level. For ovens installed with casters, it is important that the installation surface be level due to the probability of frequent oven repositioning.

We recommend checking the level of the oven periodically to make certain the floor has not shifted nor the oven moved.

NOTE: Failure to properly level this oven can cause improper function and will result in the uneven baking with products consisting of semi-liquid batter.

RESTRAINT REQUIREMENTS —MOBILE EQUIPMENT

 WARNING	
	RISK OF ELECTRIC SHOCK. Appliance must be secured to building structure.

Any appliance that is not furnished with a power supply cord but that includes a set of casters must be installed with a tether. Adequate means must be provided to limit the movement of this appliance without depending on or transmitting stress to the electrical conduit. The following requirements apply:

1. Casters must be a maximum height of 6" (152mm).
2. Two of the casters must be the locking type.
3. Such mobile appliances or appliances on mobile stands must be installed with the use of a flexible connector secured to the building structure.

A mounting connector for a restraining device is located on the upper back flange of the appliance. A flexible connector is not supplied by nor is it available from the factory.

INSTALLATION

SITE INSTALLATION

DRIP TRAY INSTALLATION INSTRUCTIONS

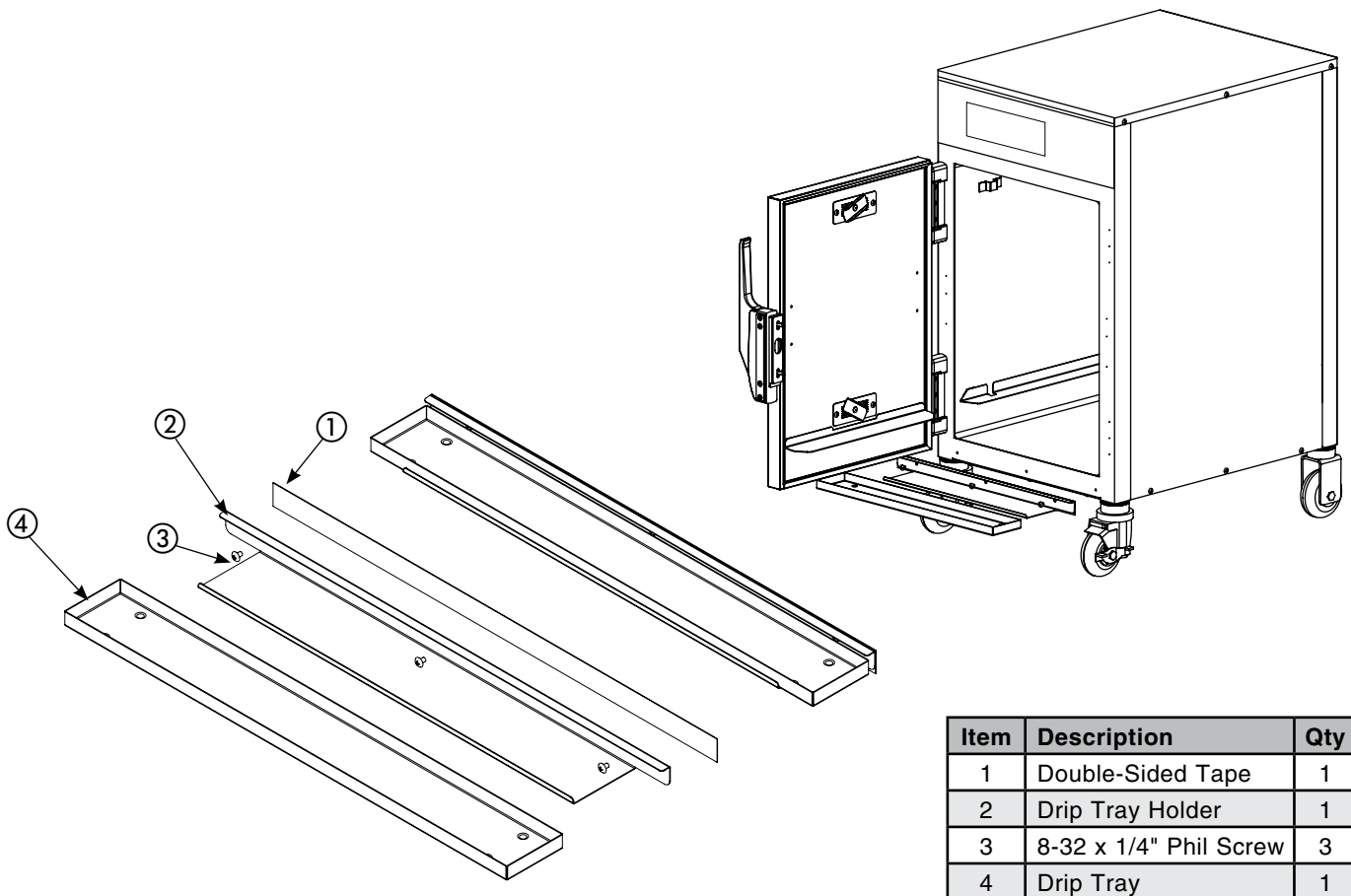

1. Poke holes through double-sided tape ① which is attached to the back of drip tray holder ②.
2. Remove backing on double-sided tape ①.
3. Put screws ③ through holes and attach drip tray holder ② to unit.
4. Optional, but strongly recommended - apply a line of food-grade silicone caulk along top edge of drip tray holder ② to seal.
5. Place drip tray ④ in drip tray holder ②.



WARNING



FAILURE TO PROPERLY INSTALL THE DRIP TRAY CAN OR WILL CAUSE MAJOR EQUIPMENT DAMAGE AND WILL RESULT IN A LEAKAGE HAZARD THAT CAN CAUSE PERSONAL INJURY.

INSTALLATION

ELECTRICAL CONNECTION

The appliance must be installed by a qualified service technician. The oven must be properly grounded in accordance with the National Electrical Code and applicable local codes.

Plug the unit into a properly grounded receptacle ONLY, positioning the unit so that the plug is easily accessible in case of an emergency. Arcing will occur when connecting or disconnecting the unit unless all controls are in the "OFF" position.

Proper receptacle or outlet configuration or permanent wiring for this unit must be installed by a licensed electrician in accordance with applicable local electrical codes.

REGARDING INTERNATIONAL STANDARD UNITS:

If the unit is not equipped with flexible cord and plug, an all-pole country approved disconnection device which has a contact separation of at least 3mm in all poles must be incorporated in the fixed wiring for disconnection. When using a cord without a plug, the green/yellow conductor shall be connected to the terminal which is marked with the ground symbol. If a plug is used, the socket outlet must be easily accessible. If the power cord needs replacement, use a similar one obtained from the distributor.

For CE approved units: To prevent an electrical shock hazard between the appliance and other appliances or metal parts in close vicinity, an equalization-bonding stud is provided. An equalization bonding lead must be connected to this stud and the other appliances / metal parts to provide sufficient protection against potential difference. The terminal is marked with the following symbol.



Hard wired models:

Hard wired models must be equipped with a country certified external allpole disconnection switch with sufficient contact separation.

If a power cord is used for the connection of the product an oil resistant cord like H05RN or H07RN or equivalent must be used.

NOTE: CE approved appliances must be connected to an electrical circuit that is protected by an external GFCI outlet.



DANGER	
	To avoid electrical shock, this appliance MUST be adequately grounded in accordance with local electrical codes or, in the absence of local codes, with the current edition of the National Electrical Code ANSI/NFPA No. 70. In Canada, all electrical connections are to be made in accordance with CSA C22.1, Canadian Electrical Code Part 1 or local codes.

DANGER	
	ENSURE POWER SOURCE MATCHES VOLTAGE STAMPED ON APPLIANCE NAMEPLATE.

DANGER	
	APPLIANCES WITH NO CORD PROVIDED BY FACTORY MUST BE EQUIPPED WITH A CORD OF SUFFICIENT LENGTH TO PERMIT THE APPLIANCE TO BE MOVED FOR CLEANING.
	ELECTRICAL CONNECTIONS MUST BE MADE BY A QUALIFIED SERVICE TECHNICIAN IN ACCORDANCE WITH APPLICABLE ELECTRICAL CODES.

INSTALLATION

ELECTRICAL CONNECTION

ELECTRICAL - 767-SK						
VOLTAGE	PHASE	CYCLE/HZ	AMPS	kW		CORD & PLUG
120	1	60	16.0	1.9		NEMA 5-20P 20A - 125V PLUG
208-240 (AGCY)	1	60	15.9	3.3		NO CORD
at 208	1	60	15.5	3.2		OR PLUG
at 240	1	60	12.3	2.9		
230	1	50/60	12.2	2.8		CEE 7/7 220-230V PLUG

ELECTRICAL - 1767-SK						
VOLTAGE	PHASE	CYCLE/HZ	AMPS	kW		CORD & PLUG
208-240 (AGCY)	1	60	30.8	6.4		NO CORD
at 208	1	60	31.0	6.5		OR PLUG
at 240	1	60	24.6	5.9		
230	1	50/60	24.3	5.6		NO CORD OR PLUG

ELECTRICAL - 1000-SK-I						
VOLTAGE	PHASE	CYCLE/HZ	AMPS	kW		CORD & PLUG
208-240 (AGCY)	1	60	31.4	6.5		NO CORD
at 208	1	60	30.7	6.4		OR PLUG
at 240	1	60	24.3	5.8		
230	1	50/60	24.1	5.5		NO CORD OR PLUG

ELECTRICAL - 1000-SK/II						
VOLTAGE	PHASE	CYCLE/HZ	AMPS	kW		CORD & PLUG
208-240 (AGCY)	1	60	15.7	3.3		NO CORD
at 208	1	60	15.3	3.2		OR PLUG
at 240	1	60	12.1	2.9		
230	1	50/60	12.2	2.8		CEE 7/7 220-230V PLUG

Wire diagrams are located inside the bonnet of the unit.

OPERATING INSTRUCTIONS

USER SAFETY INFORMATION

CAUTION



METAL PARTS OF THIS EQUIPMENT BECOME EXTREMELY HOT WHEN IN OPERATION. TO AVOID BURNS, ALWAYS USE HAND PROTECTION WHEN OPERATING THIS APPLIANCE.

The Alto-Shaam cook and hold oven is intended for use in commercial establishments by qualified operating personnel where all operators are familiar with the purpose, limitations, and associated hazards of this appliance. Operating instructions and warnings must be read and understood by all operators and users.

START-UP OPERATION

BEFORE INITIAL USE:

Interior oven surfaces must be heated to remove surface oils and the accompanying odor produced during the first use of the oven.

1. Wipe all wire shelves, side racks and the full oven interior with a clean, damp cloth. Install the oven side racks, oven shelves, wood chip tray, and external drip tray. Shelves are installed with the curved edge toward the back of the oven. Insert the drip pan on the interior bottom surface of the oven.
2. Close the oven doors, press the power switch to the ON position, and set the thermostat to 300°F (149°C).
3. Allow the oven to cycle for approximately 2 hours or until no odor is detected.

PREHEATING:

Always preheat the oven for a minimum of 20 minutes before cooking product. Follow the operating instructions indicated on the next page of this manual.

DANGER



AT NO TIME SHOULD THE INTERIOR OR EXTERIOR BE STEAM CLEANED, HOSED DOWN, OR FLOODED WITH WATER OR LIQUID SOLUTION OF ANY KIND. DO NOT USE WATER JET TO CLEAN.



SEVERE DAMAGE OR ELECTRICAL HAZARD COULD RESULT.

WARRANTY BECOMES VOID IF APPLIANCE IS FLOODED



DANGER



DISCONNECT UNIT FROM POWER SOURCE BEFORE CLEANING OR SERVICING.

COOKING OVEN CHARACTERISTICS:

The oven is equipped with a special, high heat density, heating cable. Through the Halo Heat concept, the heating cable is mounted against the walls of the cooking cavity to provide an evenly applied, thermostatically controlled, heat source. The design and operational characteristics of the oven eliminate the need for a moisture pan or a heat circulating fan. Through even heat application, the quality of a food product is maintained for many hours.

OPERATING INSTRUCTIONS

1. Push power switch to ON (I) position.

Control will display 0°F or 0°C.

2. Set the holding temperature.

- Rotate the hold knob to the desired holding temperature. The set temperature will appear in the Digital Display **140F** and the temperature display button will illuminate.
- The holding indicator light will illuminate while in hold mode.
- Holding temperature range:
60° to 205°F (16 to 96°C)

3. Set the cooking temperature.

- Rotate the cook knob to the desired temperature. The set temperature will appear in the Digital Display **250F** and the temperature display button will illuminate.
- The cooking indicator light will illuminate while in cook mode.
- Cooking temperature range:
200° to 325°F (94 to 160°C)
- **Note:** Cooking mode not active unless timer is running.

4. Set timer.

- Press Up or Down arrows when cook knob is set to begin cooking.
- Press Up or Down arrows to adjust the time while cooking.
- **Note:** Hold timer button for 3 seconds when in cook mode to *cancel* timer (display shows **----**).

5. PREHEAT oven for 30 minutes before loading food. The heat indicator light will illuminate and will remain lit as long as the oven is calling for heat.

6. Load the oven with food and adjust cooking timer as needed.

5. Load wood chip container.

Take one container load of dry wood chips and soak the chips in water for 15 to 20 minutes. Shake excess water off wood chips. Remove wood chip container from the interior back panel of the smoker. Place the moistened chips in the wood chip container and replace the container in the oven.

6. Set the Smoke Timer.

The Smoke Timer activates the heating element located within the wood chip container. When the wood chip container is full and the smoking timer is turned clockwise as far as it will turn, the wood chips will smoke for approximately forty-five minutes to one hour.

- To set the Smoke Timer, turn the smoking timer knob past the required length of time, then immediately bring it back to the correct setting.
- Smoke Indicator Light will illuminate.
- Keep the oven door completely closed during the smoking cycle.

Notes:

- When the oven temperature reaches the set temperature, the heat indicator light will turn off.
- Press and hold the Temperature Display Button for 3 seconds at any time to display the *Actual* oven temperature **190F**.

To toggle between fahrenheit (°F) and celsius (°C):

Press the **Temperature Display Button** at any time to display the alternate temperature.

The factory default is Fahrenheit. To change to Celsius:

1. Press and hold the **Temperature Display Button** and the **Down Arrow Key** for 5 seconds.
2. The control will show **℃** for 3 seconds to verify selection and then show the temperature in °C.
3. Repeat to toggle to Fahrenheit.

Note: With a power failure, factory test, etc., the control will retain the °C or °F setting selected by the user when power is restored.

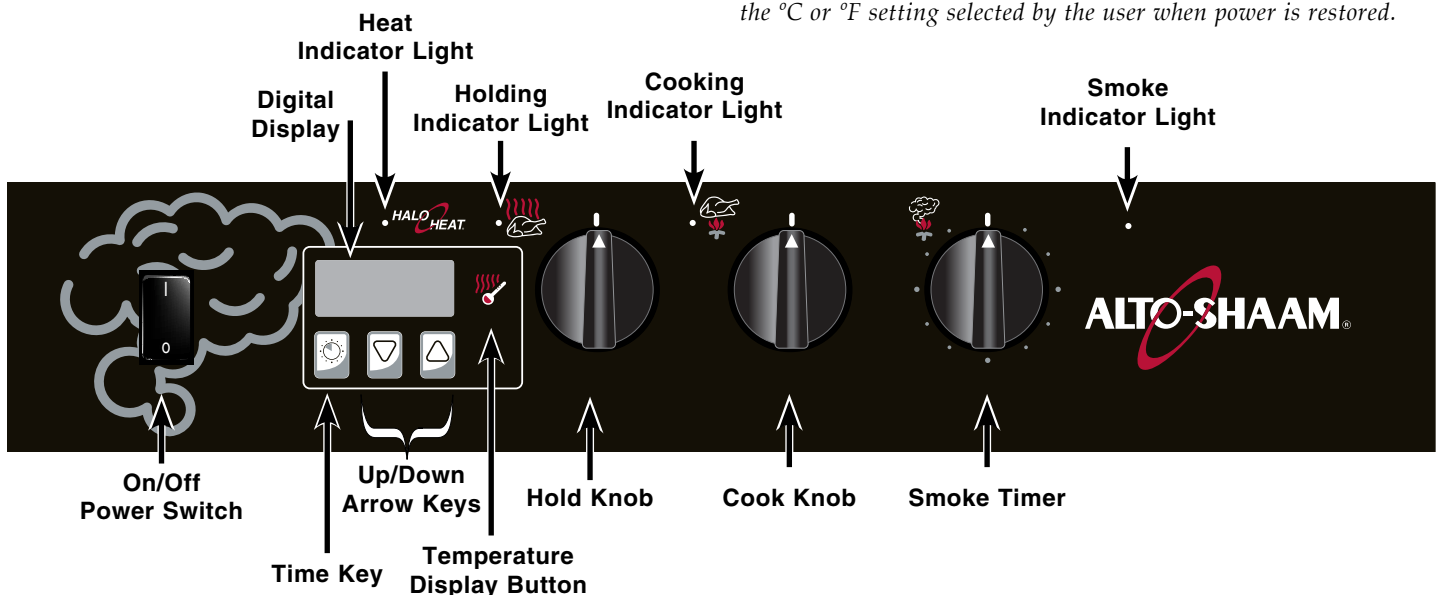

OPERATING INSTRUCTIONS

General Holding Guideline

Chefs, cooks and other specialized food service personnel employ varied methods of cooking. Proper holding temperatures for a specific food product must be based on the moisture content of the product, product density, volume, and proper serving temperatures. Safe holding temperatures must also be correlated with palatability in determining the length of holding time for a specific product.

Halo Heat maintains the maximum amount of product moisture content without the addition of water, water vapor, or steam. Maintaining maximum natural product moisture preserves the natural flavor of the product and provides a more genuine taste. In addition to product moisture retention, the gentle properties of Halo Heat maintain a consistent temperature throughout the cabinet without the necessity of a heat distribution fan, thereby preventing further moisture loss due to evaporation or dehydration.

When product is removed from a high temperature cooking environment for immediate transfer into equipment with the lower temperature required for hot food holding, condensation can form on the outside of the product and on the inside of plastic containers used in self-service applications. Allowing the product to release the initial steam and heat produced by high temperature cooking can alleviate this condition. To preserve the safety and quality of freshly cooked foods, however, a maximum of 1 to 2 minutes must be the only time period allowed for the initial heat to be released from the product.

Most Halo Heat holding equipment is provided with a thermostat control between 60° and 200°F (16° to 93°C). If the unit is equipped with vents, close the vents for moist holding and open the vents for crisp holding.

HOLDING TEMPERATURE RANGE		
MEAT	FAHRENHEIT	CELSIUS
BEEF ROAST — Rare	130°F	54°C
BEEF ROAST — Med/Well Done	155°F	68°C
BEEF BRISKET	160° — 175°F	71° — 79°C
CORN BEEF	160° — 175°F	71° — 79°C
PASTRAMI	160° — 175°F	71° — 79°C
PRIME RIB — Rare	130°F	54°C
STEAKS — Broiled/Fried	140° — 160°F	60° — 71°C
RIBS — Beef or Pork	160°F	71°C
VEAL	160° — 175°F	71° — 79°C
HAM	160° — 175°F	71° — 79°C
PORK	160° — 175°F	71° — 79°C
LAMB	160° — 175°F	71° — 79°C
POULTRY		
CHICKEN — Fried/Baked	160° — 175°F	71° — 79°C
DUCK	160° — 175°F	71° — 79°C
TURKEY	160° — 175°F	71° — 79°C
GENERAL	160° — 175°F	71° — 79°C
FISH/SEAFOOD		
FISH — Baked/Fried	160° — 175°F	71° — 79°C
LOBSTER	160° — 175°F	71° — 79°C
SHRIMP — Fried	160° — 175°F	71° — 79°C
BAKED GOODS		
BREADS/ROLLS	120° — 140°F	49° — 60°C
MISCELLANEOUS		
CASSEROLES	160° — 175°F	71° — 79°C
DOUGH — Proofing	80° — 100°F	27° — 38°C
EGGS — Fried	150° — 160°F	66° — 71°C
FROZEN ENTREES	160° — 175°F	71° — 79°C
HORS D'OEUVRES	160° — 180°F	71° — 82°C
PASTA	160° — 180°F	71° — 82°C
PIZZA	160° — 180°F	71° — 82°C
POTATOES	180°F	82°C
PLATED MEALS	140° — 165°F	60° — 74°C
SAUCES	140° — 200°F	60° — 93°C
SOUP	140° — 200°F	60° — 93°C
VEGETABLES	160° — 175°F	71° — 79°C
THE HOLDING TEMPERATURES LISTED ARE SUGGESTED GUIDELINES ONLY. ALL FOOD HOLDING SHOULD BE BASED ON INTERNAL PRODUCT TEMPERATURES. ALWAYS FOLLOW LOCAL HEALTH (HYGIENE) REGULATIONS FOR ALL INTERNAL TEMPERATURE REQUIREMENTS.		

CARE AND CLEANING

CLEANING AND PREVENTIVE MAINTENANCE

PROTECTING STAINLESS STEEL SURFACES



It is important to guard against corrosion in the care of stainless steel surfaces. Harsh, corrosive, or inappropriate chemicals can completely destroy the protective surface layer of stainless steel. Abrasive

pads, steel wool, or metal implements will abrade surfaces causing damage to this protective coating and will eventually result in areas of corrosion. Even water, particularly hard water that contains high to moderate concentrations of chloride, will cause oxidation and pitting that result in rust and corrosion. In addition, many acidic foods spilled and left to remain on metal surfaces are contributing factors that will corrode surfaces.

Proper cleaning agents, materials, and methods are vital to maintaining the appearance and life of this appliance. Spilled foods should be removed and the area wiped as soon as possible but at the very least, a minimum of once a day. Always thoroughly rinse surfaces after using a cleaning agent and wipe standing water as quickly as possible after rinsing.

CLEANING AGENTS

Use non-abrasive cleaning products designed for use on stainless steel surfaces. Cleaning agents must be chloride-free compounds and must not contain quaternary salts. Never use hydrochloric acid (muriatic acid) on stainless steel surfaces. Always use the proper cleaning agent at the manufacturer's recommended strength. Contact your local cleaning supplier for product recommendations.

CLEANING MATERIALS

The cleaning function can usually be accomplished with the proper cleaning agent and a soft, clean cloth. When more aggressive methods must be employed, use a non-abrasive scouring pad on difficult areas and make certain to scrub with the visible grain of surface metal to avoid surface scratches. Never use wire brushes, metal scouring pads, or scrapers to remove food residue.

 CAUTION	
	TO PROTECT STAINLESS STEEL SURFACES, COMPLETELY AVOID THE USE OF ABRASIVE CLEANING COMPOUNDS, CHLORIDE BASED CLEANERS, OR CLEANERS CONTAINING QUATERNARY SALTS. NEVER USE HYDROCHLORIC ACID (MURIATIC ACID) ON STAINLESS STEEL. NEVER USE WIRE BRUSHES, METAL SCOURING PADS OR SCRAPERS.
	
	

CARE AND CLEANING

EQUIPMENT CARE

Under normal circumstances, this oven should provide you with long and trouble free service. There is no preventative maintenance required, however, the following Equipment Care Guide will maximize the potential life and trouble free operation of this oven.

The cleanliness and appearance of this equipment will contribute considerably to operating efficiency and savory, appetizing food. Good equipment that is kept clean works better and lasts longer.



CLEAN DAILY

1. Disconnect unit from power source and let cool.
2. Remove all detachable items such as wire shelves, side racks, and drip pans. Clean these items separately.
3. Wipe the interior metal surfaces of the oven with a paper towel to remove loose food debris.
4. Clean the interior metal surfaces of the cabinet with a damp clean cloth or sponge and any good commercial detergent.



NOTE: Avoid the use of abrasive cleaning compounds, chloride based cleaners, or cleaners containing quaternary salts. Never use hydrochloric acid (muriatic acid) on stainless steel.

5. Spray heavily soiled areas with a water soluble degreaser and let stand for 10 minutes, then remove soil with a plastic scouring pad.
6. Wipe control panel, door vents, door handles, and door gaskets thoroughly since these areas harbor food debris.
7. Rinse surfaces by wiping with sponge and clean, warm water.

	DANGER
	ENSURE POWER SOURCE MATCHES VOLTAGE STAMPED ON APPLIANCE NAMEPLATE.

8. Remove excess water with sponge and wipe dry with a clean cloth or air dry. Leave doors open until interior is completely dry. Replace side racks and shelves.
9. Wipe door gaskets and control panel dry with a clean, soft cloth.
10. Interior can be wiped with a sanitizing solution after cleaning and rinsing. This solution must be approved for use on stainless steel food contact surfaces.
11. To help maintain the protective film coating on polished stainless steel, clean the exterior of the cabinet with a cleaner recommended for stainless steel surfaces. Spray the cleaning agent on a clean cloth and wipe with the grain of the stainless steel.
12. Clean any glass with a window cleaner.

Always follow appropriate state or local health (hygiene) regulations regarding all applicable cleaning and sanitation requirements for equipment.

CLEAN THE DOOR VENTS

Door vents need to be inspected and cleaned as required.

CHECK OVERALL CONDITION OF OVEN ONCE A MONTH

Check the oven once a month for physical damage and loose screws. Correct any problems before they begin to interfere with the operation of the oven.

DANGER	
	AT NO TIME SHOULD THE INTERIOR OR EXTERIOR BE STEAM CLEANED, HOSED DOWN, OR FLOODED WITH WATER OR LIQUID SOLUTION OF ANY KIND. DO NOT USE WATER JET TO CLEAN.
	SEVERE DAMAGE OR ELECTRICAL HAZARD COULD RESULT.
	WARRANTY BECOMES VOID IF APPLIANCE IS FLOODED

DO NOT USE OVEN IF CONTROLS ARE NOT PROPERLY FUNCTIONING

Refer to the Trouble Shooting Guide located in this manual or call an authorized service technician.

SANITATION

Food flavor and aroma are usually so closely related that it is difficult, if not impossible, to separate them. There is also an important, inseparable relationship between cleanliness and food flavor. Cleanliness, top operating efficiency, and appearance of equipment contribute considerably to savory, appetizing foods. Good equipment that is kept clean, works better and lasts longer.

Most food imparts its own particular aroma and many foods also absorb existing odors. Unfortunately, during this absorption there is not distinction between GOOD and BAD odors. The majority of objectionable flavors and odors troubling food service operations are caused by bacteria growth. Sourness, rancidity, mustiness, stale or other OFF flavors are usually the result of germ activity.

The easiest way to insure full, natural food flavor is through comprehensive cleanliness. This means good control of both visible soil (dirt) and invisible soil (germs). A thorough approach to sanitation will provide essential cleanliness. It will assure an attractive appearance of equipment, along with maximum efficiency and utility. More importantly, a good sanitation program provides one of the key elements in the prevention of food-borne illnesses.

A controlled holding environment for prepared foods is just one of the important factors involved in the prevention of food-borne illnesses. Temperature monitoring and control during receiving, storage, preparation, and the service of foods are of equal importance.

The most accurate method of measuring safe temperatures of both hot and cold foods is by internal product temperature. A quality thermometer is an effective tool for this purpose, and should be routinely used on all products that require holding at a specific temperature.

A comprehensive sanitation program should focus on the training of staff in basic sanitation procedures. This includes personal hygiene, proper handling of raw foods, cooking to a safe internal product temperature, and the routine monitoring of internal temperatures from receiving through service.

Most food-borne illnesses can be prevented through proper temperature control and a comprehensive program of sanitation. Both these factors are important to build quality service as the foundation of customer satisfaction. Safe food handling practices to prevent food-borne illness is of critical importance to the health and safety of your customers.

HACCP, an acronym for Hazard Analysis (at) Critical Control Points, is a quality control program of operating procedures to assure food integrity, quality, and safety. Taking steps necessary to augment food safety practices is both cost effective and relatively simple. While HACCP guidelines go far beyond the scope of this manual, additional information is available by contacting:

**CENTER FOR FOOD SAFETY AND APPLIED
NUTRITION FOOD AND DRUG ADMINISTRATION
1-888-SAFEFOOD**

INTERNAL FOOD PRODUCT TEMPERATURES		
HOT FOODS		
DANGER ZONE	40° TO 140°F	(4° TO 60°C)
CRITICAL ZONE	70° TO 120°F	(21° TO 49°C)
SAFE ZONE	140° TO 165°F	(60° TO 74°C)
COLD FOODS		
DANGER ZONE	ABOVE 40°F	(ABOVE 4°C)
SAFE ZONE	36° TO 40°F	(2° TO 4°C)
FROZEN FOODS		
DANGER ZONE	ABOVE 32°F	(ABOVE 0°C)
CRITICAL ZONE	0° TO 32°F	(-18° TO 0°C)
SAFE ZONE	0°F or below	(-18°C or below)

SERVICE

TROUBLE SHOOTING CHECKLIST

Error Code	Description	Possible Cause
E-10	Cavity air sensor shorted	Cavity air sensor reading < 5°F. Verify sensor integrity. See sensor test instructions below.
E-11	Cavity air sensor open	Cavity air sensor reading > 517°F. Verify sensor integrity. See sensor test instructions below.
E-20	Product probe is shorted <i>Oven will cook in time only</i>	Product probe reading < 5°F. Verify sensor integrity. See sensor test instructions below.
E-21	Product probe is open <i>Oven will cook in time only</i>	Product Probe reading > 517°F. Verify sensor integrity. See sensor test instructions below.
E-30	Under temperature	Unit has not reached set-point for more than 90 minutes.
E-31	Over temperature	Unit has been higher than 25°F above the maximum cavity set-point for more than 2 minutes. Note: Holding Cabinets with this error code are more than 145°F higher than the maximum set-point.
E-50	Temp. measurement error	Contact factory.
E-51	Temp. measurement error	Contact factory.
E-60	Real time clock error	Data set to factory default. Ensure that date and time are correct if applicable.
E-61	Real time clock error	Contact factory.
E-70	Configuration connector error (DIP switch)	Refer to wiring diagram for the particular model and ensure dip switches on the control match the settings called out on the WD. If the dip switch settings are correct according to the print replace the control.
E-78	Voltage low	Voltage below 90 VAC on a 125 VAC unit, or below 190 VAC on a 208-240 VAC unit. Correct voltage.
E-79	Voltage high	Voltage over 135 VAC on a 125 VAC unit, or over 250 VAC on a 208-240 VAC unit. Correct voltage.
E-80	EEPROM Error	Ensure that all temperatures and times are properly set. Contact factory if problem persists.
E-81	EEPROM Error	Contact factory.
E-82	EEPROM Error	Contact factory.
E-83	EEPROM Error	Contact factory.
E-85	EEPROM Error	All timers, if previously on, are now off. Possible bad EEPROM.
E-86	EEPROM Error	Stored HACCP memory corrupted. HACCP Address reset to 1. Possible bad EEPROM. Contact factory if problem persists.
E-87	EEPROM Error	Stored offsets corrupted. Offsets reset to 0. Control may need a recalibration. Possible bad EEPROM. Contact factory if problem persists.
E-88	EEPROM Error	All timer set-points are reset to 1 minute. Timers, if previously on, are now off. Possible bad EEPROM.
E-90	Button stuck	A button has been held down for >60 seconds. Adjust control. Error will reset when the problem has been resolved.
E-dS	Datakey error	Datakey digital signature incompatible. Cycle power, and install compatible Datakey if error persists.
E-dT	Datakey error	Datakey incompatible with control. Install compatible Datakey.
E-du	Datakey unplugged	Install Datakey and cycle power to control to clear error.

Note: If in doubt, always cycle the power to the control and contact factory if the problem persists.

To test probe and air sensor:

Test probe and air sensor by placing sensor in ice water bath and using an ohmmeter set on the ohm scale. The reading should be 100 ohms resistance. If it is more than 2 ohms higher or lower, sensor needs to be replaced.

SERVICE

SERVICE VIEW - SINGLE COMPARTMENT (1000-SK/II Shown) **A**

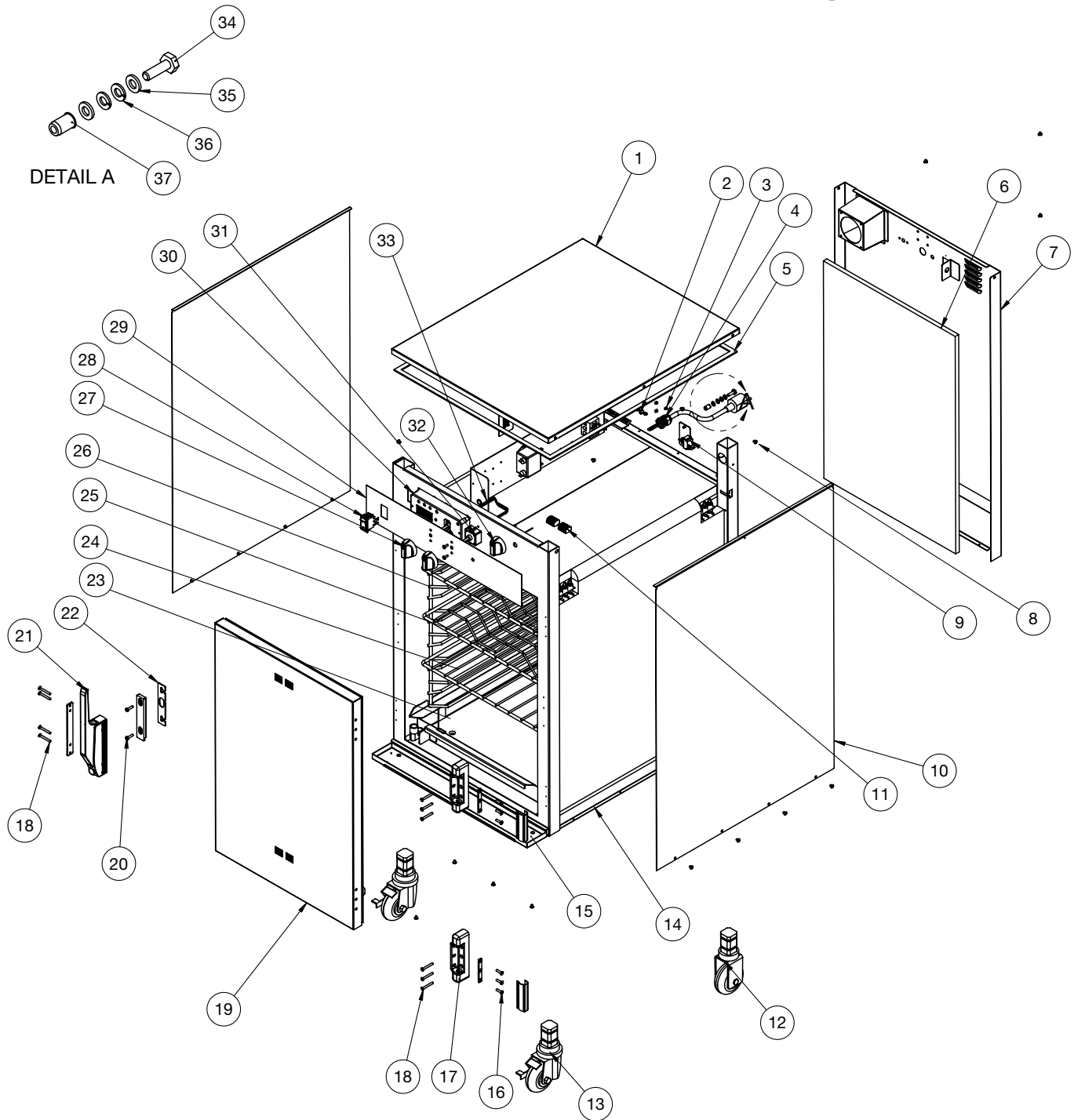

Part numbers and drawings are subject to change without notice.

⚠ DANGER

LOCK-OUT OR POST BREAKER PANEL UNTIL SERVICE WORK HAS BEEN COMPLETED.

⚠ DANGER

DISCONNECT UNIT FROM POWER SOURCE BEFORE CLEANING OR SERVICING.

SERVICE PARTS LIST - SINGLE COMPARTMENT



		MODEL >	767-SK		1000-SK/II	
ITEM	DESCRIPTION	PART NO.	QTY	PART NO.	QTY	
1	TOP COVER	1011872	1	1011534	1	
2	PLUG, HOLE 3/8"	PG-25574	1	PG-25574	1	
3	PLUG, DOME, 187" HOLE	PG-28439	6	PG-28439	6	
4	BUSHING, STRAIGHT, STRAIN RELIEF	BU-3964	1	BU-3964	1	
5	GASKETS, ADHESIVE, .125X.375 [linear ft]	GS-23622	1	GS-23622	1	
6	INSULATION	IN-2003	1	IN-2003	1	
7	REAR TRIM, SPOT	5014137	1	5014204	1	
8	RIVET, BLIND, #44, STNLS	RI-2100	6	RI-2100	6	
9	SWITCH COVER	11133	1	11133	1	
10	SIDE PANEL	1011871	2	1011619	2	
11	CONNECTOR-5 CONDUCTOR	CR-34646	2	CR-34646	2	
12	CASTER, 1.5" STEM, RIGID 5"	CS-24874	2	CS-24874	2	
13	CASTER, 1.5" STEM, 5" SWIVEL WITH BRAKE	CS-24875	2	CS-24875	2	
14	BOTTOM PANEL	1010394	1	1009941	1	
15	DRIP TRAY KIT	5010391	1	5009716	1	
	- DRIP TRAY	1010584	1	1010189	1	
	- DRIP TRAY BRACKET	1010585	1	1010188	1	
16	SCREW, 10-32 X 3/4", NF PHIL, FLAT M/S, 18-8 S/S	SC-2072	6	SC-2072	6	
17	HINGE, 1-3/8" OFFSET, PAIR, CHROME	HG-22338	2	HG-22338	2	
18	SCREW, 10-32 X 1-1/2", NF, PHIL, FLAT M/S, 18-8 S/S	SC-2073	10	SC-2073	6	
19	DOOR ASSEMBLY, RH	5011828	1	5013154	1	
	DOOR ASSEMBLY, LH	5011829	1	5013155	1	
	DOOR GASKET	GS-22951	1	GS-22952	1	
20	SCREW, 10-32 X 3/4" PHILLIPS PAN HD	SC-2071	2	SC-2071	2	
21	HANDLE, OFFSET MAGNETIC LATCH	HD-27080	1	HD-27080	1	
22	SHIM, HANDLE	13947	1	13947	1	
23	DRIP PAN WELD	14831	1	5005616	1	
24	SHELF, WIRE S/S	SH-2324	2	SH-2325	2	
25	SHELF, RIB RACK	SH-2743	2	SH-29474	1	
26	SIDE RACKS	SR-28405	2	SR-2266	2	
	PAN SLIDES	1010813	2	—	—	
27	KNOB	KN-26568	3	KN-26568	3	
28	SWITCH, ROCKER, 20A	SW-34769	1	SW-34769	1	
29	PANEL OVERLAY	PE-29361	1	PE-29383	1	
30	CONTROL	CC-34488	1	CC-34488	1	
31	THERMOSTAT, COOK	TT-34910	1	TT-34910	1	
32	TIMER, 1 HR, 208-240V	TR-34539	1	TR-34539	1	
	TIMER, 1 HR, 120V	TR-34540	1	TR-34540	1	
33	CABLE HARNESS	CB-34945	1	CB-34945	1	
34	SCREW, HHCS, M6 X 20	SC-22924	1	SC-22924	1	
35	WASHER, FLAT, M6, DIN 125	WS-22297	2	WS-22297	2	
36	WASHER, M6 SPLIT LOCK S/S 18-8	WS-22302	2	WS-22302	2	
37	NUT, THREADED INSERT, M6	NU-22770	1	NU-22770	1	
38*	ELEMENT COVER, SMOKE	1010409	1	1011813	1	
39*	CHIP TRAY WELD	4652R	1	4652R	1	
40*	BRACKET, PILOT LIGHT	1004360	1	1004360	1	
41*	NON-PRODUCT PROBE SEAL	1006871	1	1006871	1	
42*	BRACKET, SENSOR MOUNTING	1008272	1	1008272	1	
43*	BACK CASING	1010393	1	1011878	1	
44*	SMOKE HEATER PLATE WELD	5003782	1	5003782	1	
45*	BLOCK, SENSOR	BK-27878	1	BK-27878	1	
46*	BLOCK, TERMINAL, PORCELAIN	BK-33546	1	BK-33546	1	
47*	BRACKET, CHIP TRAY	BT-29217	1	BT-29217	1	
48*	BUSHING, BLACK, 5/8" SNAP	BU-3611	2	BU-3611	2	
49*	CONNECTOR	CR-34559	2	CR-34559	2	
50*	FAN, BOX, 120V	FA-3973	1	FA-3973	1	
	FAN BOX, 208-240V, 230V	FA-34524	1	FA-34524	1	
51*	PILOT LIGHT, 208-240V	LI-3951	1	LI-3951	1	
	PILOT LIGHT, 120V	LI-3027	1	LI-3027	1	
52*	NUT, HEX M4-0.7 18-8	NU-22286	2	NU-22286	2	
53*	NUT, HEX #8-32	NU-2296	2	NU-2296	2	
54*	NUT, 1/4-20 HEX S/S	NU-2437	2	NU-2437	2	
55*	SENSOR, OVEN TEMPERATURE	PR-34494	1	PR-34494	1	
56*	SCREW, 6-32 X 1/2", NC PHIL, FLAT	SC-2239	2	SC-2239	2	
57*	SCREW, 8-32 X 2" SLOT PAN HEAD 18-8 S/S	SC-23154	2	SC-23154	2	
58*	SCREW, 8-32 X 1/2" PHIL SCREW	SC-2425	2	SC-2425	2	
59*	SCREW, 8-32 x 1/4" PHIL	SC-2459	33	SC-2459	29	
60*	SWITCH, TOGGLE, VOLTAGE	SW-3528	1	SW-3528	1	
61*	WASHER, M4 SPLIT LOCK S/S 18-8	WS-22300	2	WS-22300	2	

*NOT SHOWN

SERVICE

EXTERIOR VIEW - DOUBLE COMPARTMENT (1000-SK-I Shown) **B**

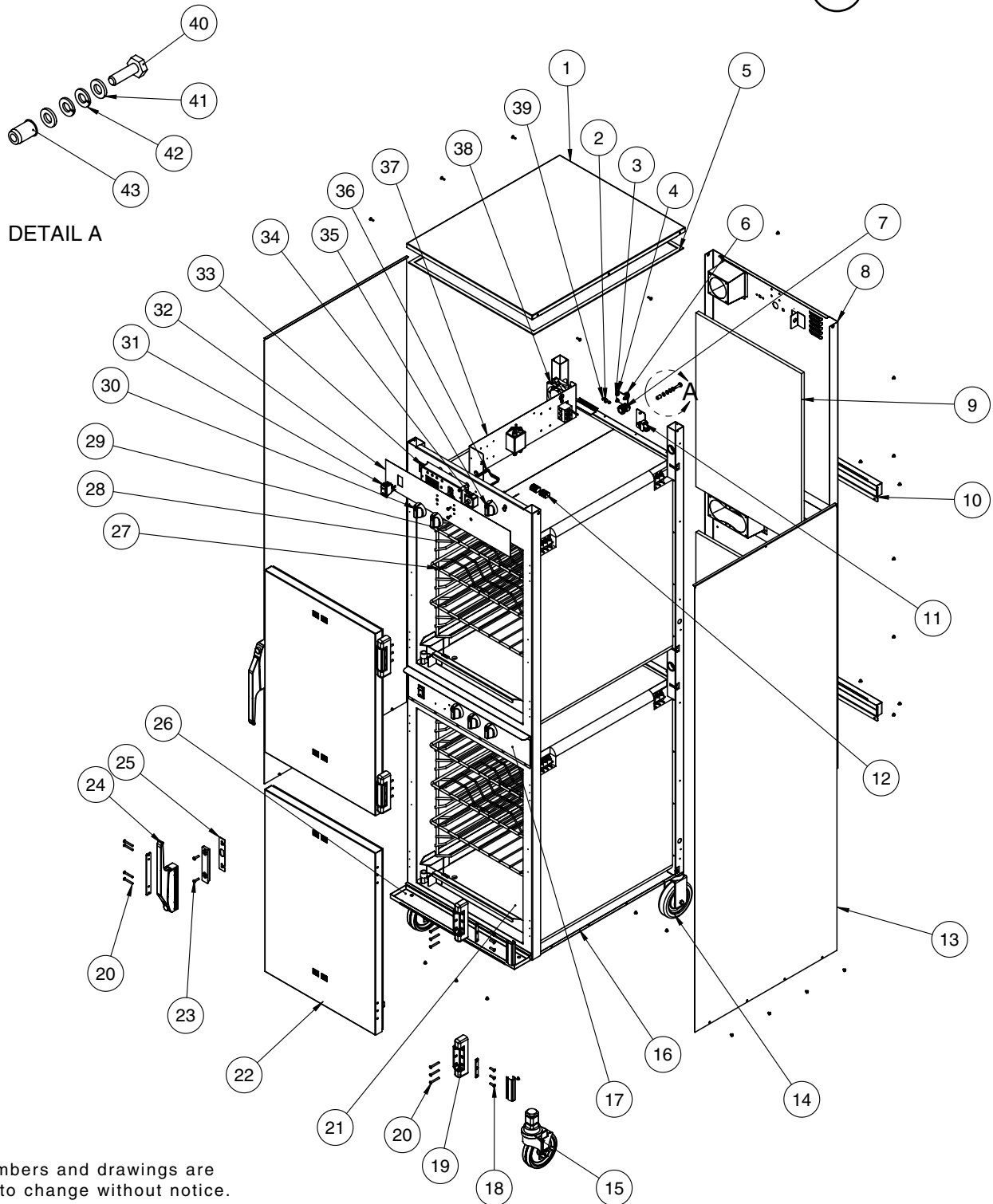

DANGER



**LOCK-OUT OR POST
BREAKER PANEL UNTIL
SERVICE WORK HAS
BEEN COMPLETED.**



DANGER



**DISCONNECT UNIT FROM
POWER SOURCE BEFORE
CLEANING OR SERVICING.**

EXTERIOR PARTS LIST - DOUBLE COMPARTMENT

B

		MODEL >	1767-SK		1000-SK-I	
ITEM	DESCRIPTION	PART NO.	QTY	PART NO.	QTY	
1	TOP COVER	1011872	1	1011534	1	
2	PLUG, HOLE 3/8"	PG-25574	2	PG-25574	2	
3	SCREW, 10-32 X 1/2", NF PHIL, FLAT	SC-23670	4	SC-23670	4	
4	NUT, 10-32 UNF HEX MS, 18-8 SST	NU-2215	4	NU-2215	4	
5	GASKETS, ADHESIVE, .125 X .375 [linear ft]	GS-23622	1	GS-23622	1	
6	BRACKET, TETHER	BT-26884	1	BT-26884	1	
7	BUSHING, STRAIGHT, STRAIN RELIEF	BU-3964	1	BU-3964	1	
8	REAR TRIM	5014223	1	5014293	1	
9	INSULATION	IN-2003	2	IN-2003	2	
10	ELEMENT COVER, SMOKER	1010409	2	1011813	2	
11	SWITCH COVER	11133	1	11133	1	
12	CONNECTOR-5 CONDUCTOR	CR-34646	2	CR-34646	3	
13	SIDE PANEL	1012652	2	1011533	2	
14	CASTER, 1.5" STEM, RIGID 5"	CS-24874	2	CS-24874	2	
15	CASTER, 1.5" STEM, 5" SWIVEL WITH BRAKE	CS-24875	2	CS-24875	2	
16	BOTTOM PANEL	1010394	1	1009941	1	
17	MIDDLE BONNET ASSEMBLY	5013052	1	5013230	1	
18	SCREW, 10-32 X 3/4", NF PHIL, FLAT M/S, 18-8 S/S	SC-2072	12	SC-2072	12	
19	HINGE, 1-3/8" OFFSET, PAIR, CHROME	HG-22338	2	HG-22338	2	
20	SCREW, 10-32X1-1/2", NF, PHIL, FLAT M/S,18-8 S/S	SC-2073	20	SC-2073	20	
21	DRIP PAN WELD	14831	2	5005616	2	
22	DOOR ASSEMBLY	5011828	1	5012859	2	
23	SCREW, 10-32 X 3/4" PHILLIPS PAN HD	SC-2071	4	SC-2071	4	
24	HANDLE, OFFSET MAGNETIC LATCH	HD-27080	2	HD-27080	2	
25	SHIM, HANDLE	13947	2	13947	2	
26	DRIP TRAY KIT	5010391	1	5009716	1	
	- DRIP TRAY	1010584	1	1010189	1	
	- DRIP TRAY BRACKET	1010585	1	1010188	1	
27	SHELF, RIB RACK	SH-2743	2	SH-29474	2	
28	SIDE RACK	SR-28405	4	SR-2266	4	
	PAN SLIDES, 230V ONLY	1010813	4	—	—	
29	SHELF, WIRE S/S	SH-2324	4	SH-2325	4	
30	KNOB	KN-26568	3	KN-26568	3	
31	SWITCH, ROCKER, 20A	SW-34769	1	SW-34769	1	
32	PANEL OVERLAY	PE-29361	1	PE-29383	1	
33	CONTROL	CC-34488	1	CC-34488	1	
34	THERMOSTAT, COOK	TT-34910	1	TT-34910	1	
35	TIMER, 1 HR	TR-34539	1	TR-34539	1	
36	CABLE WIRE HARNESS	CB-34945	1	CB-34945	1	
37	ELECTRIC CHASSIS	5014319	1	5014319	1	
38	FAN, BOX, 208-240V, 230V	FA-34524	3	FA-34524	3	
39	PLUG, DOME, 187" HOLE	PG-28439	4	PG-28439	4	
40	SCREW, HHCS, M6 X 20, W/NO MARKING	SC-22924	1	SC-22924	1	
41	WASHER, FLAT, M6, DIN 125	WS-22297	2	WS-22297	2	
42	WASHER, M6 SPLIT LOCK S/S 18-8	WS-22302	2	WS-22302	2	
43	NUT, THREADED INSERT, M6	NU-22770	1	NU-22770	1	
44*	CHIP TRAY WELD	4652R	2	4652R	2	
45*	BRACKET, PILOT LIGHT	1004360	1	1004360	1	
46*	NON-PRODUCT PROBE SEAL	1006871	2	1006871	3	
47*	BRACKET, SENSOR MOUNTING	1008272	2	1008272	3	
48*	AIR SHIELD	1011925	1	1011925	1	
49*	SMOKE HEATER PLATE WELD	5003782	1	5003782	2	
50*	CABLE INSULATION	5014325	1	5014315	1	
51*	BLOCK, SENSOR	BK-27878	1	BK-27878	3	
52*	BLOCK, TERMINAL, PORCELAIN	BK-33546	1	BK-33546	1	
53*	BRACKET, CHIP TRAY	BT-29217	2	BT-29217	2	
54*	BUSHING, SNAP 1-1/8"	BU-3378	8	BU-3378	8	
55*	BUSHING, BLACK, 5/8" SNAP	BU-3611	4	BU-3611	4	
56*	CONNECTOR	CR-34559	2	CR-34559	2	
57*	PILOT LIGHT	LI-3951	1	LI-3951	1	
58*	NUT, HEX M4-0.7 18-8	NU-22286	2	NU-22286	2	
59*	NUT, HEX #8-32	NU-2296	2	NU-2296	2	
60*	NUT, 1/4-20 HEX S/S	NU-2437	4	NU-2437	4	
61*	SENSOR, OVEN TEMPERATURE	PR-34494	2	PR-34494	3	
62*	RIVET, BLIND, #44, S/S	RI-2100	12	RI-2100	12	
63*	SCREW, 6-32 X 1/2", NC PHIL, FLAT	SC-2239	4	SC-2239	6	
64*	SCREW, 8-32 X 2" SLOT PAN HEAD 18-8 S/S	SC-23154	6	SC-23154	8	
65*	SCREW, 8-32 X 1/2" PHIL SCREW	SC-2425	16	SC-2425	20	
66*	SCREW, 8-32 X 1/4" PHIL	SC-2459	34	SC-2459	41	
67*	SWITCH, TOGGLE, VOLTAGE	SW-3528	1	SW-3528	1	
68*	WASHER M4 SPIT LOCK S/S 18-8	WS-22300	2	WS-22300	2	

*NOT SHOWN

SERVICE

ELECTRONIC COMPONENTS - 767-SK, 120V SHOWN

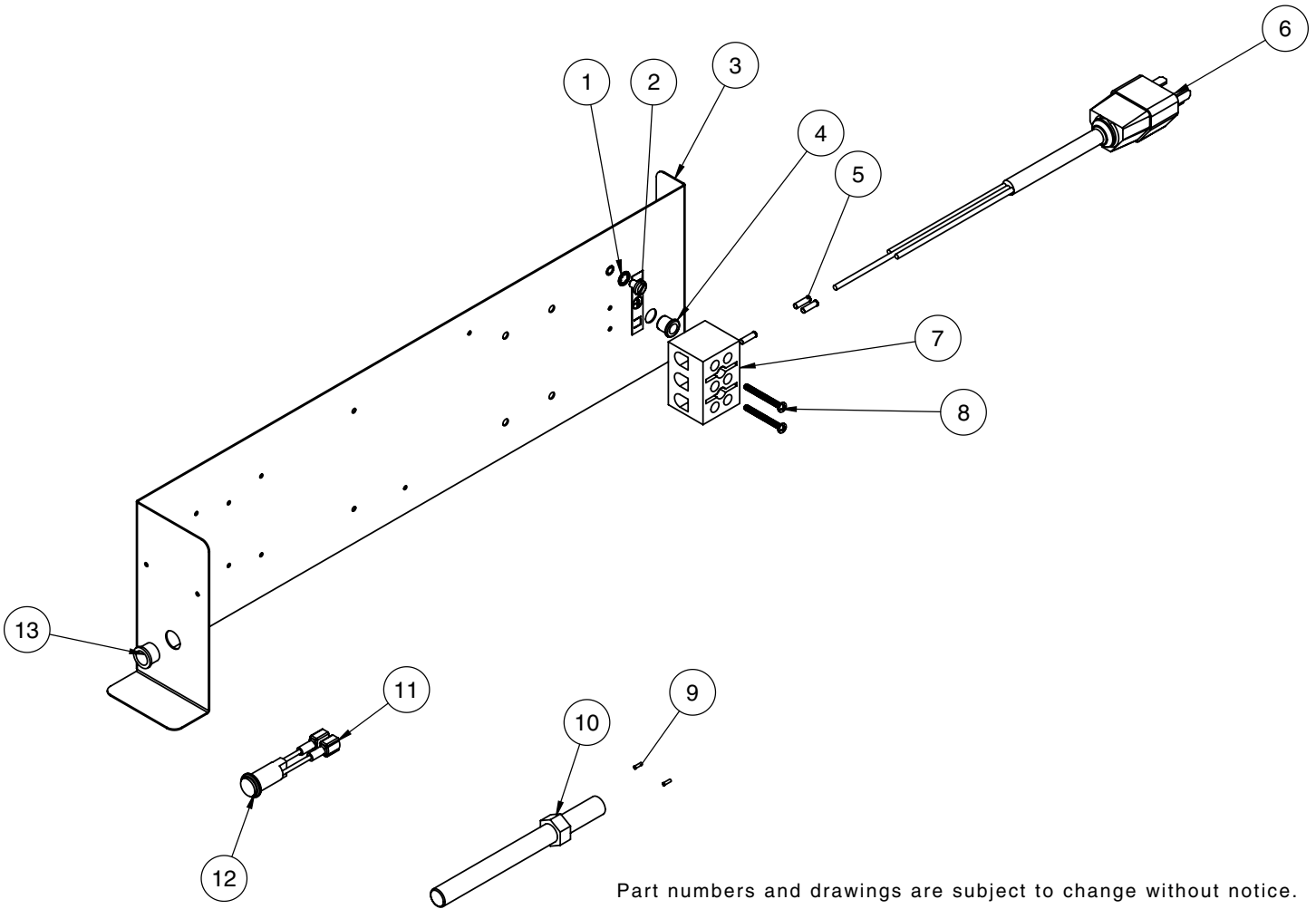

Part numbers and drawings are subject to change without notice.

ITEM	DESCRIPTION	PART NO.	QTY	ITEM	DESCRIPTION	PART NO.	QTY
1	STAR LOCK WASHER	WS-2467	1	9	CONNECTOR, FERRULE #18	CR-34827	2**
2	GROUND SCREW	SC-2190	1	10	ELEMENT SMOKE, 208-240V, 230V	EL-35022	1**
3	ELECTRIC CHASSIS	5014097	1		ELEMENT, SMOKE, 120V	EL-35023	1**
4	BUSHING, 3/8 BLACK HOLE	BU-3419	1	11	CONNECTOR, QUICK DISCONNECT	CR-34638	2
5	CONNECTOR, FERRULE #12	CR-34830	3	12	PILOT LIGHT, WHITE, 110V	LI-3951	1
6	CORDSET, 120V	CD-3397	1	13	BUSHING, 1/2 HOLE	BU-3006	1
	CORDSET, 230V	CD-3922	1	14*	LINE FILTER (230V ONLY)	FI-33225	1
7	T-BLOCK	BK-3019	1	15*	SCREW, LINE FILTER (230V ONLY)	SC-2459	2
8	SCREW, 6-32 X 1-1/4 ROUND HD	SC-2365	2				

*NOT SHOWN

**QUANTITY PER COMPARTMENT

DANGER

LOCK-OUT OR POST
BREAKER PANEL UNTIL
SERVICE WORK HAS
BEEN COMPLETED.

DANGER

DISCONNECT UNIT FROM
POWER SOURCE BEFORE
CLEANING OR SERVICING.

SERVICE

MID BONNET ASSEMBLY - 1767-SK SHOWN

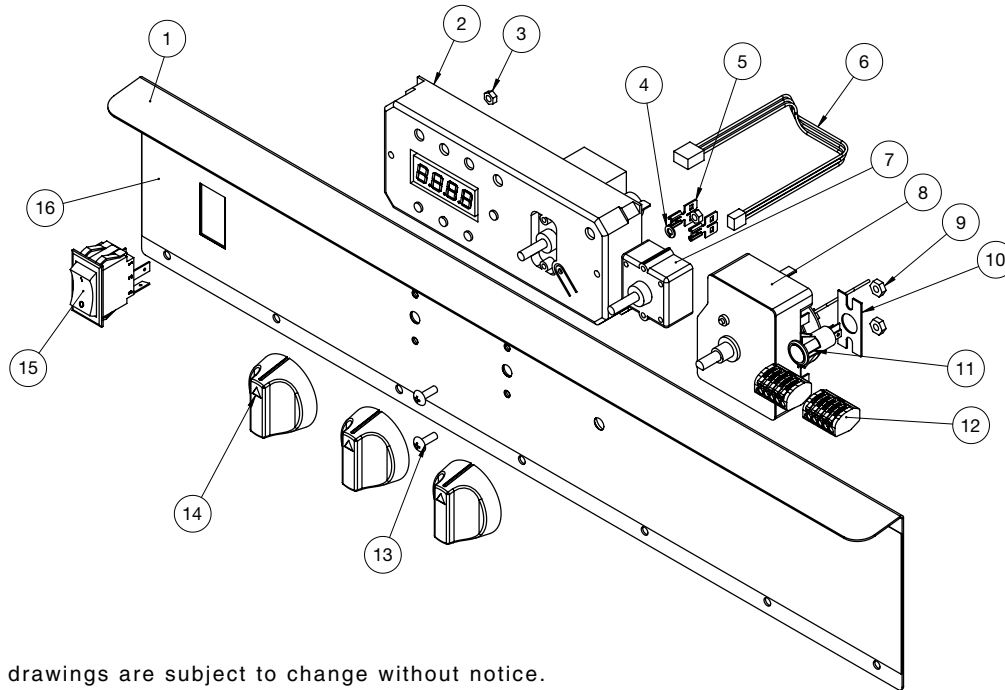

Part numbers and drawings are subject to change without notice.

ITEM	DESCRIPTION	PART NO.	QTY	ITEM	DESCRIPTION	PART NO.	QTY
1	MID-BONNET SPOT ASSB	5012422	1	9	NUT, HEX #8-32	NU-2296	2
2	CONTROL	CC-34488	1	10	BRACKET, PILOT LIGHT MTG	1004360	1
3	NUT, M4-0.7 HEX 18-8	NU-2296	2	11	PILOT LIGHT, WHITE, 250V	LI-3951	1
4	WASHER, M4 SPLIT LOCK S/S 18-8	WS-22300	2	12	CONNECTOR-5 CONDUCTOR	CR-34646	2
5	CONNECTOR	CR-34559	2	13	SCREW, 8-32 X 1/2", PHIL	SC-2425	2
6	CABLE, WIRE HARNESS	CB-34945	1	14	KNOB, T-STAT CONTROL	KN-26568	3
7	THERMOSTAT, COOK	TT-34910	1	15	SWITCH, ROCKER, 125-277V, 20A	SW-34769	1
8	TIMER, 1HR, 208/240V	TR-34539	1	16	OVERLAY, MID BONNET CONTROL	PE-29441	1

CABLE HEATING KITS

CABLE HEATING KIT > (ONE KIT REQUIRED PER CAVITY)		#4878 120V	#4881 208-240V 230V
ITEM	DESCRIPTION	QTY	QTY
CB-3045	CABLE HEATING ELEMENT	112 FT.	210 FT.
CR-3226	RING CONNECTOR	6	12
IN-3488	INSULATION CORNER	1 FT.	1 FT.
BU-3105	SHOULDER BUSHING	6	12
BU-3106	CUP BUSHING	6	12
ST-2439	STUD	6	12
NU-2215	HEX NUT	12	24
SL-3063	INSULATING SLEEVE	6	12
TA-3540	ELECTRICAL TAPE	1 ROLL	1 ROLL



DANGER



**LOCK-OUT OR POST
BREAKER PANEL UNTIL
SERVICE WORK HAS
BEEN COMPLETED.**



DANGER



**DISCONNECT UNIT FROM
POWER SOURCE BEFORE
CLEANING OR SERVICING.**

(FRONT)

VIEW IS FROM REAR OF UNIT

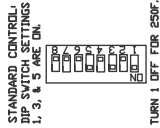
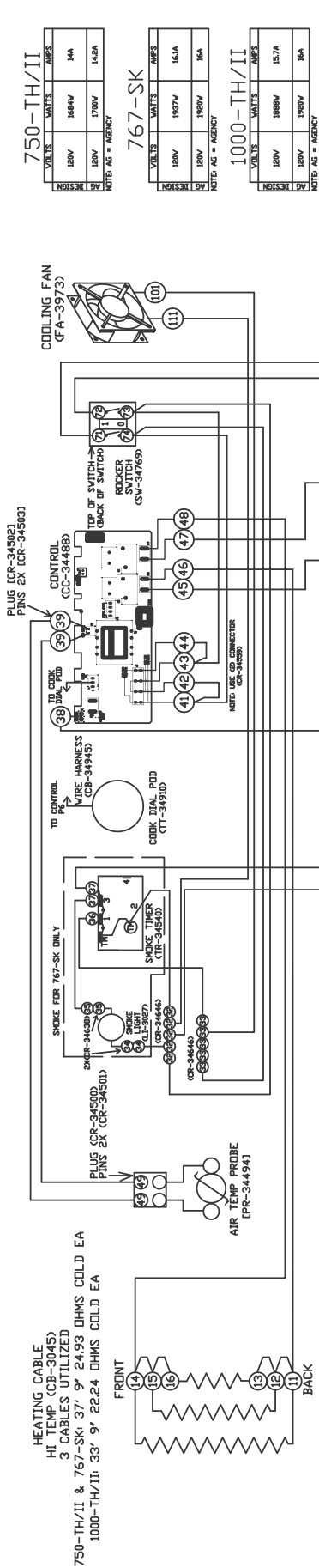

750-TH/II

VALUES	AMPS
180V	168VA
180V	170VA
180V	14.8A
NOTE: AS = AGENCY	

767-SK

VALUES	AMPS
180V	1997VA
180V	16.1A
180V	16A
NOTE: AS = AGENCY	

1000-TH/II

VALUES	AMPS
180V	1888VA
180V	15.7A
180V	16A
NOTE: AS = AGENCY	

WIRE ASSEMBLIES:
SEE 5012383 FOR MAIN WIRE ASSEMBLY
SEE 5012386 FOR SMOKE OPTION WIRE ASSEMBLY

4	59726	CHANGE SMOKE ELEMENT E-24553 TO E-25023 - REDUCE ELEMENT POWER	2-28-11	JPK
3	-	ADD CR-34638 TO FAN WIRES	2-9-11	JPK
2	-	FIX SMOKE LIGHT P/N	12-16-10	JPK
REV	ECO	DESCRIPTION	DATE	APP
750,1000-TH/II, 767-SK 120V 60HZ				
ALTO-SHAAM			DWG:	77359
			BY:	JPK DATE: 6/23/10
			WIRING DIAGRAM	
			SHEET	
			1_DF_1	

(REAR)

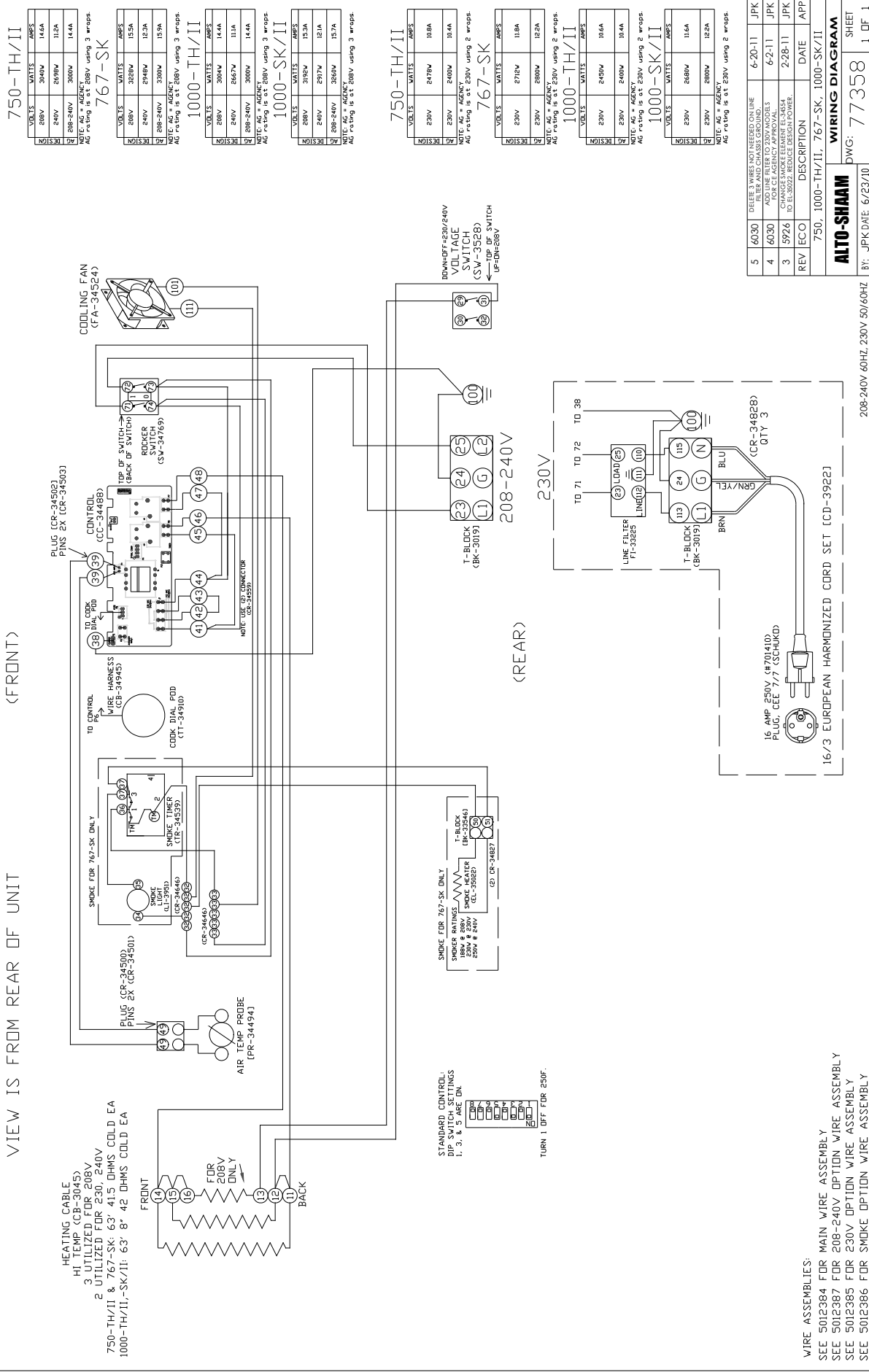

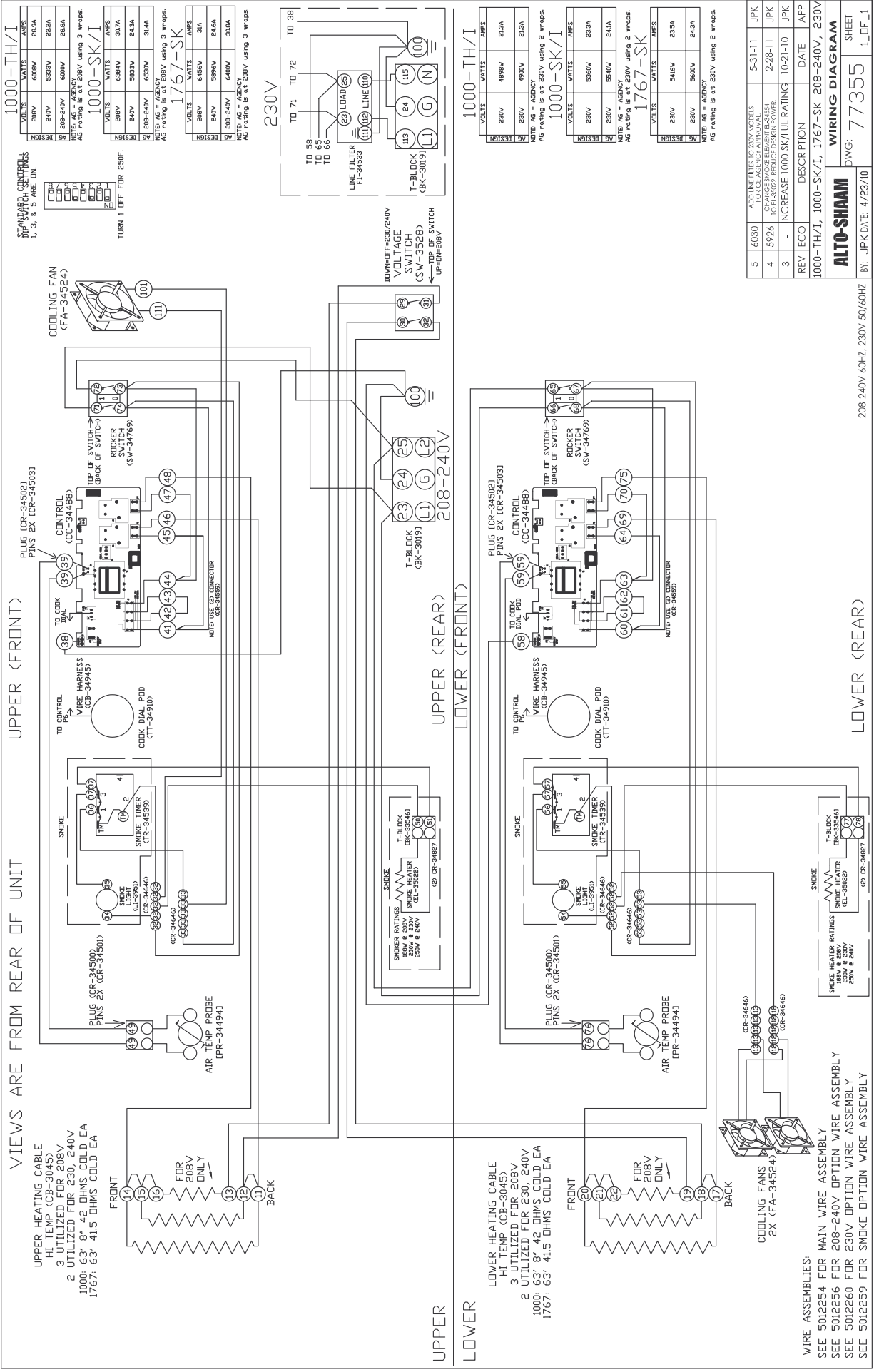

5	6030	ADD LINE FILTER TO 230V MODELS AS CALLED FOR IN PART 34554	5-31-11	JPK
4	5926	CHANGE FROM EL-5951 TO EL-5952. REDUCE DESIGN POWER.	2-28-11	JPK
3	-	INCREASE 1000-SK/I UL RATING	10-21-10	JPK
REV	ECO	DESCRIPTION	DATE	APP

1000-TH/I, 1000-SK/I, 1767-SK 208-240V, 230V

ALTO-SHAAM DWG: 77355 SHEET 1_OF_1

BY: JPK DATE: 4/23/10

TRANSPORTATION DAMAGE and CLAIMS



All Alto-Shaam equipment is sold F.O.B. shipping point, and when accepted by the carrier, such shipments become the property of the consignee.

Should damage occur in shipment, it is a matter between the carrier and the consignee. In such cases, the carrier is assumed to be responsible for the safe delivery of the merchandise, unless negligence can be established on the part of the shipper.

1. Make an immediate inspection while the equipment is still in the truck or immediately after it is moved to the receiving area. Do not wait until after the material is moved to a storage area.
2. Do not sign a delivery receipt or a freight bill until you have made a proper count and inspection of all merchandise received.
3. Note all damage to packages directly on the carrier's delivery receipt.
4. Make certain the driver signs this receipt. If he refuses to sign, make a notation of this refusal on the receipt.
5. If the driver refuses to allow inspection, write the following on the delivery receipt:
Driver refuses to allow inspection of containers for visible damage.
6. Telephone the carrier's office immediately upon finding damage, and request an inspection. Mail a written confirmation of the time, date, and the person called.
7. Save any packages and packing material for further inspection by the carrier.
8. Promptly file a written claim with the carrier and attach copies of all supporting paperwork.

We will continue our policy of assisting our customers in collecting claims which have been properly filed and actively pursued. We cannot, however, file any damage claims for you, assume the responsibility of any claims, or accept deductions in payment for such claims.

LIMITED WARRANTY

Alto-Shaam, Inc. warrants to the original purchaser only that any original part that is found to be defective in material or workmanship will, at Alto-Shaam's option, subject to provisions hereinafter stated, be replaced with a new or rebuilt part.

The parts warranty period is as follows:

For the refrigeration compressor on Alto-Shaam Quickchillers™, five (5) years from the date of installation.

For the heating element on Halo Heat® cooking and holding ovens, as long as the original purchaser owns the oven. This excludes holding only equipment.

For all other parts, one (1) year from the date of installation or fifteen (15) months from the shipping date, whichever occurs first.

The labor warranty period is one (1) year from the date of installation or fifteen (15) months from the shipping date, whichever occurs first.

Alto-Shaam will bear normal labor charges performed during standard business hours, excluding overtime, holiday rates or any additional fees.

To be valid, a warranty claim must be asserted during the applicable warranty period. This warranty is not transferable.

THIS WARRANTY DOES NOT APPLY TO:

1. Calibration.
2. Replacement of light bulbs, door gaskets, and/or the replacement of glass due to damage of any kind.
3. Equipment damage caused by accident, shipping, improper installation or alteration.
4. Equipment used under conditions of abuse, misuse, carelessness or abnormal conditions, including but not limited to, equipment subjected to harsh or inappropriate chemicals, including but not limited to, compounds containing chloride or quaternary salts, poor water quality, or equipment with missing or altered serial numbers.
5. Damage incurred as a direct result of poor water quality, inadequate maintenance of steam generators and/or surfaces affected by water quality. Water quality and required maintenance of steam generating equipment is the responsibility of the owner/operator.
6. Damage caused by use of any cleaning agent other than Alto-Shaam's Combitherm® Cleaner, including but not limited to damage due to chlorine or other harmful chemicals. **Use of Alto-Shaam's Combitherm® Cleaner on Combitherm® ovens is highly recommended.**
7. Any losses or damage resulting from malfunction, including loss of product, food product, revenue, or consequential or incidental damages of any kind.
8. Equipment modified in any manner from original model, substitution of parts other than factory authorized parts, removal of any parts including legs, or addition of any parts.

This warranty is exclusive and is in lieu of all other warranties, express or implied, including the implied warranties of merchantability and fitness for a particular purpose. In no event shall Alto-Shaam be liable for loss of use, loss of revenue or profit, or loss of product, or for any indirect, special, incidental, or consequential damages. No person except an officer of Alto-Shaam, Inc. is authorized to modify this warranty or to incur on behalf of Alto-Shaam any other obligation or liability in connection with Alto-Shaam equipment.



Effective November 1, 2011

RECORD THE MODEL AND SERIAL NUMBER OF THE APPLIANCE FOR EASY REFERENCE.

ALWAYS REFER TO BOTH MODEL AND SERIAL NUMBER IN ANY CONTACT WITH ALTO-SHAAM REGARDING THIS APPLIANCE.

Model: _____ Date Installed: _____
Voltage: _____ Purchased From: _____
Serial Number: _____

W164 N9221 Water Street • P.O. Box 450 • Menomonee Falls, Wisconsin 53052-0450 • U.S.A.
PHONE: 262.251.3800 • 800.558-8744 USA/CANADA FAX: 262.251.7067 • 800.329.8744 U.S.A. ONLY

www.alto-shaam.com

PRINTED IN U.S.A.