

Operating Instructions

High Speed Color Scanner

Model No. **KV-S3065CL / KV-S3065CW**

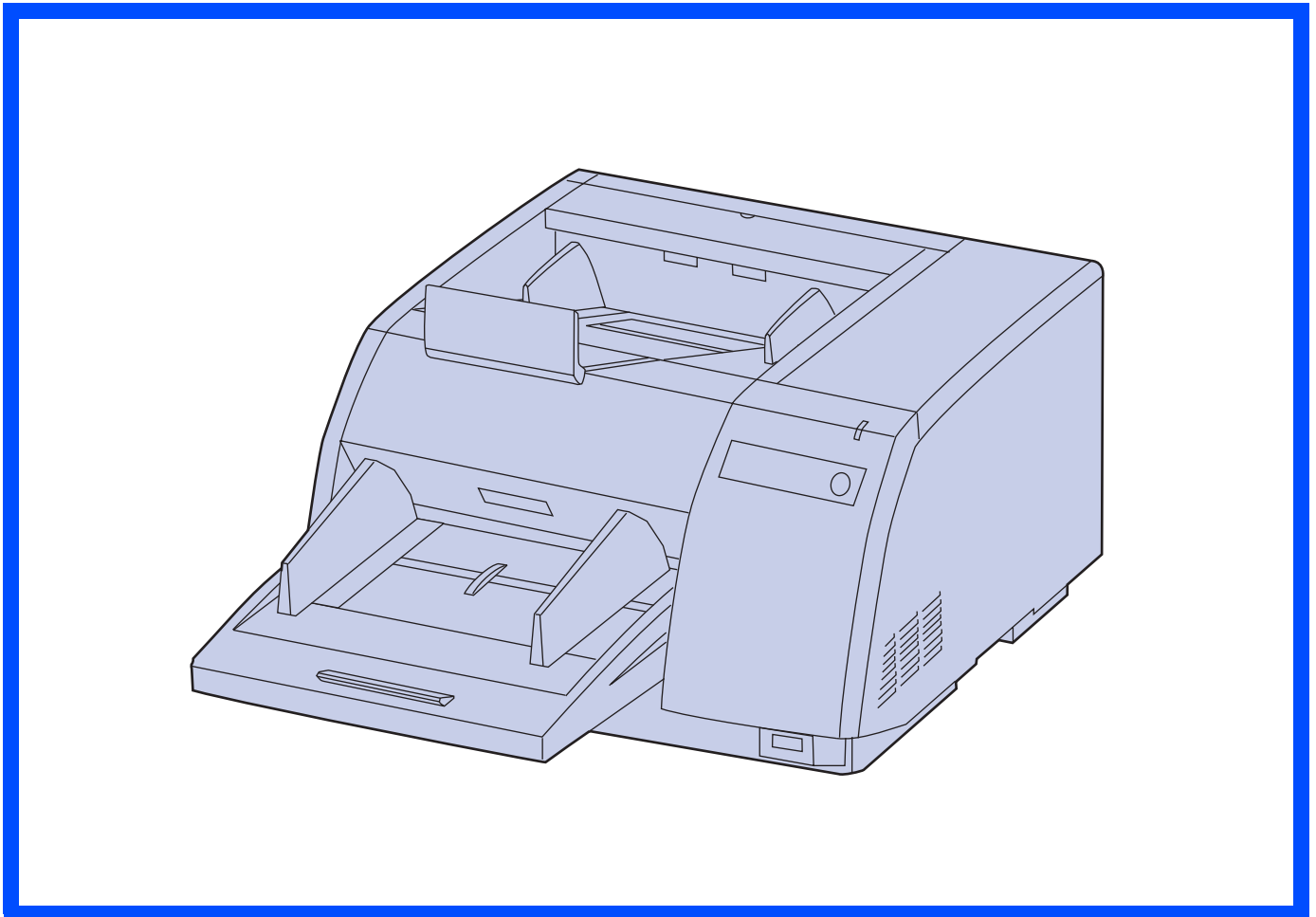

These instructions contain information on operating the scanner. Before reading these instructions, please read the installation manual enclosed with this unit.

Please carefully read these instructions, the enclosed installation manual and maintenance manual. Keep all documentation in a safe place for future reference. Keep the CD-ROM in the protective case. Do not expose the CD-ROM to direct sunlight or extreme heat and do not scratch or smudge the surface of the CD-ROM.

Thank you for purchasing a Panasonic “High Speed Color Scanner.”

- Panasonic supports your imaging needs with a reliable and easy to use document scanner.
- Panasonic has developed Panasonic Image Enhancement Technology to improve the quality of your scanned images even beyond the quality of your original document.

■ System requirements

When using the scanner, the required host computer conditions are as follows.

	SCSI Connection	USB Connection
CPU	Minimum Pentium® III, 1 GHz Recommended Pentium 4, 2 GHz or higher	
Memory	Minimum 256 MB Recommended 512 MB or higher	
OS	Windows® 98* ¹ / Windows NT®* ³ 4.0 / Windows 2000* ⁴ / Windows Me* ² / Windows XP* ⁵	Windows 98 / Windows 2000 / Windows Me / Windows XP
Display	1024×768 dots or more, 65536 colors or more	
Interface	SCSI III Recommended SCSI board Adaptec SCSI 2930U / 2940U / 29160N /19160	USB 2.0

*¹ Microsoft® Windows 98 operating system (hereafter Windows 98)

*² Microsoft Windows Millennium Edition operating system (hereafter Windows Me)

*³ Microsoft Windows NT operating system (hereafter Windows NT)

*⁴ Microsoft Windows 2000 operating system (hereafter Windows 2000)

*⁵ Microsoft Windows XP operating system (hereafter Windows XP)

※ 1 GB or more free space is required in the HDD.

※ Color images larger than A3 size cannot be scanned in 600 dpi on Windows 98 or Windows Me. A large size color image may not be scanned in high resolution depending on a computer system or application.

※ The scanning speed differs depending on the host computer operating environment or application.

※ Windows NT 4.0 does not support USB interface.

※ For Windows NT 4.0, you must install the ASPI layer software that the SCSI board vender provides.

※ Use USB 2.0 interface because scanning speed of USB 1.1 interface is slow.

※ If you connect the scanner to a USB hub, it is not guaranteed to work.

※ When using the scanner with other SCSI devices connected by daisy chain connection, it is not guaranteed to work.

Important

- Do not duplicate currency.
- Do not duplicate copyrighted material or the work of others except for the purpose of private use.
- Do not duplicate any kind of certificates, licenses, passports, official or private documents, and the like.



As an ENERGY STAR® Partner, Panasonic has determined that this product meets the ENERGY STAR guidelines for energy efficiency.
(ENERGY STAR and the ENERGY STAR certification mark are registered US marks.)

- Microsoft, Windows and Windows NT are either registered trademarks or trademarks of Microsoft Corporation in the United States and/or other countries.
- ISIS is a registered trademark of Pixel Translations, a division of Captiva Software Corporation.
- Pentium is a trademark or registered trademark of Intel Corporation or its subsidiaries in the United States and other countries.
- Adaptec is a registered trademark of Adaptec, Inc.
- Each company's name or company product name is each company's trademark or registered trademark.

The information given in these Operating Instructions is subject to change without notice.

Table of Contents

Page

Before You Start

Notice	4
Precautions	7
Component Identification	10
• Power turn-on sequence	11
• About LED	11
• About the SCSI setting (Not required for USB connection)	12

Operation

Loading Documents	13
• When scanning multiple sheets	14
Paper Feed Settings	17
• Selecting the paper path for scanned document	17
• Setting the ADF / manual feed selector	17
Others	18
• How to use the control sheet and separation sheet	18
Changing the Reference Plate Setting	19
• Reference plate setting	19

Care and Maintenance

Clearing Paper Jams	21
• Removing paper jams from the scanner	21
• Removing paper jams from the exit path	21
Cleaning the Unit	22
• Outside of the scanner	22
• Inside the scanner	22
• Roller cleaning paper	22
• Cleaning the rollers	23
• Cleaning the sensors, reflectors, double feed detectors and image sensor covers	25
Replacing Consumables	27
• Replacing paper feed roller module	27
• Replacing retard roller module	29
Shading Adjustment	32

Appendix

Repacking Instructions	33
Specifications	34
Troubleshooting	36
Index	38

Notice

English

WARNING:

TO PREVENT FIRE OR SHOCK HAZARD, DO NOT EXPOSE THIS PRODUCT TO RAIN OR ANY TYPE OF MOISTURE.

THE SOCKET-OUTLET MUST BE NEAR THIS EQUIPMENT AND MUST BE EASILY ACCESSIBLE.

The product should be used only with a power cord that is supplied by the manufacturer.

Power Source

WARNING

- (220-240 V equipment)
A certified power supply cord has to be used with this equipment. The relevant national installation and/or equipment regulations shall be considered. A certified power supply cord not lighter than ordinary polyvinyl chloride flexible cord according to IEC 60227 (designation H05VV-F 3G 1.0 mm²).

Roller cleaning paper precautions

Before using the roller cleaning paper, please read these instructions completely. Keep these instructions for future reference.

WARNING

- Do not drink or inhale the roller cleaning paper fluid including isopropyl alcohol.
- The roller cleaning paper may be harmful to sensitive skin. Please use protective gloves.
- Do not use the roller cleaning paper near a heater or open flame.
- Do not store the roller cleaning paper in direct sunlight or in a place with temperature over 40 °C (104 °F).
- Only use the roller cleaning paper to clean the rollers and scanning area.
- If you need more information about the roller cleaning paper, please refer to the Material Safety Data Sheet (MSDS).
- Please ask your Panasonic sales company about obtaining the Material Safety Data Sheet.

KEEP AWAY FROM FIRE.

Federal Communications Commission Requirements

(For United States only)



Note: This equipment has been tested and found to comply with the limits for a Class A digital device, pursuant to part 15 of the FCC Rules. These limits are designed to provide reasonable protection against harmful interference when the equipment is operated in a commercial environment. This equipment generates, uses, and can radiate radio frequency energy and, if not installed and used in accordance with the instruction manual, may cause harmful interference to radio communications. Operation of this equipment in a residential area is likely to cause harmful interference in which case the user will be required to correct the interference at his own expense.

FCC Warning: To assure continued FCC compliance, the user must use only shielded interface cable and the provided power supply cord. Also, any unauthorized changes or modifications to this equipment would void the user's authority to operate this device.

(For United Kingdom only)

For your safety please read the following text carefully.

This appliance is supplied with a moulded three pin mains plug for your safety and convenience.

A 5 amp. fuse is fitted in this plug. Should the fuse need to be replaced, please ensure that the replacement fuse has a rating of 5 amps. and that it is approved by ASTA or BSI to BS1362. Check for the ASTA mark  or the BSI mark  on the body of the fuse. If the plug contains a removable fuse cover you must ensure that it is refitted when the fuse is replaced. If you lose the fuse cover the plug must not be used until a replacement cover is obtained. A replacement fuse cover can be purchased from your local Panasonic Dealer.

If the fitted moulded plug is unsuitable for the socket outlet in your home then the fuse should be removed and the plug cut off and disposed of safely.

There is danger of severe electrical shock if the cut off plug is inserted into any 13 amp. socket.

If a new plug is to be fitted please observe the wiring code as shown below. If in any doubt please consult a qualified electrician.

WARNING: This appliance must be earthed.

IMPORTANT: The wires in this mains lead are coloured in accordance with the following code.

Green-and-Yellow	: Earth
Blue	: Neutral
Brown	: Live

As the colours of the wire in the mains lead of this appliance may not correspond with the coloured markings identifying the terminals in your plug, proceed as follows.

The wire which is coloured Green-and-Yellow must be connected to the terminal in the plug which is marked with the letter E or by the Earth symbol  or coloured Green-and-Yellow.

The wire which is coloured Blue must be connected to the terminal in the plug which is marked with the letter N or coloured Black.

The wire which is coloured Brown must be connected to the terminal in the plug which is marked with the letter L or coloured Red.

How to replace the fuse:

Open the fuse compartment with a screwdriver and replace the fuse.

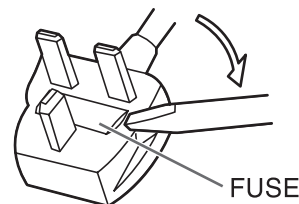

在臺灣的使用者

警告

為防止發生火災和電擊，切勿將本機置於會遭到雨淋或其他任何類型的潮濕環境中。

電源插座務必要靠近本設備而且必須便於插拔。

警告使用者

這是甲類的資訊產品，在居住的環境中使用時，可能會造成射頻干擾，在這種情況下，使用者會被要求採取某些適當的對策。

警告

- 切勿將含有異丙醇的靛清潔紙液誤飲或吸入。
 - 靛清潔紙可能對敏感的皮膚有害，因此請戴上防護手套使用。
 - 切勿靠近加熱器具或明火使用靛清潔紙。
 - 切勿將靛清潔紙在陽光直射或溫度超過40°C之處保管。
 - 只能使用靛清潔紙來清潔靛和掃描區域。
 - 有關靛清潔紙的具體細節請參閱材料安全數據表(MSDS)。
 - 關於獲取材料安全數據表的方法請向Panasonic銷售公司洽詢。
- 遠離火源。

Caution Labels

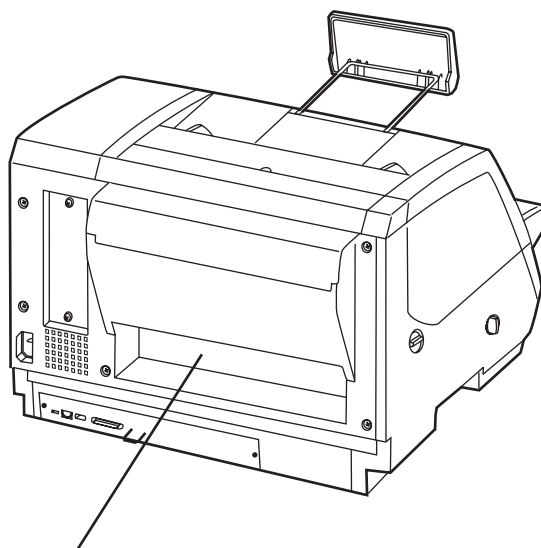



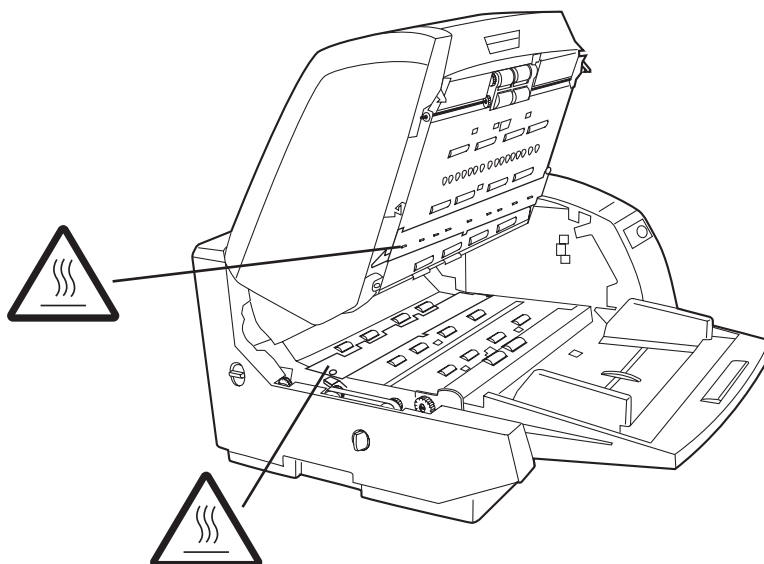





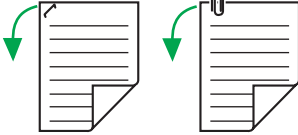

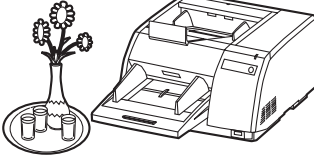

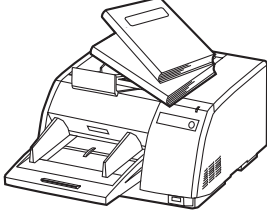

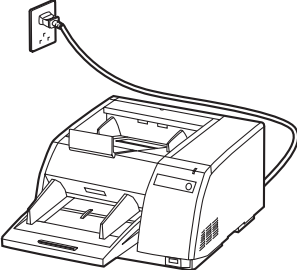

 CAUTION	 VORSICHT	 ATTENTION
 DO NOT TOUCH THE ROLLER. THIS MAY CAUSE PERSONAL INJURY.	 NICHT DIE ROLLE BERÜHREN. VERLETZUNGSGEFAHR.	 NE PAS TOUCHER LE ROULEAU. RISQUE DE BLESSURES.

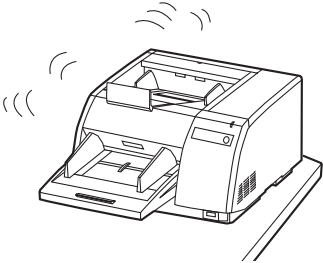

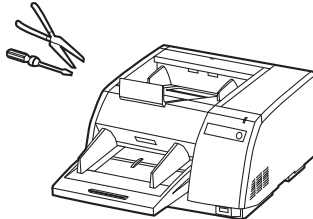
Precautions

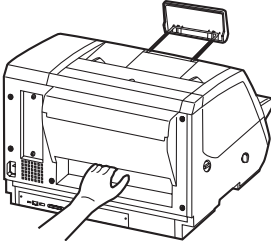
The following precautions are recommended to extend the life of the unit:

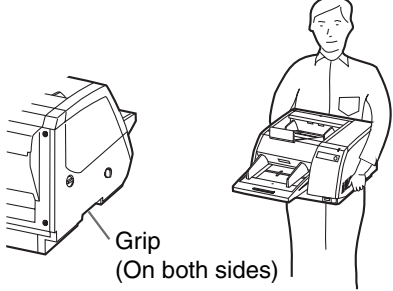
<p>Prior to scanning, remove all staples and paper clips from pages.</p>  	<p>Do not place any liquids near the unit.</p> <p>—Accidental spillage of liquid into the unit may cause severe damage. If this occurs, turn the unit off, unplug the power cord and call for service.</p>  	<p>Do not place books, paper, or other items on the unit.</p>  
<p>Do not place the unit in an area where there is a lot of smoke, dust, chemical fumes or vibration.</p>   <p>Ex: Thinner</p>  <p>Ex:</p>	<p>Do not leave the power cord plugged into the AC outlet if the unit will not be used for an extended period.</p>  	
<p>Do not place the unit on an uneven or unstable surface.</p>  	<p>Do not disassemble the unit. This will void your warranty.</p>  	
<p>Do not insert your fingers into the back opening in the scanner.</p>  	<p>When carrying the unit, please hold both side grips.</p>   <p>Grip (On both sides)</p>	

- Special care should be taken to protect the unit if it is used in a less than optimum environment, such as a dusty or sandy area.

Precautions

Operating Environment

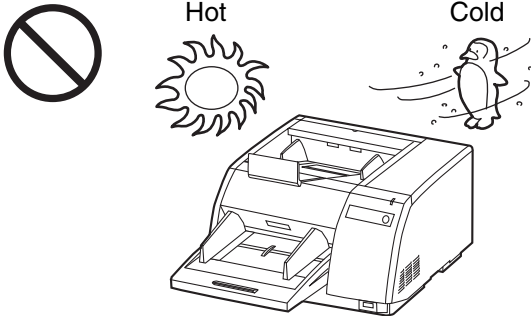
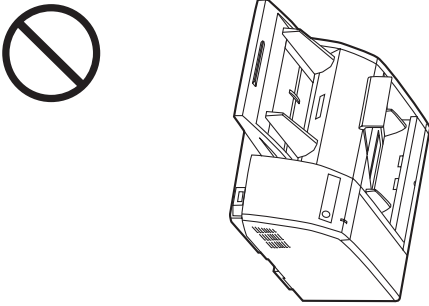
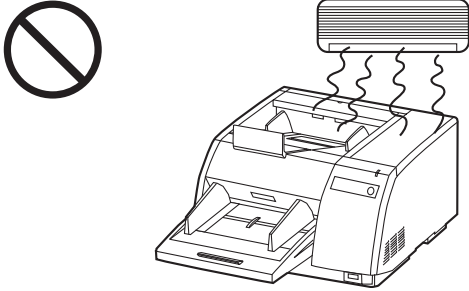
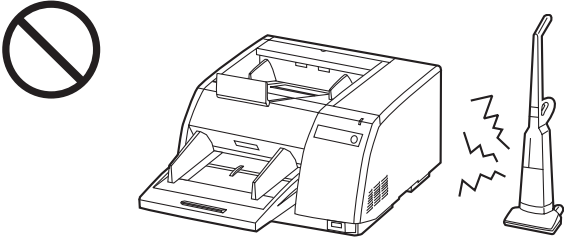
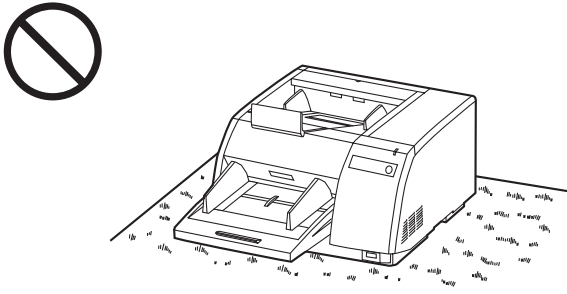
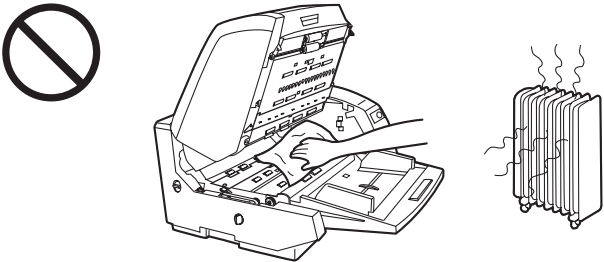
<p>Do not place the unit in direct sunlight or in a cold draft.</p> 	<p>Do not operate or place the unit in a vertical position.</p> 
<p>Do not place the unit near a heating appliance or an air conditioning vent. Do not place the unit in a room with extremely high or low humidity.</p> 	<p>Do not place the unit near other appliances which generate large electrical noise.</p> 
<p>Do not place the unit on a carpet. (Static electricity can cause the unit to malfunction.)</p> 	<p>Do not drink or inhale the included roller cleaning paper fluid. The roller cleaning paper may be harmful to sensitive skin. Please use protective gloves. Do not use the roller cleaning paper near a heater or open flame. This may cause a fire.</p> 

●Power Source

- Use a voltage level that does not vary more than $\pm 10\%$ from the voltage level marked on the nameplate (located on the back side of the scanner).
- Do not use an extension cord.
- This scanner should be connected to a grounded outlet.
- Do not use a line conditioner, transient suppressor or surge protector.

■ CD-ROM

To prevent the CD-ROMs from accidental damages:

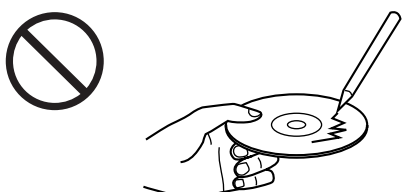
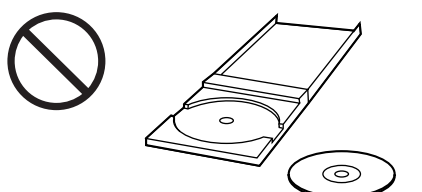
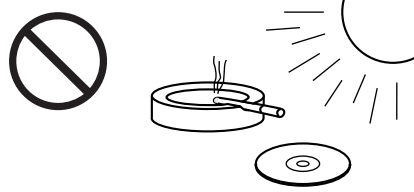
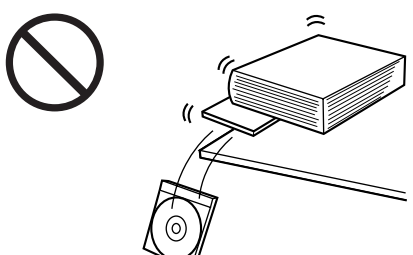
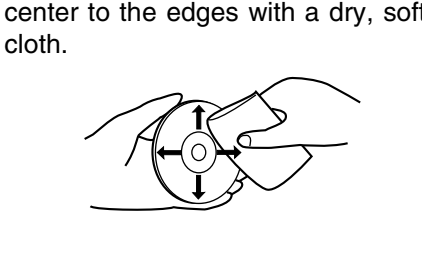
<p>Do not touch or write on the surface of the disc.</p>  <p>The illustration shows a hand holding a CD-ROM. A pen is touching the surface of the disc, with a jagged line indicating damage. A prohibition sign is in the top left corner.</p>	<p>Do not leave the disc out of its protective case.</p>  <p>The illustration shows an open CD-ROM case with the disc removed and lying on the surface next to it. A prohibition sign is in the top left corner.</p>	<p>Do not leave the disc in direct sunlight or near heat sources.</p>  <p>The illustration shows a CD-ROM lying on a surface next to a lit cigarette in an ashtray. A sun is shown in the background, representing heat sources. A prohibition sign is in the top left corner.</p>
<p>Do not place heavy objects on the disc case or drop the case.</p>  <p>The illustration shows a stack of books placed on top of a CD-ROM case. A prohibition sign is in the top left corner.</p>	<p>To clean the disc, hold the disc by its edges and wipe it from the center to the edges with a dry, soft cloth.</p>  <p>The illustration shows a hand holding a CD-ROM by its edges. A cloth is being used to wipe the disc from the center towards the edges. Arrows indicate the direction of the wipe.</p>	

Component Identification

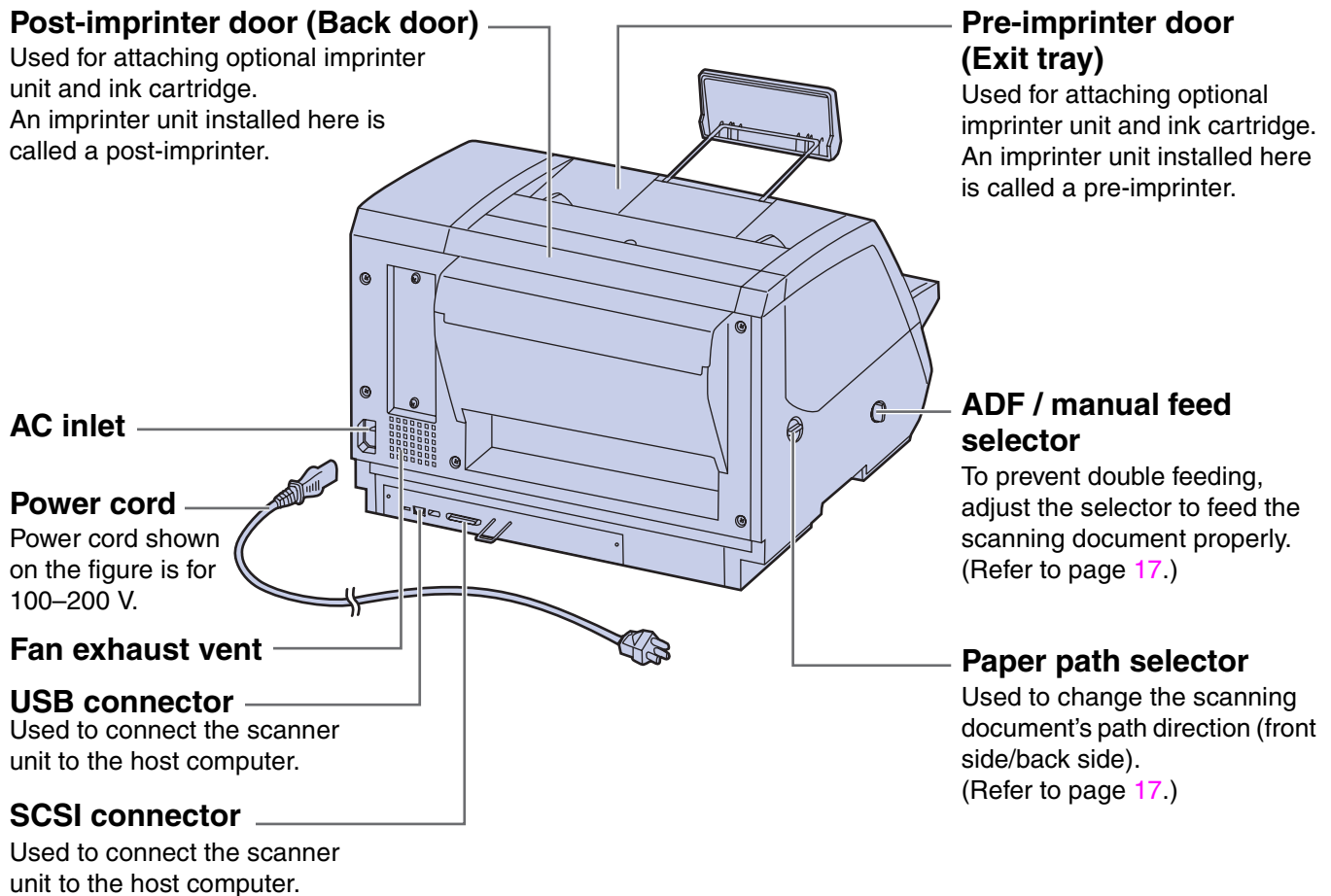
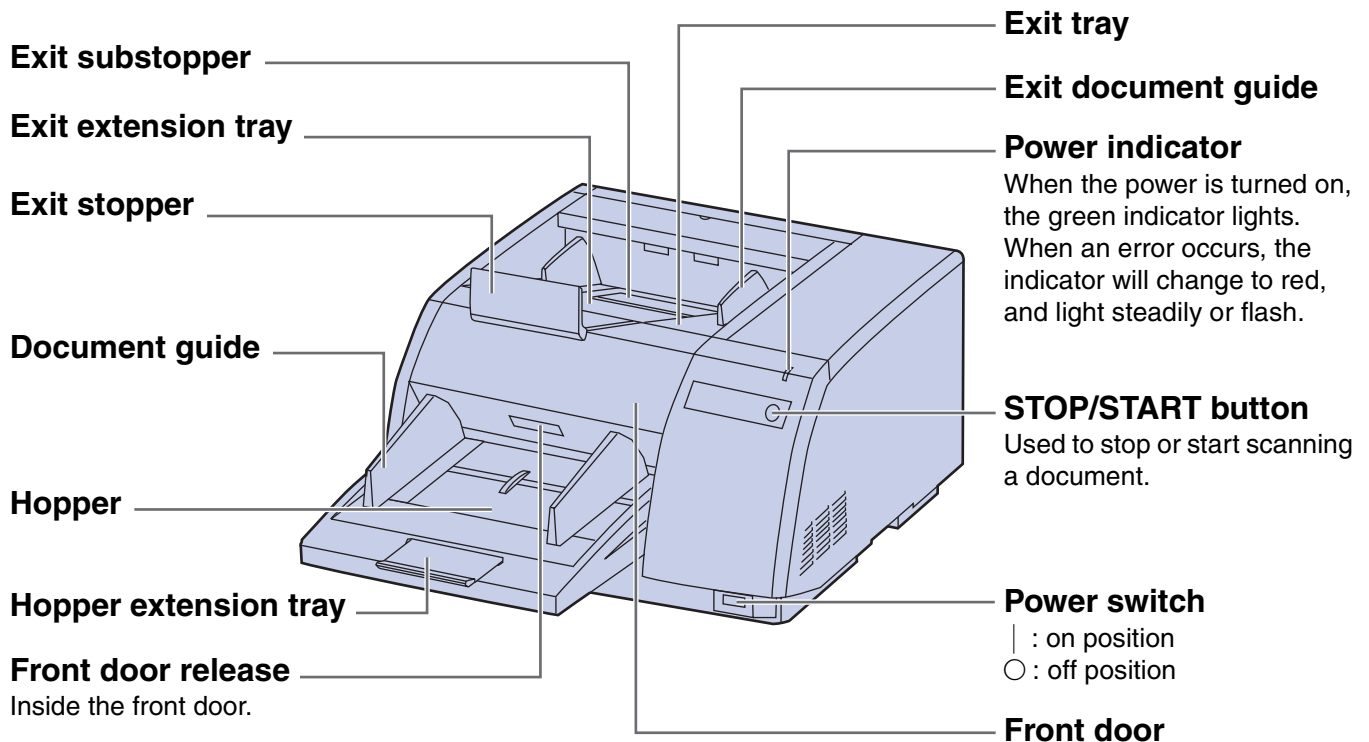

■ Power turn-on sequence

- 1** Turn on the power of the scanner.
 - The LED will now light.

- 2** Turn on the power of the host computer after scanner's LED stays green.
 - In case of the USB connection, the host computer recognizes the scanner automatically when the scanner is powered on even after the host computer is powered on.

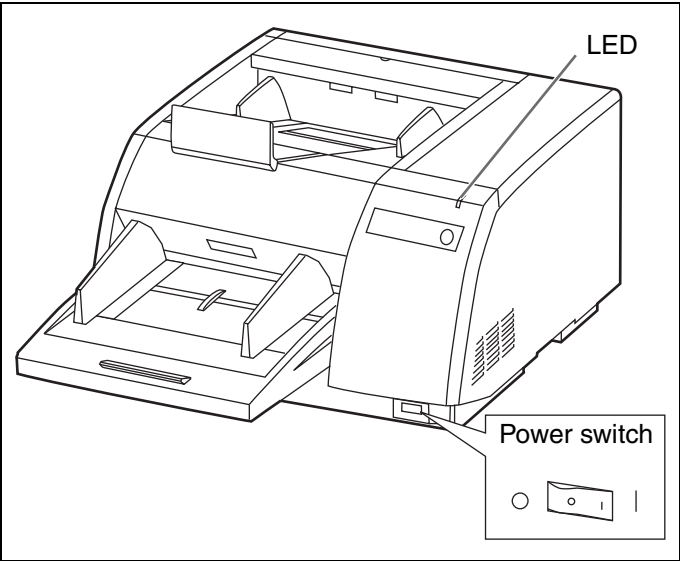

■ About LED

LED indicates the status of the scanner as follows:

LED light	Status
Green	Ready to scan or scanning
Green (flashing)	Sleep mode
Orange	Ready to scan or scanning with warning *1
Orange (flashing)	Initializing Sleeping with warning *1
Red	An error occurred *2

*1: The rollers need to be cleaned or replaced.
Refer to Maintenance Manual or Operating Instructions (CD-ROM) for the way of cleaning or replacing the rollers.

*1, *2: Check the status of the scanner using the User Utility.
The User Utility is included in the CD-ROM.

Component Identification

■ About the SCSI setting (Not required for USB connection)

When connecting the scanner to a SCSI chain using a SCSI cable, perform the SCSI ID setting correctly. The scanner is provided with a DIP switch for the SCSI ID No. setting.

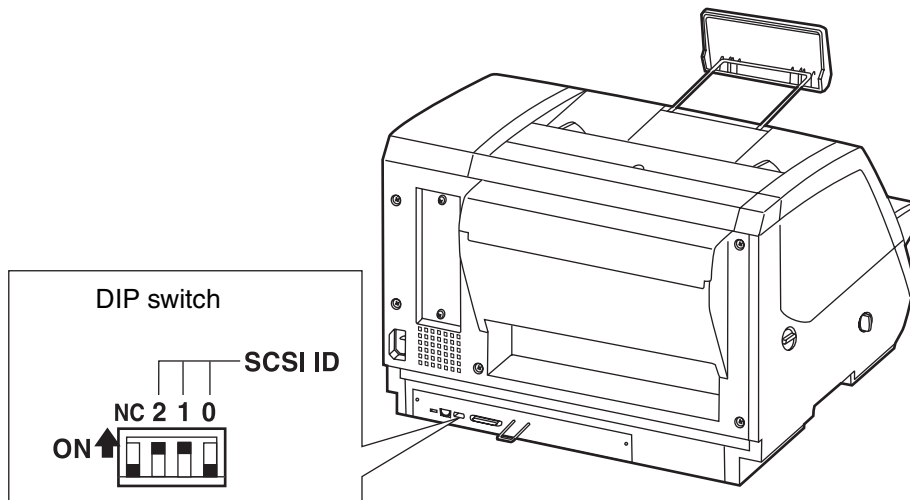

SCSI ID Setting

ID No.	Switch			Remarks
	#2	#1	#0	
0	OFF	OFF	OFF	
1	OFF	OFF	ON	
2	OFF	ON	OFF	
3	OFF	ON	ON	
4	ON	OFF	OFF	
5	ON	OFF	ON	
6	ON	ON	OFF	Default setting
7	ON	ON	ON	

Loading Documents

Acceptable documents

Document size:

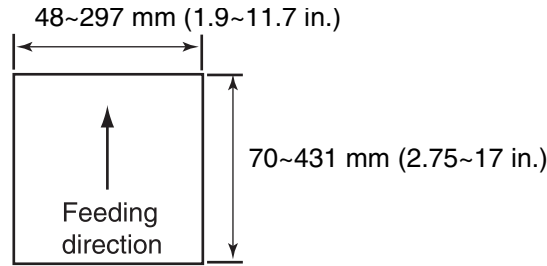

Paper thickness: Continuous paper feeding 40~157 g/m²
 Single paper feeding 20~157 g/m²
 Document smaller than A7 size 157 g/m² (42 lbs.) only

Maximum number of sheets loadable on the hopper tray:

g/m ²		40	52	64	75	80	90	104	157
lb.		11	14	17	20	21	24	28	42
Max. number of sheets	Width less than A4 short edge	350	320	300	250	240	210	180	120
	Width between A4–A3 short edge	240	220	200	160	160	140	120	80

- Each number of sheets indicates a guideline for fresh paper.
- The number of sheets depends on the paper quality. If a paper feed problem occurs, reduce the number of sheets of the document loaded on the hopper.
- The height of the document should not exceed the limit mark on the document guide.

Recommendable paper: Plain paper

The following types of documents may not be scanned properly.

- Broken or notched documents
- Curled, wrinkled or folded documents

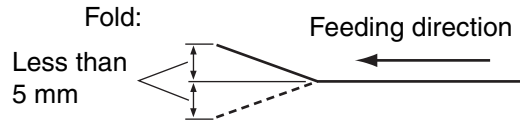
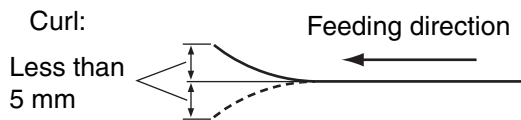

- Perforated or punched documents
- Not rectangular or irregularly shaped documents
- Tracing paper
- Thermal paper

When scanning is not performed properly, try the following methods:

- Set the feed speed to “Slow”.
- Scan the documents by manual feeding.
- Set the paper path selector to straight.

The following types of documents may cause frequent jams and double feeding.

- Extremely smooth or shiny paper or paper that is highly textured
- Paper with carbon
- Carbonless paper

If a paper jam or double feeding occurs, clean the rollers.

When a jam occurs at the document feeder, reduce the number of sheets loaded on the hopper to about 20.

Types of documents to avoid

- OHP sheets, other plastic films, cloths, or metallic sheets.
- Paper with irregularities such as tabs, staples, paste, etc.
- Documents with wet ink
- Thick or irregular documents such as envelopes, documents that are glued together, etc.

Be sure to remove the document from the exit tray after it is scanned.

When scanning different size documents, scanned sheets may need to be reordered for optimum performance.

Thick, thin or important document should be scanned by fed manually one sheet at a time.

Loading Documents

■ When scanning multiple sheets

Cautions:

- Please remove any staples from the document before scanning.
- Curled documents may cause a paper jam or damaging the unit, so please set the document flat before scanning.
- When scanning very important documents, confirm if the number of scanned images matches the number of actual pages.

1 Documents that have been stapled together or stacked together (as in a file folder) will need to be separated.

- ① Fan the stack of documents to separate all the edges.
- ② Hold both ends and bend the documents as shown in the illustration.
- ③ To flatten the documents, hold firmly and pull them apart as shown in the illustration.

Repeat these steps as necessary.

Prior to scanning, remove, all staples and paper clips from pages.

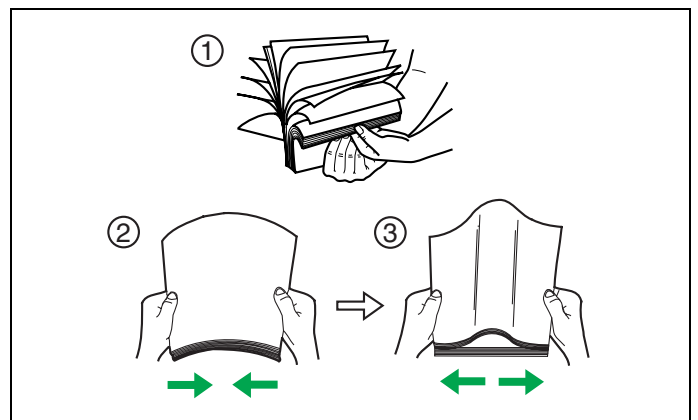
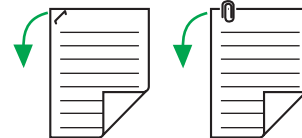

2 Carefully align the documents.

3 Adjust the document guides slightly larger than the actual size of the documents.

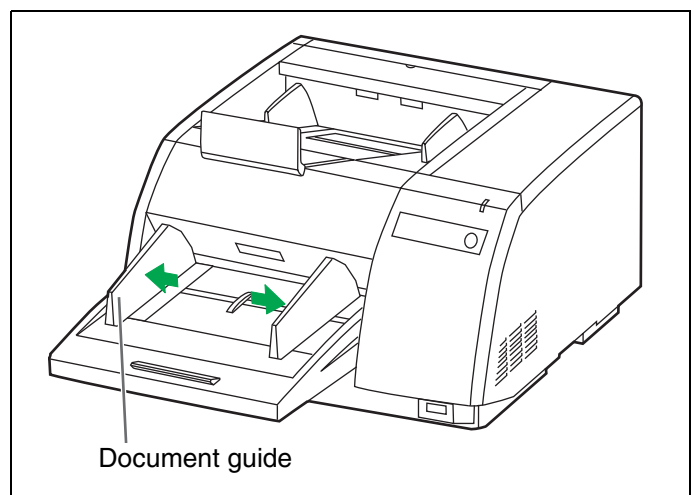

4 Place the documents on the hopper with the side to be scanned facing up. Then push them in the direction of the arrow until they stop.

- Be sure to place the documents on the hopper as shown in the diagram at the right.

The amount of documents should not exceed the limit mark on the document guide. This may cause a paper jam or skew.

- The scanning document size is different for the KV-S3065CL and KV-S3065CW. Please refer to [page 34](#) “Specifications” for details.
- For documents up to A4, letter or legal size, up to 300 sheets of 64 g/m² (17 lbs.) paper can be placed at one time on the hopper. For documents up to B4, A3 or ledger size, up to 200 sheets of 64 g/m² (17 lbs.) paper can be placed.

- Even with A4, letter and legal size documents, the maximum number of sheets of paper which can be inserted when the documents are to be scanned in the landscape mode is 200 which is the same number as for the B4, A3 and ledger size documents. (This is the number of sheets that comes up to the B4-A3 limit mark.)
- Depending on the types of paper, the document may slip and not be fed smoothly. In such case, reduce the number of sheets of the document.

5 Adjust the document guides to the size of the document to be scanned. Adjust the exit document guides to the size of the document to be output, if required.

Portrait

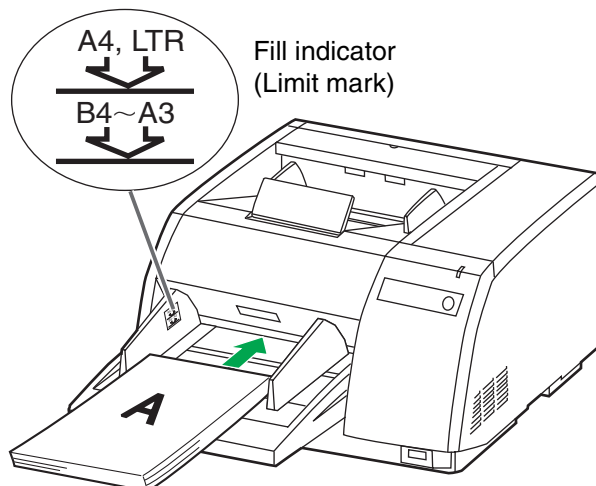

The fill indicator illustration is only for the KV-S3065CW.

Landscape

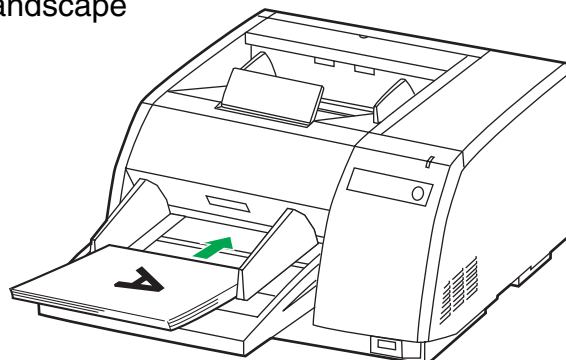

Exit document guides

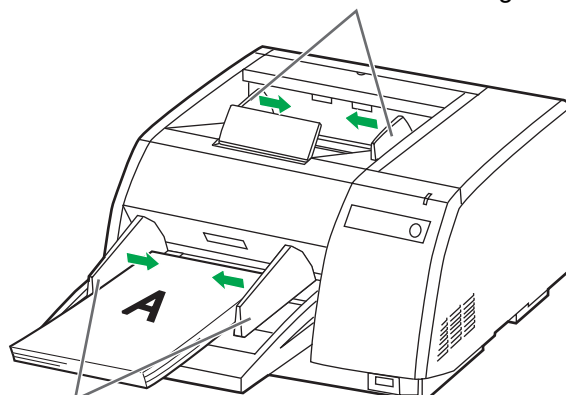

Document guides

Loading Documents

- 6** When using long paper, pull out the hopper extension tray from the hopper and the exit stopper from the exit extension tray. You can also extend the exit extension tray, if required. (See fig. 1)

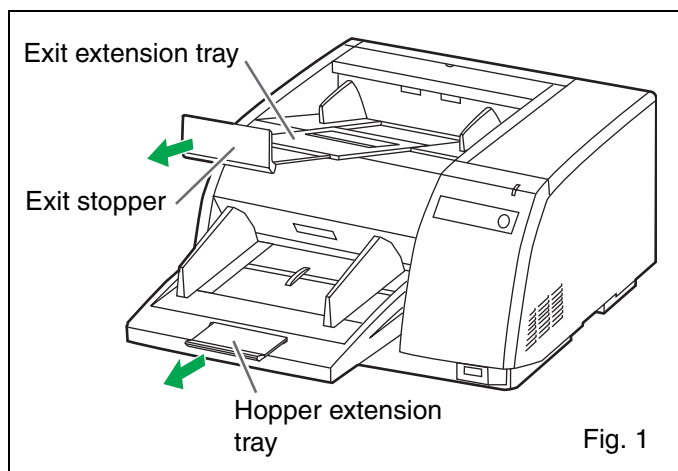

- When scanning narrow documents as shown below, pull up the exit substopper. (See fig. 2)

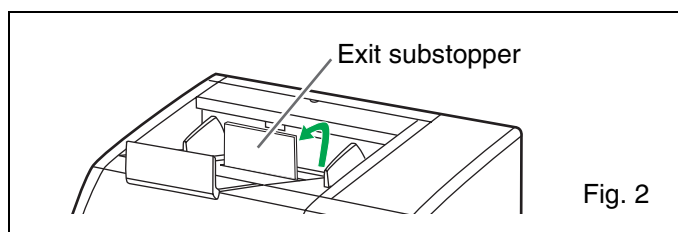
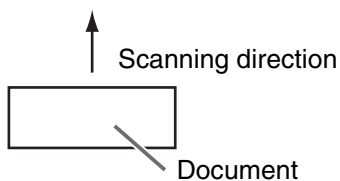

- Thin paper document may curl and not be stacked correctly. When scanning thin documents, raise the exit substopper slightly to let the document exit smoothly. (See fig. 3)

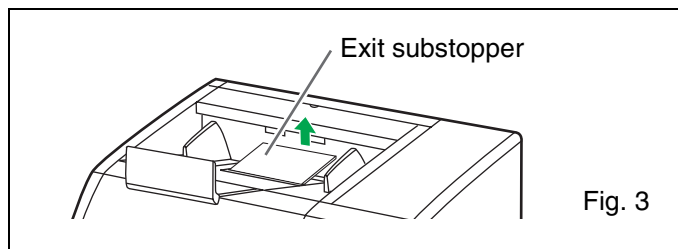

Paper Feed Settings

■ Selecting the paper path for scanned document

To select a U-turn path pass through to the front, set the paper path selector to the upper side.

To select a straight path pass through to the back, set the paper path selector to the lower side.

- When scanning documents with a thickness of 0.2 mm to 1 mm, like folded documents, set the paper path selector to straight path.

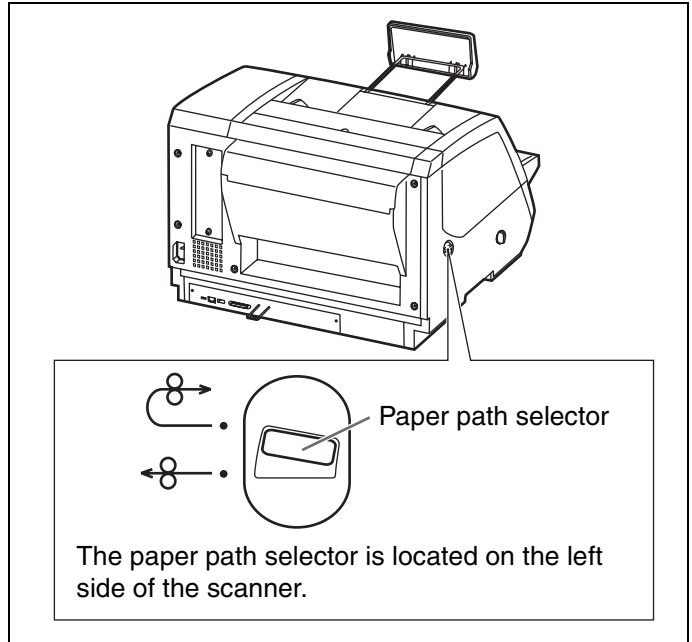

■ Setting the ADF / manual feed selector

● Single scanning

When scanning a single sheet or several sheets, set the ADF / manual feed selector to "MANUAL".

● Continuous scanning

Setting Position	Status
1	When double feeding occurs frequently or scanning a document with a rough face as in NCR paper
2 (Standard setting)	When scanning normal paper
3	When scanning with smooth sided paper or a paper jam occurs with normal paper
4	When a jam occurs at the paper feed component

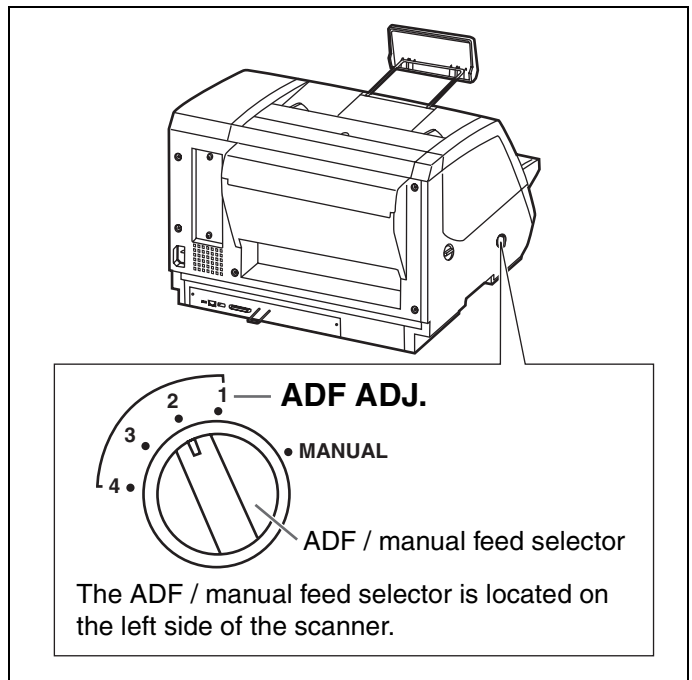

- The ADF / manual feed selector must be set in the correct position for this setting to function properly.
- If double feed alarm beeps frequently, change the ADF / manual feed selector.

- If thin paper (with paper weight less than 50 g/m²) causes a paper jam frequently at the paper feed component, the optional roller exchange kit for thin paper (KV-SS018) should be used.

Others

■ How to use the control sheet and separation sheet

If the control sheet is used, the documents under the control sheet are scanned in accordance with the code on the control sheet regardless of scanning condition that is selected previously.

- Multiple control sheets can be used.
- When using a control sheet, the application software required depends on the control sheet.
- Print out control sheets from the provided CD-ROM.

Cautions:

- Use the same size control sheet as the scanning document.
- When printing the control sheet, if the pattern falls in the area from the top side of the document to 25 mm, adjust the printer.
Also, copy the control sheet so that the pattern lies in the center of the copy.
- Be careful not to get the control sheet dirty.
Do not fold or crease the control sheet.
Scanning will not be performed properly.
- For details on control sheet and separation sheet, refer to section 3.35 Detect Control Sheet and section 3.36 Detect File Separation Sheet in the PIE Reference Manual.
- Control sheet functions:
 - Simplex
 - Duplex
 - Binary
 - Dither
 - Error diffusion
 - Dynamic Threshold
 - 256 level gray
 - Color
 - Function #1-#9

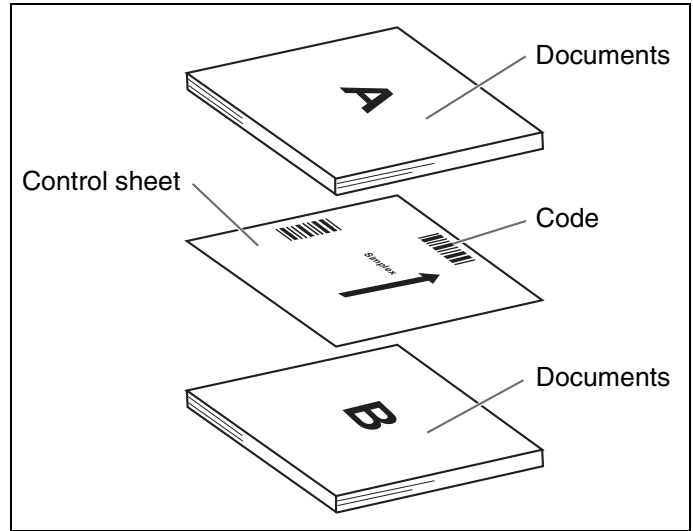

Changing the Reference Plate Setting

You can choose a background color to be scanned from white (black) to black (white). The scanner comes from factory set to black. The reference plate (B) and reference plate (F) setting must be changed simultaneously.

■ Reference plate setting

- 1** Turn the power off.
- 2** Use your hand to pull the front door release towards you (①). Then open the front door completely (②).

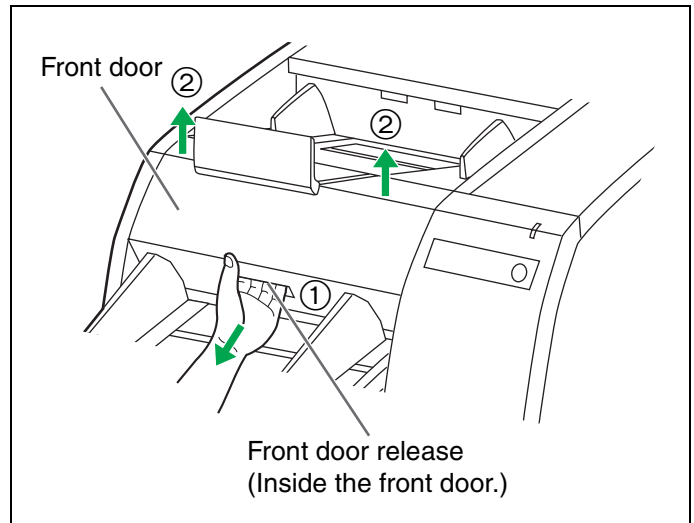

- 3** ① Using your finger, move the reference plate lever (B).
- ② Using your finger, move the reference plate lever (F).

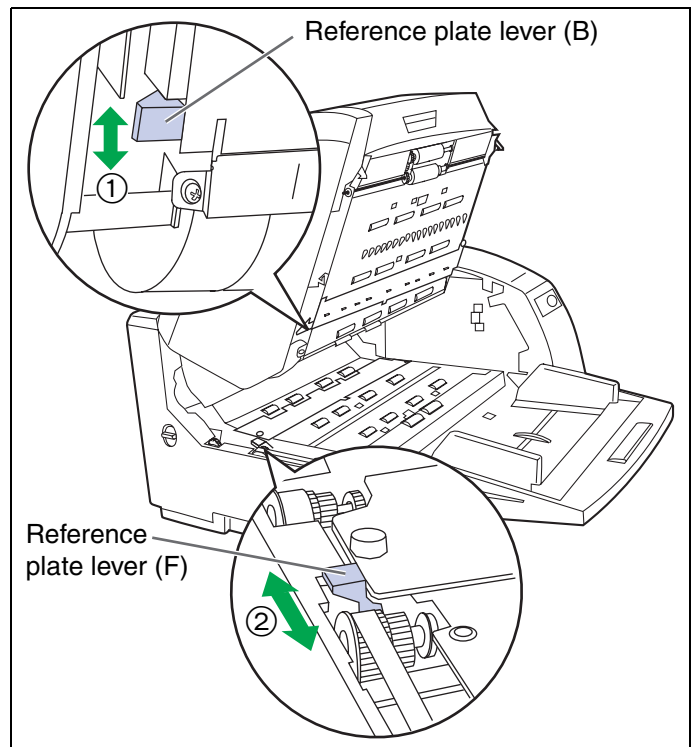
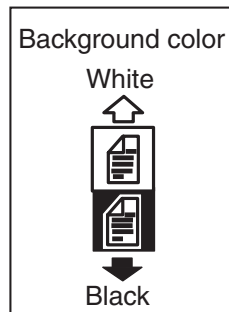

Changing the Reference Plate Setting

- 4** Close the front door.
- Push both sides of the front door down slowly until it clicks into place.

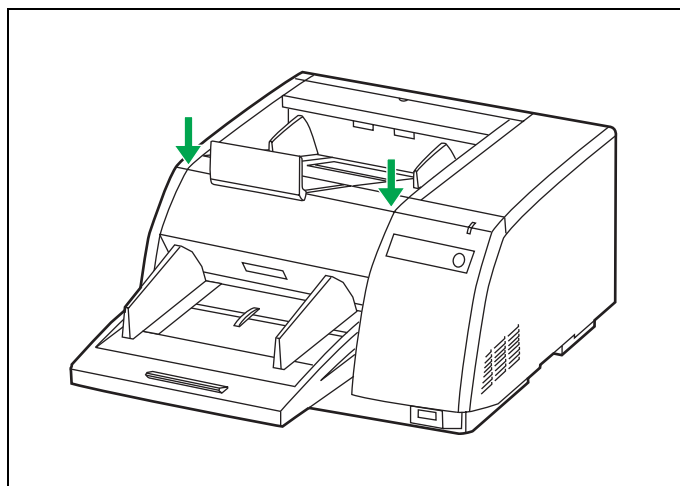

Clearing Paper Jams

Torn documents, thin documents or documents that are creased on the top edge may cause paper jams. If a paper jam occurs, remove the jammed sheet according to the following procedure.

■ Removing paper jams from the scanner

Use your hand to pull the front door release towards you (①), open the front door (②) and pull the jammed document towards the front.

Then close the front door.

- Push both sides of the front door down slowly until it clicks into place.

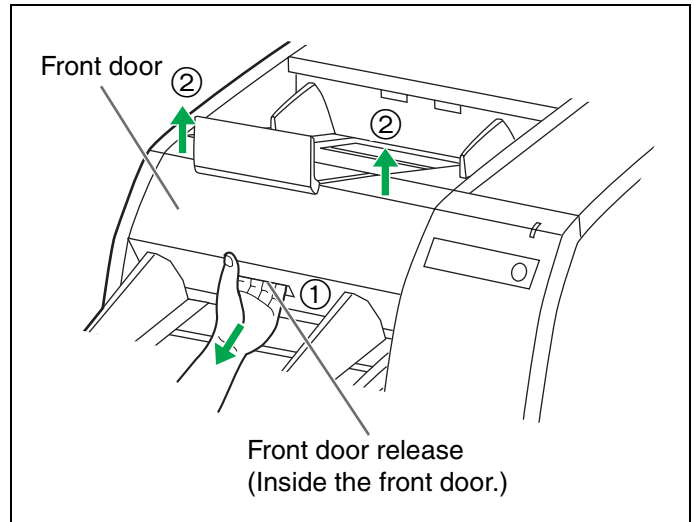

■ Removing paper jams from the exit path

If a jammed document appears at the exit path, open the front door and pull the document forward, then close the front door.

- Push both sides of the front door down slowly until it clicks into place.

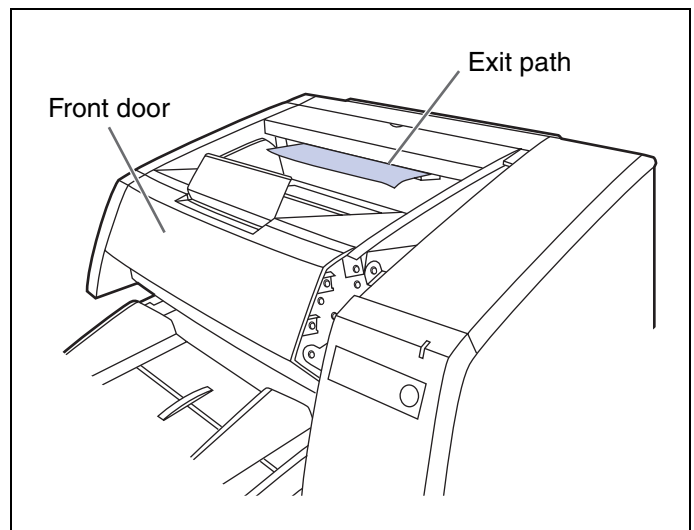

Cleaning the Unit

■ Outside of the scanner

- Clean the unit at least once a month.

- 1** Turn the power off.
- 2** Clean the cover with a soft cloth.
 - The document insertion and exit slots get dirty easily. Make sure to clean them.
- 3** Remove dirt and dust from the fan exhaust vent with a brush.

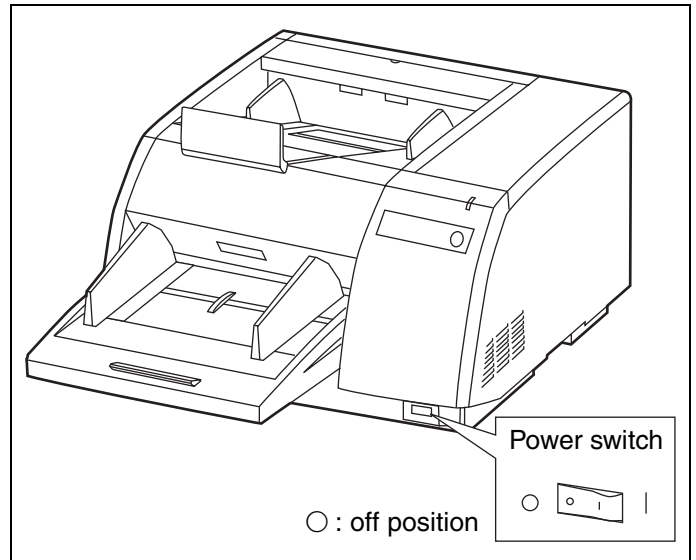

■ Inside the scanner

- Clean the unit at least once a week or when 20,000 sheets have been scanned, whichever comes first.
- Clean the rollers, sensors and double feed detectors if paper jamming or double feeding occurs frequently. (Refer to [pages 23–26](#).)
- Clean the image sensor covers when black or white lines appear on the scanned images. (Refer to [page 26](#).)
- If the documents you are scanning are dirty, then the scanner parts will become dirty as well. To maintain proper scanning, clean the scanner parts frequently.
- The image sensor covers may be very hot after scanning a lot of documents continuously. Never touch the image sensor covers or surroundings directly.

■ Roller cleaning paper

Open the bag on the dotted line and take out the roller cleaning paper.

- If the bag is left open for a long period of time, the alcohol will evaporate. Please use the roller cleaning paper immediately after opening the bag.

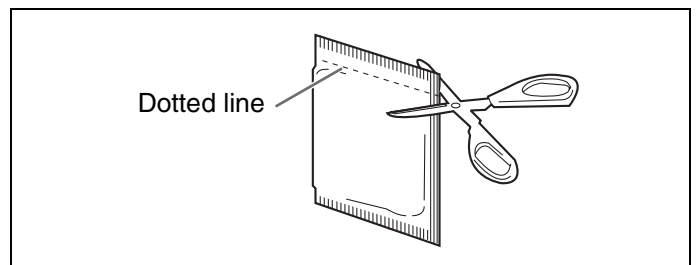

- ※ The roller cleaning paper (Model No. KV-SS03) is available from the dealer where you purchased your scanner.
For supplies and accessories: Call 1-800-346-4768 (U. S. A. only) or your dealer.

■ Cleaning the rollers

- 1** Turn the power off.
- 2** Use your hand to pull the front door release towards you (①). Then open the front door completely (②).

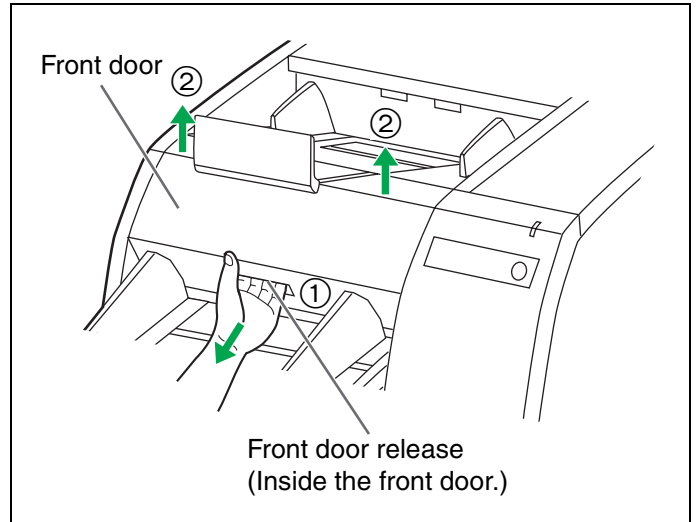

Cleaning the Unit

3 Use the roller cleaning paper (KV-SS03) to remove the dirt from the surfaces of all rollers.

- When wiping off the dirt, hold the rollers to prevent them from rotating. Wipe the rollers all the way around from one end to the other in the directions of the arrows shown on the diagram to the right.
- Perform the retard roller cleaning only in the left direction. If cleaned in the right direction, the roller may slip out of the proper position.
- When cleaning the rollers in the back of the bottom image sensor cover (rollers of part ①), do not touch the tip of the plastic pointer (black) in the back of the unit. Set the paper path selector as shown below.

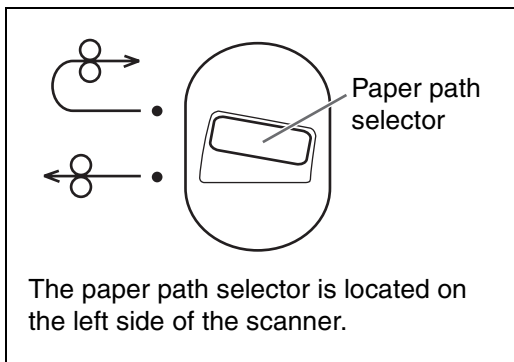

Warning:

When the tip of the pointer is raised, the tip may cause an injury.

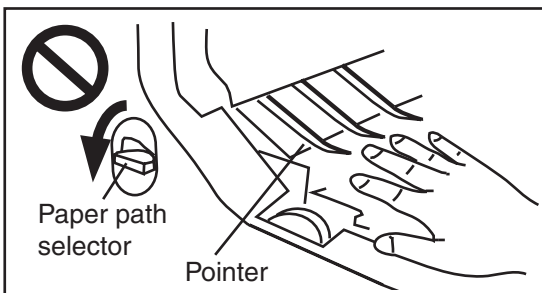

- The image sensor covers may be very hot after scanning a lot of documents. Never touch the image sensor covers or surroundings directly.

For roller cleaning, pull the belt in the direction of the arrow to rotate the rollers.

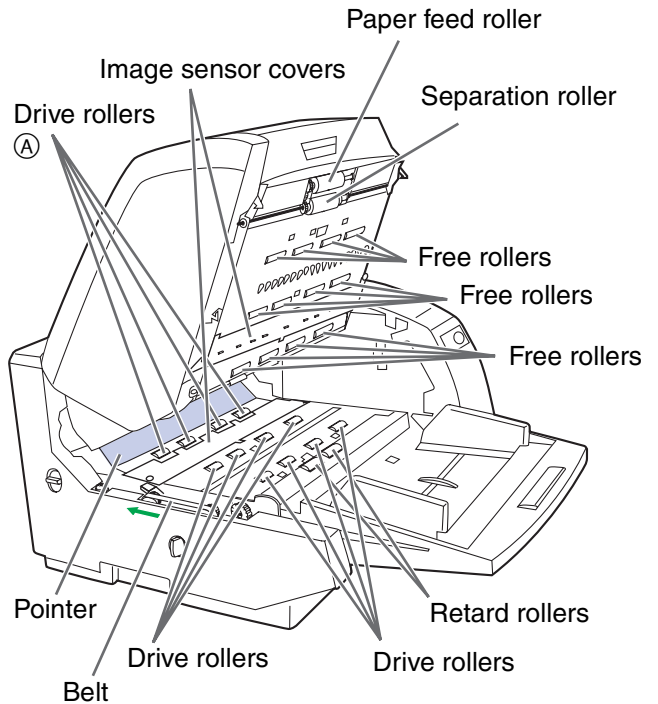

Conveyor rollers

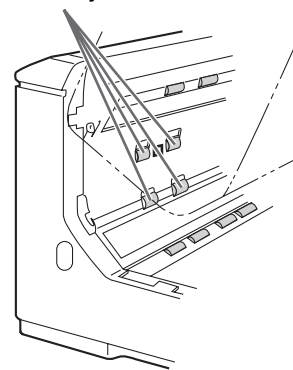

Left side view

Free rollers

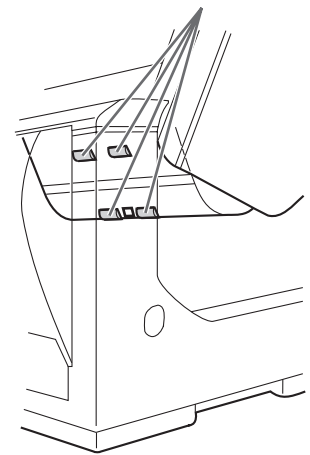

- Wipe in the direction of the arrows.

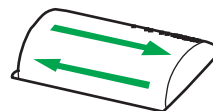

Other rollers

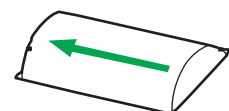

Retard rollers

- 4** Close the front door.
- Push both sides of the front door down slowly until it clicks into place.

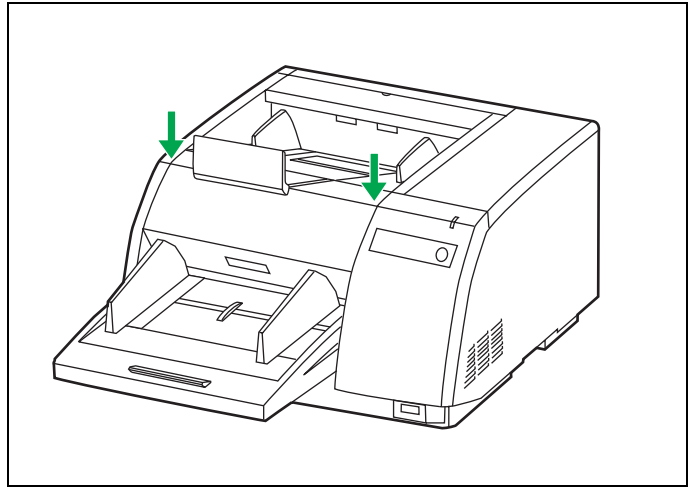

- 5** Clear the roller cleaning counter with User Utility.
- Click [Clear Counter] button for [After Clean Roller] with User Utility.

■ Cleaning the sensors, reflectors, double feed detectors and image sensor covers

- 1** Turn the power off.

- 2** Use your hand to pull the front door release towards you (①). Then open the front door completely (②).

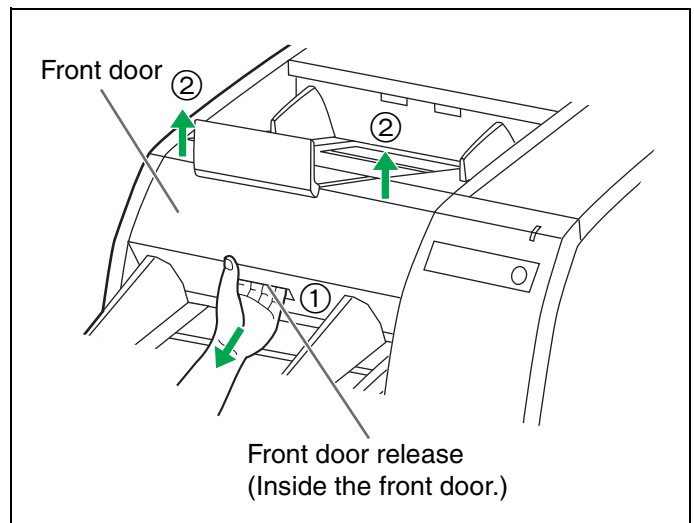

Cleaning the Unit

- 3** Clean the image sensor cover with the roller cleaning paper. Then remove the dirt on the sensors, reflectors and double feed detectors with the included blower.

- When cleaning the bottom image sensor cover, do not touch the tip of the plastic pointer (black) in the back of the unit. If the paper path selector is set to the lower side, it may cause an injury.

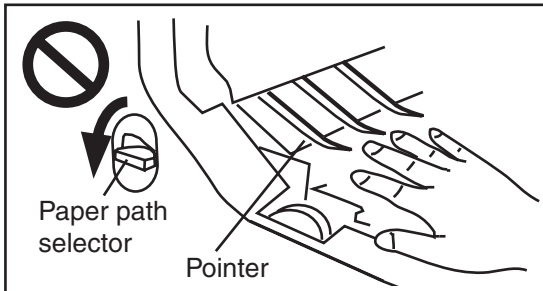

- The image sensor covers may be very hot after scanning a lot of documents. Never touch the image sensor covers or surroundings directly.

- 4** Close the front door.

- Push both sides of the front door down slowly until it clicks into place.

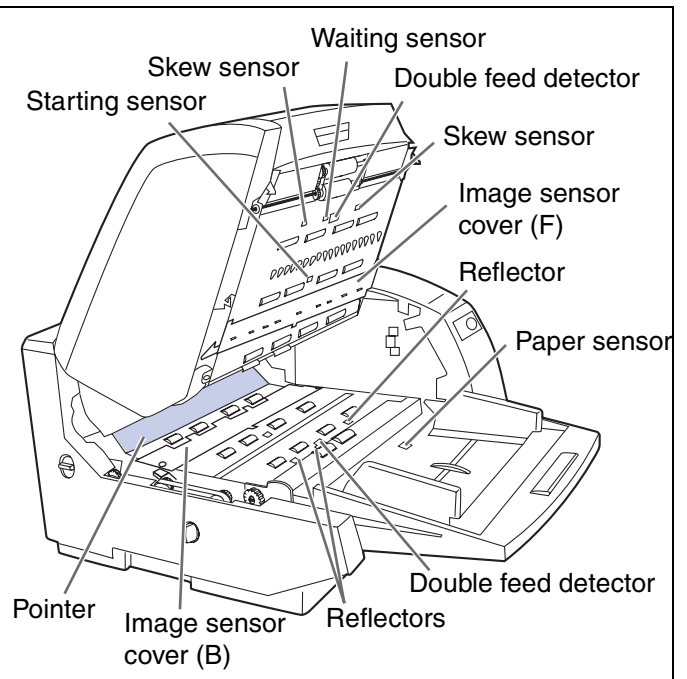

Left side view

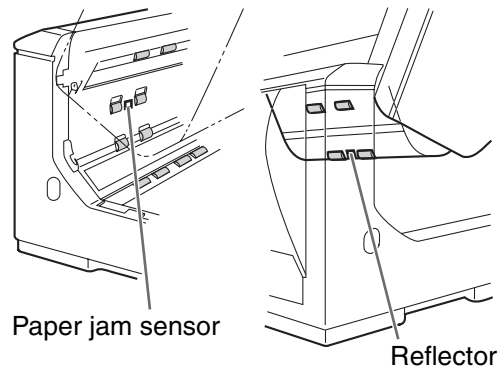

• How to clean the sensors, reflectors and double feed detectors

Remove the brush from the accessory blower and blow off the dirt with the blower.

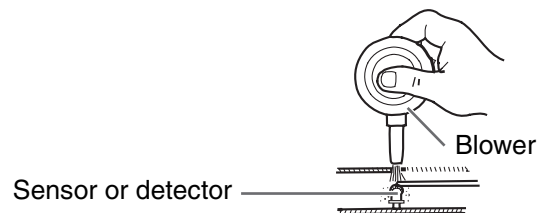

Replacing Consumables

■ Replacing paper feed roller module

- 1 Turn the power off and unplug the power cord.

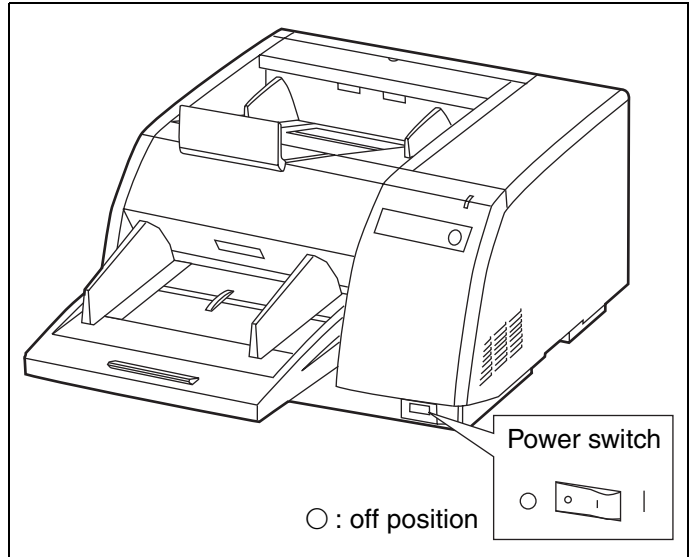

- 2 Use your hand to pull the front door release towards you (①). Then open the front door completely (②).

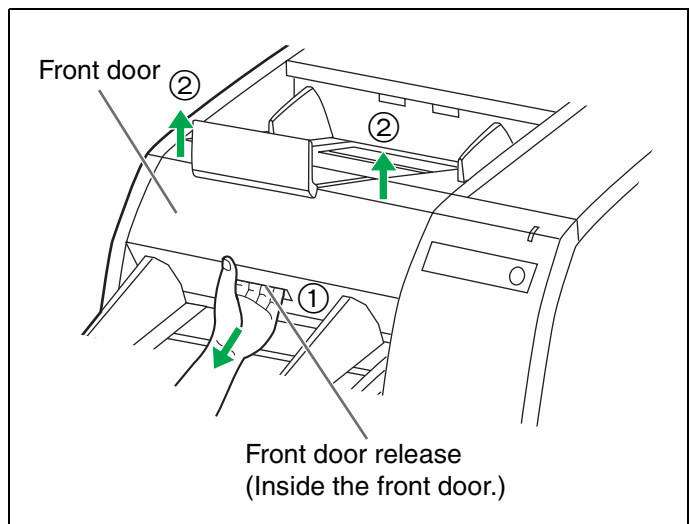

- 3 Place your finger on the paper feed roller block shaft and pull it towards you to remove the paper feed roller block from the magnet. (①)
Push down the green levers and remove the paper feed roller module from the scanner by holding the green levers. (②)

- The paper feed roller block is attached by a magnet.
- When moving the green levers, do not apply pressure in any other direction than the arrows. They may break.

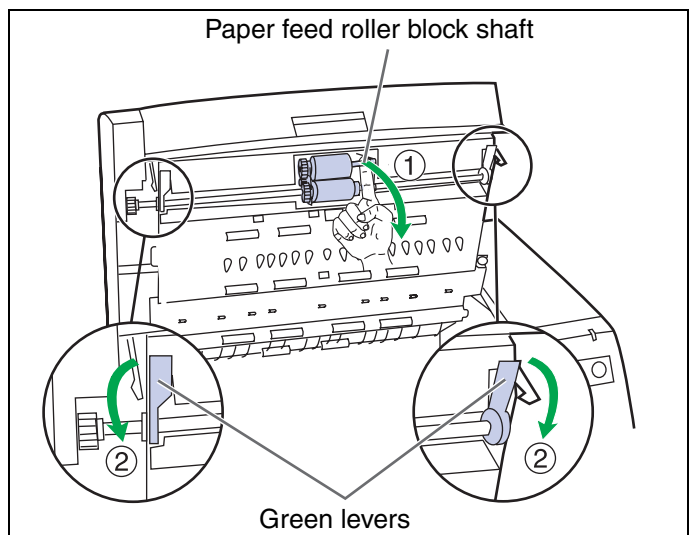

Replacing Consumables

4 Open the optional “Roller Exchange Kit (KV-SS017)”, and take out the new paper feed roller module.

5 Install the new paper feed roller module with the gear on the left side and the bearings into the guide grooves of the side chassis in the scanner. (①)

Then push up the green levers on both ends until they click into place. (②)

- Match the paper feed roller module with the bearings and guide grooves, and then attach it.

6 Push up on the paper feed roller block and it will magnetically attach to the chassis. (③)

- When attaching the paper feed roller block to the chassis, do not damage the roller.

Caution:

Do not close the front door when the paper feed roller block is not installed completely, or the paper feed roller may be damaged.

- To continue, replace the retard roller module according to the following procedure. (The retard roller module is located in the conveyor.)

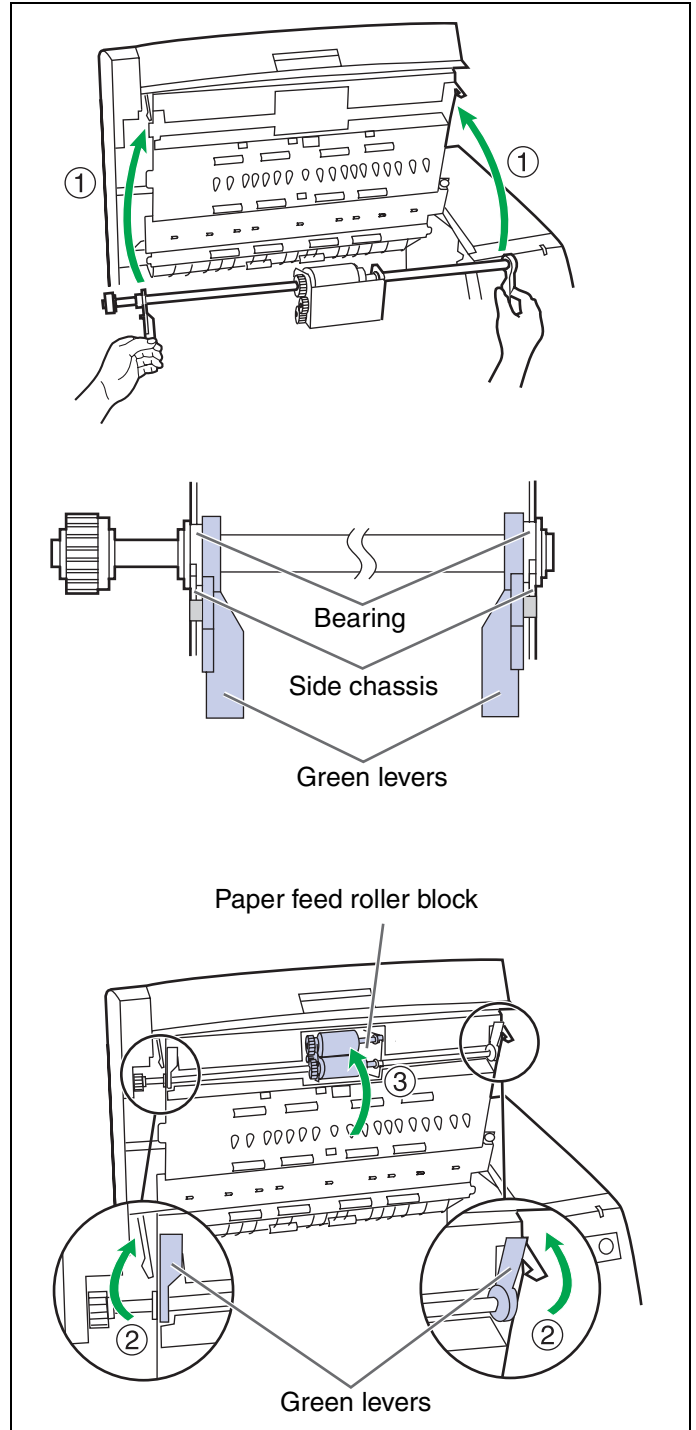

■ Replacing retard roller module

7 Pull open the conveyor towards you by using the indent on the right side.

- When the conveyor is pulled towards you, the click-stop mechanism will be released.

Caution:

When opening the conveyor, be careful not get your finger stuck in the indent.

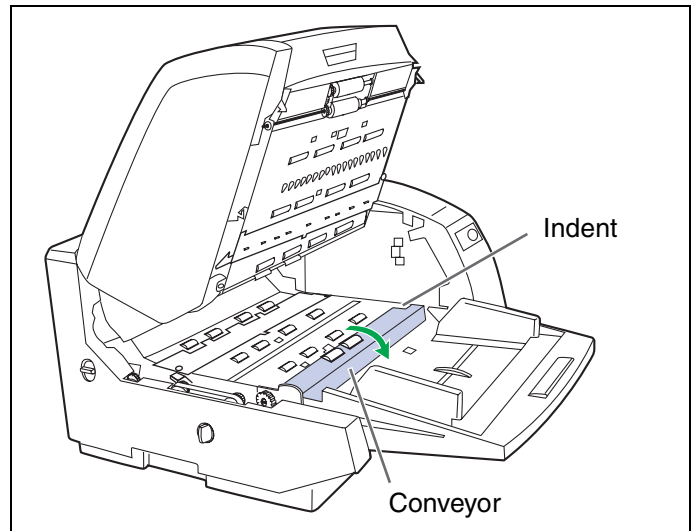

8 Pull the right side of the shaft in the direction of the arrow and hold it there. (1)

Pull the retard roller module in the direction of the arrow (2) and then remove it.

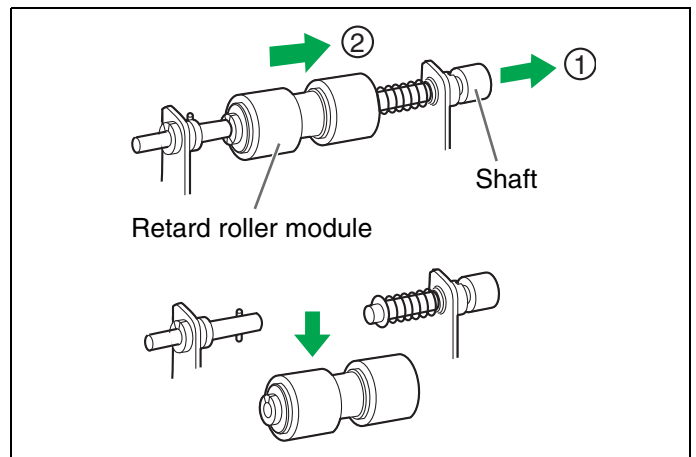

Replacing Consumables

9 Take out the new retard roller module in the optional “Roller Exchange Kit (KV-SS017)”.

10 Pull the right side of the shaft in the direction of the arrow and hold it there. (①)

Attach the new retard roller module as shown in the diagram on the right (②) and then return the right side of the shaft in the direction of the arrow. (③)

- Confirm if pin A and pin B are inserted in their notches correctly.
- Attach the retard roller module so that the notch A is on the left side.

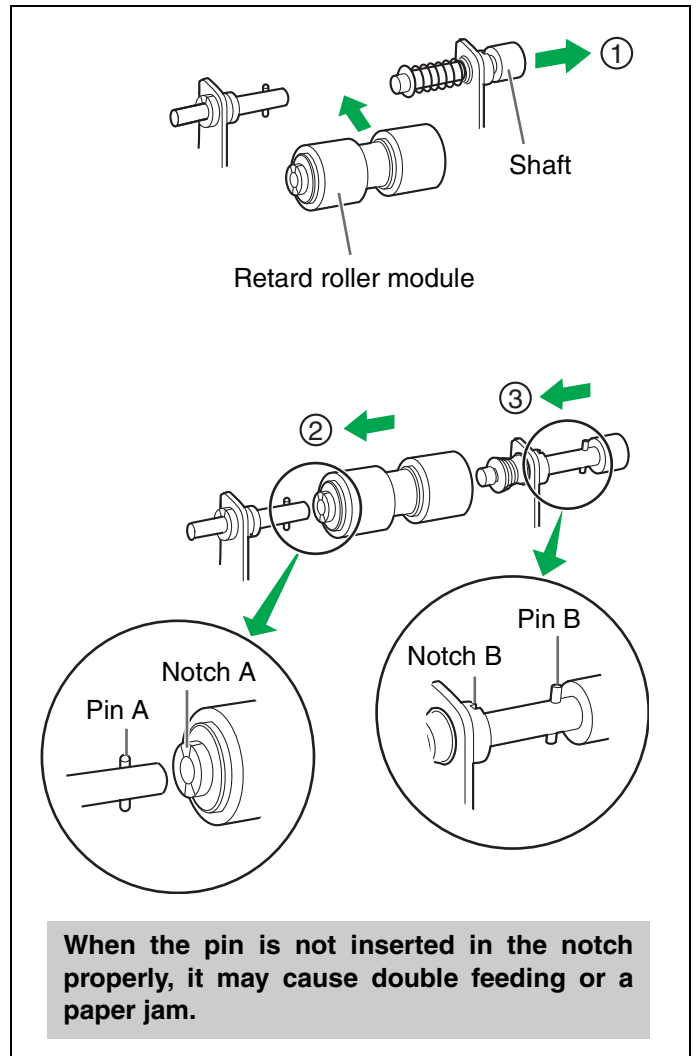

11 Hold the conveyor using both hands, and close the conveyor by pushing it into the unit.

- When the conveyor is closed, the click-stop mechanism will operate.

Caution:

If the conveyor is not closed correctly and the front door is closed, the conveyor may break.

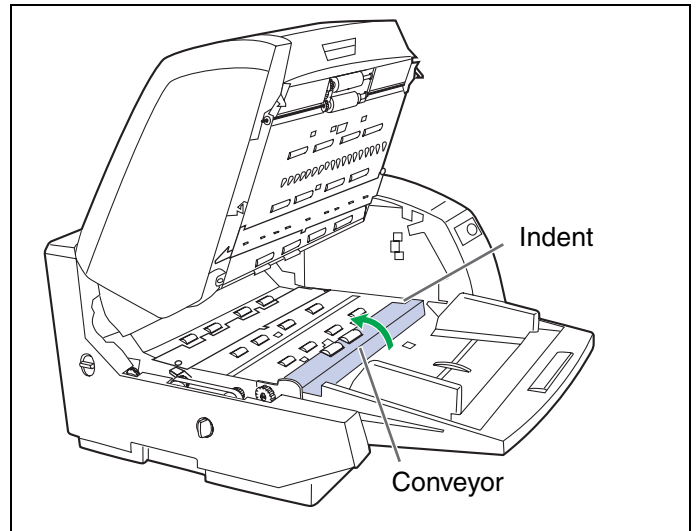

12 Close the front door.

- Push both sides of the front door down slowly until it clicks into place.

13 Clear the roller replacing counter with User Utility.

- Click [Clear Counter] button for [After Replace Roller] with User Utility.

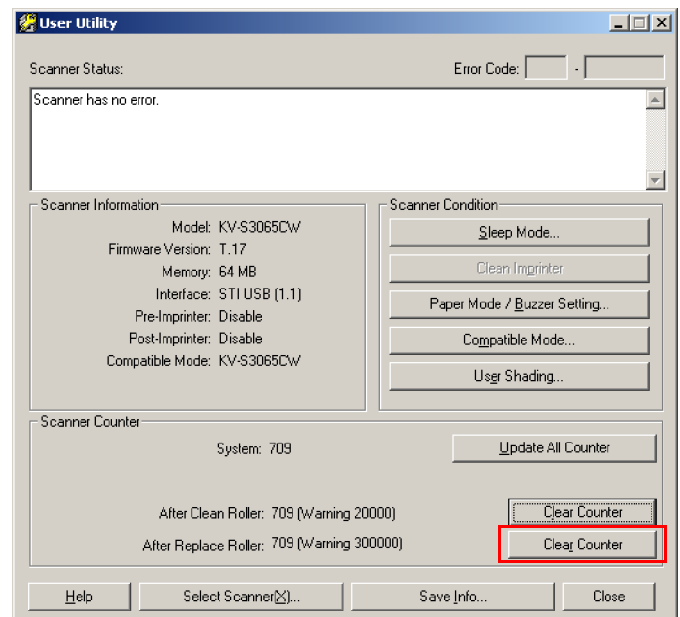

Shading Adjustment

● What is the purpose of the shading adjustment?

The process whereby the variations in the distribution of the lamp's light quantity are transformed into a fixed output within the scanning range is known as shading adjustment. It can be carried out by means of the User Utility using the special shading paper which is provided with this scanner.

● When shading adjustment is required

Proceed with the compensation when the colors in some parts of the scanned images differ in the extreme, or when the image quality fails to be improved even after the inside the scanner is cleaned.

● Before proceeding with the shading adjustment

Before proceeding, be absolutely sure to thoroughly clean the image sensor cover (F). Image sensor cover (B) as well as the transport path and drive rollers of the scanning unit.

If the shading adjustment is carried out while these parts are still dirty, it will not be possible to eliminate the lines that form on the scanned images.

● Shading adjustment procedure

1. Start the User Utility.
2. Click "User Shading" on the main menu, and operate as the image display dictates. For further details, refer to section 4.6 in the User Utility Reference Manual.

● Caution

If the scanned images are still lined after the shading adjustment has been performed and if these lines are not eliminated even after the image sensor cover areas have been cleaned, it means that the shading has not been compensated properly. Clean the parts again, and then proceed with the shading adjustment.

Repacking Instructions

It is highly recommended that you keep the original carton and ALL packing materials. If you need to transport or ship your scanner, please follow these instructions.

- Please use the original carton and all of the original packing materials.
- **Improper repacking of the scanner may result in a service charge to repair the unit.**
- The scanner should be handled in the correct (horizontal) position.

Materials Required :

- Original Scanner Carton & Packing Materials
- Shipping Tape and Scissors

- 1** Disconnect your scanner from the electrical outlet and the interface cable.
- 2** Fold the plastic part of the exit stopper and put the exit stopper into the exit extension tray. Slide the exit extension tray into the pre-imprinter door if it is pulled out.
- 3** Open the pre-imprinter door and tighten the screw.

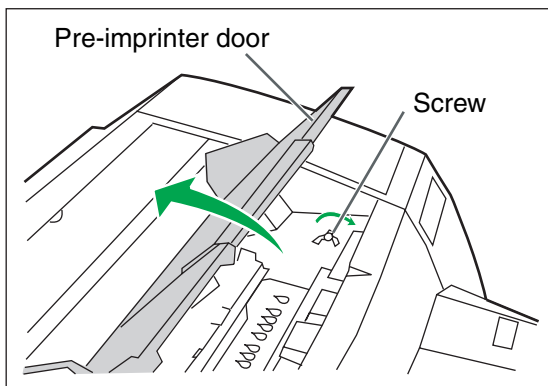

- 4** Pack the scanner.

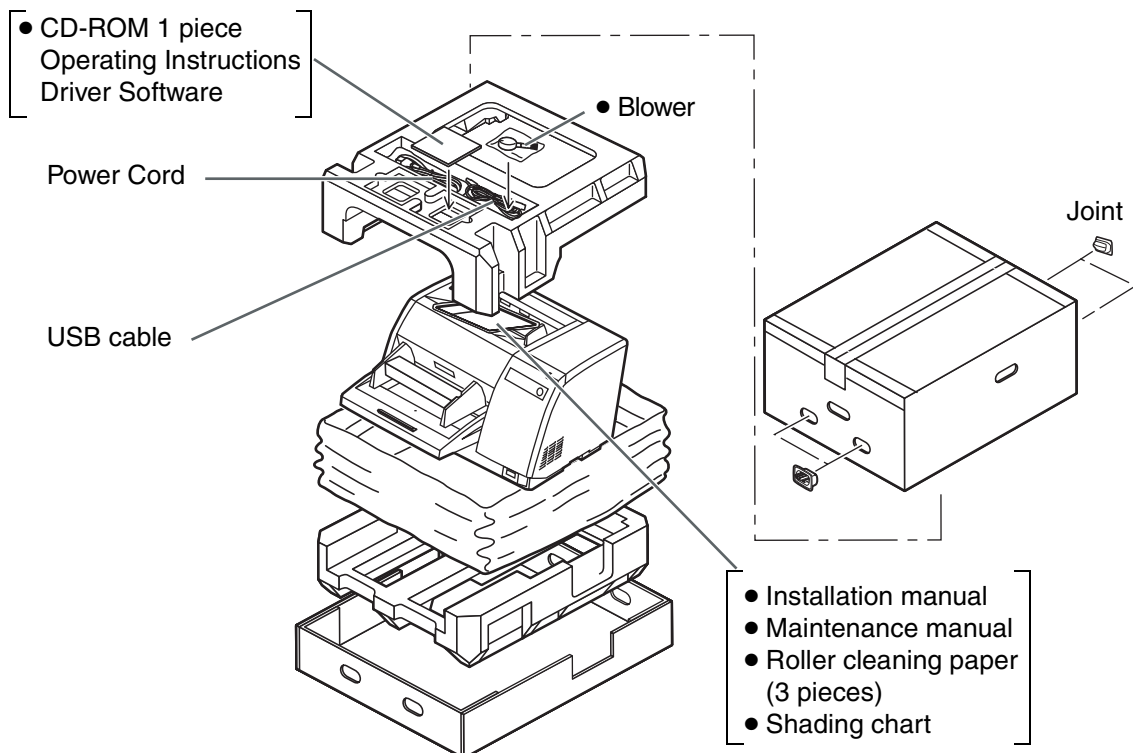

Specifications

Item		Model No.	KV-S3065CL	KV-S3065CW	
Scanner	Scanning face	Duplex scanning			
	Scanning method	Front side : CIS (Contact Type Color Image Sensor) Back side : CIS (Contact Type Color Image Sensor)			
	Scanning width	227 mm (8.9 in.)	302 mm (11.9 in.)		
	Readout speed	Simplex scanning : Approx. 65 sheets/min. (Letter, fed lengthwise, 200 dpi) Approx. 60 sheets/min. (A4, fed lengthwise, 200 dpi) Duplex scanning : Approx. 60 sheets/min. (Letter, fed lengthwise, 200 dpi) Approx. 55 sheets/min. (A4, fed lengthwise, 200 dpi)			
	Resolution	Main scanning direction : 100~600 dpi (1 dpi step) Sub-scanning direction : 100~600 dpi (1 dpi step) (Same as main scanning direction) The optical resolution is 600 dpi.			
	Tonal gradation	Binary mode, Grayscale mode (8 bit), 64-step gradation (dither) mode, Error diffusion mode			
	Image control	Image emphasis, Dynamic threshold, Automatic separation, Invert, White level from paper			
	Compression	MH (G3), MR, MMR (G4), JPEG			
	Paper	Size*	48×70 mm (1.9×2.75 in.) to 297×431 mm (11.7×17 in.)		
		Thickness	Single paper feeding : 0.025 to 0.2 mm (1.0 to 7.9 mils) Continuous paper feeding : 0.06 to 0.2 mm (2.4 to 7.9 mils) Note: 1 mil = 1/1000 in.		
Weight		Single paper feeding : 20 to 157 g/m ² (5.3 to 42 lbs.) Continuous paper feeding : 40 to 157 g/m ² (11 to 42 lbs.)** Smaller than A7 size : 157 g/m ² only			
Hopper capacity	Smaller than Letter/A4 portrait : 300 sheets (64 g/m ²) 17 lbs. Wider than Letter/A4 portrait : 200 sheets (64 g/m ²) 17 lbs.				
Unit	External dimensions (Width×Depth×Height)	495×575×288 mm (19.5×22.7×11.4 in.)			
	Mass (Weight)	24 kg (53 lbs.)			
	Power requirement	AC100–120 V, 50/60 Hz AC220–240 V, 50/60 Hz			
	Power consumption	Maximum (Scanning)	1.4 A (AC100–120 V) 0.6 A (AC220–240 V)		
		Minimum (Standby)	0.6 A (AC100–120 V) 0.3 A (AC220–240 V)		
Sleep mode		8 W (AC100–120 V) 8 W (AC220–240 V)			

“Weight in pounds” of paper represents the weight of 500 [17×22 inches (432×559 mm)] sheets.

* The scanning size depends on the memory installed in the scanner. Refer to PIE Reference Manual for details.

** For scanning thin paper (with paper weight less than 50 g/m²), the optional roller exchange kit for thin paper is recommended.

Model No.		KV-S3065CL	KV-S3065CW
Item			
Operating Environment	Operating temperature and humidity	15 °C to 30 °C (59 °F to 86 °F), 20% to 80% RH	
Storage Environment	Storage temperature and humidity	0 °C to 35 °C (32 °F to 95 °F), 10% to 80% RH	
Option	Roller exchange kit (KV-SS017) Roller exchange kit for thin paper (KV-SS018) Imprinter option (KV-SS014) Roller cleaning paper (KV-SS03) Ink cartridge (KV-SS021)		

Troubleshooting

If a problem occurs while the unit is being used, check the following items and check the scanner status with the User Utility. If the unit still malfunctions, turn it OFF, unplug the power cord and call for service.

Symptom	Possible Cause	Remedy	
The front door cannot be opened.	The screw is not loosened.	Open the pre-imprinter door and loosen the screw. (Refer to the Installation Manual on page 19.)	
The LED does not light when the power switch is turned ON.	The power cord is not plugged in.	Insert the power plug firmly.	
	Problem with power supply.	Disconnect the scanner from the electric outlet and call for service.	
The computer does not recognize the scanner.	The scanner is not connected to the computer correctly.	Connect the cables correctly.	
	The scanner is not registered correctly.	Uninstall the scanner from the computer. Register the scanner hardware again. (Refer to the Installation Manual on pages 25 and 26.)	
	SCSI connection	The computer cannot recognize the SCSI card.	Check your computer whether the SCSI card is installed correctly using the device manager's property. Refer to the Installation Manual on page 24.
		The same ID number is used for the scanner and the other device.	Use the different SCSI ID numbers for each devices. (See page 12 .)
		The scanner was turned on after the computer was turned on.	Turn the computer OFF. Turn the scanner ON, and then turn the computer ON again.
	USB connection	The USB interface of the computer is not installed correctly.	Check the computer whether the USB interface of your computer is installed correctly using the device manager's property.
		The scanner is connected via USB hub.	Do not connect via USB hub.
		The cable without High-Speed logo is used.	Use the cable with High-Speed logo.
	Scan speed is slow at USB connection.	The scanner is connected with USB 1.1.	Connect with USB 2.0.
The document has been loaded on the hopper tray. But the scanner does not start scanning.	The document is not loaded properly.	Load the document correctly. (See pages 13–16 .)	
	The sensor cannot detect the document as the edge of the document is curled.	Flatten the document and load it again.	

Symptom	Possible Cause	Remedy
Double feeding problems occurs frequently or the scanner stops loading while scanning.	The rollers are dirty.	Clean all of the rollers. (See page 23 .)
	The rollers have reached their life expectancy.	Replace the paper feed roller module and the retard roller module. (See page 27 and page 29 .)
	The document is curled or folded.	Flatten the document and load it again after reducing the pages.
	The irregular type document is to be scanned.	Make a copy of the document on specified paper (see page 13) and scan the copy.
	The document has a length of less than 70 mm (2.75 in.).	Make a copy of the document on paper of the specified size and scan the copy. (See page 13 .)
A paper jam occurs frequently.	The ADF/manual feed selector is not set in the correct position.	Set the ADF/manual feed selector correctly. (See page 17 .)
Scanned image is aslant.	The document guides are not adjusted to the size of the document to be scanned. The document to be scanned is set aslant on the hopper tray.	Adjust the document guides properly to the size of the document to be scanned.
	Right and left sides of the document to be scanned are not the same in height, because of curl and fold.	Remove curl and fold then reduce the amount of the document.
The scanned document is blank.	The document to be scanned was loaded face down (upside down).	Load the document correctly. (See page 15 .)
Vertical lines appear on the scanned document.	The image sensor covers are dirty.	Clean the image sensor covers (F and B). (See page 26 .)
The scanning density is uneven.	The image sensor covers are dirty.	Clean the image sensor covers (F and B). (See page 26 .)
	The quantity distribution of light varies.	Adjust shading. Please refer to section 4.6 of a user utility reference manual.
The color of the scanned document is extremely different from the original document.	The settings of the computer monitor is wrong.	Adjust the computer monitor settings.
Dark spots or noise appear on the scanned documents.	The image sensor covers are dirty.	Clean the image sensor covers. (See page 26 .)
Scanned image has moire fringes such as stripe or wavy pattern noise.	It is caused by printing pattern of the document and the congeniality of the scanning resolution.	Please use the moire reduction function or change the resolution and try to scan.

Index

	Page		Page
<hr/> A <hr/>		<hr/> F <hr/>	
AC inlet	10	Fan exhaust vent	10, 22
Acceptable documents	13	Free rollers	24
ADF / manual feed selector	10, 17	Front door	10, 19, 21, 23, 25, 27
		Front door release	10, 19, 21, 23, 25, 27
<hr/> B <hr/>		<hr/> G <hr/>	
Belt	24	Green levers	27, 28
Blower	26		
<hr/> C <hr/>		<hr/> H <hr/>	
CD-ROM	1, 9	Hopper	10
Cleaning the unit	22	Hopper extension tray	10, 16
Component identification	10	Hopper tray	13
Control sheet	18		
Conveyor	29, 31	<hr/> I <hr/>	
Conveyor rollers	24	Image sensor cover	22, 24, 26, 32
CPU	2	Imprinter option	35
		Indent	29, 31
<hr/> D <hr/>		Ink cartridge	35
DIP switch	12	Interface	2
Document guide	10, 13, 14		
Documents to avoid	13	<hr/> L <hr/>	
Double feed detector	26	Landscape	15
Drive rollers	24	LED	11, 36
		Limit mark	13, 15
<hr/> E <hr/>		Loading documents	13
Energy Star	2		
Exit document guide	10	<hr/> M <hr/>	
Exit extension tray	10, 16, 33	Memory	2
Exit path	21	Multiple sheets	14
Exit stopper	10, 16		
Exit substopper	10, 16	<hr/> N <hr/>	
Exit tray	10, 13	Notice	4

	Page
O	
Operating environment	35
Option	35
OS.	2

P	
Paper feed roller	24
Paper feed roller block shaft	27
Paper jam sensor	26
Paper jams	21
Paper path selector	10, 17, 24
Paper sensor	26
Pointer	24
Portrait	15
Post-imprinter door	10
Power cord	4, 10
Power indicator	10
Power switch	10, 11, 22, 27
Precautions	7
Pre-imprinter door	10

R	
Reference plate	19
Reference plate lever	19
Reflector	26
Repacking	33
Replacing consumables	27
Retard roller	24
Retard roller module	29, 30
Roller cleaning paper	4, 22, 35
Roller exchange kit	35

	Page
S	
SCSI connection	2
SCSI connector	10
SCSI ID setting	12
Separation roller	24
Separation sheet	18
Shading	32, 37
Skew sensor	26
Specifications	34
Starting sensor	26
STOP/START button	10
System requirements	2

T	
Troubleshooting	36

U	
USB connection	2, 11, 12
USB connector	10
USB hub	2, 36
User utility	11, 25, 32

W	
Waiting sensor	26

Panasonic Digital Document Company
A Unit of Matsushita Electric Corporation of America
Two Panasonic Way, Secaucus, New Jersey 07094

Panasonic Canada Inc.
5770 Ambler Drive, Mississauga, Ontario, L4W 2T3

Matsushita Electric Industrial Co., Ltd.
<http://www.panasonic.co.jp/global/>

© 2004 Panasonic Communications Co., Ltd. All Rights Reserved.

E-04091007