

SERVICE DATA SHEET - 242173700

FREEZER ICE MAKER - AUTOMATIC DEFROST BOTTOM FREEZER - R134a

PERFORMANCE DATA NO LOAD & NO DOOR OPENINGS AT 37°/0° CONTROL SETTING (2500++ V4 CONTROLS)

Variable Speed Compressor	65°F (18°C) Ambient	90°F (32°C) Ambient
Operating Time	32 to 40%	100%
Freezer Temperature	-6° to 6°F -21° to -14°C	-6° to 6°F -21° to -14°C
Refrigerator Temperature	33° to 46°F 0.5° to 8°C	33° to 46°F 0.5° to 8°C
Low Side Pressure (cut-in)	5 to 12 psig 34 to 83 kPa	N/A
Low Side Pressure (cut-out)	-2 to 2 psig -14 to 14 kPa	-2 to 2 psig -14 to 14 kPa
High Side Pressure	85 to 95 psig 586 to 655 kPa	120 to 135 psig 827 to 931 kPa
Wattage	40 to 55	60 to 70
Amps (running)	0.5 to 1.1	0.7 to 0.9
Base Voltage	115 vac (127 vac max)	

DEFROST SPECIFICATIONS

Cabinet Size	Thermostat		Heater	
	Cut-in	Cut-out	Watts	Ohms
23' SD, 28' SD, 23' CD	25°F (-4°C)	47°F (8°C)	500	26

Electronic Timer - (ADC) Defrost 24 minutes every 6-96 hours of compressor run time.

CONDENSER FAN MOTOR

Watts	RPM	Amps
3.1 (Energy Star, some models)	1100 CW Opposite Shaft	0.03 Running

FREEZER ICE MAKER SPECIFICATIONS

Electrical	115 vac (127 vac max)
Thermostat	Opens at 48°F (9°C), Closes at 15°F (-9°C)
Heater Voltage	85 vac

FREEZER ICE MAKER CONNECTOR PLUG CONNECTIONS

Wire Number	Wire Color	Connects to:
1	Green / Yellow	Ground
2	Yellow / Blue	Water Valve
3	Black / Orange	Line
4	Light Blue	Neutral

IMPORTANT SAFETY NOTE

The information provided herein is designed to assist qualified repair personnel only. Untrained persons should not attempt to make repairs due to the possibility of electrical shock. Disconnect power cord before servicing this appliance.

IMPORTANT

If any green grounding wires are removed during servicing, they must be returned to their original position and properly secured.

CAUTION

All electrical parts and wiring must be shielded from torch flame. DO NOT allow torch to touch insulation; it will char at 200°F and flash ignite (burn) at 500°F. Excessive heat will distort the plastic liner.

NOTE

This product comes equipped with an Adaptive Defrost Control (ADC). To activate manual defrost, simultaneously press and hold the Fresh Food up (+) and Fresh Food down (-) keys for 5 seconds. A "d" in the freezer temperature window and "F" in the refrigerator temperature window will display when the heater is activated. To deactivate manual defrost, simultaneously press and hold the Fresh Food up (+) and Fresh Food down (-) keys for 5 seconds. A "d" and "F" will be displayed until the defrost cycle is complete.

IMPORTANT

PLEASE RETURN THIS SHEET TO ITS ORIGINAL LOCATION.

ICE MAKER INFORMATION

Test Cycling: Remove cover by inserting screwdriver in notch at bottom and prying cover from housing. Use screwdriver to rotate motor gear counter-clockwise until holding switch circuit is completed. All components of ice maker should function to complete the cycle.

Water Fill Volume: The water fill adjustment screw will change the fill time. One full turn is equal to 20cc (.68 oz.). The correct fill is 102 to 130cc (3.4 to 4.3 oz.). When a water valve is replaced, the fill volume must be checked.

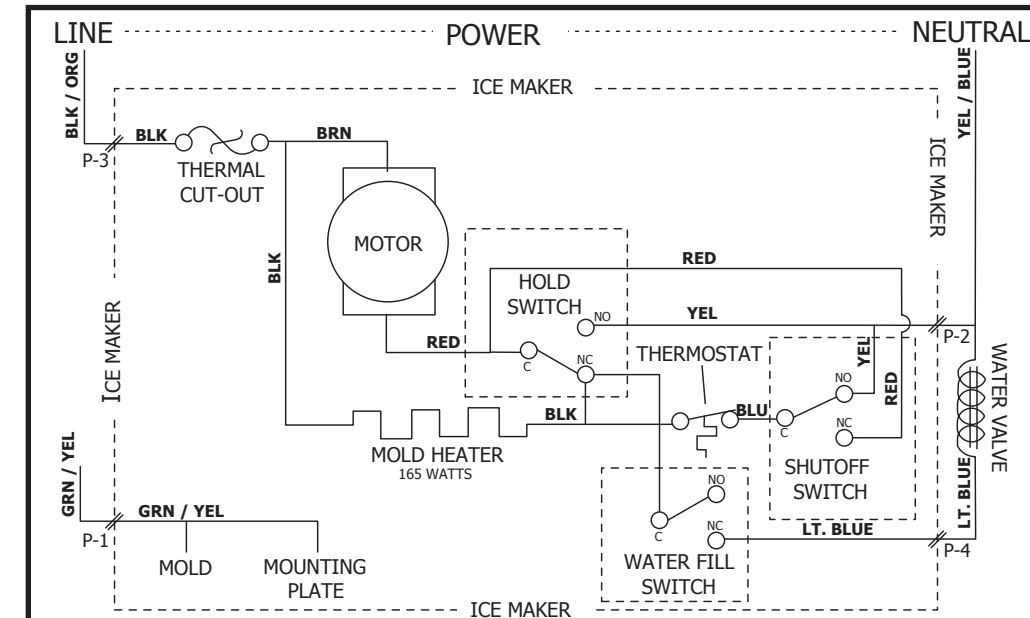
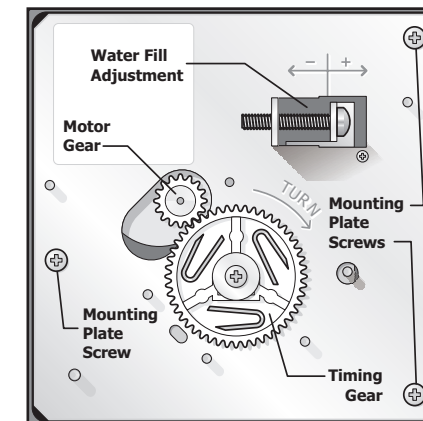

PTD ERROR CODES:
 9X - SHORTED KEY/BUTTON WHERE THE "X" IS:
 1 FOR "ON/OFF"
 2 FOR "+"
 3 FOR "C/F"
 4 FOR "-"
 5 FOR "LOCK"
 6 FOR "V" DOWN ARROW KEY
 7 FOR "V" UP ARROW KEY
 8 FOR "V" DOWN ARROW KEY
 9 FOR "V" UP ARROW KEY
 2X - OPEN NTC, WHERE THE "X" IS:
 1 FOR THE PTD DRAWER NTC
 2 FOR PTD FREEZER AIR NTC
 3 FOR PTD FREEZER AIR NTC
 CE - LOSS OF COMMUNICATION BETWEEN THE UI AND MAIN PCB
 HT - UCL OVER TEMP TIME OUT EXCEEDED
 LOP - LCL UNDER TEMP TIME OUT EXCEEDED

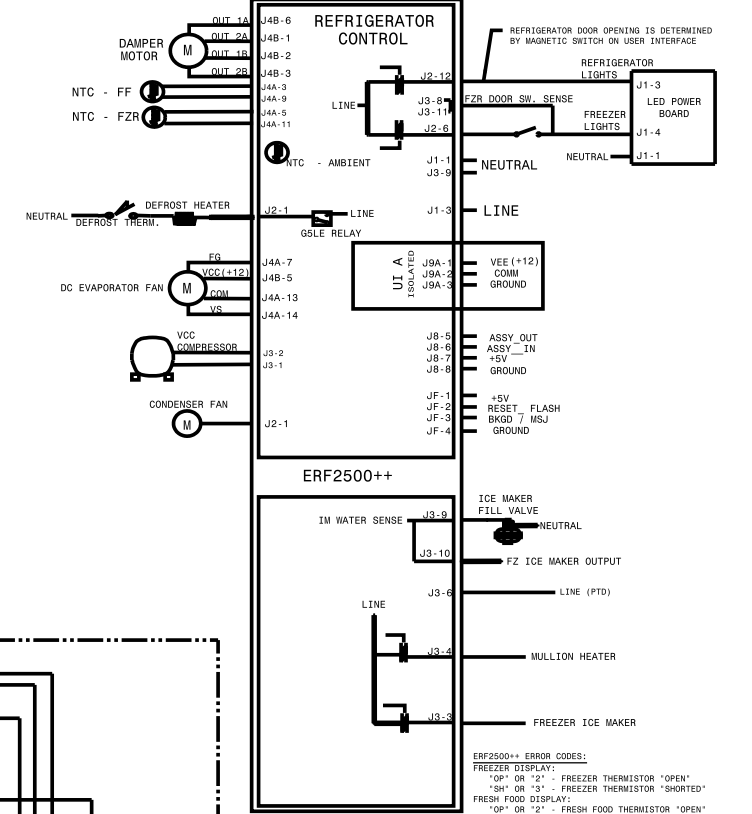
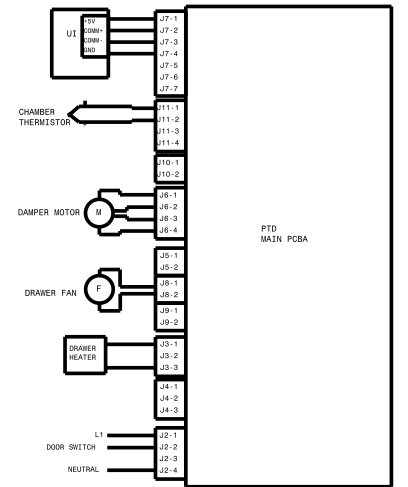
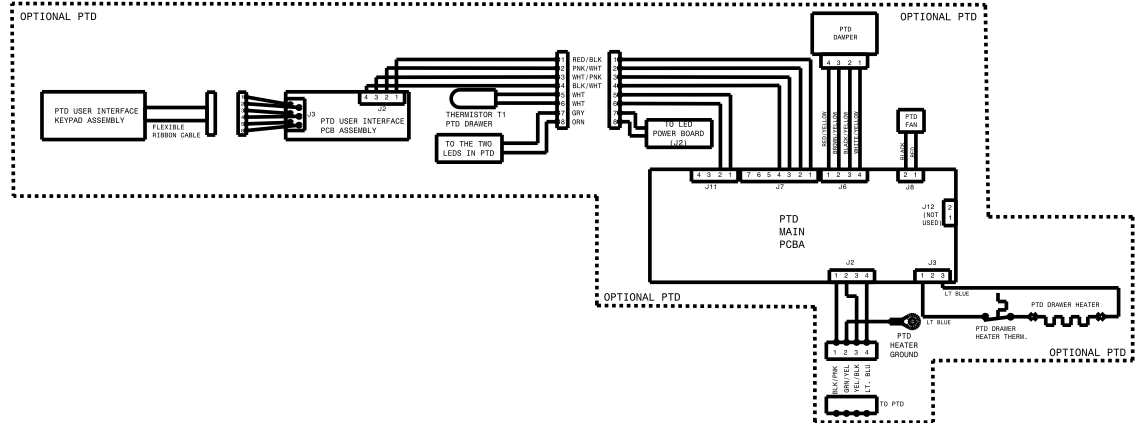

ERF2500++ ERROR CODES:
 FREEZER DISPLAY:
 "OP" OR "2" - FREEZER THERMISTOR "OPEN"
 "SH" OR "3" - FREEZER THERMISTOR "SHORTED"
 FRESH FOOD DISPLAY:
 "OP" OR "2" - FRESH FOOD THERMISTOR "OPEN"
 "SH" OR "3" - FRESH FOOD THERMISTOR "SHORTED"
 BOTH DISPLAYS:
 "SY CE" - COMMUNICATION ERROR
 "SY CF" - COMMUNICATION LOST ERROR
 "SY EF" - EVAPORATOR FAN ERROR

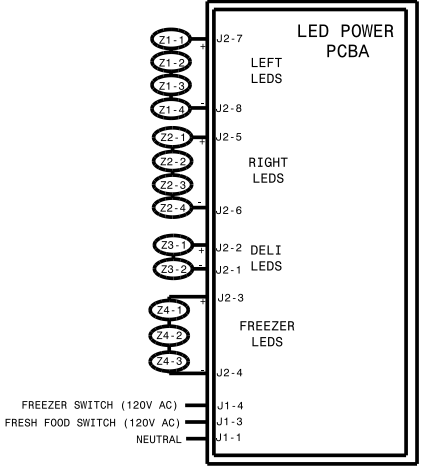
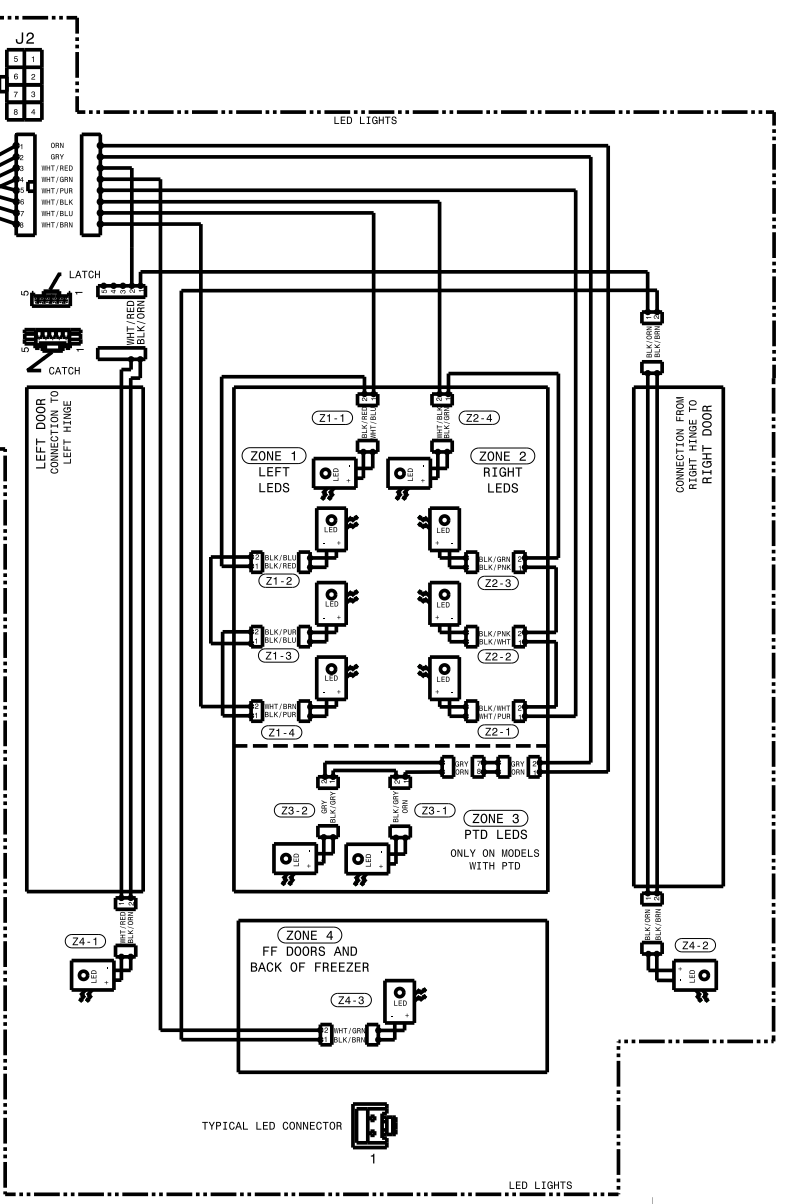
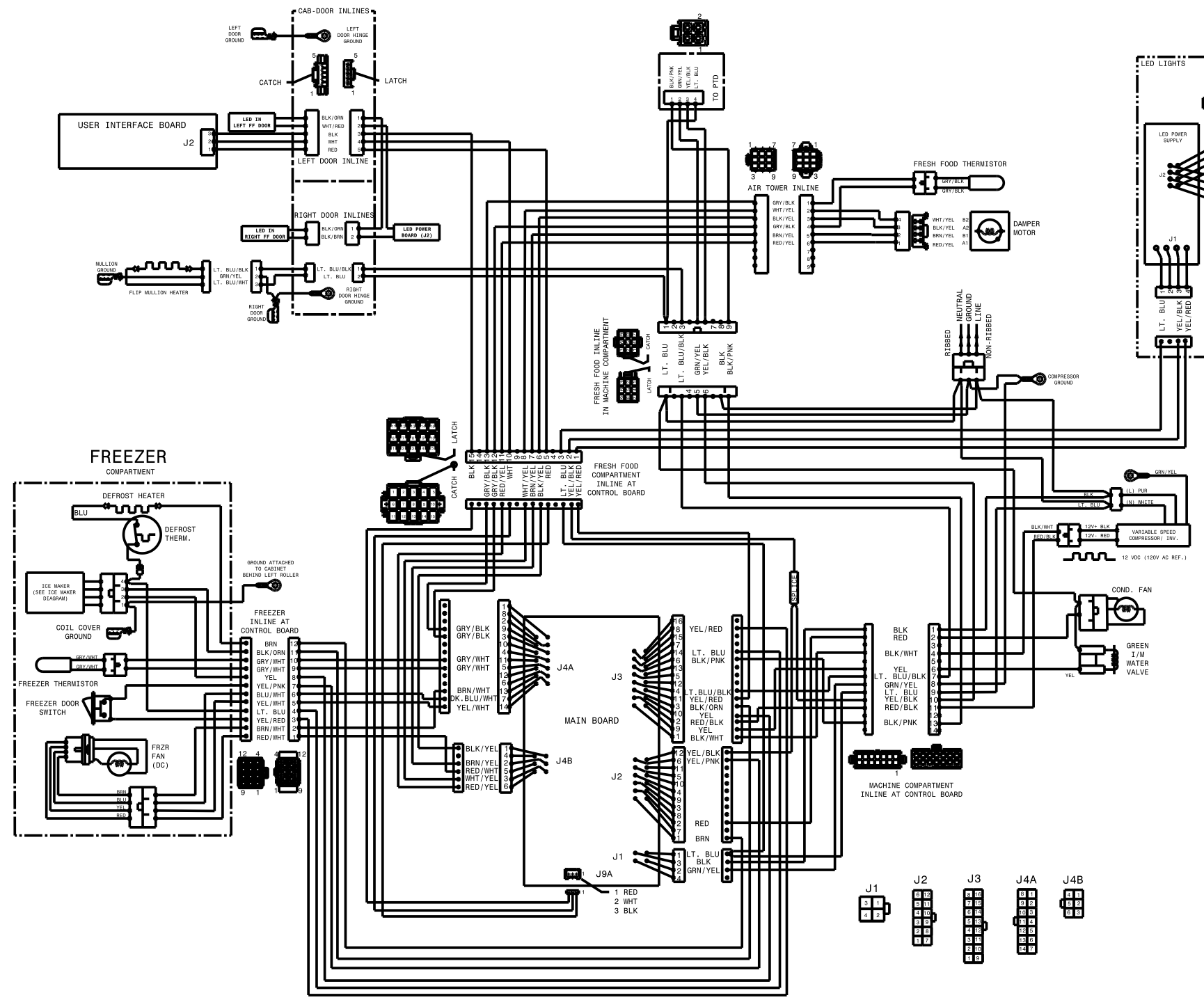

WD-242173801