



Technical Specification

Digital Pressure Switch

ISE30-# Series

ZSE30-# Series

SMC Corporation

Contents

Safety	P2
Model Indication Method	P7
Specification	P8
Full View with Dimensions	P9
Names and Functions of Individual Parts	P12
Installation	P13
Examples of Internal Circuit and Wiring	P15
Setting	P17
Pressure Setting	P19
Other Functions	P21
Attached Table	P22

The Digital Pressure Switch and this technical specification essential information for the protection of users and others from possible injury and damage to property and to ensure correct handling. Please check that you fully understand the definition of the following messages (signs) before going on to read the text, and always follow the instructions. Also read carefully the technical specification of relevant equipment or apparatus before use.

Indications

IMPORTANT MESSAGES	
Read this manual and follow its instructions. Signal words such as WARNING, CAUTION and NOTE, will be followed by important safety information that must be carefully reviewed.	
▲WARNING	Indicates a potentially hazardous situation which could result in death or serious injury if you do not follow instructions.
▲CAUTION	Indicates a potentially hazardous situation which if not avoided, may result in minor injury or moderate injury.
NOTE	Gives you helpful information.

Usage Restrictions

<p>◆ This product is designed for use in general equipment for factory automation. Never use this product with equipment or apparatus that directly concerns human lives*¹, or which malfunction or failure can cause a huge loss.</p> <p>*1: Equipment or apparatus that directly matters human lives means the following:</p> <ul style="list-style-type: none"> • Medical equipment such as life support systems or equipment used in operating rooms • Compulsory equipment required by law such as the Fire Prevention Law, Construction Law and etc. • Equipment or apparatus that conforms with those mentioned above. <p>◆ Contact our sales department when plans are made for the product to be used for the system*² including equipment that concerns itself with the safety of persons or that seriously affects the public. This usage needs special consideration*³.</p> <p>*2: The system including equipment that concerns itself with the safety of persons or that seriously affects the public means the following:</p> <ul style="list-style-type: none"> • Nuclear reactor control systems in nuclear power plants, safety protection systems or other systems important for safety in nuclear power facilities • Driving control systems of mass transportation systems, and flight control systems • Equipment or apparatus that comes into contact with foods or beverages <p>*3: Special consideration means discussing usage with our engineers to establish a safe system designed as fool-proof, fail-safe, redundant and etc.</p> <p>◆ Special consideration of safety or maintainability should be taken to prevent hazard or loss caused by a failure or malfunction that is likely to occur in certain probability due to environmental stress (deterioration).</p> <p>❖ The special consideration means to fully review the equipment or apparatus in design stage and to establish a backup system in advance such as a redundant system or fail-safe system.</p> <p>◆ Use for an interlocking circuit</p> <p>When using the pressure switch as a sensor for interlock, adopt a double interlocking method such as equipping the mechanical protection function in order to deal with a pressure switch failure.</p> <p>Check the pressure switch regularly to ensure proper operation.</p>

Operator

- ◆ This technical specification has been written for those who have knowledge of machinery and apparatus that use pneumatic equipment and have full knowledge of assembly, operation and maintenance of such equipment.
- ◆ Please read this technical specification carefully and understand it before assembling, operating or providing maintenance to the pressure switch.

Safety

WARNING



- ◆ Do not disassemble, modify (including change of printed circuit board) or repair.
An injury or failure can result.
- ◆ Do not operate the pressure switch beyond specification range.
Do not use the pressure switch for inflammable or harmful gas or fluid.
Operation at a range that exceeds the specifications can cause a fire, malfunction, or damage to the pressure switch.
Verify the specifications before use.
- ◆ Do not use the pressure switch in an atmosphere containing combustible or explosive gas.
A fire or explosion can result.
This pressure switch is not an explosion-proof type.
- ◆ These instructions must be followed when using the pressure switch in an interlocking circuit:
 - Provide double interlocking by another system such as mechanical protection.
 - Check the pressure switch regularly to ensure proper operation.Otherwise malfunction can cause an accident.
- ◆ These instructions must be followed while in maintenance:
 - Turn off the power supply.
 - Stop the supplied air, exhaust the residual pressure and verify the release of air before performing maintenance.
Otherwise it can cause injury.
- ◆ Don't use this product near by a place where static electricity is a problem.
Otherwise it can cause failure or malfunction of a system.

CAUTION

- ◆ Perform proper functional checks and leak tests after maintenance.
Stop operation when an abnormality is observed such that the pressure switch does not work properly or there is a leakage of fluid.
Safety is not be assured due to unexpected malfunction.

NOTE

Follow the instruction given below when designing, selection and handling your pressure switch.

- ◆ The instructions on design and selection.
Installation, wiring, environment of use, adjustment, operation and maintenance described below must also be followed.
- ◆ Product specifications
 - This product designed only for the measurement of pressurized air (including vacuums).
The pressurized air must contain no chemicals, synthetic oil with organic solvent, salts nor corrosive gas.
Air that includes these substances can cause damage or malfunction of the digital pressure switch.
Verify the specifications in detail before use.
 - Do not use the product for pressurized air containing plenty of condensed water.
Otherwise it can cause malfunction of the pressure switch.
When measuring the air with condensed water, install an air-dryer / drain catch before filter, and release the condensed water regularly.
Improper draining of condensed water can result in the flow out of condensed water into the secondary piping causing malfunction of pneumatic devices.
Use of the filter with an automatic draining function is recommended when the draining is difficult to perform.
Refer to our manual "Pressurized Air Purifying System" for details of the quality of the pressurized air.
 - Operate the pressure switch with the specified voltage.
Operation with a voltage beyond specifications can cause malfunction or damage of the pressure switch.
Insufficient supply voltage may not drive a load due to a voltage drop inside the pressure switch.
Verify the operating voltage of the load before use.
 - Use the pressure switch within the specified ranges of the measurement flow rate and under the specified operating pressure.
Otherwise it can cause damage to the pressure switch and an abnormal measurement.
Do not apply constant pressure higher than 0.5MPa to vacuum pressure switch. (Specifications : -101 to 101kPa)
 - Do not exceed the specified maximum allowable load.
Otherwise it can cause damage or shorten the lifetime of the pressure switch.
 - Input data to pressure switch is not erased after power is off.
(Rewriting times: 100,000 times, Data duration: 10 years after power off.)
 - Reserve a space for maintenance.
Remember to leave space for maintenance when designing the piping plan.
 - This pressure switch is recognized  marking only if the body initialized  marking.
- ◆ Product handling
 - ◆ Installation
 - Do no drop, hit or apply excessive shock (100 m/s^2) to the pressure switch.
Otherwise it can result in damage to the pressure switch causing failure or malfunction.
 - Do not pull lead wires or lift the body with lead wires. (Tensile strength is less than 35N)
Hold the body when handing.
Otherwise it can result in damage of the pressure switch causing failure or malfunction.
 - Follow the specified tightening torque
Excessive tightening torque can break the pressure switch, bracket, and mounting screws.
Insufficient tightening torque can displace the pressure switch from the original position or loosen the mounting screws.
 - When piping, apply the wrench only to the metal portion (attachment to be piped) integrated into the piping.
Applying the wrench in other position can break the pressure switch.

- Blow off all the dust inside the pipes before piping the pressure switch.
Otherwise it can cause damage or malfunction.
- Clean the inside of the pipe of dust or tape sealant when screwing pipes or joints.
When using tape sealant, leave a couple of screw threads unwrapped with tape sealant.
Otherwise it can cause damage or malfunction.
- Do not apply excessive external force with joints such as hoses when installing with a panel mount adapter.
Otherwise it can damage the pipe joint of the pressure switch or cause drop off from the panel mount adapter.
- Do not insert wires or other foreign matter into the pressure measurement port.
It can damage the pressure sensor causing failure or malfunction.
- Connect frame-ground terminal (FG terminal) to the ground when using a switching power supply.
- Insert a noise filter (power line noise filter, ferrite core, etc.) between the switching power supply and this pressure switch when using analog output.
- Do not apply unnecessary forces such as twisting, pulling, moment loads, etc. on fittings or tubing.
- When using a brand of tubing other than SMC, be careful of the tolerance of the tube's O.D.
 - 1) Nylon tube $\leq \pm 0.1\text{mm}$
 - 2) Soft nylon tube $\leq \pm 0.1\text{mm}$
 - 3) Polyurethane tube $\leq +0.15\text{mm}$, $\leq -0.2\text{mm}$
- This pressure sensor is for air only.
Please contact with SMC if you need to use other fluid.

◆ Wiring

- Do not bend or apply tensile stress to lead wires repeatedly.
Wiring with repetitive bending stress or tensile stress can cause breakage of the lead wires.
Replace the product when damage to a lead wire is observed.
- Connect wires and cables correctly.
Miswiring can break the pressure switch depending on a miswired circuit.
- Do not connect wires while the power is on.
Otherwise it can break the circuit inside the pressure switch causing malfunction.
- Do not lay wires or cables with power cable or high-voltage cable in the same wiring route.
Otherwise the wires to the pressure switch can be contaminated with noise or induced surge voltage from power lines or high voltage lines causing malfunction.
Lay the wires to the pressure switch to a wire duct or in a protective tube other than those for power lines or high voltage lines.
- Verify the insulation of wiring.
Poor insulation (interference with other circuit, poor insulation between terminals and etc.) can introduce excess voltage or current to the pressure switch causing damage.
- Keep wiring as short as possible to prevent contamination from noise and induced surge voltage.
Do not use a cable longer than 10m. Consult with SMC for the use with a cable longer than 10 m.
Connect the 0V DC wire (blue line) directly or as close as possible to the 0V DC terminal of the DC power supply.
- The direct-current power supply to combine should use UL authorization power supply which is the class 2 power supply based on UL 1310 or the power supply is using the transformer of a class 2 based on UL 1585.

◆ Environment

- Do not use the product in an atmosphere containing corrosive gas, chemicals, sea water, water or vapor, or in a place where there is a possibility of adhesion of those substances to the product.
It can cause failure or malfunction.
- Avoid exposure of this product to direct sunlight.
Use sunshades if the product is exposed to direct sunlight.
Otherwise it can cause failure or malfunction.
- Do not use in a place where water, oil or chemicals splashes.
Otherwise it can cause failure or malfunction.

- Do not use a pressure switch nearby a place where electric surges are generated.
Internal circuit elements of the pressure switch can deteriorate or break when equipment generating a large surge (electromagnetic lifter, high frequency induction furnace, motor, etc.) is located near the pressure switch. Provide surge preventives, and avoid interference.
- Do not apply the pressure switch to the load that generates electric surge voltage.
Relays or solenoid valves generate electric surge voltage. When applying the pressure switch to drive these loads directly, use the product equipped with surge absorber.
- The product is not resistive to a lightning surge defined in CE marking. Take measures to protect against a lightning surge at the load side.
- Prevent foreign matter such as remnant of wires from entering this product.
Take proper measures for the remnant not to enter the pressure switch in order to prevent failure or malfunction.
- Do not expose the pressure switch to vibration (less than 98 m/s²), and impact (less than 100 m/s²)
Otherwise it can cause damage or malfunction.
- Follow the specified ranges of the operating fluid and maintain ambient temperatures.
The operating fluid and ambient temperatures should be in the range of 0 to 50 °C.
When operating at low temperature of 5°C or below, breakage or malfunction can occur to the pressure switch due to freezing of condensed water in the pressurized air.
Take preventive measures against freezing. Installation of an air dryer is recommended in order to remove condensed water contained in the measuring fluid.
Do not use the pressure switch in a place where temperature suddenly changes even if it stays within the specified range.
- Do not expose the pressure switch to heat radiation from a heat source located nearby.
It can cause malfunction.
- ◆ Adjustment and Operation
- Do not short-circuit the load.
The pressure switch indicates the error status when a load is short-circuited. However, excess current can damage the pressure switch.
- Do not press the buttons with a sharp object.
It can cause damage to the setting buttons.
- A warm-up time of 20 to 30 minutes is needed for detection of low pressure.
The indication drifts about ±1% soon after the power is on.
- Do not touch the LCD during operation.
The indication on the LCD changes due to static electricity.
- ◆ Maintenance
- Before performing maintenance, make sure to turn off the power supply, stop supplied air, release the residual air in the piping into the atmosphere, and verify that the pneumatic system is open to the air.
Otherwise an unexpected operation of the system component can occur.
- Perform maintenance and check regularly.
Otherwise an unexpected malfunction of the system can occur due to a malfunction of the pressure switch.
- Perform a proper functional check and leak test after maintenance.
Stop operation when an abnormality is observed such that the device does not work properly or there is a leakage of fluid.
Otherwise an unexpected malfunction of the system component can occur.
- Release condensed water regularly.
The flow out of the condensed water to secondary piping can cause a malfunction of pneumatic devices.
- Do not use solvents such as benzene or thinner to clean the pressure switch body.
It can damage the surface of the body and erase the indication on the body.
Use a soft cloth to remove stains. For heavy stains, use a cloth soaked with diluted neutral detergent and fully squeezed, then wipe up the stains again with a dry cloth.

Model Indication Method

For positive pressure : I S E 3 0 - 01 - 25 - M L

For vacuum and low pressure : Z S E 3 0 - 01 - 25 - M A

Pipe Specification

01	R1/8 (M5 internal thread)
T1	NPT1/8(M5 internal thread)
C4H	One-touch fitting φ4, φ5/32inch straight type
C6H	One-touch fitting φ6 straight type
N7H	One-touch fitting φ1/4 inch straight type
C4L	One-touch fitting φ4, φ5/32inch elbow type
C6L	One-touch fitting φ6 elbow type
N7L	One-touch fitting φ1/4 inch elbow type

Output Specification

25	NPN output
65	PNP output
26	1-5V analogue output
28	4-20mA analogue output

Unit Specification

No symbol	Note1) Unit selection function
M	Note2) SI units only

Note1) The new Measurement Law prohibits use in Japan of pressure switches with a unit selection function.

Note2) Fixed unit for vacuum and low pressure is : kPa
for positive pressure is : MPa

Option 1

No symbol	No Lead wire with connector
L	Lead wire with connector

Option 2

No symbol	None
A	Bracket
B	Panel Mount Adapter
D	Panel Mount Adapter + Front Face Protective Cover

Optional Indications

Option	Model number
Lead Wire with Connector	ZS-27-A (Lead wire with Connector : 2m)
Bracket	ZS-27-B (Contained mounting screws : M3×5L 2pcs.)
Panel Mount Adapter	ZS-27-C
Panel Mount Adapter + Front Face Protective Cover	ZS-27-D
Front Face Protective Cover	ZS-27-01
Panel Mount Adapter1	ZS-27-02

Specification

		ZSE30	ISE30
Rated Pressure Range		-100 to 100 kPa	0 to 1 MPa
Set Pressure Range		-101 to 101 kPa	-0.1 to 1 MPa
Withstand Pressure		500 kPa	1.5 MPa
Setting and Display Resolution		0.2 kPa	0.001 MPa
Fluids		Air, inert gases and incombustible gases	
Power Supply Voltage		12 to 24V DC, $\pm 10\%$, ripple (p-p) 10% or less (Protected against inverse connection)	
Current Consumption		45mA or less (No load)	
Switch Output Note 1)		NPN or PNP open collector output .1 output	
Max. Load Current		80mA	
Max. Impressed Voltage		30V (During NPN output)	
Residual voltage		1V or less (@80mA load current)	
Response Time		2.5ms or less (chattering-proof function working :20,160,640 or 1280ms selectable)	
Short Circuit Protection		Provided	
Repeatability		$\pm 0.2\% \text{F.S.} \pm 2$ digits or less	$\pm 0.2\% \text{F.S.} \pm 1$ digit or less
Analog Output	Voltage Output Note 2)	Output Voltage : 1 to 5V $\pm 2.5\% \text{F.S.}$ or less (within rated pressure range) Linearity : $\pm 1\% \text{F.S.}$ or less, Output impedance : Approx. 1k Ω	
	Current Output Note 3)	Output Current : 4 to 20mA $\pm 2.5\% \text{F.S.}$ or less (within rated pressure range) Linearity : $\pm 1\% \text{F.S.}$ or less Max. Load Impedance : 300 Ω (@12VDC), 600 Ω (@24VDC) Min. Load Impedance : 50 Ω	
Hysteresis	Hysteresis Mode	Variable(from 0)	
	Window Comparator Mode		
Display Method		3.5 digits 7-segment display, dual-color display(red/green) Sampling rate:5 times/1 sec	
Indicator Accuracy		$\pm 2\% \text{F.S.} \pm 2$ digits (@25 $\pm 3^\circ \text{C}$)	$\pm 2\% \text{F.S.} \pm 1$ digit (@25 $\pm 3^\circ \text{C}$)
Indicator Lamp		Lit when ON (Green)	
Temperature Characteristic		$\pm 2\% \text{F.S.}$ or less (@25 $^\circ \text{C}$ reference)	
Environment	Enclosure	IP40	
	Ambient Temperature	Operation : 0 to 50 $^\circ \text{C}$, Storage : -10 to 60 $^\circ \text{C}$ (No condensation or no freezing)	
	Ambient Humidity	Operation-Storage : 35 to 85%RH (No condensation)	
	Withstand Voltage	1000VAC, 1 minute (between lead block and case)	
	Insulation Resistance	50M Ω or more @500VDC M (between lead block and case)	
	Vibration proof	10 to 150 Hz, 1.5mm double amplitude, 2 hours each in directions of X, Y and Z respectively	
	Impact proof	100m/s ² , 3 times each in directions of X, Y and Z respectively	
Standard		CE marking, UL/CSA(E216656)	

Note 1) Analog output cannot be selected when switch output is selected.

Note 2) Both switch output and current output cannot be selected simultaneously when voltage output is selected.

Note 3) Both switch output and voltage output cannot be selected simultaneously when current output is selected.

Piping specification

Model		01	T1	C4H	C6H	N7H	C4L	C6L	N7L
Port size		R1/8 M5 \times 0.8	NPT1/8 M5 \times 0.8	-	-	-	-	-	-
	One-touch fitting straight type	-	-	$\phi 4\text{mm}$ $\phi 5/32\text{inch}$	$\phi 6\text{mm}$	$\phi 1/4\text{inch}$	-	-	-
	One-touch fitting elbow type	-	-	-	-	-	$\phi 4\text{mm}$ $\phi 5/32\text{inch}$	$\phi 6\text{mm}$	$\phi 1/4\text{inch}$
Material		Sensor pressure sensing part: silicone, Pipe port: C3602 (electroless nickel plating), O-ring: HNBR			O-ring: NBR		O-ring: NBR, Fitting: PBT		
Mass (Weight)	Lead wires with connector included (2m)	81g		76g		78g			
	Lead wires with connector not included	43g		38g		40g			

Full View with Dimensions

Dimensions of Main Unit

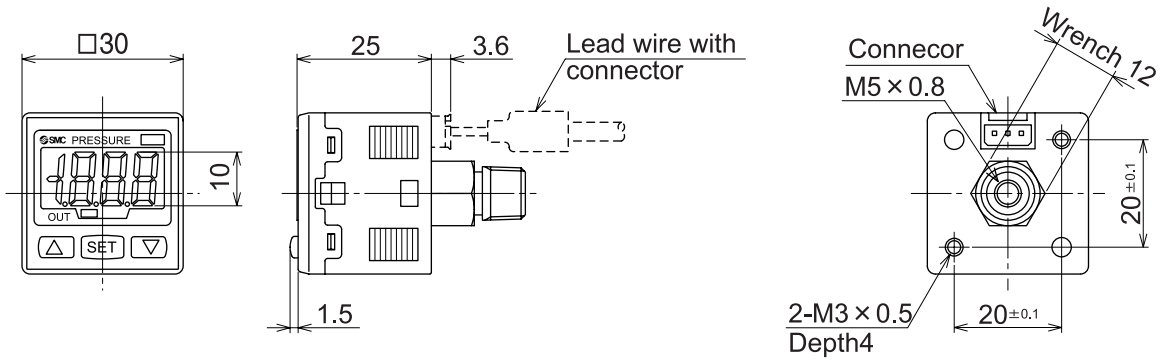

01/T1 type

01: R1/8
T1: NPT1/8

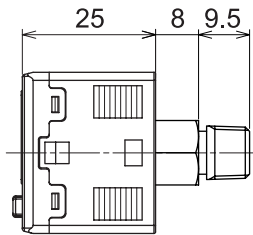

C4H type

$\phi 4$, $\phi 5/32$ [inch]
One touch fitting

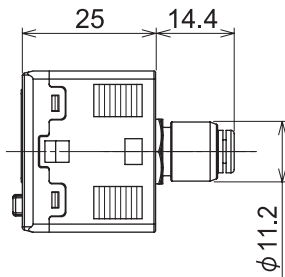

C4L type

$\phi 4$, $\phi 5/32$ [inch]
One touch fitting
elbow type

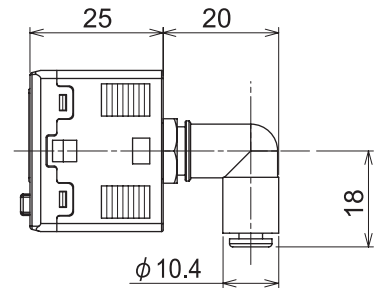

C6H type

$\phi 6$
One touch fitting

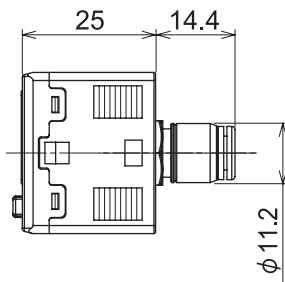

C6L type

$\phi 6$
One touch fitting
elbow type

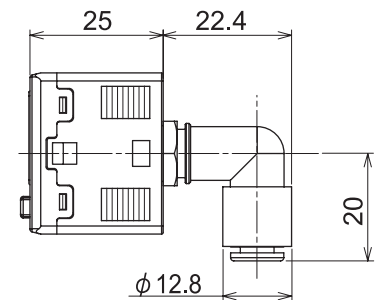

N7H type

$\phi 1/4$ [inch]
One touch fitting

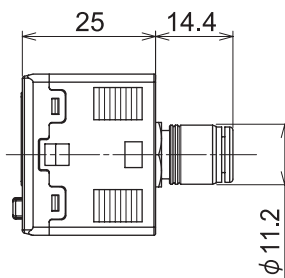

N7L type

$\phi 1/4$ [inch]
One touch fitting
elbow type

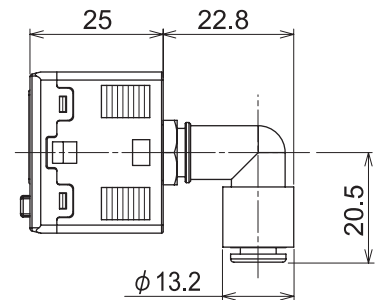

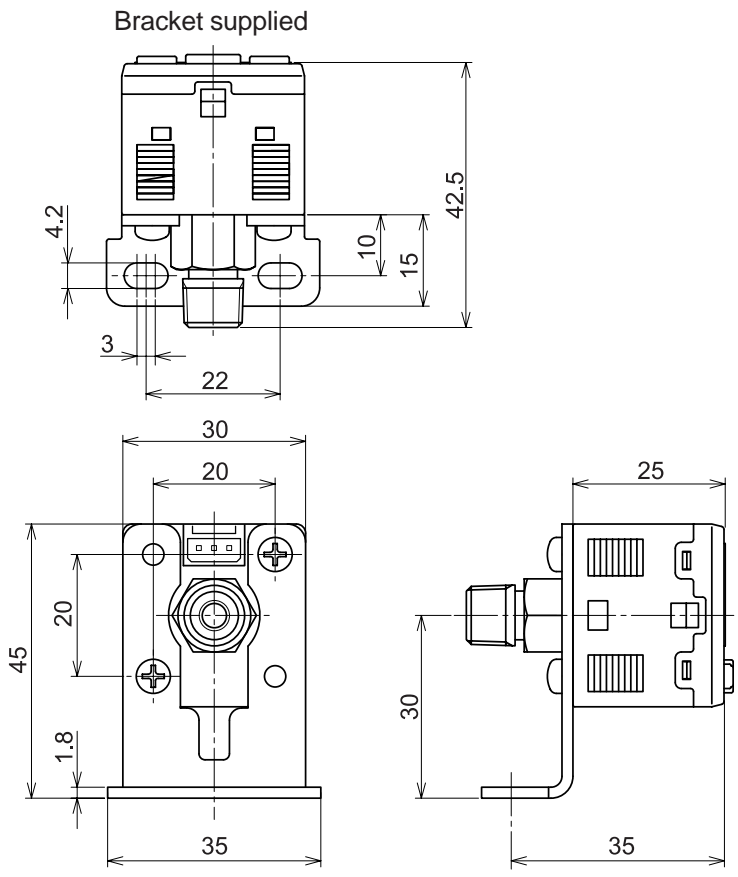

Panel Mount Type

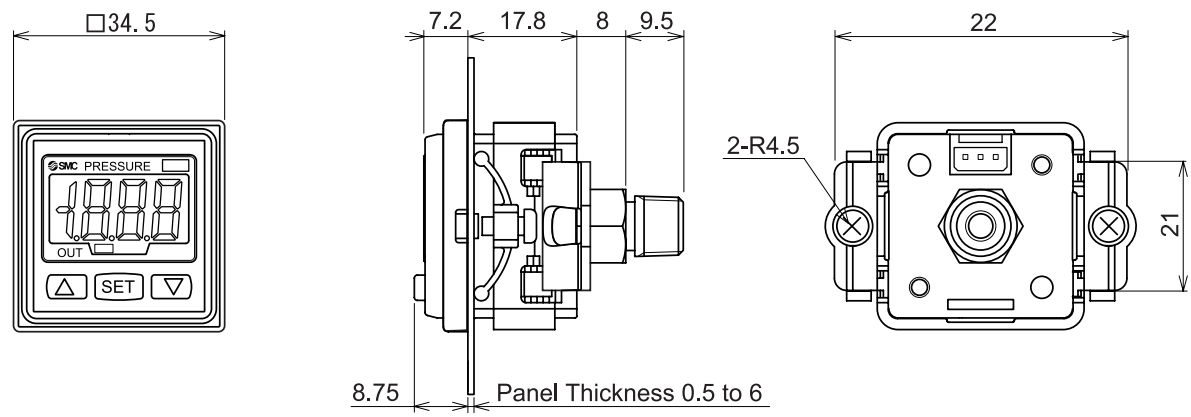

With Front face protective

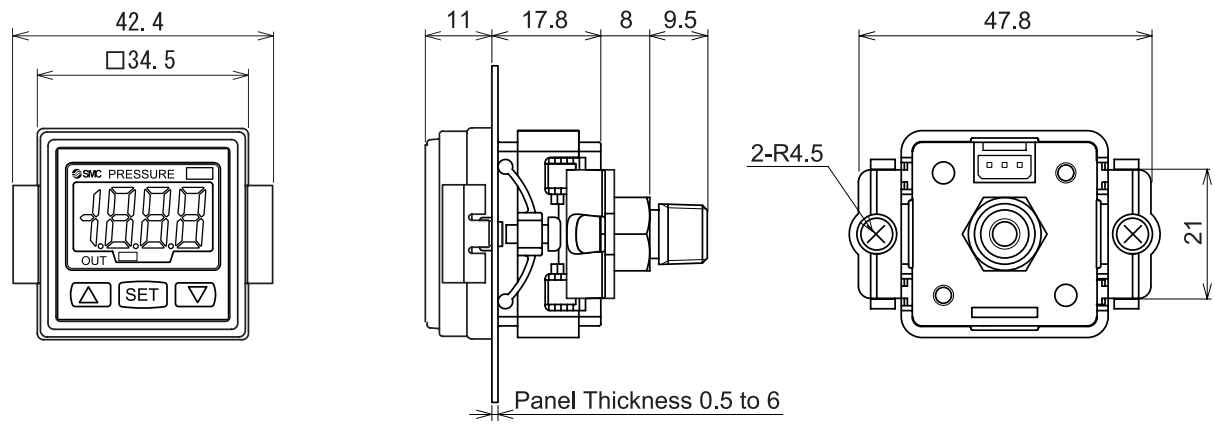

Panel Cut Dimensions

Mounting only 1

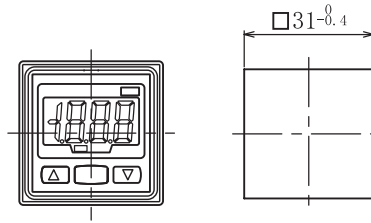

Mounting horizontal (2 to n)

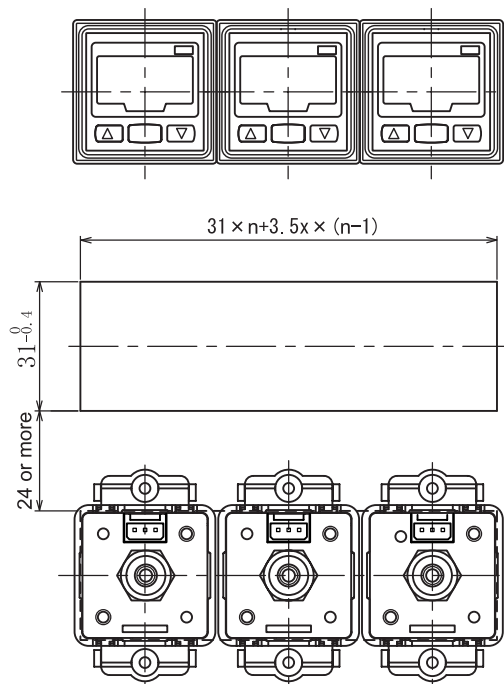

Mounting vertical (2 to n)

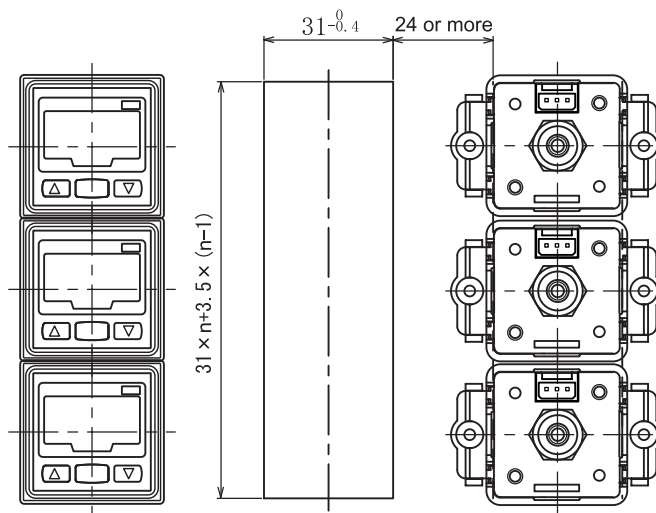

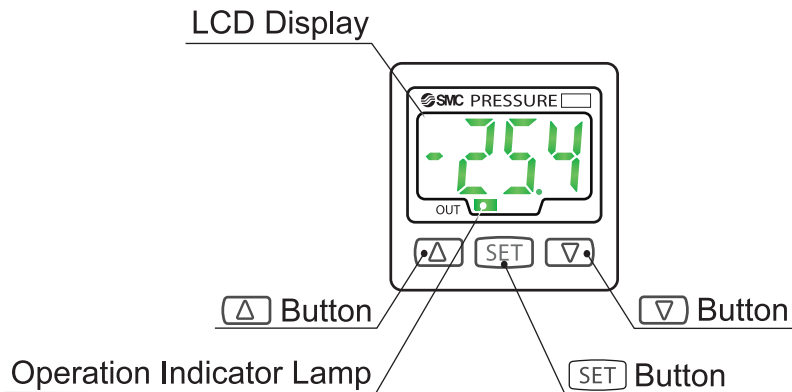

Names and Function of Individual Parts



Operation Indicator Lamp : Displays switch operation condition.
(Green LCD)

LCD Display : Displays the current status of pressure, setting mode, selected indication unit and error code. Four display modes can be selected: display always in red or green only, or changing from green to red linked to output.

Please refer to the matter and the attached table concerning the setting since 17 page for displayed character and value.

-  Button : Increases the mode and ON/OFF set value. Press this button to change to the peak display mode.
-  Button : Decreases the mode and ON/OFF set value. Press this button to change to the bottom display mode.
-  Button : Press this button to change to either mode and to set a set value.

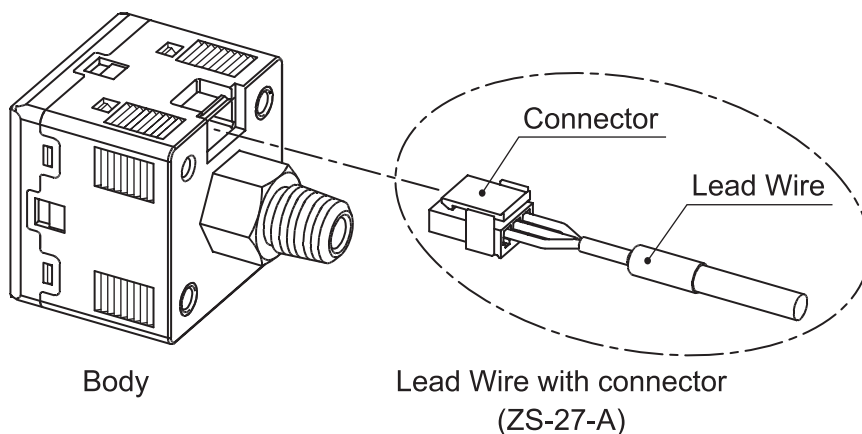

Installation

Install using the special bracket (Article No.ZS-27-B) or the panel mount adapter (Article No.ZS-27-C) available as options.

Caution : Tighten the pipe port at a clamping torque of 7 to 9N-m.
Fasten the bracket mounting screws at a clamping torque of 0.5 to 0.7N-m.

Mounting by Bracket

Mount the bracket on the main unit using the two mounting screws M3 × 5L and install on the facility using hexagon socket head cap screws.

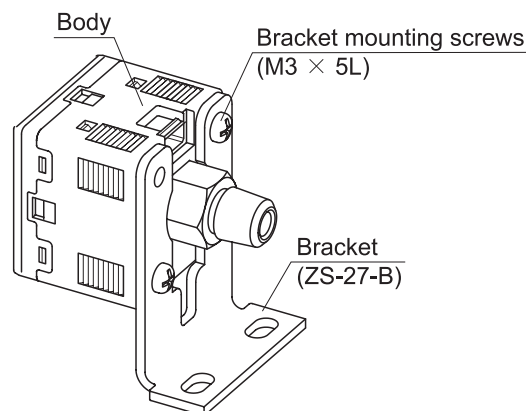

Mounting procedure with the panel mount adapter

1. Mount the panel mount adapter (1) to the switch display side.

Mount the panel mount adapter so that the adapter hook engage with the groove of the switch.

2. Insert the switch from the front of the panel for the switch mount hole.

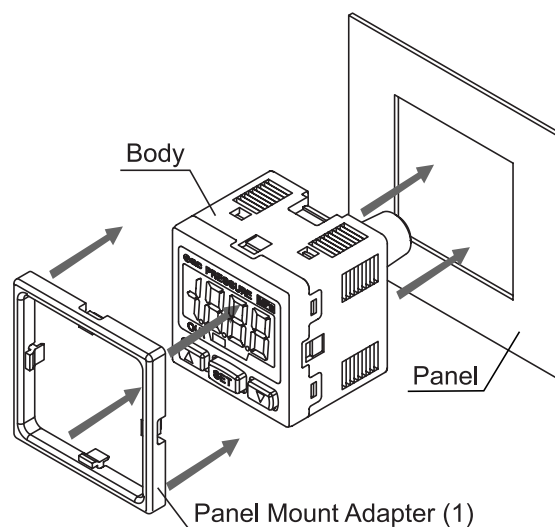

3. Mount the panel mount adapter (2) to the switch from the back of the panel.

Press the panel mount adapter (2) with a driver to the panel for secure mount.

Panel mount adapter (2) can be mounted even when rotated 90°.

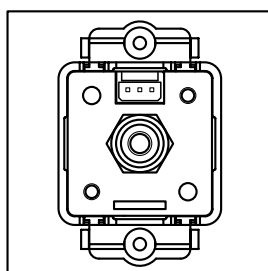
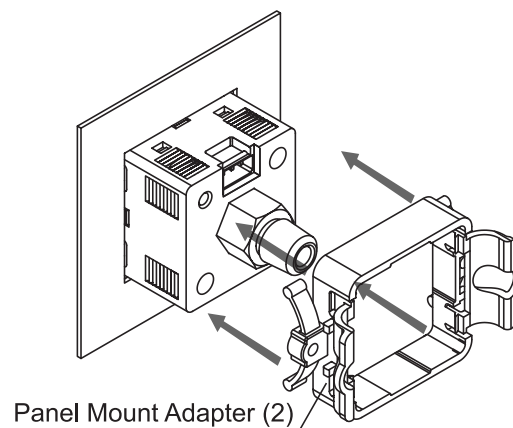

Hook : Vertical

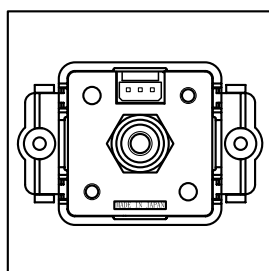

Hook : Horizontal

4. Panel can be reduced by using attached tapping screw.

Notice when removing the switch

Digital pressure switch with adapter for panel mounting can be removed from facility by making hook of the switch wide as following.

Pressure switch and Panel mount adapter may be damaged if you picked up the hook.

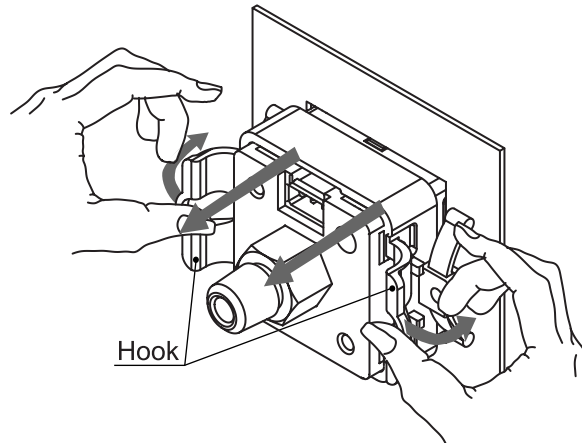

Piping connections

- Cut the tube perpendicularly.
- Grasp the tube, slowly push it into the One-touch fittings until it comes to a stop.

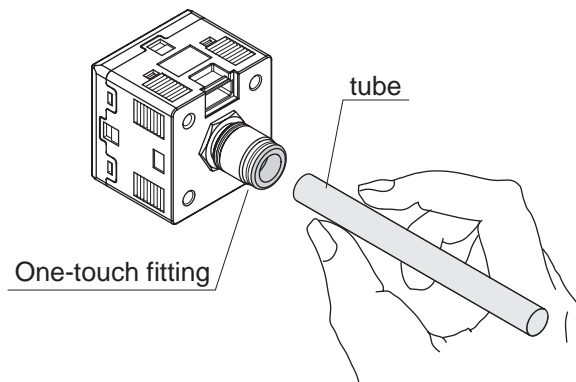

Example of Internal Circuit and Wiring

Output Specification

When the Lead wire with connector provided by SMC CORPORATION is used, the colors of wire (Brown, Black, Blue) will apply as shown on circuit diagram.

-25 NPN Open Collector Output

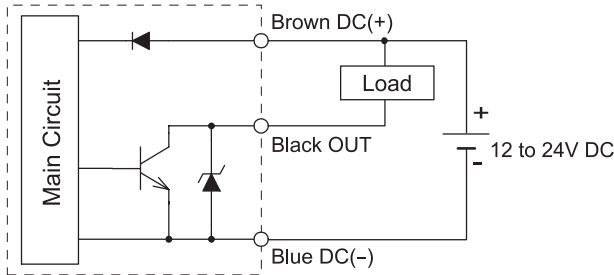

Max. 30V, 80mA
Residual Voltage not exceeding 1V

-65 PNP Open Collector

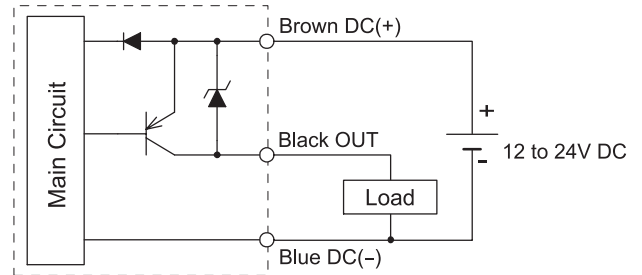

Max 80mA

-26 Analog Output Type

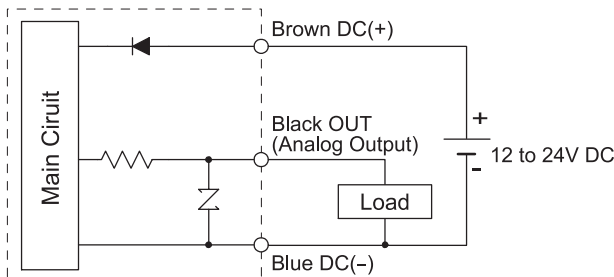

1-5V ($\pm 2.5\%$ F.S.)
Load Impedance : Approx. 1k Ω

-28 Analog Output Type

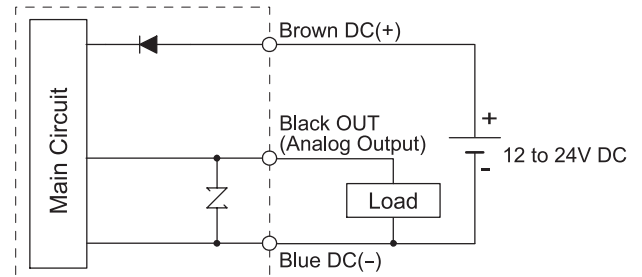

4 to 20mA ($\pm 2.5\%$ F.S.)
Maximum Load Impedance :
300 Ω at 12V power supply voltage
600 Ω at 24V power supply voltage
Minimum Load Impedance : 50 Ω

Connector

Connector Connecting/Disconnecting

- When connecting the connector, insert it straight onto the pin holding the lever and connector body between fingers and lock the connector by pushing the lever claw into the square groove in the housing.
- When disconnecting the connector, push down the lever by thumb to disengage the lever claw from the square groove. Then pull the connector straight out.

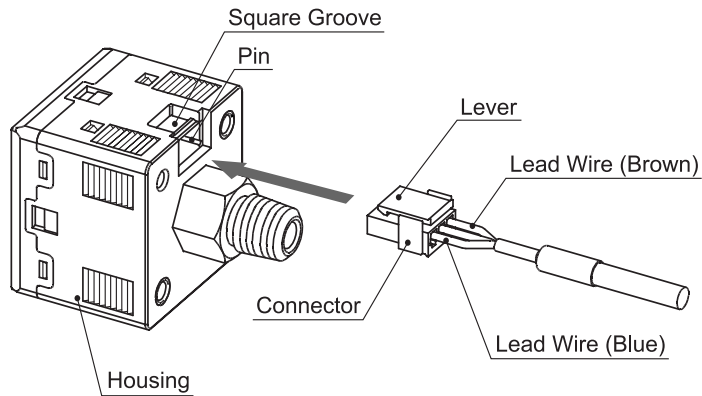

- Please refer the table below for the connector cable (without connector).

Item	Specification
Cable O.D.	$\phi 3.4$
Core no.	3
Conducted normally sectional area	0.2mm^2 (AWG25)
Complying standard	Complies UL2103

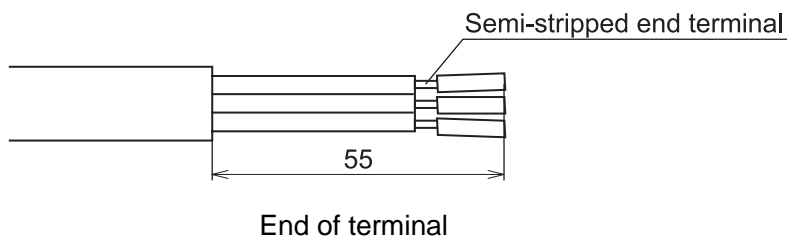

- Use SMC specified connector cable.
If you need different length of lead wire, please contact to SMC sales person.

Setting

Setting Procedures

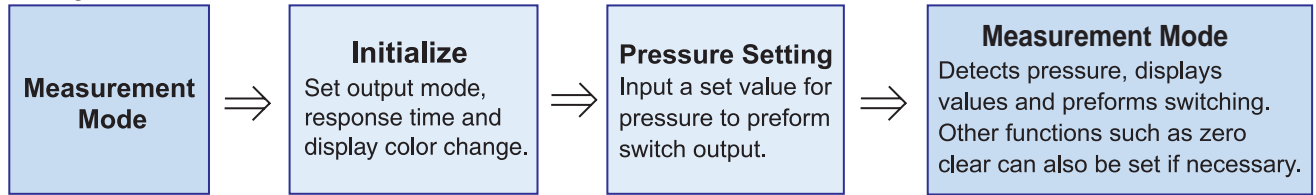

Initialize

Press the **[SET]** button continuously for more than two seconds. The display shown at the right will pop up to allow setting of a display color.

In the case that the unit specification of model indication is M, the SL units will be fixed. If no symbol is supplied, see "Selecting Indication Unit."

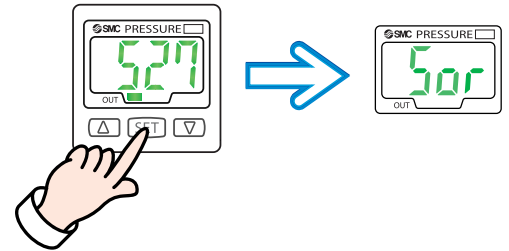

1. Display Color Setting

Select a color for the LCD display.

When changing the display color, press the **[Δ]** or **[▽]** button to select a display color.

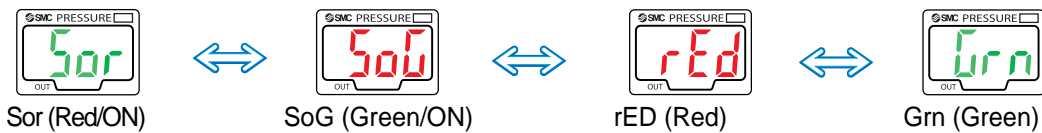

Press the **[SET]** button to set the desired display color and to move on to setting a desired operation mode. If the mode is set to analog output, press the **[Δ]** or **[▽]** button, to select a desired display color from "Grn (Green) ↔ rED (Red)", then press the **[SET]** button. Setting of a desired operation mode will become available.

2. Operation Mode Setting

A desired switch operation mode can be selected.

The operation mode currently selected will be displayed. Select a desired operation mode by pressing the **[Δ]** or **[▽]** button.

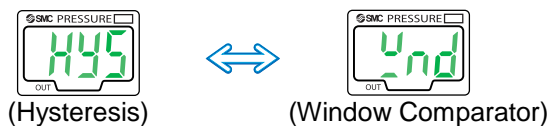

Hysteresis Mode

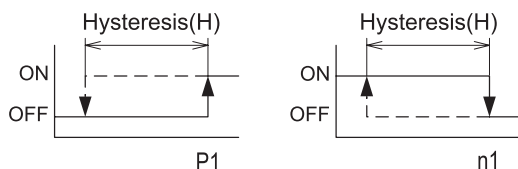

(When the product is shipped)

(Reverse)

Window Comparator Mode

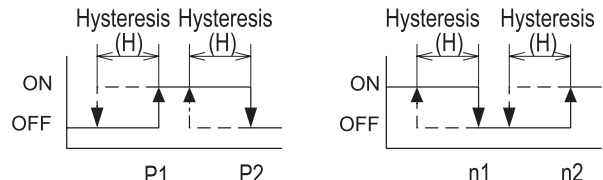

(When the product is shipped)

(Reverse)

Press the **[SET]** button to move on to setting an output node.

3. Auto Preset Setting

A desired output mode can be set freely for switch output.

The output mode currently selected will be displayed.

Press the **[Δ]** or **[▽]** button to switch to normal output "no" or reverse output "nC".



Press the **[SET]** button to move on to setting a desired response time.

4. Response Time Setting

A response time for switch output can be set as user desires.

Setting of a response time prevents chattering output.

The response time currently set will be displayed. Select a desired response time by pressing the Δ or ∇ button.



Press the SET button to set and move on to setting Auto Preset mode.

If the operating mode is set to Hysteresis, press the SET button to set and return to Measurement mode.

5. Auto Preset Setting

This function stores in the memory a measurement pressure as a reference value when Auto Preset input is set.

The setting currently set will be displayed. Press the Δ or ∇ button to set to Auto Preset.

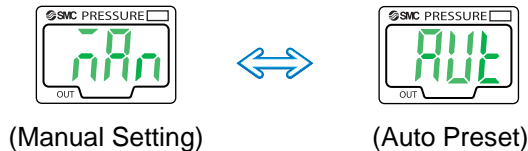

Press the SET button to return to the Measurement mode.

Selecting Indication Unit (If the unit specification of the model indication is without "M")

The indication unit can be selected freely.

Pressing the Δ or ∇ button will change the unit and will automatically convert set values.

The units will change in the following order : PA \leftrightarrow GF \leftrightarrow bAr \leftrightarrow PSi \leftrightarrow inH \leftrightarrow mmH

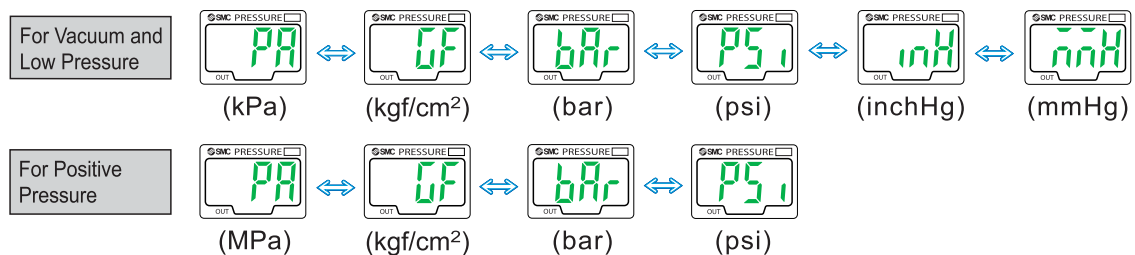

Press the SET button to set and to move on to setting a display color.

Resolution of each units

Setting and Display Resolution	ISE 30	ZSE 30
Pa	0.001MPa	0.2kPa
Kgf/cm ²	0.01	0.002
bar	0.01	0.002
psi	0.2	0.05
mmHg	—	2
inchHg	—	0.2

Pressure Setting

If set to Manual Setting

Press the **[SET]** button in the Measurement mode to display set values. "P_1" or "n_1" and the current set value will flicker alternately. Press the **[SET]** button to display the next set value. Press the **[▽]** or **[△]** button to enter into the Value Change mode. (See "Value Setting")

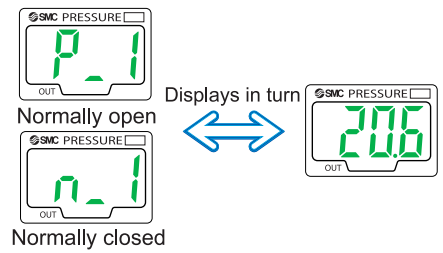

If Hysteresis mode is set

If the Hysteresis mode is set, "H" and the set value of Hysteresis will be displayed alternately after the setting for "P_1".

Press the **[SET]** button to return to the normal Measurement mode. Press the **[△]** or **[▽]** button to enter into the Value Change mode. (See "Value Setting")

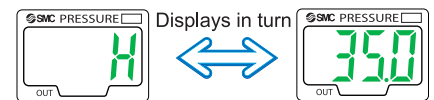

If set to Normally Open Mode

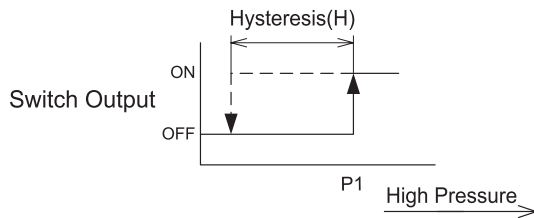

If set to Normally Closed Mode

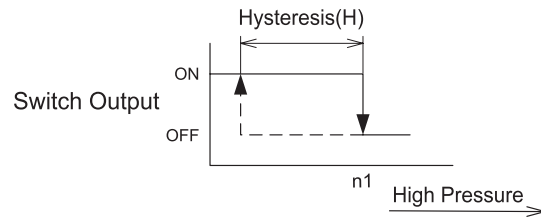

In case Hysteresis is set at less than or equal to 2 digits, switch output may chatter if input pressure fluctuates near the set point.

If window comparator mode is set

If the Window comparator mode is set, "P_2" or "n_2" and the current set value will be displayed alternately after the setting for "P_1". Press the **[SET]** button to display the next set value. (Hysteresis : H) Press the **[△]** or **[▽]** button to enter into the Value Change mode. (See "Value Setting")

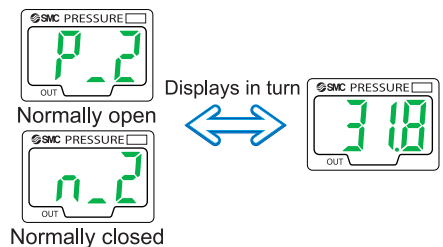

Next, "H" and the set value of Hysteresis will be displayed alternately. Press the **[SET]** button to return to the normal Measurement mode. Press the **[△]** or **[▽]** button to enter into the Value Change mode. (See "Value Setting")

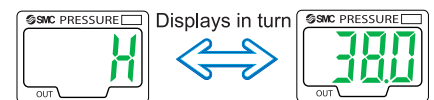

If set to Normally Open Mode

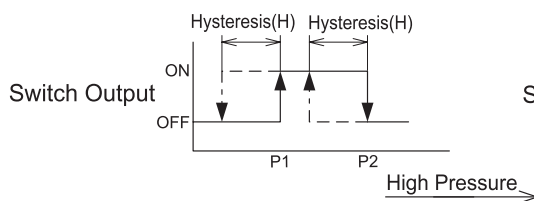

If set to Normally Closed Mode

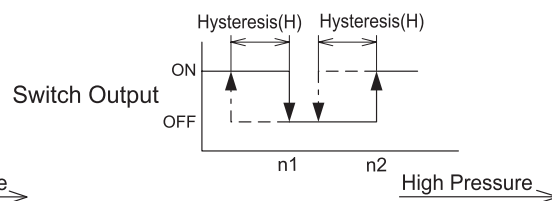

If the initialize value is the Normally Open mode, "P_1" will be displayed. "n_1" will be displayed if it is Normally Closed mode. The set pressure value can be checked without holding or stopping switch output operation.

If set to Auto Preset Mode

Press the **[SET]** button during the Measurement mode to ready Auto Press mode and "AP1" will be displayed. Setting pressure in this condition will ready the equipment. Press the **[Δ]** and **[▽]** buttons simultaneously while "AP1" is displayed to return to the measurement mode.

To execute Auto Preset, press the **[SET]** button and "A1L" will be displayed. Perform adsorption and desorption operations. Detection will be made and a set value will be stored in the memory automatically.

Press the **[SET]** button while "A1L" is displayed to finish setting and to return to the normal measurement mode.

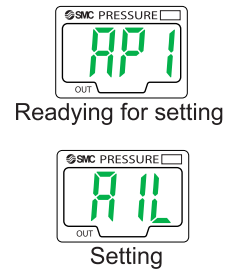

Value Setting

To input value for pressure setting or other purposes:

1. Press the **[Δ]** or **[▽]** button to enter the Set Value Change mode. The first row will flicker.
2. Press the **[Δ]** or **[▽]** button to set a desired value.
(No operation within ten seconds after the Set Value Change mode was selected results automatic setting of the value appearing in the display window and in charging of the mode from Set Value Change mode to Set Value Indication mode.)
3. Press the **[SET]** button to make the value one digit higher flicker.
(If the highest place is zero, " " or " " will flicker. " " means "+zero", " " means "-zero", " -1" means "-1")
(In the case that the **[SET]** button is pressed in the highest place, the first digit will flicker.)
4. Press the **[SET]** button continuously for longer than one second to return to displaying set values.

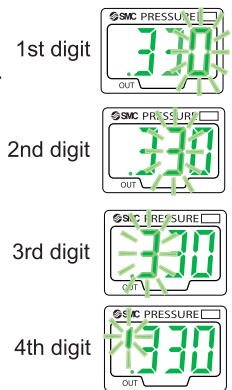

Fine Adjustment Mode

(Fine Adjustment Function of Display Value)

Press the **[SET]** button and **[▽]** buttons simultaneously for longer than two second in the Measurement mode. "FSI" and current pressure Measurement value will be displayed. Press the **[Δ]** or **[▽]** button to change the set value. If no operation is made for longer than two seconds or press the **[SET]** set button, the pressure switch will display the current pressure Measurement value which will then flicker adjusted with "FSI". Press the **[SET]** button to display an adjusted amount (percentage), which will then flicker alternately with "FSC". Press the **[SET]** button to return to the normal Measurement mode.

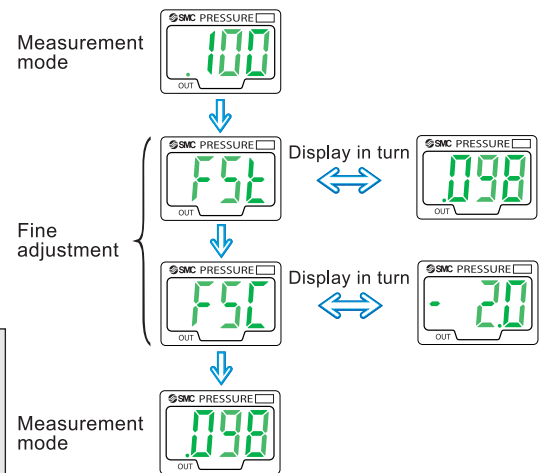

This function wake no dispersion each output value. It is possible to fine adjustment within $\pm 5\%$ (ISE), $\pm 2.5\%$ (ZSE) range of the reading data on the displayed value of pressure sensor.

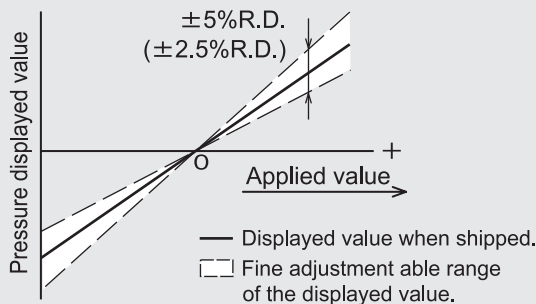

Note) When fine adjustment function is conducted, pressure setting value is sometimes changed by ± 1 digit.

Other Function

Peak And Bottom Hold Display Function

Maximum and minimum values are always detected and updated during measurement.

Displayed values can be held. In peak hold, press the Δ button for longer than one second to make flicker and to hold the maximum pressure value.

To reset holding, press the Δ button again for more than one second. The Measurement mode will be set.

In bottom hold, press the ∇ button for longer than one second to make flicker and to hold the minimum pressure value.

To reset holding, press the ∇ button again more than one second. The Measurement mode will be set.

Key Lock Function

This function prevents malfunction such as a set value being changed by mistake. Press the SET button for longer than four seconds to display which of "Loc" or "UnL" is currently set.

Select by pressing the Δ or ∇ button and set by pressing the SET button. If button operation is not desired, set to "Loc" to set the Lock mode.

To release key lock, press the SET button for longer than four seconds to display the current setting and to "UnL".

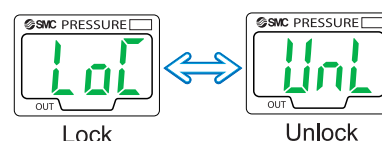

Zero Clear Function

A displayed value can be adjusted to zero when pressure to be measured is within ± 70 digits of the atmospheric pressure.

(The range of $\pm 10\%$ F.S. setting is different depending on the individual product difference)

This function is useful because it enables detecting pressure fluctuations larger than a certain level without being influenced by fluctuations of source pressure. Press continuously the Δ and ∇ buttons simultaneously to reset "0" on the display. To return to the Measurement mode, remove the fingers from the buttons.

Error Display Function

This function displays error location and nature when a problem or an error occurs.

Error Name	Error Display	Error Nature	Troubleshooting Method
Overcurrent Error	Er 1	A load current of switch output is flow 80mA or more.	Turn the power off and remove the Output factor for the overcurrent. Then turn the power on.
Residual Pressure Error	Er 3	Pressure more than ± 0.071 MPa for 1MPa or more than ± 7.1 kPa for vacuum compared with the atmospheric pressure is applied during zero clear operation. In three seconds, the mode will reset to the Measurement mode. $\pm 10\%$ F.S. of the setting range changes with individual product differences.	Preform zero-clear operation Again after restoring the applied Pressure to an atmospheric Pressure condition.
Pressurizing Error	HHH	Pressure exceeding the high limit of the set pressure range is applied.	Reset applied pressure to a level Within the set pressure range.
	LLL	Pressure exceeding the low limit of the set pressure range is applied.	
System Error	Er 4	Displayed in the case of an internal data error.	Turn the power off and turn it on again. If resetting fails, an investigation By SMC CORPORATION Will be required.
	Er 6	Displayed in the case of an internal data error.	
	Er 7	Displayed in the case of an internal data error.	
	Er 8	Displayed in the case of an internal data error.	

Attached Table

1. Display color

Display	Display character	Meaning
	Sor	When turning it on, it red displays it.
	SoG	When turning it on, it green displays it.
	rEd	Red
	Grn	Green

2. Output mode

Display	Display character	Meaning
	no	Normal open
	nc	Normal close

3. Key lock

Display	Display character	Meaning
	Loc	Lock
	UnL	Unlock

4. Auto Preset

Display	Display character	Meaning
	Aut	Auto Preset is selected.
	AP1	State of preparation of Auto Preset
	A1L	Auto Preset is being set.

Setting of figure

(Display of segment in left end)









Display	Display character
	0
	-0
	1
	-1

Setting of figure



(Display of segment of treble)

Display	Display character
	0.012
	0.345
	0.678
	0.900

5. Manual set

Display	Display character	Meaning
	mAn	Manual set
	Hys	Hysteresis mode (Display when operation mode is set)
	Wnd	Window comparator mode (Display when operation mode is set)
	P_1	Hysteresis mode and Window comparator mode (When P_1 of the setting of pressure is set, it displays it.)
	P_2	Window comparator mode (When P_2 of the setting of pressure is set, it displays it.)
	n_1	Hysteresis mode and Window comparator mode (When n_1 of the setting of pressure is set, it displays it.)
	n_2	Window comparator mode (When n_2 of the setting of pressure is set, it displays it.)
	H	Display when pressure is set

6. Fine Adjustment Mode

Display	Display character	Meaning
	Fst	When the adjustment amount is set and, it displays it in the place where the minute adjustment mode is selected.
	Fsc	Amount of adjustment (Display it by percent.)