

WOODS

111874 LOADER MOUNTING KIT
for LU126, LU132, 1020, 1027 Loaders

on New Holland[®] Tractors
TN55, TN60A, TN65
TN70, TN70A, TN75, TN75A

and Case IH[®] Tractors:
JX1060C, JX1070C, JX1075C

includes Hose Kits
58025, 46945, 1010460
1023577, 1023583, 1023584

MAN0041

(Rev. 4/4/2008)



WOODS[®]
Tested. Proven. Unbeatable.

INSTALLATION MANUAL

TO THE DEALER:

Assembly and proper installation of this product is the responsibility of the Woods® dealer. Read manual instructions and safety rules. Make sure all items on the Dealer's Pre-Delivery and Delivery Check Lists in the Loader Operator's Manual are completed before releasing equipment to the owner.

TO THE OWNER:

Read this manual and Loader Operator's Manual before operating your Woods equipment. The information presented will prepare you to do a better and safer job. Keep this manual handy for ready reference. Require all operators to read this manual carefully and become acquainted with all adjustment and operating procedures before attempting to operate. Replacement manuals can be obtained from your dealer. To locate your nearest dealer, check the Dealer Locator at www.WoodsEquipment.com, or in the United States and Canada call 1-800-319-6637.

The equipment you have purchased has been carefully engineered and manufactured to provide dependable and satisfactory use. Like all mechanical products, it will require cleaning and upkeep. Lubricate the unit as specified. Observe all safety information in this manual and safety decals on the equipment.

For service, your authorized Woods dealer has trained mechanics, genuine Woods service parts, and the necessary tools and equipment to handle all your needs.

Use only genuine Woods service parts. Substitute parts will void the warranty and may not meet standards required for safe and satisfactory operation. Record the model number of your equipment in the space provided.

Model: _____

Date of Purchase: _____

Provide this information to your dealer to obtain correct repair parts.

Throughout this manual, the term **NOTICE** is used to indicate that failure to observe can cause damage to equipment. The terms **CAUTION**, **WARNING**, and **DANGER** are used in conjunction with the Safety-Alert Symbol (a triangle with an exclamation mark) to indicate the degree of hazard for items of personal safety.



This is the safety alert symbol. It is used to alert you to potential personal injury hazards. Obey all safety messages that follow this symbol to avoid possible injury or death.



Indicates a hazardous situation which, if not avoided, will result in death or serious injury.



Indicates a hazardous situation which, if not avoided, could result in death or serious injury.



Indicates a hazardous situation which, if not avoided, could result in minor or moderate injury.

**IMPORTANT
or NOTICE**

Is used to address practices not related to personal injury.

NOTE

Indicates helpful information.

WOODS®

ALITEC™
BMP®
CENTRAL FABRICATORS®
GANNON®
GILL®
WAIN-ROY®
WOODS®

2 Introduction

LMK (Rev. 7/20/2007)



SAFETY RULES

ATTENTION! BECOME ALERT! YOUR SAFETY IS INVOLVED!



¡LEA EL INSTRUCTIVO!

Si no lee Ingles, pida ayuda a alguien que si lo lea para que le traduzca las medidas de seguridad.

Safety is a primary concern in the design and manufacture of our products. Unfortunately, our efforts to provide safe equipment can be wiped out by an operator's single careless act.

In addition to the design and configuration of equipment, hazard control and accident prevention are dependent upon the awareness, concern, judgement, and proper training of personnel involved in the operation, transport, maintenance, and storage of equipment.

It has been said, "The best safety device is an informed, careful operator." We ask you to be that kind of operator.

INSTALLATION

- This Loader Mounting Kit is to be used only for the loaders and tractors specified in this manual. Any other use or modification of this mounting kit may result in serious injury or death.
- Hydraulics must be connected as instructed in this manual. Do not substitute parts, modify, or connect in any other way.
- After connecting hoses, check that all control lever positions function as instructed in the Operator's Manual. Do not put into service until control lever and equipment movements are correct.
- Safety instructions are important! Read all attachment and power unit manuals; follow all safety rules and safety decal information. (Replacement manuals and safety decals are available from your dealer. To locate your nearest dealer, check the Dealer Locator at www.WoodsEquipment.com, or in the United States and Canada call 1-800-319-6637.) Failure to follow instructions or safety rules can result in serious injury or death.
- Keep hands and body away from pressurized lines. Use paper or cardboard, not hands or other body parts to check for leaks. Wear safety goggles. Hydraulic fluid under pressure can easily penetrate skin and will cause serious injury or death.
- Make sure that all operating and service personnel know that if hydraulic fluid penetrates skin, it

must be surgically removed as soon as possible by a doctor familiar with this form of injury or gangrene, serious injury, or death will result. **CONTACT A PHYSICIAN IMMEDIATELY IF FLUID ENTERS SKIN OR EYES. DO NOT DELAY.**

- Check that all hardware is properly installed. Always tighten to torque chart specifications unless instructed otherwise in this manual.
- Air in hydraulic systems can cause erratic operation and allows loads or equipment components to drop unexpectedly. When connecting equipment or hoses or performing any hydraulic maintenance, purge any air in hydraulic system by operating all hydraulic functions several times. Do this before putting into service or allowing anyone to approach the equipment.
- Protective hose sleeves must cover all hydraulic hoses within 20 inches of the operator and be secured onto metal hose fittings. Replace hoses or sleeves if damaged or if protective sleeve cannot be properly positioned or secured.
- Make sure all hydraulic hoses, fittings, and valves are in good condition and not leaking before starting power unit or using equipment. Check and route hoses carefully to prevent damage. Hoses must not be twisted, bent sharply, kinked, frayed, pinched, or come into contact with any moving parts. Operate moveable components through full operational range to check clearances. Replace any damaged hoses immediately.
- Always wear relatively tight and belted clothing to avoid getting caught in moving parts. Wear sturdy, rough-soled work shoes and protective equipment for eyes, hair, hands, hearing, and head; and respirator or filter mask where appropriate.
- Do not modify or alter or permit anyone else to modify or alter the equipment or any of its components in any way.
- Do not allow bystanders in the area when operating, attaching, removing, assembling, or servicing equipment.
- Use a suitable lifting device of sufficient capacity. Use adequate personnel to handle heavy components.
- Keep all persons away from operator control area while performing adjustments, service, or maintenance.

LOADER MOUNT INSTALLATION

WARNING

■ Only use 111874 Loader Mounting Kit for mounting Woods LU126, LU132, 1020, 1027 loaders on New Holland® TN55, TN60A TN65, TN70, TN70A, TN75, TN75A tractors and Case IH® JX1060C, JX1070C, and JX1075C tractors. Any other use or modification of this mounting kit may result in serious injury or death.

■ Safety instructions are important! Read all attachment and power unit manuals; follow all safety rules and safety decal information. (Replacement manuals and safety decals are available from your dealer. To locate your nearest dealer, check the Dealer Locator at www.WoodsEquipment.com, or in the United States and Canada call 1-800-319-6637.) Failure to follow instructions or safety rules can result in serious injury or death.

■ Do not modify or alter or permit anyone else to modify or alter the equipment or any of its components in any way.

CAUTION

■ Always wear relatively tight and belted clothing to avoid getting caught in moving parts. Wear sturdy, rough-soled work shoes and protective equipment for eyes, hair, hands, hearing, and head; and respirator or filter mask where appropriate.

■ If you do not understand any part of this manual and need assistance, see your dealer.

NOTICE

■ This equipment must be assembled and installed on the customer's tractor by the Woods dealer. Dealer must thoroughly inspect equipment and complete each item on the PRE-DELIVERY CHECK LIST, DELIVERY CHECK LIST, and PRODUCT REGISTRATION from the loader manual before equipment is released to the customer.

Tractor Preparation

For installing this mounting kit, references to right, left, forward, and rearward directions are determined from the operator's position in the tractor seat.

1. Remove the tractor front weights and front fenders, if equipped.
2. Rotate the exhaust pipe opening to face away from the left side of the tractor.

NOTE: On TNA models the tip of the exhaust pipe will have to be removed and a weather cap installed. See page 6 for installation instructions.

3. Set the tractor wheels to the manufacturer's widest recommended spacing. Refer to the tractor operator's manual.

NOTICE

■ Clean threaded holes in the tractor chassis thoroughly, using a tap of the proper size. Paint, rust, or debris in the threads may not permit cap screws to be installed and tightened correctly.

As a valued customer, Woods appreciates your comments. Once loader mount and hydraulic hoses have been installed, please take a few minutes to complete the Loader Mount Evaluation sheet that was supplied with this mount. Your comments will help us continue to bring you quality products.

4 Mount Installation

MAN0041 (Rev. 4/4/2008)

Install Right and Left Rear Mounts

1. Attach right rear mount (1) to tractor.
2. Secure using one cap screw (7) and hardened flat washer (9) in the top hole.
3. Secure to bottom holes using two cap screws (8) and hardened flat washers (9).
4. Secure to forward holes using two cap screws (5) and hardened flat washers (9).
5. Repeat steps to install left rear mount (2). See Figure 2.
6. Tighten all hardware to specifications listed on page 6.

1. 1000468 Right rear mount
2. 1000469 Left rear mount
5. 307553 M20 x 2.5P x 50 mm HHCS
7. 1001377 M20 x 2.5P x 40 mm HHCS
8. 21413 M20 x 2.5P x 70 mm HHCS
9. 57798 3/4 Hardened flat washer.

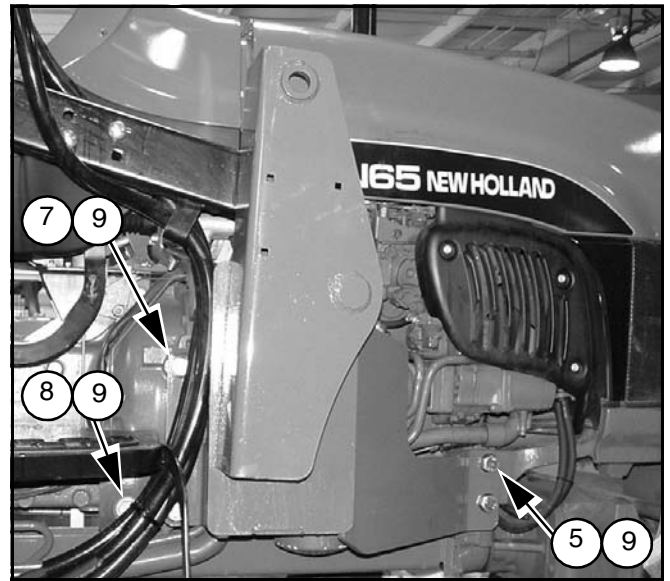

Figure 1. Right Rear Mount Installed

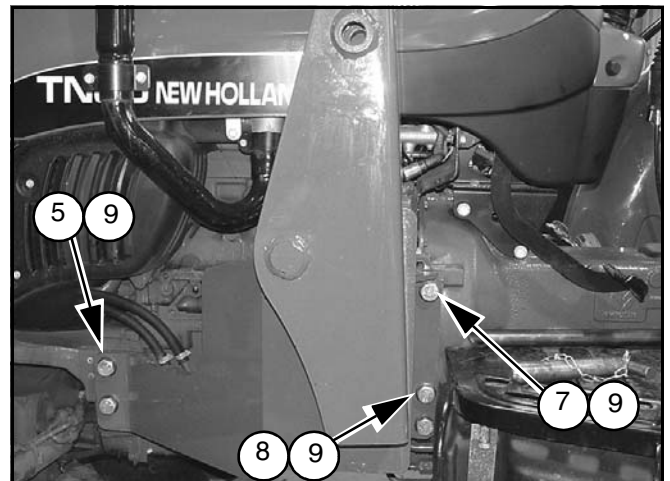

Figure 2. Left Rear Mount Installed

Install Grill Guard (Optional)

1. Install grill guard (4) to front of tractor chassis, using four cap screws (5) and lock washers (6) as shown.
2. Torque hardware to specifications given on page 6.

4. 40449 Grill guard
5. 307553 M20 x 2.5P x 50 mm HHCS
6. 21531 M20 Lock washer

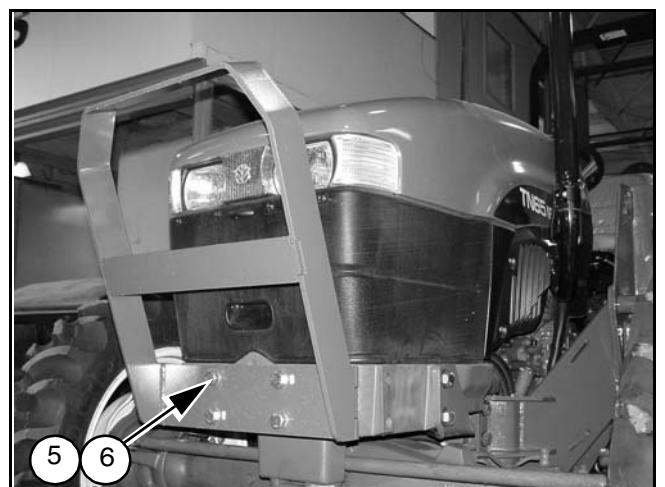

Figure 3. Grill Guard Installed

Torque Hardware

Torque all hardware to specifications listed below.

NOTICE

- Check torque value of mount hardware after 10 hours of operation and again after every 50 hours of operation.

TORQUE SPECIFICATIONS

Ref.	Cap Screw	Qty	Wrench Size	Required Torque
7	M20 x 2.5P x 40 mm	2	30 mm	244 lbs-ft. (330 N-m)
5	M20 x 2.5P x 50 mm	8	30 mm	244 lbs-ft. (330 N-m)
8	M20 x 2.5P x 70 mm	4	30 mm	244 lbs-ft. (330 N-m)

Install Weather Cap on Exhaust Pipe

NOTE: After the hydraulics and loader are install on the tractor, check the clearance between the top of the exhaust pipe and the loader boom when the loader is raised. If there is interference, a weather cap will need to be installed.

1. Remove exhaust pipe from the tractor. Save hardware for later use.
2. Remove approximately 6-inches from the top of the exhaust pipe.
3. Attach exhaust pipe to the tractor. Make sure that the support flange on the exhaust pipe is between the tractor and the support bracket as shown in page 6. Secure using hardware previously removed.
4. Attach weather cap to the top of the exhaust pipe with supplied hardware. Position cap hinge to the rear. See Figure 5. Weather cap is included in the loader mount kit.

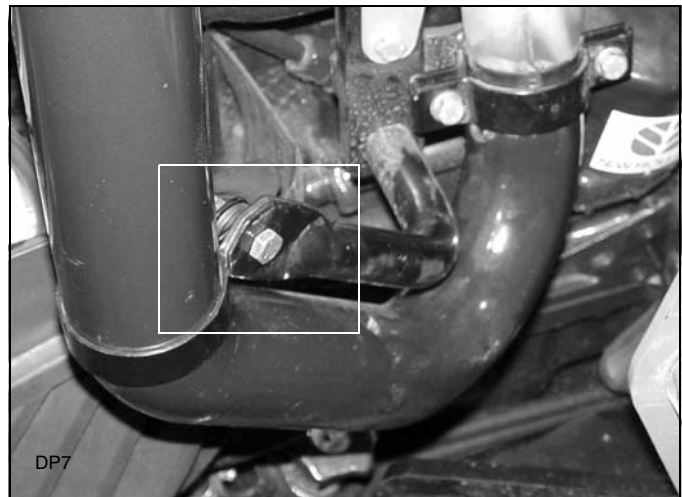

Figure 4. Exhaust Pipe Reinstalled

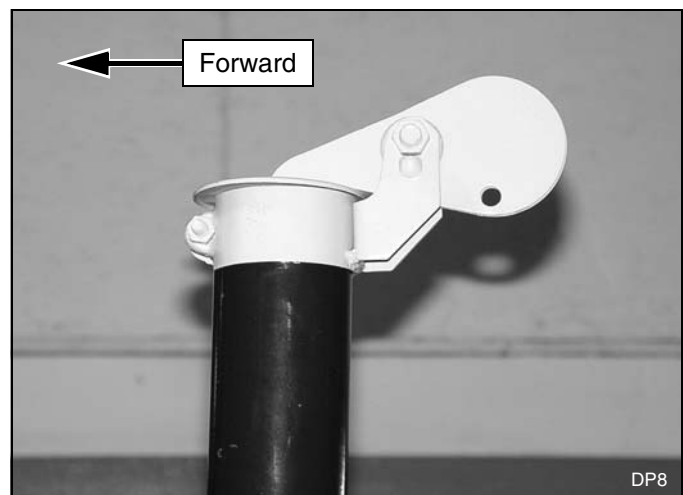

Figure 5. Weather Cap Installed

HOSE KIT INSTALLATION

WARNING

■ Keep hands and body away from pressurized lines. Use paper or cardboard, not hands or other body parts to check for leaks. Wear safety goggles. Hydraulic fluid under pressure can easily penetrate skin and will cause serious injury or death.

■ Make sure that all operating and service personnel know that if hydraulic fluid penetrates skin, it must be surgically removed as soon as possible by a doctor familiar with this form of injury or gangrene, serious injury, or death will result. **CONTACT A PHYSICIAN IMMEDIATELY IF FLUID ENTERS SKIN OR EYES. DO NOT DELAY.**

■ Air in hydraulic systems can cause erratic operation and allows loads or equipment components to drop unexpectedly. When connecting equipment or hoses or performing any hydraulic maintenance, purge any air in hydraulic system by operating all hydraulic functions several times. Do this before putting into service or allowing anyone to approach the equipment.

WARNING

■ Protective hose sleeves must cover all hydraulic hoses within 20 inches of the operator and be secured onto metal hose fittings. Replace hoses or sleeves if damaged or if protective sleeve cannot be properly positioned or secured.

■ Make sure all hydraulic hoses, fittings, and valves are in good condition and not leaking before starting power unit or using equipment. Check and route hoses carefully to prevent damage. Hoses must not be twisted, bent sharply, kinked, frayed, pinched, or come into contact with any moving parts. Operate moveable components through full operational range to check clearances. Replace any damaged hoses immediately.

58025 Hose Kit Installation ----- Page 7

46945 Hose Kit Installation----- Page 11

1010460 Hose Kit Installation----- Page 16

1023577 Hose Kit Installation----- Page 19

1023584 Hose Kit Installation----- Page 22

1023583 Hose Kit Installation----- Page 24

58025 HOSE KIT

General Description

These set up instructions are for operating the 1020, 1027 loader using the tractor hydraulic remote control levers. To use this hydraulic connection the tractor must be equipped with either two hydraulic levers or a joystick control and four tractor hydraulic couplers as shown (Figure 5).

Hydraulic quick couplers for connection to tractor are NOT INCLUDED with hose kits, but are available as service parts.

NOTE: After the hydraulics and loader are installed on the tractor, check the clearance between the top of the exhaust pipe and the loader boom when the loader is raised. If there is interference, a weather cap will need to be installed. See Page 6 for installation instructions.

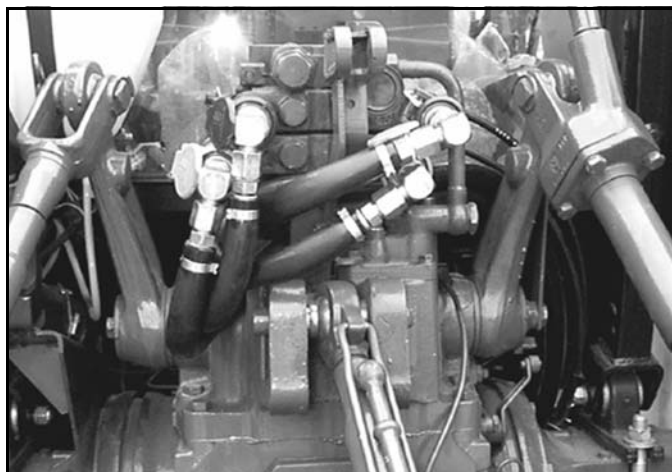

Figure 6. Connections to Tractor Hydraulic Couplers (Typical)

Assemble and Route Hoses

1. Attach a 90-degree elbow (2) and male quick coupler (3) to each loader supply hose (1).
2. Connect loader supply hoses to loader feedlines as shown in Figure 7.
3. Route hydraulic hoses along loader mount, under the right side of operator's platform, and over the rear axle. See Figure 8.

NOTE: Hoses must be routed so that they are not pinched, bent sharply, or chafed during operation. Hoses must not interfere with any tractor control operation or contact any moving parts.

1. 53670 Hose, 150" x 3/4 JICM x 3/4 JICM
2. 313053 Elbow, 3/4 JICF x 1/2 NPTM 90°
3. ----- Quick coupler, Male (not supplied)

- A - BUCKET CYL. BASE END (DUMP) - RED
- B - BUCKET CYL. ROD END (ROLLBACK) - BLUE
- C - BOOM CYL. ROD END (DOWN) - YELLOW
- D - BOOM CYL. BASE END (UP) - GREEN

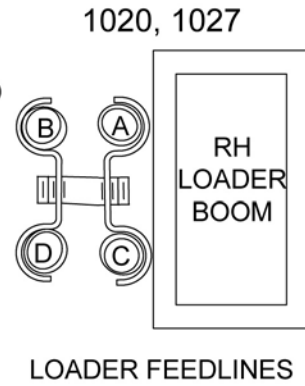

Figure 7. Loader Feedline Connection



Figure 8. Hose Routing (Typical Installation)

58025 Hose Kit

Connect Hoses to Tractor

1. Connect hoses to the tractor hydraulic couplers as shown in Figure 9.

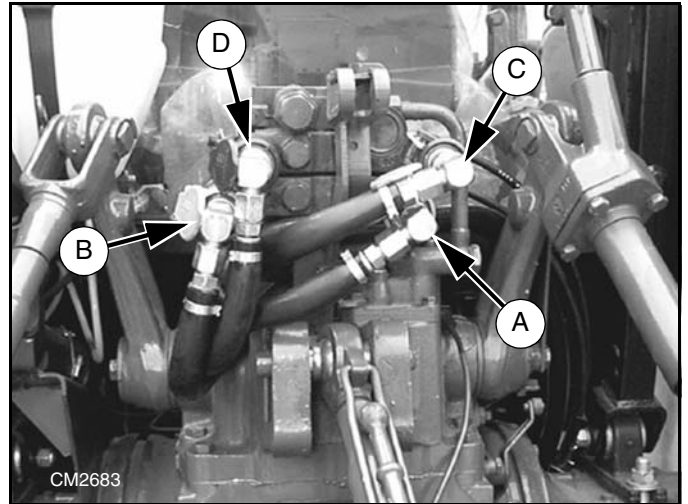

Figure 9. Hose Connection to Tractor Hydraulic Couplers (Typical)

Install Hose Hangers

1. Install hose hangers beneath the tractor chassis.

NOTE: For forward hanger, use hardware provided in kit; for rearward hanger, use tractor hardware.

2. Route hoses through hose hangers as shown and attach lock pins to retain hoses.
3. Torque hardware to 15 lbs.-ft.

6. 30577 M8 x 1.25P x 25 mm HHCS
7. 2472 5/16 Lock washer
8. 58033 Hose hanger
9. 58047 1/4 x 2-1/2 Lock pin

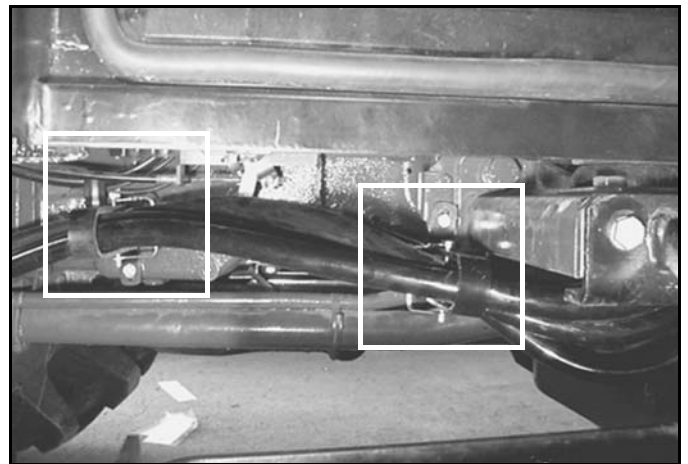

Figure 10. Hose Hangers Installed

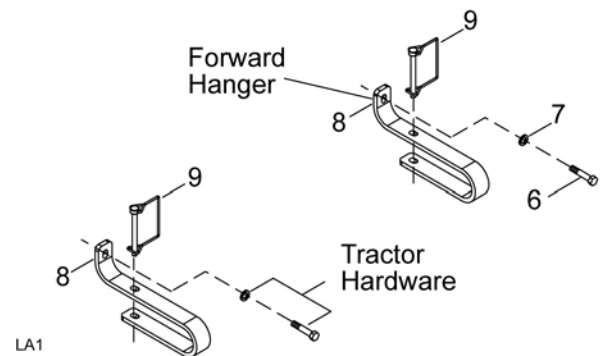
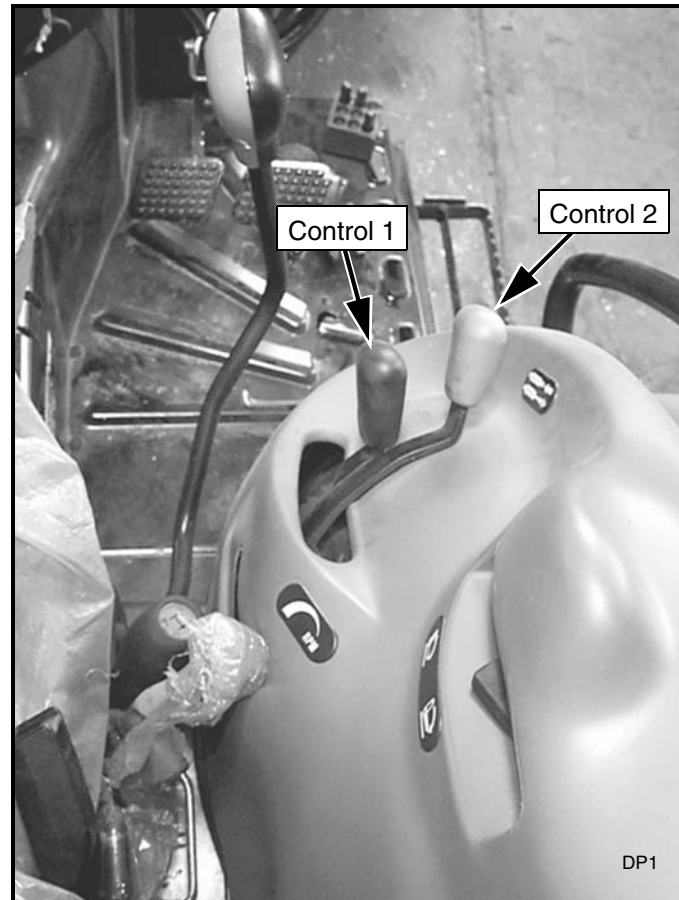

Figure 11. Hose Hanger Installation

Verify Control Movements

1. **Mount loader to tractor:** Remove mount pins from loader uprights. Align tractor with loader and slowly drive tractor into loader. Shut off tractor.
2. Connect loader feedline hoses to tractor remote control couplers. See Figure 9.
3. Comply with all safety rules and start the tractor.
4. Mount loader to tractor by activating bucket cylinders to raise or lower the loader uprights into the loader mounts. Slowly advance tractor forward, activating appropriate cylinders to engage loader completely into mounts. Insert mounting pins to secure loader.
5. Check that all hydraulic control lever positions operate the loader movements correctly as shown in Figure 12.
6. If loader movements do not respond correctly, shut off tractor, relieve pressure, and reconnect properly. Loader control movements must be correct before proceeding.
7. Once all loader functions are correct, start the tractor and operate the loader to check for leaks. Purge any remaining air from the hydraulic system and check oil level.
8. When hose routings and correct loader operations are verified, identify each circuit by placing a matching colored band around the male and female quick couplers. The color-coded bands will make reinstallation easier when the loader is removed from tractor.
9. Be sure that adequate slack is left in the hoses so they can move as the loader moves through its full range of motion.
10. Attach the plastic tie straps (included in kit) every 20-inches around the hoses to keep them tightly bundled and away from contact with the ground or other moving parts on the tractor or loader.
11. Before operating the loader, make sure that the Pre-Delivery, Delivery, and Pre-Operation Checklists from the Operator section in the Loader Operator's Manual have been completed.



- Control 1, Handle forward - Boom down
- Control 1, Handle back - Boom up
- Control 2, Handle forward - Dump bucket or attachment
- Control 2, Handle back - Rollback bucket or attachment

Figure 12. Tractor Hydraulic Control Levers

46945 HOSE KIT

General Description

These set up instructions are for operating the 1020, 1027 loader using single lever control valve mounted to the loader rear mount as shown in Figure 13. To use this hydraulic connection the hoses must be connected between the control valve and the tractor hydraulic system located at the rear of the tractor.

NOTE: After the hydraulics and loader are install on the tractor, check the clearance between the top of the exhaust pipe and the loader boom when the loader is raised. If there is interference, a weather cap will need to be installed. See Page 6 for installation instructions.

NOTICE

■ If hydraulic lines are not connected as shown in this manual, the control valve may be damaged. A blocked outlet (RETURN) or improper hose connection will cause pressurized oil to enter the return circuit and damage the valve.



Figure 13. Control Valve Installed

Adjust Control Valve

The control valve comes standard with two OUT ports. One at the lower left corner and one at the upper right corner. The port at the lower left is shipped with a 3/4 JICM x 7/8 O-ring adapter installed. The port at the upper right is shipped with a 7/8 O-ring plug.

Remove plug installed in the upper right port. Remove adapter from lower left port. Install plug in lower left port and adapter in upper right port. Control valve should have IN, OUT and PBY ports arranged as shown in Figure 14.

Attach control valve and bracket to loader mount before proceeding.

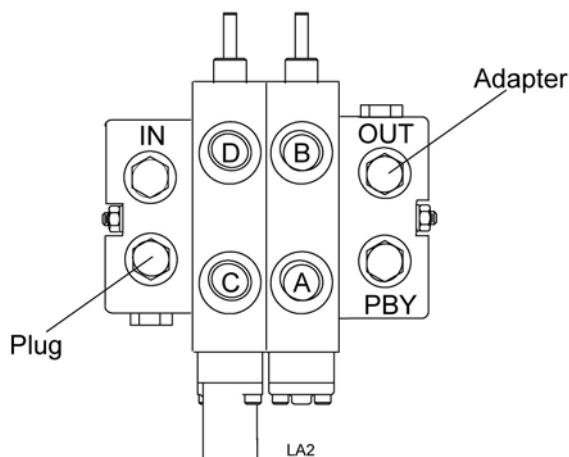

Figure 14. Correct Control Valve Arrangement

Install Hose Guide

1. Attach hose guide (7) to the outer hole on the bracket in front to the brake peddle.
2. Secure into place using cap screw (8) as shown in Figure 15. Torque to 30 lbs.-ft. using a 16mm wrench.

7. 54305 Hose guide
8. 307203 M10 x 1.25P x 35 mm HHCS

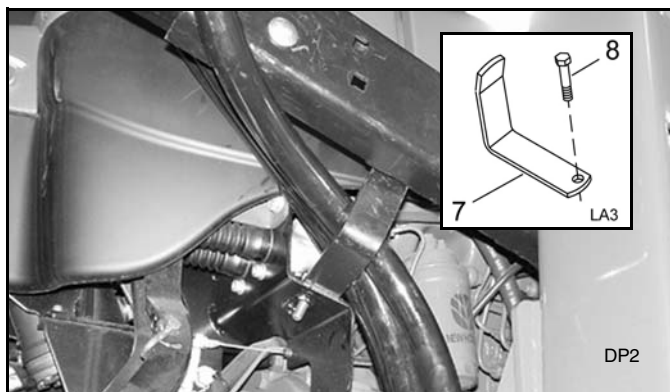

Figure 15. Hose Guide Installed

Attach Hoses to Control Valve

NOTICE

■ If hydraulic lines are not connected as shown in the mount installation manual or tractor manual, the loader control valve may be damaged. A blocked outlet (RETURN) or improper hose connection will cause pressurized oil to enter the return circuit and damage the valve or the tractor hydraulic system.

1. Attach 90° end of hoses (2) to the IN, OUT, and PBY ports on the control valve.
2. Route hoses over hose guide (as shown in Figure 15), under right side of platform, and over right rear axle.

2. 46947 Hose, 120" x 3/4 JICF x 7/8 JICF

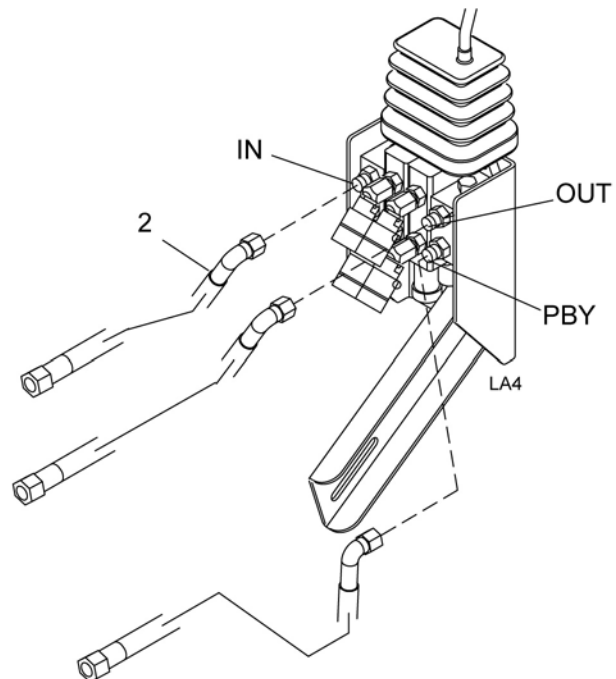

Figure 16. Control Valve Hose Connections

Install Hydraulic Fittings and Hoses

1. Locate the hydraulic ports on the rear of the tractor as shown in Figure 17.
2. Remove tube and fittings from the PBY, PRESSURE, and RETURN ports.

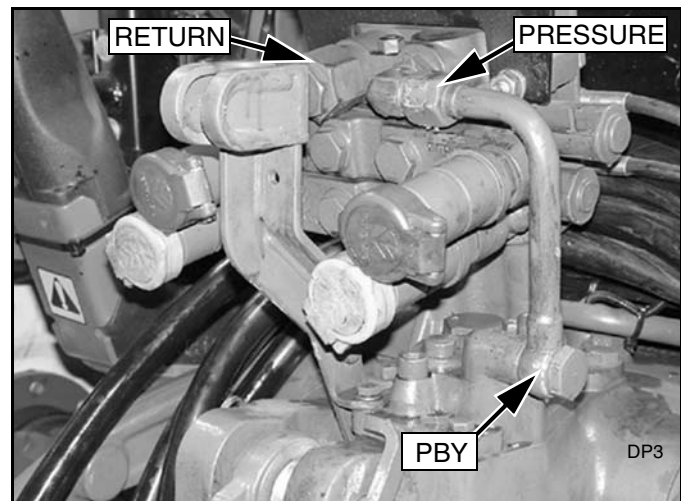

Figure 17. Tractor Hydraulic Connections

46945 Hose Kit

Install Hydraulic Fitting and Hoses (Continued)

3. Install adapter (3) and elbow (5) to the RETURN port.
4. Install elbow (6) to the PRESSURE port.
5. Install adapter (4) and elbow (5) to the PBY port.
6. Attach hose from the IN port on the control valve to elbow (6) in the PRESSURE port on the tractor.
7. Attach hose from the PBY port on the control valve to elbow (5) in the PBY port on the tractor.
8. Attach the hose from the OUT port on the control valve to elbow (5) in the RETURN port on the tractor.
9. Position the hoses as shown in Figure 19.

3. 58081 Adapter, M22 x 1.5P x 7/8 JICM
4. 58647 Adapter, M18 x 1.5P x 7/8 JICM
5. 315024 Elbow, 7/8 JICM x 7/8 JICF
6. 46054 Elbow, 7/8 JICF x 7/8 JICF 45°

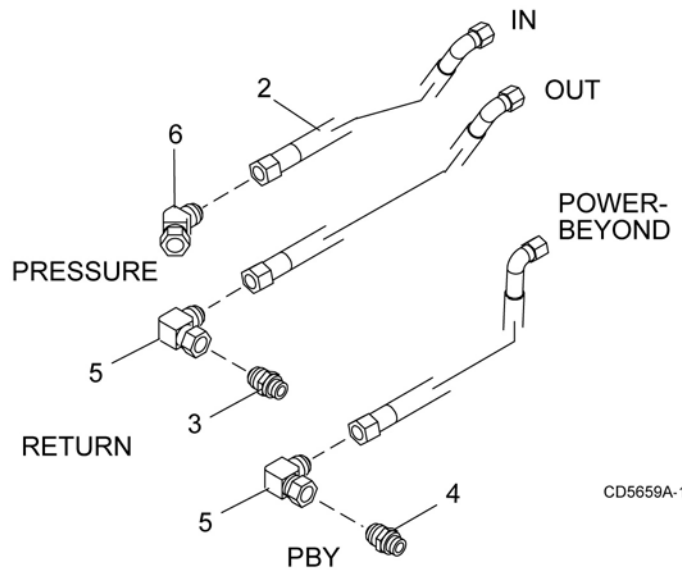

Figure 18. Hydraulic Fitting and Hose Installation

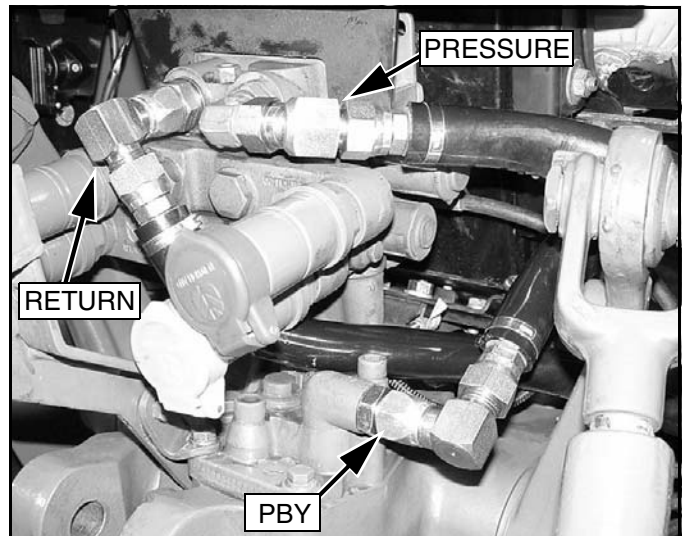

Figure 19. Hydraulic Fittings and Hoses Installed

46945 Hose Kit

Install Hose Hanger

1. Remove lower bolt, washers, and nut that secures right fender to the ROPS.
2. Keep larger washer and discard the remaining hardware.
3. Attach hose hanger (9), using spacer (10), cap screw (12), flat washer (from tractor), lock washer (13), and nut (14) as shown in Figure 20 and Figure 21.
4. Route PRESSURE and PBY hoses through hanger as shown in Figure 21.
5. Secure hoses into position using lock pin (11).
6. Route RETURN hose as shown in Figure 19 to avoid upper 3-point arms.
7. Tighten all hydraulic fittings securely.

- | | | |
|-----|-------|---------------------|
| 9. | 58280 | Hose hanger |
| 10. | 46948 | Spacer |
| 11. | 58047 | Lock pin |
| 12. | 31138 | 3/8 NC x 3-1/2 HHCS |
| 13. | 838 | 3/8 Lock washer |
| 14. | 835 | 3/8 NC Hex nut |

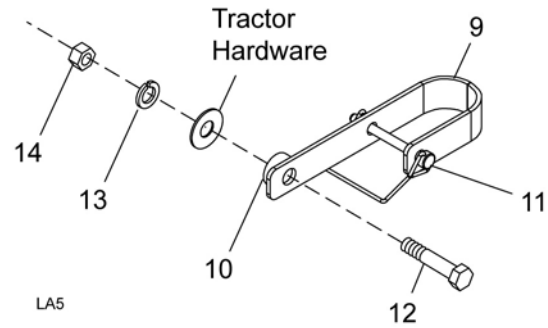

Figure 20. Hose Hanger Installation

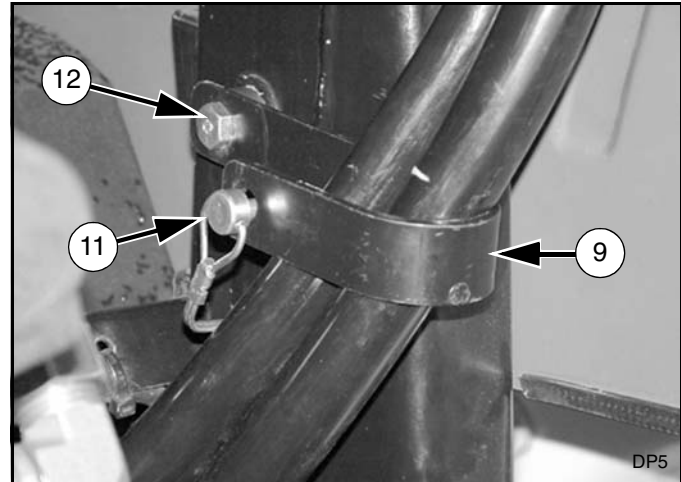
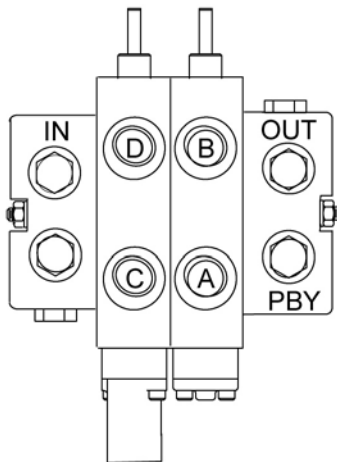

Figure 21. Hose Hanger Installed

Connect Work Port Hoses

1. The control valve kit contains hoses assembled with quick couplers. Attach supply hoses to loader feedlines, following the color scheme shown in Figure 22.
2. Connect loader supply hoses to control valve hydraulic couplers when attaching loader.



2 - Spool Control Valve

- | | |
|-----|---------------------------------------|
| A - | BUCKET CYL. BASE END (DUMP) - RED |
| B - | BUCKET CYL. ROD END (ROLLBACK) - BLUE |
| C - | BOOM CYL. ROD END (DOWN) - YELLOW |
| D - | BOOM CYL. BASE END (UP) - GREEN |

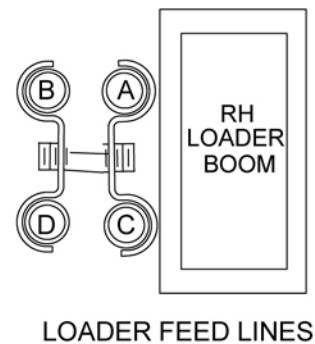

Figure 22. 1020, 1027 Control Valve and Loader Feedline Hose Connections

Verification of Control Movements

1. **Mount loader to tractor:** Remove mount pins from loader uprights. Align tractor with loader and lowly drive tractor into loader. Shut off tractor.

2. Connect loader feedline hoses to control valve hydraulic couplers (See Figure 22).

NOTE: At least 6" spacing should be maintained between valve, bracket, or hoses and any tractor control (brake pedals, accelerator, hand throttle, or hydraulic levers).

3. Comply with all Safety Rules and start the tractor.

4. Mount loader to tractor by activating bucket cylinders to raise or lower the loader uprights into the loader mounts. Slowly advance tractor forward, activating appropriate cylinders to engage loader completely into mounts. Insert mounting pins to secure loader.

5. Check that all hydraulic control lever positions operate the loader movements correctly as shown in Figure 23.

6. If loader movements do not respond correctly, shut off tractor, relieve pressure, and reconnect properly. Loader control movements must be correct before proceeding.

7. Once all loader functions are correct, start the tractor and operate the loader to check for leaks. Purge any remaining air from the hydraulic system.

8. When hose routings and correct loader operations are verified, identify each circuit by placing a matching colored band around the male and female quick-disconnect coupler set. The colored bands will make re-installation easier when the loader is remove from the tractor.

9. Be sure the adequate slack is left in the hoses so they can move as the loader moves through its full range of motion.

10. Attach plastic tie straps every 20" around the hoses to keep them tightly bound and away from contact with the ground or other moving parts on tractor.

11. Before operating the loader, make sure that the Pre-Delivery, Delivery, and Pre-Operation Checklists from the Operation section in the Loader Operator's Manual have been completed.

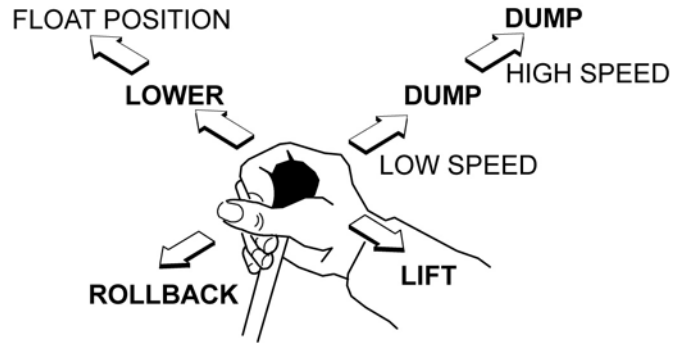

- Handle forward - Boom down
- Handle forward to limit - Float position
- Handle back - Boom up
- Handle right - Dump bucket or attachment (slow)
- Handle right to limit - Dump bucket or attachment (fast)
- Handle to left - Rollback bucket or attachment

Figure 23. Single Lever Control Operation

1010460 HOSE KIT

General Description

These set-up instructions are for operating the 1020, 1027 loader using the tractor hydraulic remote control lever. To use this hydraulic connection, the tractor must be equipped with a multi-function hydraulic control valve and remote control lever. The control valve is located on the right side of the tractor beneath the operator platform.

NOTE: After the hydraulics and loader are installed on the tractor, check the clearance between the top of the exhaust pipe and the loader boom when the loader is raised. If there is interference, a weather cap will need to be installed. See Page 6 for installation instructions.



Figure 24. Tractor Hydraulic Control Lever and Valve

Install Hydraulic Fitting to Tractor Valve

1. Locate the tractor hydraulic valve under the right side of the tractor platform.
2. Install adapters (1), adapter (3), and female half of quick coupler set (5) to each of the tractor valve ports. See Figure 7 and Figure 8.

NOTE: Not all parts supplied with this hose kit are used for this application.

1. 1010920 Adapter, M22 x 1.5 x 3/4 JICM
3. 315036 Adapter, 3/8 NPTM x 3/4 JICF
5. 316007 Quick coupler set, male & female

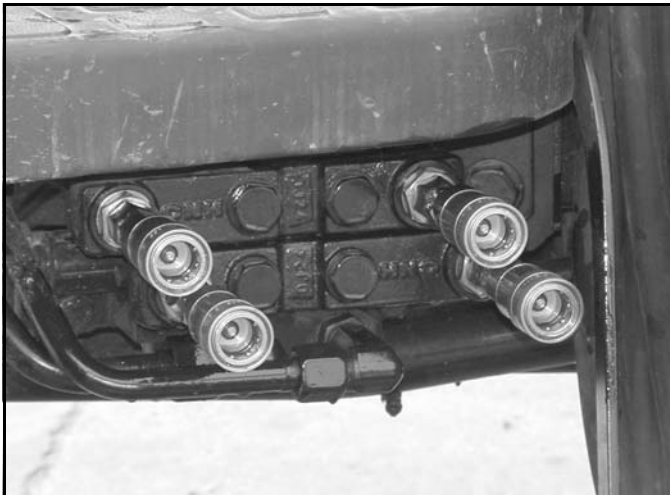

Figure 25. Hydraulic Fittings Installed

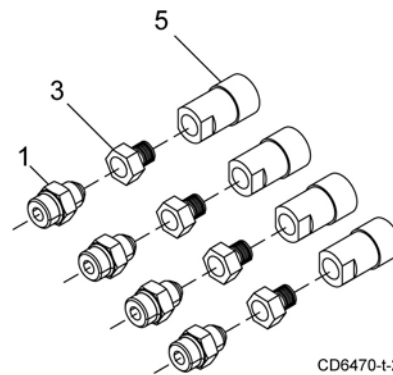

Figure 26. Hydraulic Fitting Installation

CD6470-t-2

1010460 Hose Kit

Assemble Loader Hoses

1. Attach male half of quick coupler set (5) and elbow (2) to each of the loader feedline hoses (4). See Figure 27.
2. Attach loader feedline hoses to the steel feedlines on the loader boom. See Figure 28.
3. Route hydraulic hoses along loader mount and under the right side of operator's platform to the tractor valve.

NOTE: Be sure to avoid contact with brake pedals and other moveable tractor components. Hoses must be routed so that they are not pinched, bent sharply, or chafed during operation. Hoses must not interfere with any tractor control operation or contact any moving parts.

2. 313015 Elbow, 3/8 NPTM x 3/8 NPTF 45°
4. 1009513 Hose, 76" x 3/8 NPTM x 3/4 JICM
5. 316007 Quick coupler set, male & female

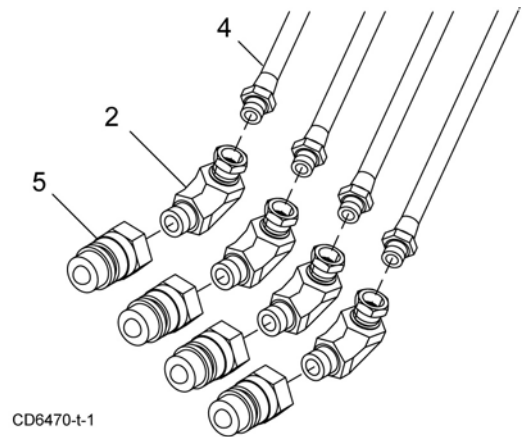

Figure 27. Loader Hose Connection

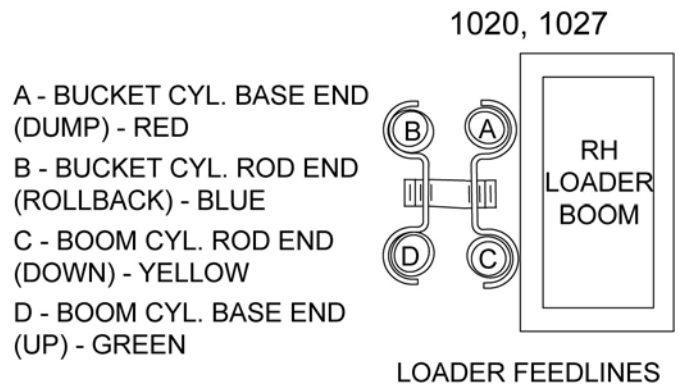

Figure 28. Loader Feedline Connection

Connect Hoses to Tractor Valve

Connect hoses to the hydraulic quick couplers as shown in Figure 29.

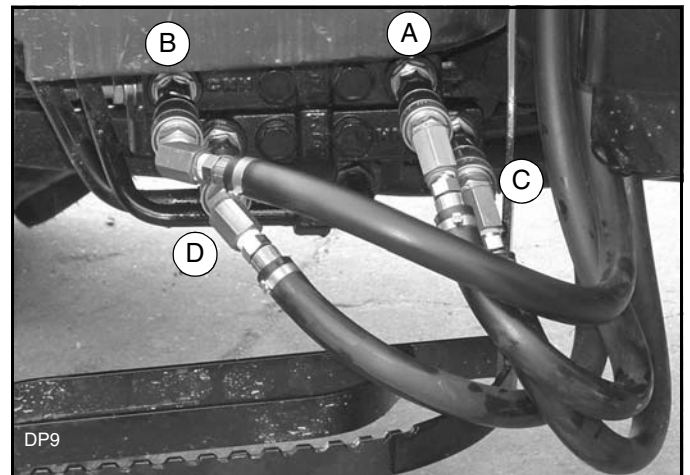

Figure 29. Hydraulic Hose Connection to Tractor Valve

Verification of Control Movements

1. **Mount loader to tractor:** Remove mount pins from loader uprights. Align tractor with loader and lowly drive tractor into loader. Shut off tractor.

2. Connect loader feedline hoses to control valve hydraulic couplers (See Figure 29).

NOTE: At least 6" spacing should be maintained between valve, bracket, or hoses and any tractor control (brake pedals, accelerator, hand throttle, or hydraulic levers).

3. Comply with all Safety Rules and start the tractor.

4. Mount loader to tractor by activating bucket cylinders to raise or lower the loader uprights into the loader mounts. Slowly advance tractor forward, activating appropriate cylinders to engage loader completely into mounts. Insert mounting pins to secure loader.

5. Check that all hydraulic control lever positions operate the loader movements correctly as shown in Figure 30.

6. If loader movements do not respond correctly, shut off tractor, relieve pressure, and reconnect properly. Loader control movements must be correct before proceeding.

7. Once all loader functions are correct, start the tractor and operate the loader to check for leaks. Purge any remaining air from the hydraulic system.

8. When hose routings and correct loader operations are verified, identify each circuit by placing a matching colored band around the male and female quick-disconnect coupler set. The colored bands will make re-installation easier when the loader is remove from the tractor.

9. Be sure the adequate slack is left in the hoses so they can move as the loader moves through its full range of motion.

10. Attach plastic tie straps every 20" around the hoses to keep them tightly bound and away from contact with the ground or other moving parts on tractor.

11. Before operating the loader, make sure that the Pre-Delivery, Delivery, and Pre-Operation Checklists from the Operation section in the Loader Operator's Manual have been completed.

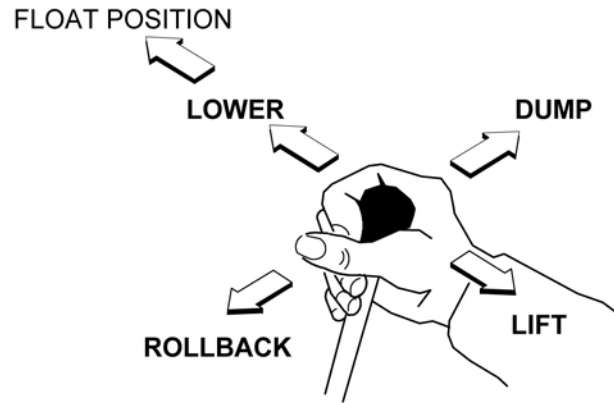

- Handle forward - Boom down
- Handle forward to limit - Float position
- Handle back - Boom up
- Handle right - Dump bucket or attachment
- Handle to left - Rollback bucket or attachment

Figure 30. Single Lever Control Operation

1023577 HOSE KIT

General Description

These set-up instructions are for operating the LU126 or LU132 loader using the tractor hydraulic remote control lever. To use this hydraulic connection, the tractor must be equipped with a multi-function hydraulic control valve and remote control lever. The control valve is located on the right side of the tractor beneath the operator platform.



Figure 31. Tractor Remote Control Lever

Install Hydraulic Fitting to Tractor Valve

1. Locate the tractor hydraulic valve under the right side of the tractor platform.
2. Install adapters (1), adapter (3), and female half of quick coupler set (5) to each of the tractor valve ports. See Figure 32 and Figure 33.

NOTE: Not all parts supplied with this hose kit are used for this application.

1. 1010920 Adapter, M22 x 1.5 x 3/4 JICM
3. 315036 Adapter, 3/8 NPTM x 3/4 JICF
5. 316007 Quick coupler set, male & female

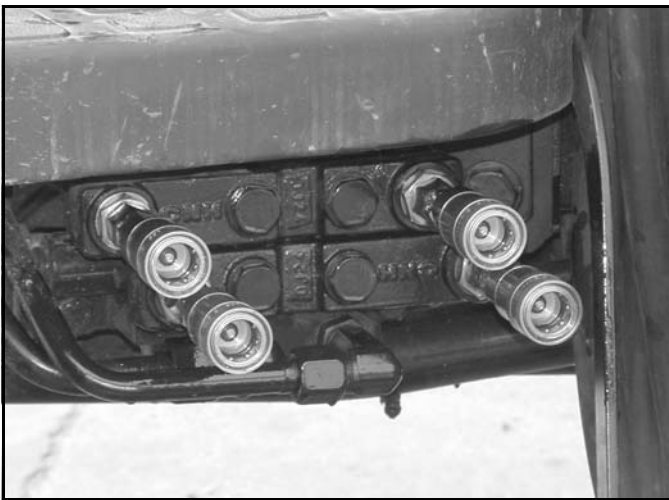

Figure 32. Hydraulic Fittings Installed

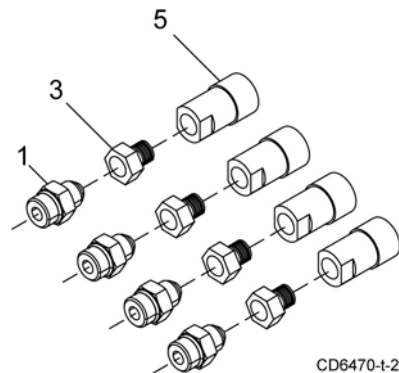

Figure 33. Hydraulic Fitting Installation

1023577 Hose Kit

Assemble Loader Hoses

1. Attach male half of quick coupler set (5) and elbow (2) to each of the loader feedline hoses (4). See Figure 34
2. Attach loader feedline hoses to the steel feedlines on the loader boom. See Figure 35.
3. Route hydraulic hoses along loader mount and under the right side of operator's platform to the tractor valve.

NOTE: Be sure to avoid contact with brake pedals and other moveable tractor components. Hoses must be routed so that they are not pinched, bent sharply, or chafed during operation. Hoses must not interfere with any tractor control operation or contact any moving parts.

2. 313015 Elbow, 3/8 NPTM x 3/8 NPTF 45°
4. 1022986 Hose, 116" x 3/8 NPTM x 3/4 JICM
5. 316007 Quick coupler set, male & female

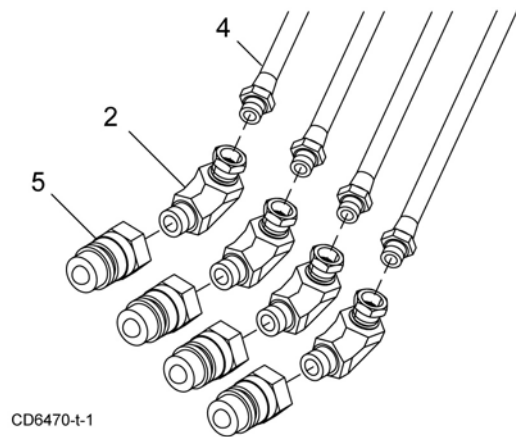

Figure 34. Loader Hose Connection

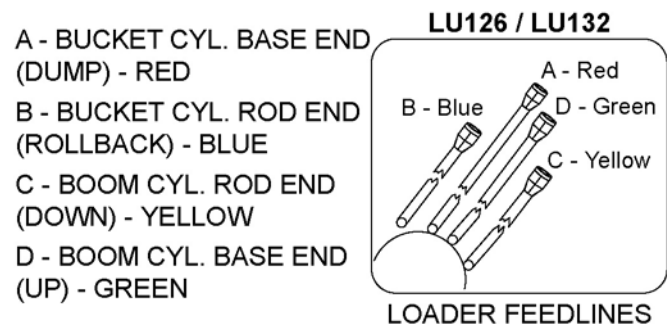

Figure 35. Loader Feedline Connection

Connect Hoses to Tractor Valve

Connect hoses to the hydraulic quick couplers as shown in Figure 36.

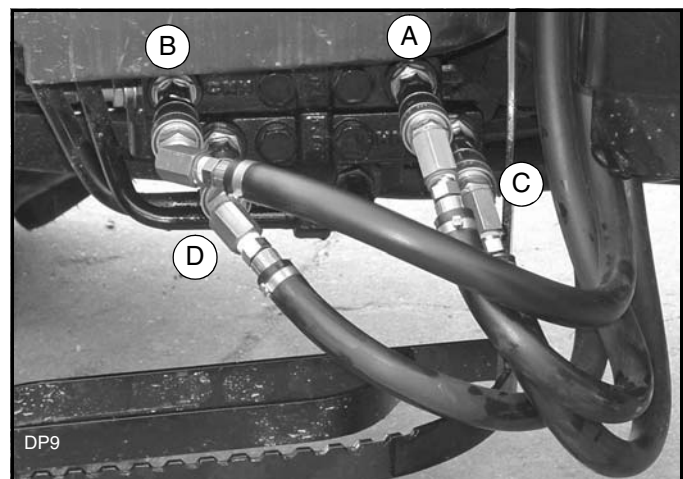

Figure 36. Hydraulic Hose Connection to Tractor Valve

Verification of Control Movements

1. **Mount loader to tractor:** Remove mount pins from loader uprights. Align tractor with loader and lowly drive tractor into loader. Shut off tractor.

2. Connect loader feedline hoses to control valve hydraulic couplers (See Figure 36).

NOTE: At least 6" spacing should be maintained between valve, bracket, or hoses and any tractor control (brake pedals, accelerator, hand throttle, or hydraulic levers).

3. Comply with all Safety Rules and start the tractor.

4. Mount loader to tractor by activating bucket cylinders to raise or lower the loader uprights into the loader mounts. Slowly advance tractor forward, activating appropriate cylinders to engage loader completely into mounts. Insert mounting pins to secure loader.

5. Check that all hydraulic control lever positions operate the loader movements correctly as shown in Figure 37.

6. If loader movements do not respond correctly, shut off tractor, relieve pressure, and reconnect properly. Loader control movements must be correct before proceeding.

7. Once all loader functions are correct, start the tractor and operate the loader to check for leaks. Purge any remaining air from the hydraulic system.

8. When hose routings and correct loader operations are verified, identify each circuit by placing a matching colored band around the male and female quick-disconnect coupler set. The colored bands will make re-installation easier when the loader is remove from the tractor.

9. Be sure the adequate slack is left in the hoses so they can move as the loader moves through its full range of motion.

10. Attach plastic tie straps every 20" around the hoses to keep them tightly bound and away from contact with the ground or other moving parts on tractor.

11. Before operating the loader, make sure that the Pre-Delivery, Delivery, and Pre-Operation Checklists from the Operation section in the Loader Operator's Manual have been completed.

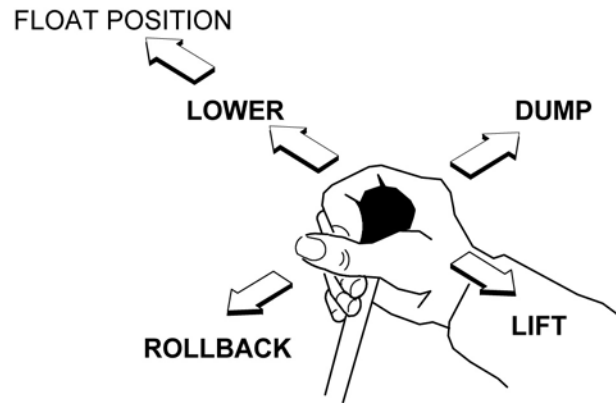

- Handle forward - Boom down
- Handle forward to limit - Float position
- Handle back - Boom up
- Handle right - Dump bucket or attachment
- Handle to left - Rollback bucket or attachment

Figure 37. Single Lever Control Operation

1023584 HOSE KIT

General Description

These set-up instructions are for operating the LU126 or LU132 loader using the tractor hydraulics. To use this connection, the tractor must be equipped with two hydraulic levers and four tractor hydraulic couplers at the rear of the tractor as shown in Figure 38.

NOTE: The male hydraulic quick couplers for connection to tractor are NOT INCLUDED with this hose kit but are available as service parts.

NOTE: After the hydraulics and loader are installed on the tractor, check the clearance between the top of the exhaust pipe and the loader boom when the loader is raised. If there is interference, a weather cap will need to be installed. See Page 6 for installation instructions.

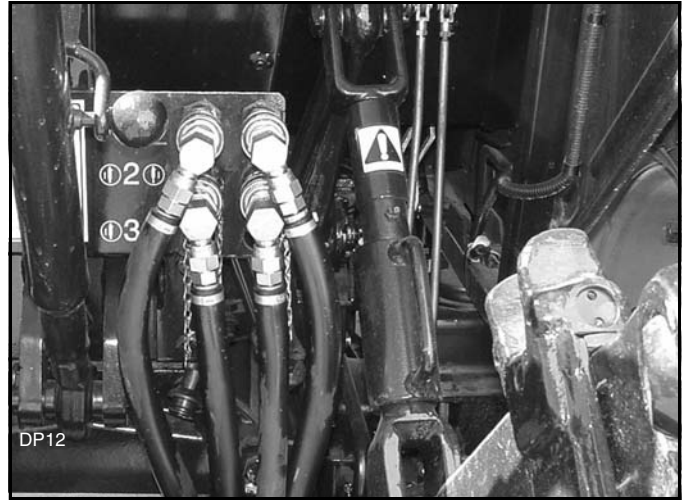

Figure 38. Tractor Rear Hydraulic Couplers (Typical)

Assemble Hoses

1. Attach a 90-degree elbow (2) and male quick coupler (3) to each loader supply hose (1). See Figure 39.
2. Connect loader supply hoses to loader feedlines as shown in Figure 40.
3. Route hoses along right mount, under the cab/operator's platform, and over right rear axle. Be sure to avoid contact with 3-point linkage, brake pedals, and other moveable tractor components. Hoses must be routed so that they are not pinched, bent sharply, or chafed during operation.

1. 1023493 Hose, 200" x 3/4 JICM x 3/4 JICM
2. 313053 Elbow, 3/4 JICF x 1/2 NPTM 90°
3. ----- Quick coupler, male (not included in kit)

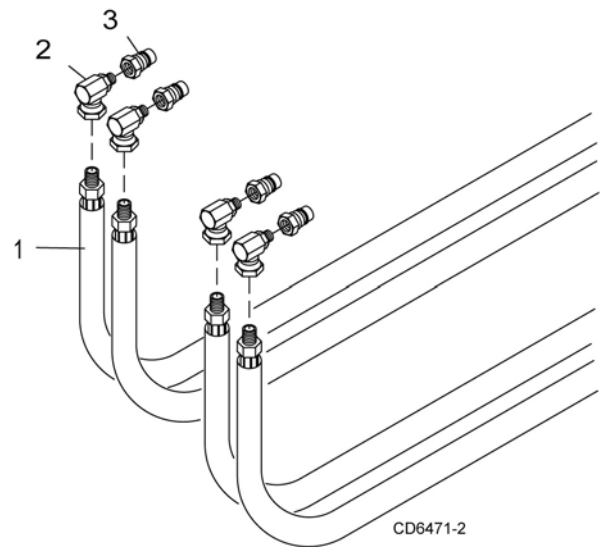

Figure 39. Hose Assembly

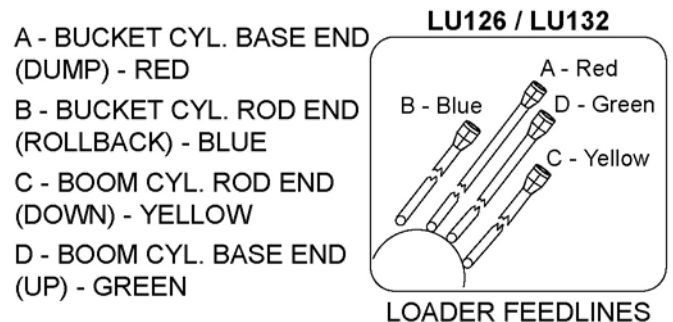

Figure 40. Loader Feedline Connections

1023584 Hose Kit

Install Hose Hanger

1. Remove a bolt from the bottom of right cab/operator's platform support.
2. Attach hose hanger (4) and secure with tractor hardware previously removed.
3. Place hoses in hose hanger when routing hydraulic hoses to the tractor hydraulic couplers.
4. Secure hoses in position using lock pin (5).

4. 59520 Hose hanger
 5. 58047 1/4 x 2-1/2 Lock pin
 * Tractor hardware

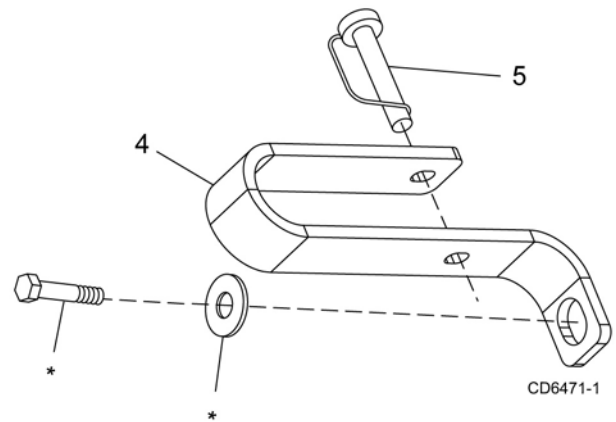
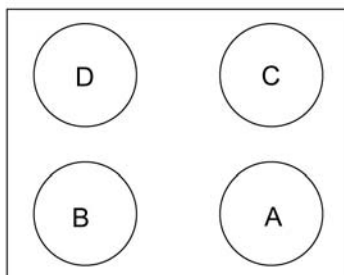

Figure 41. Hose Hanger Installation

Verify Control Movements

1. **Mount loader to tractor:** Remove mount pins from loader uprights. Align tractor with loader and slowly drive tractor into loader. Shut off tractor.
2. Connect loader feedline hoses to tractor remote control couplers. See Figure 42.
3. Comply with all safety rules and start the tractor.
4. Mount loader to tractor by activating bucket cylinders to raise or lower the loader uprights into the loader mounts. Slowly advance tractor forward, activating appropriate cylinders to engage loader completely into mounts. Insert mounting pins to secure loader.
5. Check that all tractor hydraulic control lever positions operate the loader movements correctly.
6. If loader movements do not respond correctly, shut off tractor, relieve pressure, and reconnect properly. Loader control movements must be correct before proceeding.
7. Once all loader functions are correct, start the tractor and operate the loader to check for leaks. Purge any remaining air from the hydraulic system and check oil level.
8. When hose routings and correct loader operations are verified, identify each circuit by placing a matching colored band around the male and female quick-disconnect coupler. The color-coded bands will make reinstallation easier when the loader is removed from the tractor.
9. Be sure that adequate slack is left in the hoses so they can move as the loader moves through its full range of motion.
10. Attach the plastic tie straps (included in kit) every 20-inches around the hoses to keep them tightly bundled and away from contact with the ground or other moving parts on the tractor or loader.
11. Before operating the loader, make sure that the Pre-Delivery, Delivery, and Pre-Operation Check Lists in the Loader Operator's Manual have been completed.



Tractor Remote Couplers

LA6

- A - BUCKET CYL. BASE END (DUMP) - RED
 B - BUCKET CYL. ROD END (ROLLBACK) - BLUE
 C - BOOM CYL. ROD END (DOWN) - YELLOW
 D - BOOM CYL. BASE END (UP) - GREEN

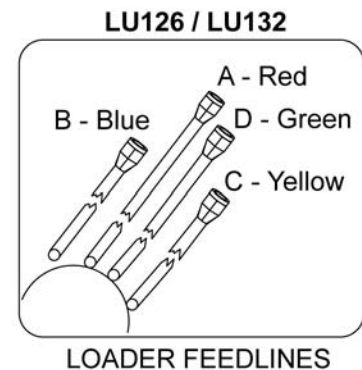

Figure 42. Loader Feedline to Tractor Remote Coupler Connections

1023583 HOSE KIT

General Description

These set up instructions are for operating the LU126 or LU132 loader using single lever control valve mounted to the right loader mount as shown in Figure 43. To use this hydraulic connection the hoses will be connected between the control valve and the tractor hydraulic system located at the rear of the tractor.

NOTE: After the hydraulics and loader are installed on the tractor, check the clearance between the top of the exhaust pipe and the loader boom when the loader is raised. If there is interference, a weather cap will need to be installed. See Page 6 for installation instructions.

NOTICE

■ If hydraulic lines are not connected as shown in this manual, the control valve may be damaged. A blocked outlet (RETURN) or improper hose connection will cause pressurized oil to enter the return circuit and damage the valve.

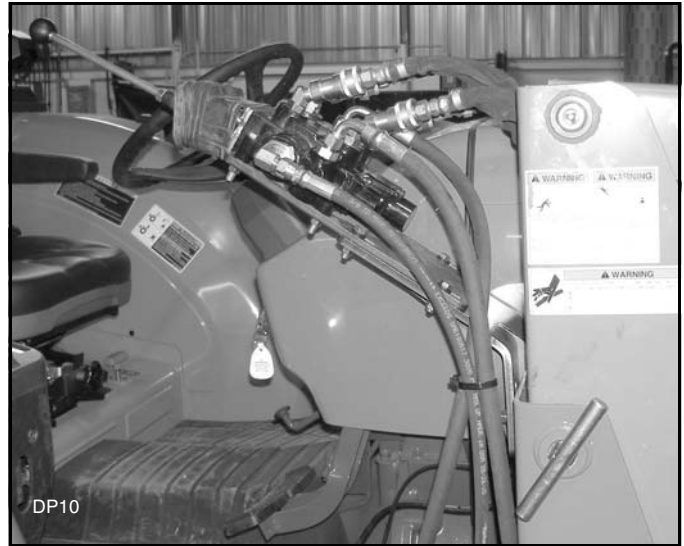

Figure 43. Control Valve Installed (Typical)

Install Hydraulic Fittings to Control Valve

1. Remove open-center plug from the side of the control valve.
2. Install PBY conversion plug (18) and elbow (17), supplied with hose kit, into the side of the control valve.
3. Attach elbow (5) to the fitting in the IN port of the control valve.

- | | | |
|-----|--------|--------------------------------|
| 5. | 313032 | Elbow, 3/4 JICM x 3/4 JICF 90° |
| 17. | 60 | Elbow, 3/4 JICM x 7/8 ORBM |
| 18. | 346143 | Power-Beyond conversion plug |

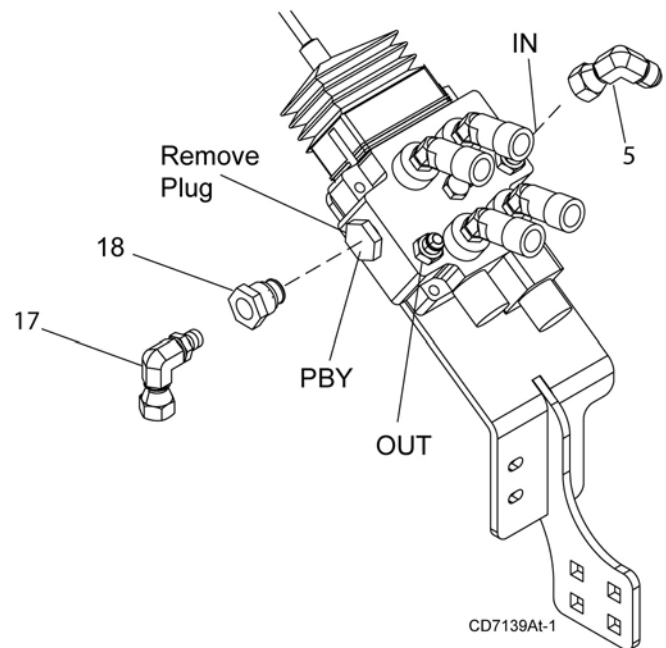

Figure 44. Cable Control Valve Fitting Installation

1023583 Hose Kit

Install Hydraulic Fittings and Hoses

1. Locate the hydraulic ports on the rear of the tractor.
2. Remove tube and fittings from the PBY, PRESSURE, and RETURN ports shown in Figure 45.
3. Install adapter (4) in the PBY port, adapter (3) and elbow (5) in the RETURN port and elbow (6) in the PRESSURE port.
4. Attach straight end of hose (1) to the PBY port on the control valve.
5. Attach 90° end of second hose (1) to the OUT port on the control valve.
6. Attach one end of hose (2) to the IN port on the control valve.
7. Route hoses under right side of platform, over right rear axle and out the back of the tractor.
8. Attach straight end of hose (1) from the OUT port on the control valve to the elbow (5) in the RETURN port on the back of the tractor.
9. Attach end of hose (2) from the IN port on the control valve to the PRESSURE port on the back of the tractor.
10. Attach 90° end of hose (1) from the PBY port on the control valve to the PBY port on the back of the tractor.

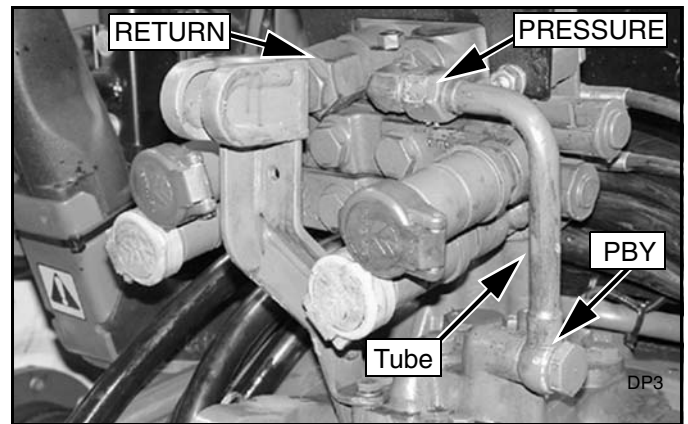

Figure 45. Tractor Hydraulic Connections

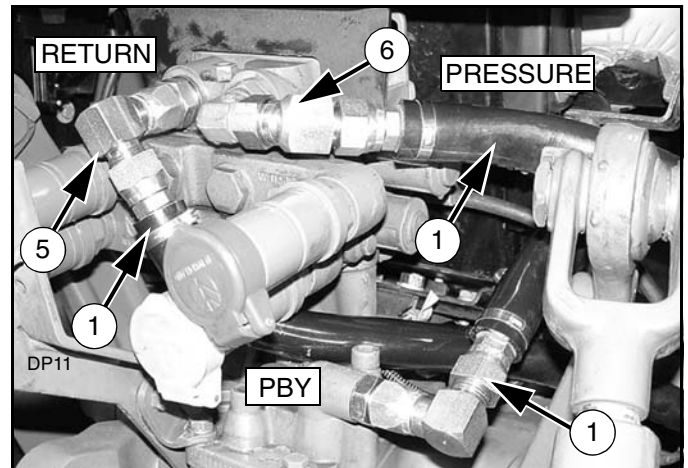

Figure 46. Hydraulic Fittings and Hose Connections

1. 1002862 Hose, 120" x 3/4 JICF x 3/4 JICF 90°
2. 1023496 Hose, 120" x 3/4 JICF x 7/8 JICF
3. 1010920 Adapter, M22 x 1.5P x 3/4 JICM
4. 44426 Adapter, M18 x 1.5P x 3/4 JICM
5. 313032 Elbow, 3/4 JICM x 3/4 JICF 90°
6. 46054 Elbow, 7/8 JICM x 7/8 JICF 45°

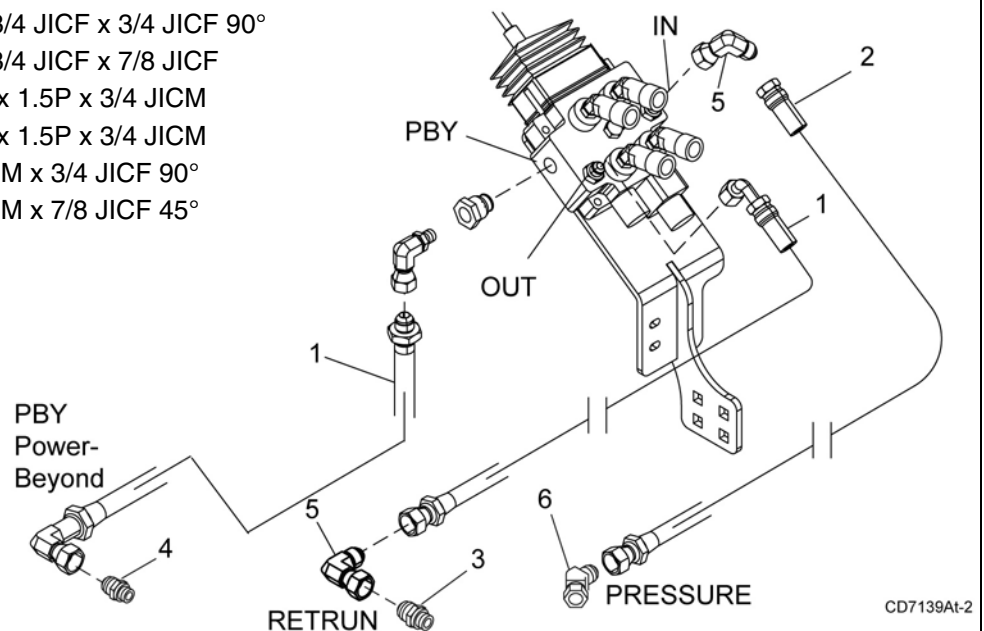

Figure 47. Hydraulic Fittings and Hose Installation

1023583 Hose Kit

Install Hose Hanger

1. Remove lower bolt, washers, and nut that secures right fender to the ROPS.
2. Keep larger washer and discard the remaining hardware.
3. Attach hose hanger (9), using spacer (10), cap screw (12), flat washer (from tractor), lock washer (13), and nut (14) as shown in Figure 48 and Figure 49.
4. Route PRESSURE and PBY hoses through hanger as shown in Figure 49.
5. Secure hoses into position using lock pin (11).
6. Tighten all hydraulic fittings securely.

- | | | |
|-----|-------|---------------------|
| 9. | 58280 | Hose hanger |
| 10. | 46948 | Spacer |
| 11. | 58047 | Lock pin |
| 12. | 31138 | 3/8 NC x 3-1/2 HHCS |
| 13. | 838 | 3/8 Lock washer |
| 14. | 835 | 3/8 NC Hex nut |

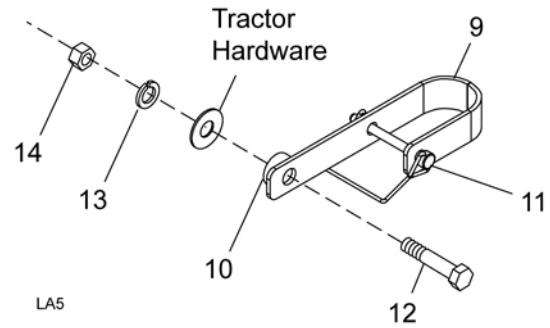

Figure 48. Hose Hanger Installation

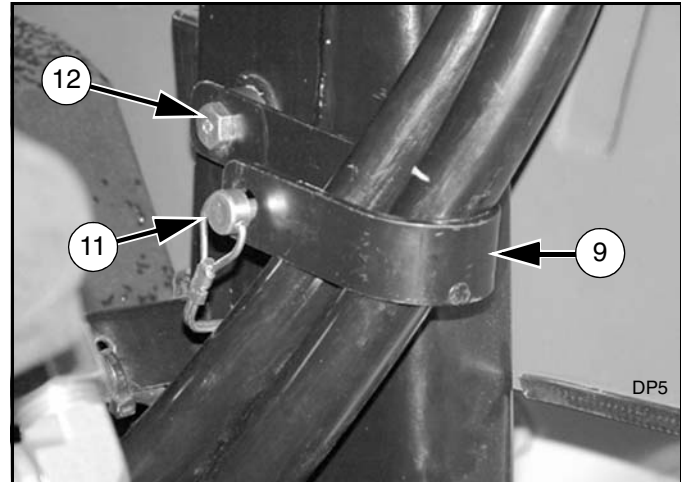
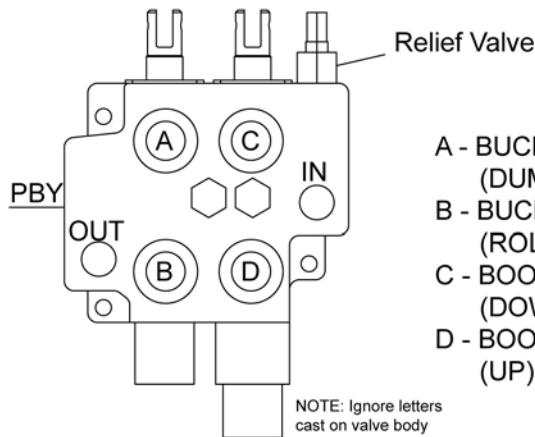

Figure 49. Hose Hanger Installed

Connect Work Port Hoses

1. The control valve kit contains hoses assembled with quick couplers. Attach supply hoses to loader feedlines, following the color scheme shown in Figure 50.
2. Connect loader supply hoses to control valve hydraulic couplers when attaching loader.



- | | |
|-----|---------------------------------------|
| A - | BUCKET CYL. BASE END (DUMP) - RED |
| B - | BUCKET CYL. ROD END (ROLLBACK) - BLUE |
| C - | BOOM CYL. ROD END (DOWN) - YELLOW |
| D - | BOOM CYL. BASE END (UP) - GREEN |

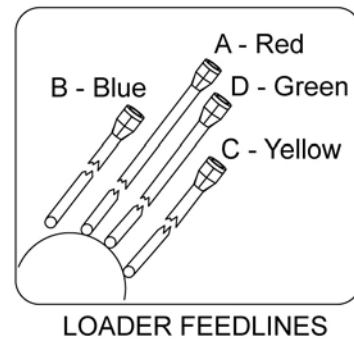
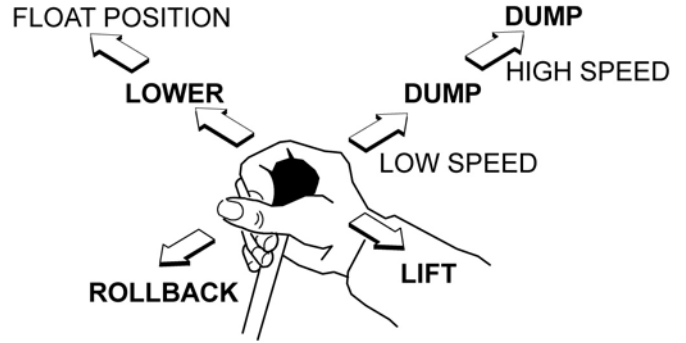

Figure 50. LU126 & LU132 Control Valve and Loader Feedline Hose Connections

Verification of Control Movements

1. **Mount loader to tractor:** Remove mount pins from loader uprights. Align tractor with loader and lowly drive tractor into loader. Shut off tractor.
2. Connect loader feedline hoses to control valve hydraulic couplers (See Figure 50).
3. Comply with all Safety Rules and start the tractor.
4. Mount loader to tractor by activating bucket cylinders to raise or lower the loader uprights into the loader mounts. Slowly advance tractor forward, activating appropriate cylinders to engage loader completely into mounts. Insert mounting pins to secure loader.
5. Check that all hydraulic control lever positions operate the loader movements correctly as shown in Figure 51.
6. If loader movements do not respond correctly, shut off tractor, relieve pressure, and reconnect properly. Loader control movements must be correct before proceeding.
7. Once all loader functions are correct, start the tractor and operate the loader to check for leaks. Purge any remaining air from the hydraulic system.
8. When hose routings and correct loader operations are verified, identify each circuit by placing a matching colored band around the male and female quick-disconnect coupler set. The colored bands will make re-installation easier when the loader is remove from the tractor.
9. Be sure the adequate slack is left in the hoses so they can move as the loader moves through its full range of motion.
10. Attach plastic tie straps every 20" around the hoses to keep them tightly bound and away from contact with the ground or other moving parts on tractor.
11. Before operating the loader, make sure that the Pre-Delivery, Delivery, and Pre-Operation Checklists from the Operation section in the Loader Operator's Manual have been completed.



- Handle forward - Boom down
- Handle forward to limit - Float position
- Handle back - Boom up
- Handle right - Dump bucket or attachment (slow)
- Handle right to limit - Dump bucket or attachment (fast)
- Handle to left - Rollback bucket or attachment

Figure 51. Single Lever Control Operation

111874 LOADER MOUNTING KIT

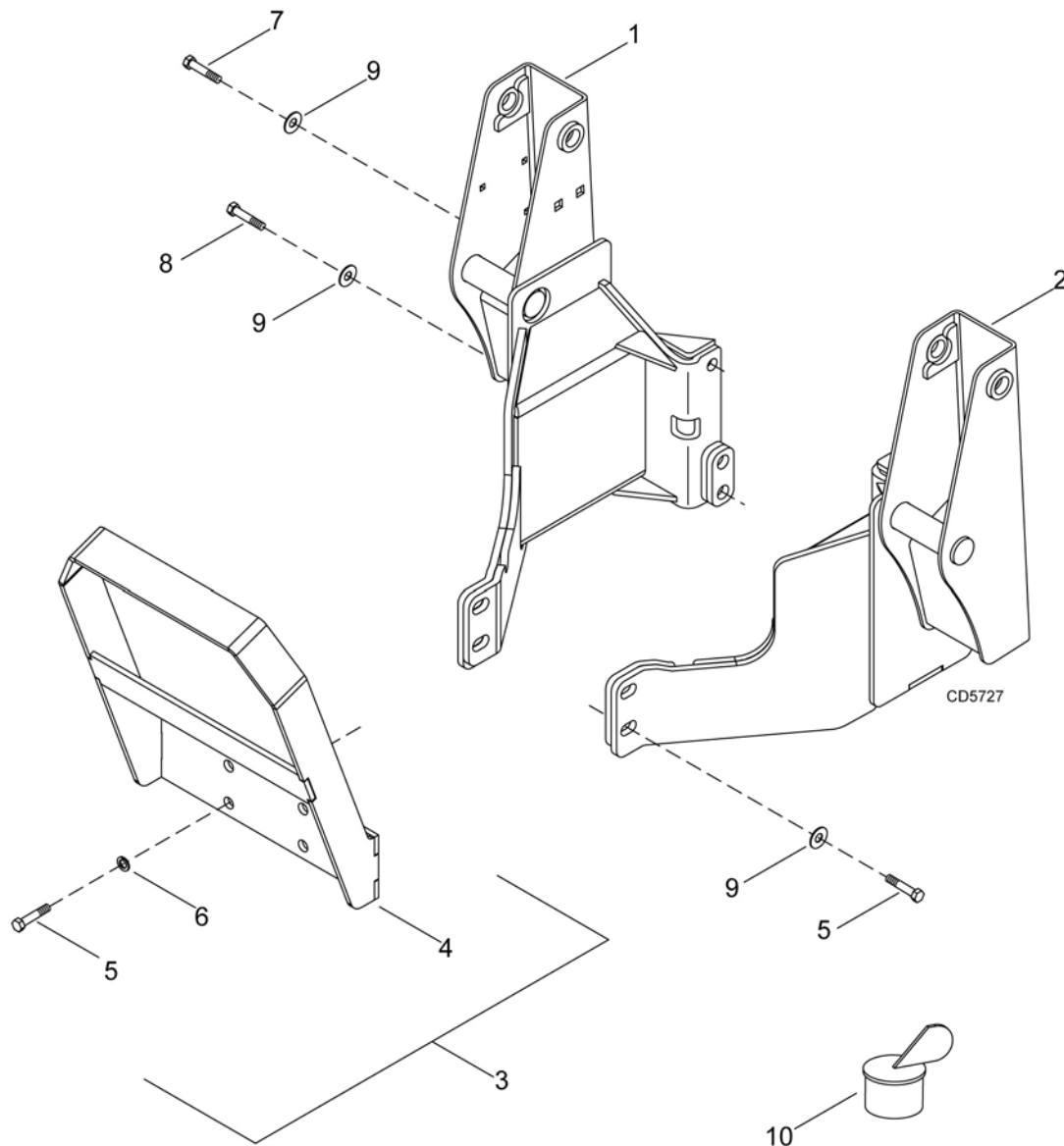

REF	PART	QTY	DESCRIPTION
1	1000468	1	Right rear mount
2	1000469	1	Left rear mount
3	40448	1	Grill guard kit (optional; included items 4-6)
4	40449	1	Grill guard
5	307553	8	M20 x 2.5 x 50 mm HHCS

REF	PART	QTY	DESCRIPTION
6	21531	4	M20 Lock washer
7	1001377	2	M20 x 2.5 x 40 mm HHCS CL10.9
8	21413	4	M20 x 2.5 x 70 mm HHCS CL10.9
9	57798	10	3/4 Hardened flat washer
10	1010461	1	Exhaust weather cap 2.25 - 2.43

HHCS Hex Head Cap Screw

* Standard hardware, obtain locally

28 Parts

MAN0041 (Rev. 4/4/2008)

1010460 HOSE KIT

1020, 1027 LOADERS

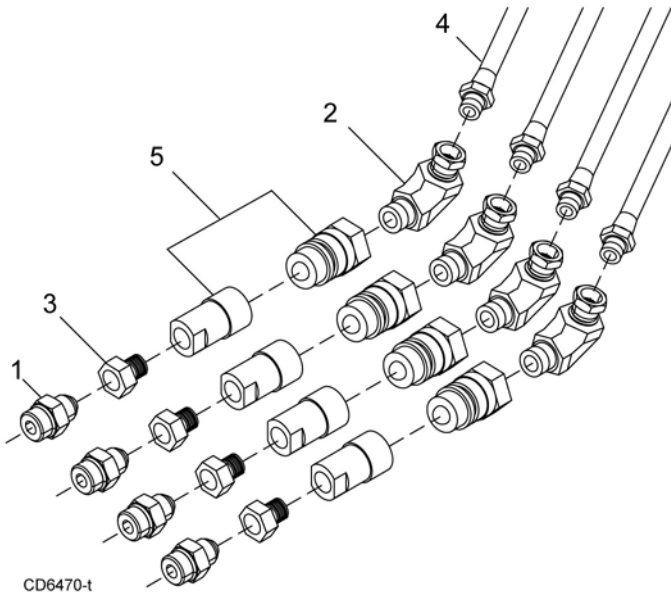

REF	PART	QTY	DESCRIPTION
1	1010920	4	Adapter, M22 x 1.5 x 3/4 JICM
1	1012055	4	Adapter, M18 x 1.5 x 3/4 JICM
2	313015	4	Elbow, 3/8 NPTM x 3/8 NPTF 45°
3	315036	4	Adapter, 3/8 NPTM x 3/4 JICF
4	1009513	4	Hose, 76" x 3/8 NPTM x 3/4 JICM
5	316007	4	Quick coupler set, male & female
NS	395061	2	Spiral band, plastic - Red
NS	395062	2	Spiral band, plastic - Blue
NS	395063	2	Spiral band, plastic - Orange
NS	88 *	3	Plastic tie (TY-RAP)

* Standard hardware, obtain locally

NS Not Shown

1023577 HOSE KIT

LU126, LU132 LOADERS

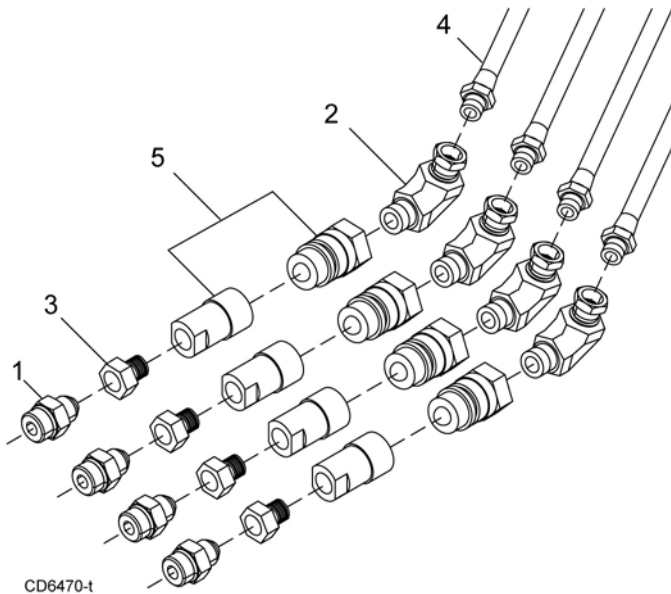

REF	PART	QTY	DESCRIPTION
1	1010920	4	Adapter, M22 x 1.5 x 3/4 JICM
1	1012055	4	Adapter, M18 x 1.5 x 3/4 JICM
2	313015	4	Elbow, 3/8 NPTM x 3/8 NPTF 45°
3	315036	4	Adapter, 3/8 NPTM x 3/4 JICF
4	1022986	4	Hose, 116" x 3/8 NPTM x 3/4 JICM
5	316007	4	Quick coupler set, male & female
NS	395061	2	Spiral band, plastic - Red
NS	395062	2	Spiral band, plastic - Blue
NS	395063	2	Spiral band, plastic - Orange
NS	88 *	3	Plastic tie (TY-RAP)

* Standard hardware, obtain locally

NS Not Shown

46945 HOSE KIT

1020, 1027 LOADERS

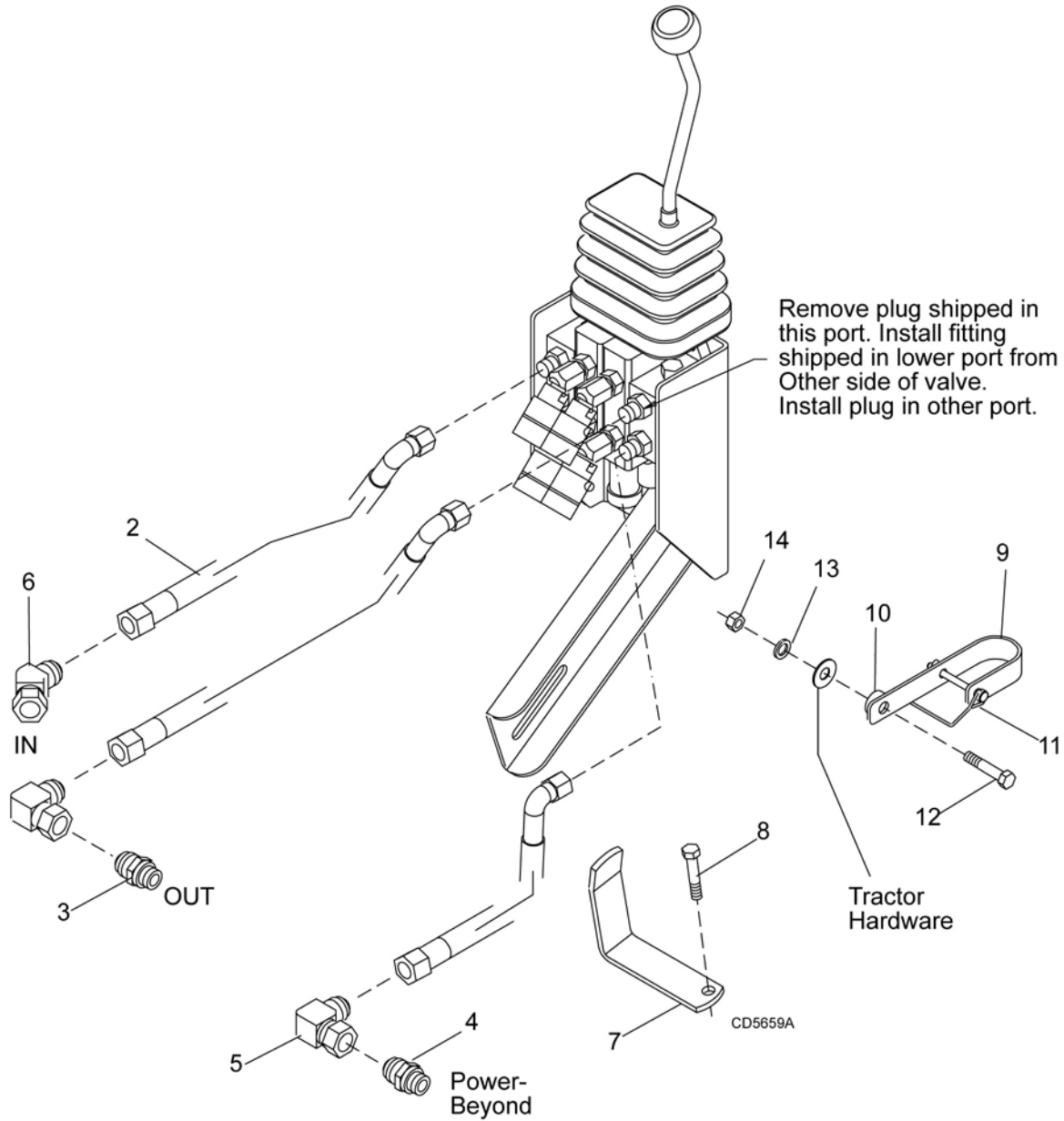

REF	PART	QTY	DESCRIPTION
2	46947	3	Hose, 120" x 3/4 JICF x 7/8 JICF
3	58081	1	Adapter, M22 x 1.5M x 7/8 JICM
4	58647	1	Adapter, M18 x 1.5M x 7/8 JICM
5	315024	2	Elbow, 7/8 JICM x 7/8 JICF
6	46054	1	Elbow, 7/8 JICM x 7/8 JICF 45°
7	54305	1	Hose guide
8	307203	1	M10 x 1.25P x 35 mm HHCS

REF	PART	QTY	DESCRIPTION
9	58280	1	Hose hanger
10	46948	1	Spacer, .62 x .84 x .38
11	58047	1	1/4 x 2-1/2 Lock pin
12	31138 *	1	3/8 NC x 3-1/2 HHCS
13	838 *	1	3/8 Lock washer
14	835 *	1	3/8 NC Hex nut
15	88 *	6	Plastic ties (not shown)

HHCS Hex Head Cap Screw

* Standard hardware, obtain locally

30 Parts

MAN0041 (Rev. 4/4/2008)

1023583 HOSE KIT

LU126, LU132 LOADERS

NOTE: Not all parts supplied with this hose kit are used for this application.

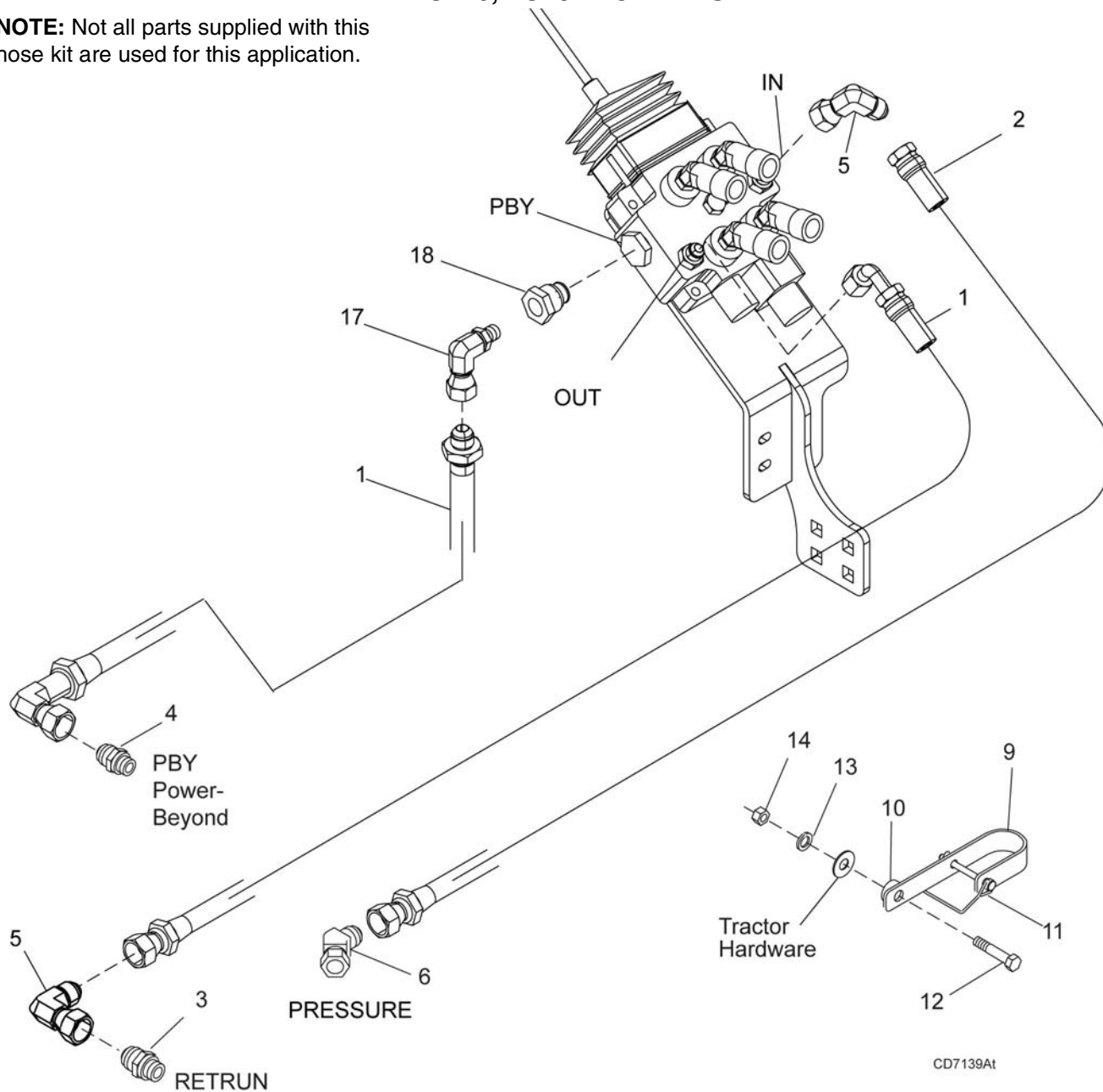

REF	PART	QTY	DESCRIPTION
1	1002862	2	Hose, 120" x 3/4 JICF x 3/4 JICF 90°
2	1023496	1	Hose, 120" x 3/4 JICF x 7/8 JICF
3	1010920	1	Adapter, M22 x 1.5P x 3/4 JICM
4	44426	1	Adapter, M18 x 1.5P x 3/4 JICM
5	313032	2	Elbow, 3/4 JICM x 3/4 JICF 90°
6	46054	1	Elbow, 7/8 JICFM x 7/8 JICF 45°
9	58280	1	Hose Bracket
10	46948	1	Spacer, .62 x .84 x .38
11	58047	1	Pin, lock 1/4 x 2-1/4

REF	PART	QTY	DESCRIPTION
12	31138 *	1	3/8 NC x 3-1/2 HHCS
13	838 *	1	3/8 Lock washer
14	835 *	1	3/8 NC Hex nut
15	88 *	6	Plastic tie (not shown)
17	60	1	Elbow, 3/4 JICM x 7/8 ORBM
18	346143	1	PBY conversion plug

HHCS Hex Head Cap Screw

* Standard hardware, obtain locally

58025 HOSE KIT

1020, 1027 LOADERS

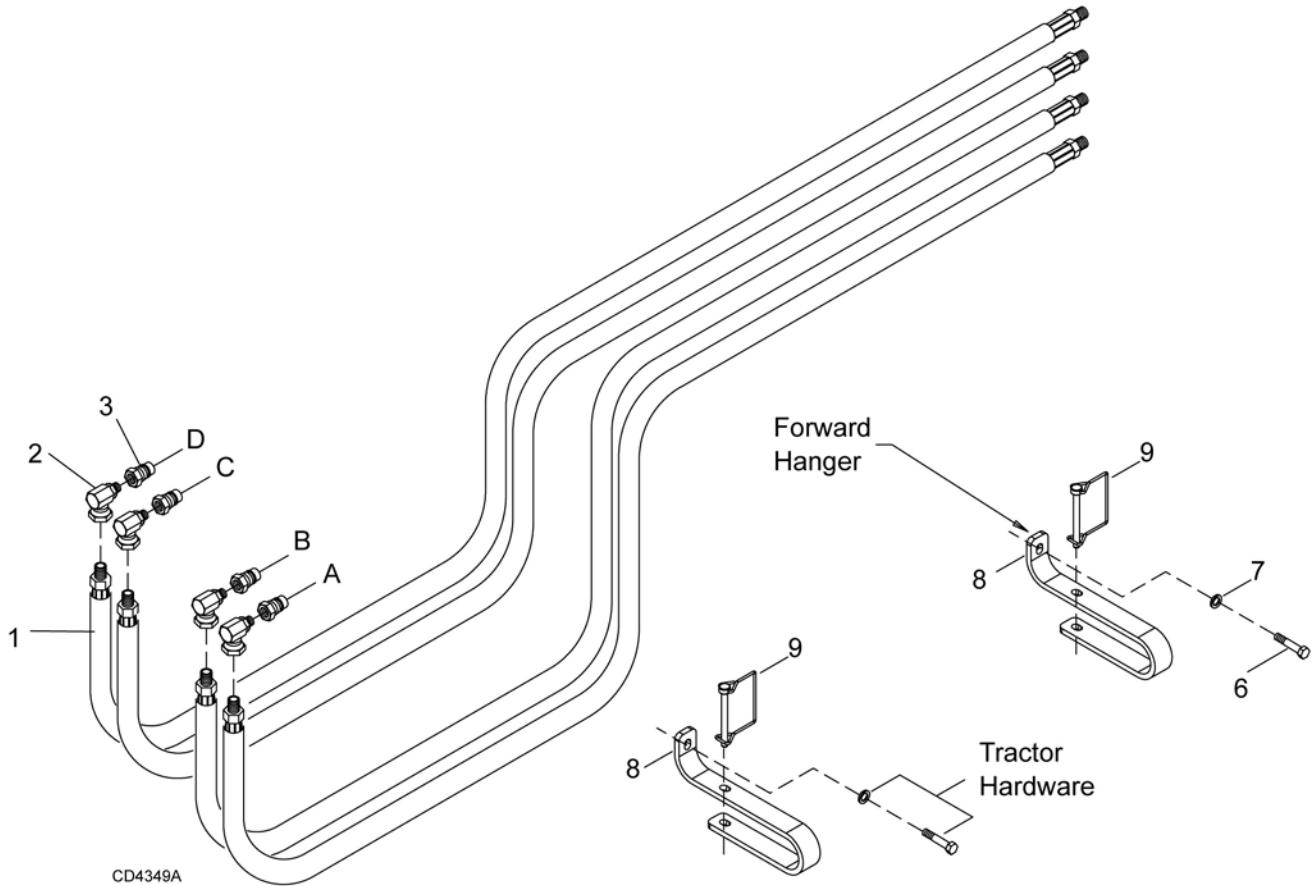

REF	PART	QTY	DESCRIPTION
1	53670	4	Hose, 150" x 3/4 JICM x 3/4 JICM
2	313053	4	Elbow, 3/4 JICF x 1/2 NPTM 90°
3	66511	4	Quick coupler, Male 1/2" (not included in kit)
6	30577	1	M8 x 1.25P x 25 mm HHCS GR8.8
7	2472 *	1	5/16 Lock washer
8	58033	2	Hose hanger
9	58047	2	1/4 x 2-1/2 Lock pin

REF	PART	QTY	DESCRIPTION
NS	58677	1	Support bracket (not used)
NS	54305	1	Hose guide bracket (not used)
NS	89 *		Nylon cable ties
NS	395061	2	Spiral band, red
NS	395062	2	Spiral band, blue
NS	395063	2	Spiral band, orange
NS	54124	2	Spiral band, white

NS Not shown

HHCS Hex Head Cap Screw

* Standard hardware, obtain locally

32 Parts

MAN0041 (Rev. 4/4/2008)

1023584 HOSE KIT

LU126, LU132 LOADERS

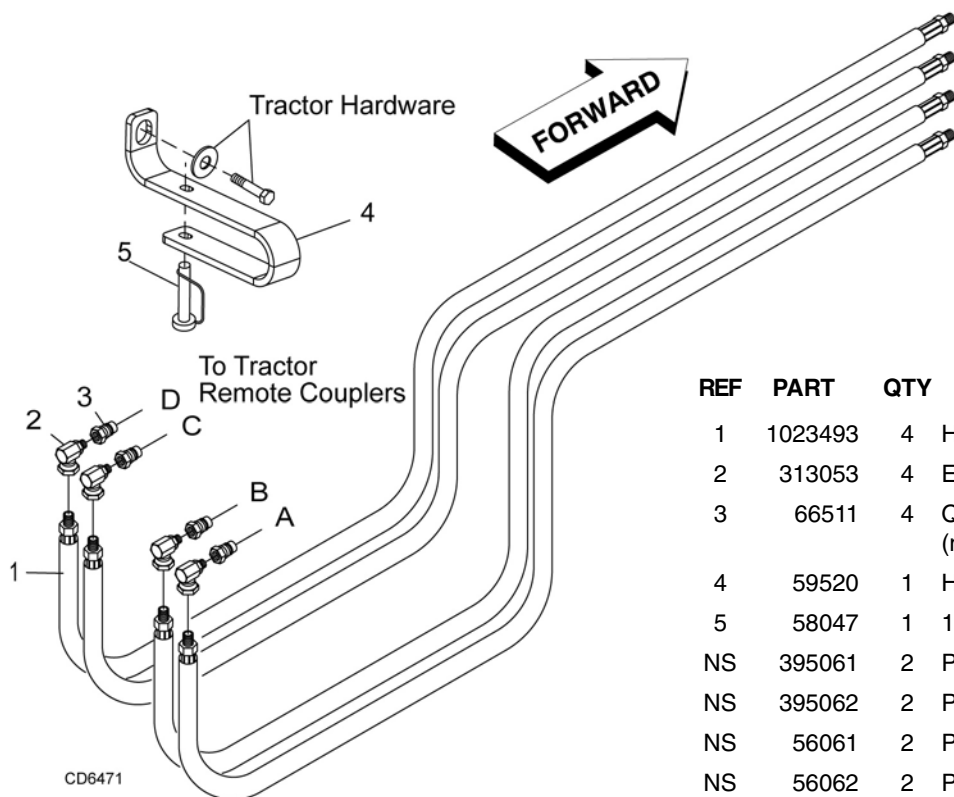

LU126 / LU132

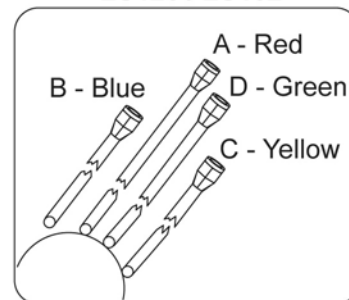

LOADER FEEDLINES

REF	PART	QTY	DESCRIPTION
1	1023493	4	Hose, 200" x 3/4 JICM x 3/4 JICM
2	313053	4	Elbow, 3/4 JICF x 1/2 NPTF 90°
3	66511	4	Quick coupler, Male 1/2" (not included in kit)
4	59520	1	Hose hanger bracket
5	58047	1	1/4 x 2-1/2 Lock pin
NS	395061	2	Plastic band, Red
NS	395062	2	Plastic band, Blue
NS	56061	2	Plastic band, Green
NS	56062	2	Plastic band, Yellow
NS	88 *		Plastic tie

NOTE: Not all parts supplied with this hose kit are used for this application.

NS Not shown

* Standard hardware, obtain locally

BOLT TORQUE CHART

Always tighten hardware to these values unless a different torque value or tightening procedure is listed for a specific application.

Fasteners must always be replaced with the same grade as specified in the manual parts list.

Always use the proper tool for tightening hardware: SAE for SAE hardware and Metric for metric hardware.

Make sure fastener threads are clean and you start thread engagement properly.

All torque values are given to specifications used on hardware defined by SAE J1701 MAR 99 & J1701M JUL 96.

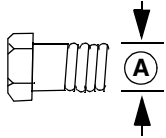

SAE SERIES TORQUE CHART



SAE Grade 2
(No Dashes)

SAE Bolt Head Identification



SAE Grade 5
(3 Radial Dashes)



SAE Grade 8
(6 Radial Dashes)

Ⓐ Diameter (Inches)	Wrench Size	MARKING ON HEAD					
		SAE 2		SAE 5		SAE 8	
		lbs-ft	N-m	lbs-ft	N-m	lbs-ft	N-m
1/4"	7/16"	6	8	10	13	14	18
5/16"	1/2"	12	17	19	26	27	37
3/8"	9/16"	23	31	35	47	49	67
7/16"	5/8"	36	48	55	75	78	106
1/2"	3/4"	55	75	85	115	120	163
9/16"	13/16"	78	106	121	164	171	232
5/8"	15/16"	110	149	170	230	240	325
3/4"	1-1/8"	192	261	297	403	420	569
7/8"	1-5/16"	306	416	474	642	669	907
1"	1-1/2"	467	634	722	979	1020	1383

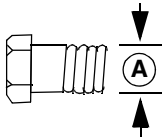

METRIC SERIES TORQUE CHART



Metric
Grade 8.8

Metric Bolt Head Identification



Metric
Grade 10.9

Ⓐ Diameter & Thread Pitch (Millimeters)	Wrench Size	COARSE THREAD				FINE THREAD				Ⓐ Diameter & Thread Pitch (Millimeters)
		MARKING ON HEAD								
		Metric 8.8		Metric 10.9		Metric 8.8		Metric 10.9		
		N-m	lbs-ft	N-m	lbs-ft	N-m	lbs-ft	N-m	lbs-ft	
6 x 1.0	10 mm	8	6	11	8	8	6	11	8	6 x 1.0
8 x 1.25	13 mm	20	15	27	20	21	16	29	22	8 x 1.0
10 x 1.5	16 mm	39	29	54	40	41	30	57	42	10 x 1.25
12 x 1.75	18 mm	68	50	94	70	75	55	103	76	12 x 1.25
14 x 2.0	21 mm	109	80	151	111	118	87	163	120	14 x 1.5
16 x 2.0	24 mm	169	125	234	173	181	133	250	184	16 x 1.5
18 x 2.5	27 mm	234	172	323	239	263	194	363	268	18 x 1.5
20 x 2.5	30 mm	330	244	457	337	367	270	507	374	20 x 1.5
22 x 2.5	34 mm	451	332	623	460	495	365	684	505	22 x 1.5
24 x 3.0	36 mm	571	421	790	583	623	459	861	635	24 x 2.0
30 x 3.0	46 mm	1175	867	1626	1199	1258	928	1740	1283	30 x 2.0

Typical Washer Installations

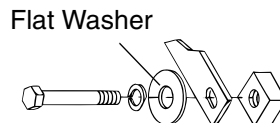
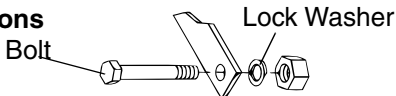

8/9/00

BOLT SIZE CHART

NOTE: Chart shows bolt thread sizes and corresponding head (wrench) sizes for standard SAE and metric bolts.

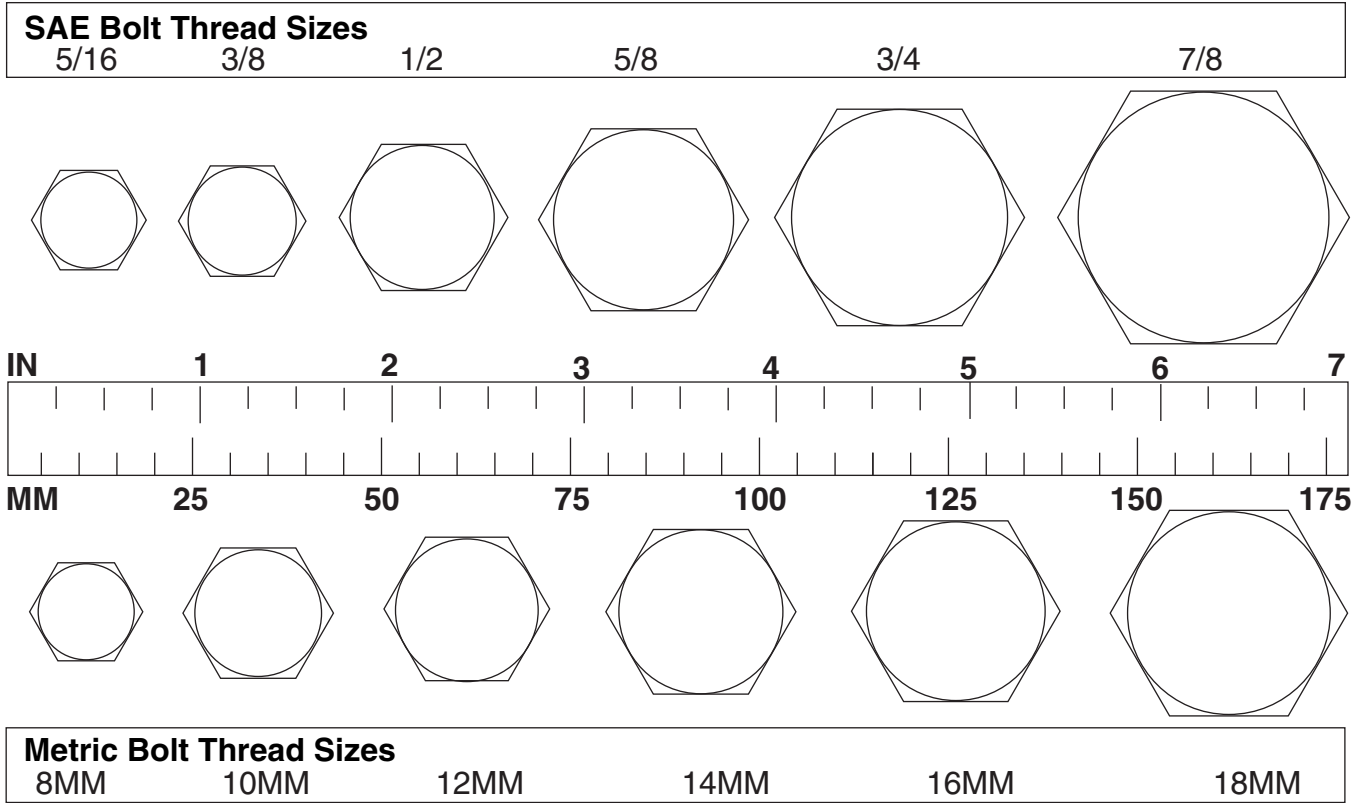

ABBREVIATIONS

AG	Agriculture	MPa.....	Mega Pascal
ASABE.....	American Society of Agricultural & Biological Engineers (formerly ASAE)	N.....	Newton
ASAE	American Society of Agricultural Engineers	NC	National Coarse
ATF	Automatic Transmission Fluid	NF	National Fine
BSPP	British Standard Pipe Parallel	NPSM.....	National Pipe Straight Mechanical
BSPTM	British Standard Pipe Tapered Male	NPT	National Pipe Tapered
CV.....	Constant Velocity	NPT SWF	National Pipe Tapered Swivel Female
CCW	Counter-Clockwise	ORBM	O-Ring Boss - Male
CW.....	Clockwise	P.....	Pitch
F	Female	PBY	Power-Beyond
FT	Full Thread	psi.....	Pounds per Square Inch
GA	Gauge	PTO	Power Take Off
GR (5, etc.)	Grade (5, etc.)	QD.....	Quick Disconnect
HHCS	Hex Head Cap Screw	RH.....	Right Hand
HT.....	Heat-Treated	ROPS	Roll-Over Protective Structure
JIC	Joint Industry Council 37° Degree Flare	RPM	Revolutions Per Minute
LH.....	Left Hand	RT	Right
LT.....	Left	SAE	Society of Automotive Engineers
m.....	Meter	UNC	Unified Coarse
mm.....	Millimeter	UNF	Unified Fine
M.....	Male	UNS.....	Unified Special



WARRANTY

(Replacement Parts For All Models Except Mow'n Machine™
Zero-Turn Mowers and Woods Boundary™ Utility Vehicles)

Woods Equipment Company ("WOODS") warrants this product to be free from defect in material and workmanship for a period of ninety (90) days from the date of delivery of the product to the original purchaser with the exception of V-belts, which will be free of defect in material and workmanship for a period of 12 months.

Under no circumstances will this Warranty apply in the event that the product, in the good faith opinion of WOODS, has been subjected to improper operation, improper maintenance, misuse, or an accident. This Warranty does not cover normal wear or tear, or normal maintenance items.

This Warranty is extended solely to the original purchaser of the product. Should the original purchaser sell or otherwise transfer this product to a third party, this Warranty does not transfer to the third party purchaser in any way. There are no third party beneficiaries of this Warranty.

WOODS' obligation under this Warranty is limited to, at WOODS' option, the repair or replacement, free of charge, of the product if WOODS, in its sole discretion, deems it to be defective or in noncompliance with this Warranty. **The product must be returned to WOODS with proof of purchase within thirty (30) days after such defect or noncompliance is discovered or should have been discovered, routed through the dealer and distributor from whom the purchase was made, transportation charges prepaid.** WOODS shall complete such repair or replacement within a reasonable time after WOODS receives the product. THERE ARE NO OTHER REMEDIES UNDER THIS WARRANTY. THE REMEDY OF REPAIR OR REPLACEMENT IS THE SOLE AND EXCLUSIVE REMEDY UNDER THIS WARRANTY.

THERE ARE NO WARRANTIES WHICH EXTEND BEYOND THE DESCRIPTION ON THE FACE OF THIS WARRANTY. WOODS MAKES NO OTHER WARRANTY, EXPRESS OR IMPLIED, AND WOODS SPECIFICALLY DISCLAIMS ANY IMPLIED WARRANTY OF MERCHANTABILITY AND/OR ANY IMPLIED WARRANTY OF FITNESS FOR A PARTICULAR PURPOSE.

WOODS shall not be liable for any incidental or consequential losses, damages or expenses, arising directly or indirectly from the product, whether such claim is based upon breach of contract, breach of warranty, negligence, strict liability in tort or any other legal theory. Without limiting the generality of the foregoing, Woods specifically disclaims any damages relating to (i) lost profits, business, revenues or goodwill; (ii) loss of crops; (iii) loss because of delay in harvesting; (iv) any expense or loss incurred for labor, supplies, substitute machinery or rental; or (v) any other type of damage to property or economic loss.

This Warranty is subject to any existing conditions of supply which may directly affect WOODS' ability to obtain materials or manufacture replacement parts.

No agent, representative, dealer, distributor, service person, salesperson, or employee of any company, including without limitation, WOODS, its authorized dealers, distributors, and service centers, is authorized to alter, modify, or enlarge this Warranty.

Answers to any questions regarding warranty service and locations may be obtained by contacting:

Woods Equipment Company

2606 South Illinois Route 2
Post Office Box 1000
Oregon IL 61061

800-319-6637 tel
800-399-6637 fax
www.WoodsEquipment.com

WOODS®

ALITEC™

BMP®

CENTRAL FABRICATORS®

GANNON®

GILL®

WAIN-ROY®

WOODS®

WARRANTY

(All Models Except Mow'n Machine™ Zero-Turn Mowers and Woods Boundary™ Utility Vehicles)

Please Enter Information Below and Save for Future Reference.

Date Purchased: _____ From (Dealer): _____
 Model Number: _____ Serial Number: _____

Woods Equipment Company ("WOODS") warrants this product to be free from defect in material and workmanship. Except as otherwise set forth below, the duration of this Warranty shall be for TWELVE (12) MONTHS COMMENCING ON THE DATE OF DELIVERY OF THE PRODUCT TO THE ORIGINAL PURCHASER.

Woods backhoe models BH70-X, BH80-X, and BH90-X are warranted for two (2) years from the date of delivery to the original purchaser.

The warranty periods for specific parts or conditions are listed below:

Part or Condition Warranted	Model Number	Duration (from date of delivery to the original purchaser)
Gearbox components	BW1260, BW1800	8 years
	BB48X, BB60X, BB72X, BB84X, BB600X, BB720X, BB840X, BB6000X, BB7200X, BB8400X, DS1260, DSO1260, DS1440, TS1680, BW126-2, BW180-2	6 years
	PHD25, PHD35, PHD65, PHD95, 2162, 3240, DS96, DS120, RCC42, RM550-2, RM660-2, RM990-3, PRD6000, PRD7200, PRD8400, 7144RD-2, 9180RD-2, 9204RD-2, S15CD, S20CD, S22CD, S25CD, S27CD	5 years
	RDC54, RD60, RD72	3 years (1 year if used in rental or commercial applications)
Blade spindles	RM550-2, RM660-2, RM990-3, PRD6000, PRD7200, PRD8400, 7144RD-2, 9180RD-2, 9204RD-2	3 years
Rust-through	BB600, BB720, BB840, BB6000, BB7200, BB8400, BW126-2, BW180-2, BW1260, BW1800, 2162, 3240, DS1260, DSO1260, DS1440, TS1680	10 years

Under no circumstances will this Warranty apply in the event that the product, in the good faith opinion of WOODS, has been subjected to improper operation, improper maintenance, misuse, or an accident. This Warranty does not apply in the event that the product has been materially modified or repaired by someone other than WOODS, a WOODS authorized dealer or distributor, and/or a WOODS authorized service center. This Warranty does not cover normal wear or tear, or normal maintenance items. This Warranty also does not cover repairs made with parts other than those obtainable through WOODS.

This Warranty is extended solely to the original purchaser of the product. Should the original purchaser sell or otherwise transfer this product to a third party, this Warranty does not transfer to the third party purchaser in any way. There are no third party beneficiaries of this Warranty.

WOODS makes no warranty, express or implied, with respect to engines, batteries, tires or other parts or accessories not manufactured by WOODS. Warranties for these items, if any, are provided separately by their respective manufacturers.

WOODS' obligation under this Warranty is limited to, at WOODS' option, the repair or replacement, free of charge, of the product if WOODS, in its sole discretion, deems it to be defective or in noncompliance with this Warranty. **The product must be returned to WOODS with proof of purchase within thirty (30) days after such defect or noncompliance is discovered or should have been discovered, routed through the dealer and distributor from whom the purchase was made, transportation charges prepaid.** WOODS shall complete such repair or replacement within a reasonable time after WOODS receives the product. **THERE ARE NO OTHER REMEDIES UNDER THIS WARRANTY. THE REMEDY OF REPAIR OR REPLACEMENT IS THE SOLE AND EXCLUSIVE REMEDY UNDER THIS WARRANTY.**

THERE ARE NO WARRANTIES WHICH EXTEND BEYOND THE DESCRIPTION ON THE FACE OF THIS WARRANTY. WOODS MAKES NO OTHER WARRANTY, EXPRESS OR IMPLIED, AND WOODS SPECIFICALLY DISCLAIMS ANY IMPLIED WARRANTY OF MERCHANTABILITY AND/OR ANY IMPLIED WARRANTY OF FITNESS FOR A PARTICULAR PURPOSE.

WOODS shall not be liable for any incidental or consequential losses, damages or expenses, arising directly or indirectly from the product, whether such claim is based upon breach of contract, breach of warranty, negligence, strict liability in tort or any other legal theory. Without limiting the generality of the foregoing, Woods specifically disclaims any damages relating to (i) lost profits, business, revenues or goodwill; (ii) loss of crops; (iii) loss because of delay in harvesting; (iv) any expense or loss incurred for labor, supplies, substitute machinery or rental; or (v) any other type of damage to property or economic loss.

This Warranty is subject to any existing conditions of supply which may directly affect WOODS' ability to obtain materials or manufacture replacement parts.

No agent, representative, dealer, distributor, serviceperson, salesperson, or employee of any company, including without limitation, WOODS, its authorized dealers, distributors, and service centers, is authorized to alter, modify, or enlarge this Warranty.

Answers to any questions regarding warranty service and locations may be obtained by contacting:

Woods Equipment Company
 2606 South Illinois Route 2
 Post Office Box 1000
 Oregon IL 61061
 800-319-6637 tel
 800-399-6637 fax
 www.WoodsEquipment.com



ALITEC™
BMP®
CENTRAL FABRICATORS®
GANNON®
GILL®
WAIN-ROY®
WOODS®

PART NO.
MAN0041

**Woods Equipment
Company**

2606 South Illinois Route 2
Post Office Box 1000
Oregon, Illinois 61061

800-319-6637 tel
800-399-6637 fax
www.WoodsEquipment.com

WOODS®