

Service and Maintenance Instructions For Sizes 065-150 Series 130

NOTE: Read the entire instruction manual before starting the installation.

These procedures are for sizes 65,000 through 150,000 Btuh units.
Index Page

| | |
|-------------------------------------|-----|
| SAFETY CONSIDERATIONS | 1 |
| CARE AND MAINTENANCE..... | 1-4 |
| Air Filter Arrangement | 2 |
| Blower Motor and Wheel..... | 2-3 |
| Cleaning Heat Exchanger..... | 3-4 |
| Electrical Controls and Wiring..... | 4 |
| Pilot | 4 |
| Troubleshooting | 4 |
| Unit Wiring Diagram | 5-6 |
| Troubleshooting Chart | 7 |

SAFETY CONSIDERATIONS

Installing and servicing heating equipment can be hazardous due to gas and electrical components. Only trained and qualified personnel should install, repair, or service heating equipment.

Untrained personnel can perform basic maintenance functions such as cleaning and replacing air filters. All other operations must be performed by trained service personnel. When working on heating equipment, observe precautions in the literature, on tags, and on labels attached to or shipped with the unit and other safety precautions that may apply.

Follow all safety codes. In the United States, follow all safety codes including the National Fuel Gas Code NFPA No. 54-1992/ANSI Z223.1-1992 (NFGC). In Canada, refer to the current edition of the National Standard of Canada CAN/CGA-B149.1- and .2-M95 Natural Gas and Propane Gas Installation Codes (NSCNGPIC). Wear safety glasses and work gloves. Have fire extinguisher available during start-up and adjustment procedures and service calls.

Recognize safety information. This is the safety-alert symbol . When you see this symbol on the furnace and in instructions or manuals, be alert to the potential for personal injury.

Understand the signal word DANGER, WARNING, or CAUTION. These words are used with the safety-alert symbol. DANGER identifies the most serious hazards which **will** result in severe personal injury or death. WARNING signifies a hazard that **could** result in personal injury or death. CAUTION is used to identify unsafe practices which **would** result in minor personal injury or product and property damage. NOTE is used to highlight suggestions that **will** result in enhanced installation, reliability, or operation.

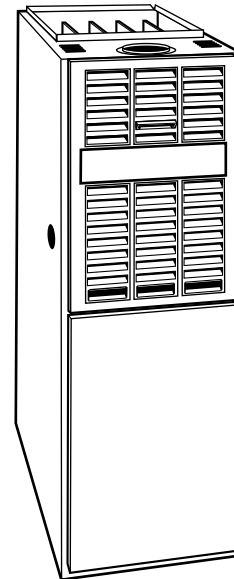

Fig. 1—Model 58GFA Upflow

A92057

⚠ WARNING

The ability to properly perform maintenance on this equipment requires certain expertise, mechanical skills, tools and equipment. If you do not possess these, do not attempt to perform any maintenance on this equipment other than those procedures recommended in the User's Manual. **FAILURE TO FOLLOW THIS WARNING COULD RESULT IN POSSIBLE DAMAGE TO THIS EQUIPMENT, SERIOUS PERSONAL INJURY, OR DEATH.**

CARE AND MAINTENANCE

For continuing high performance and to minimize possible equipment failure, it is essential that periodic maintenance be performed on this equipment. Consult your local dealer as to the proper frequency of maintenance and the availability of a maintenance contract.

⚠ WARNING

Turn off the gas and electrical supplies to the unit before performing any maintenance or service. Follow the operating instructions on the label attached to the furnace. A failure to follow this warning could result in personal injury.

⚠ WARNING

Never store anything on, near, or in contact with the furnace, such as:

1. Spray or aerosol cans, rags, brooms, dust mops, vacuum cleaners or other cleaning tools.
2. Soap powders, bleaches, waxes or other cleaning compounds, plastic or plastic containers, gasoline, kerosene, cigarette lighter fluid, dry cleaning fluids or other volatile fluids.
3. Paint thinners and other painting compounds, paper bags or other paper products.

A failure to follow this warning could result in corrosion of the heat exchanger, fire, personal injury, or death.

The minimum maintenance that should be performed on this equipment is as follows:

1. Check and clean air filter each month or more frequently if required. Replace if torn.
2. Check blower motor and wheel for cleanliness and lubrication each heating and cooling season. Clean and lubricate as necessary.
3. Check electrical connections for tightness and controls for proper operation each heating season. Service as necessary.

⚠ CAUTION

As with any mechanical equipment, personal injury can result from sharp metal edges, etc., therefore, be careful when removing parts.

AIR FILTER ARRANGEMENT

The air filter arrangement may vary depending on the application. Refer to Table 1 for filter size information.

Table 1—Filter Size Information (In.)

| FURNACE CASING WIDTH | FILTER QUANTITY AND SIZE | | FILTER TYPE |
|----------------------|--------------------------|------------------|-------------|
| | Side Return | Bottom Return | |
| 14-3/16 | (1) 16 X 25 X 1* | (1) 14 X 25 X 1 | Cleanable |
| 17-1/2 | (1) 16 X 25 X 1* | (1) 16 X 25 X 1 | Cleanable |
| 21 | (1) 16 X 25 X 1 | (1) 20 X 25 X 1* | Cleanable |
| 24-1/2 | (2) 16 X 25 X 1* | (1) 24 X 25 X 1 | Cleanable |

* Factory-provided with the furnace. Filters may be field modified by cutting as required.

⚠ WARNING

Never operate unit without a filter or with filter access door removed. A failure to follow this warning could result in fire, personal injury or death.

1. Each furnace requires 1 or 2 filters which are installed in the blower compartment. (See Fig. 2.)

To remove filters for cleaning or replacement, proceed as follows:

- a. Disconnect electrical power before removing access doors.
- b. Remove blower and control access doors.
- c. Release filter retainer from clip at front of furnace casing. (See Fig. 2.) For side return, clips may be used on either or both sides of the furnace.

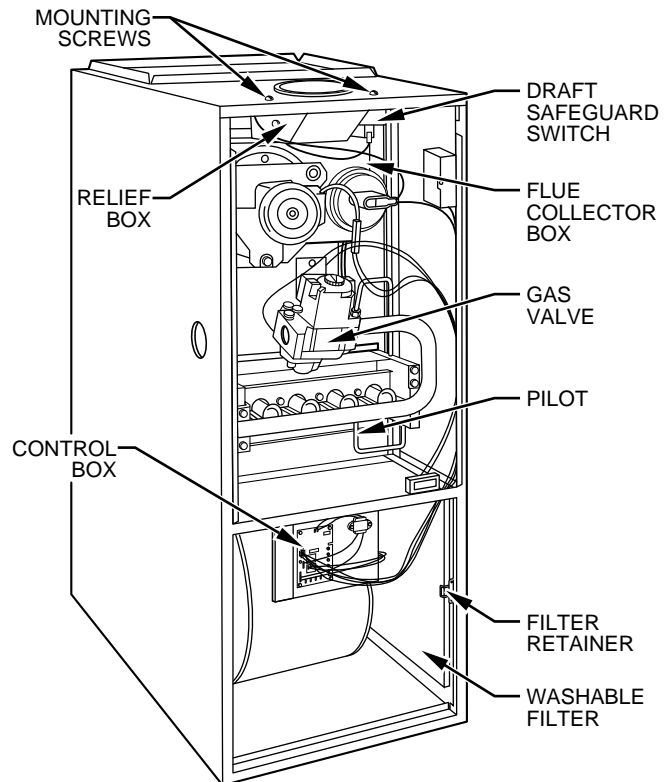

A92178

Fig. 2—Model 58GFA Upflow

- d. Slide filter out.
- e. Furnaces are equipped with permanent, washable filters. Clean filters with tap water. Spray water through filter in opposite direction of airflow.
- f. Rinse and let dry. Oiling or coating of filter is not recommended or required.
- g. Reinstall filter.
- h. Replace access doors.
- i. Restore electrical power to furnace.

BLOWER MOTOR AND WHEEL

For long life, economy, and high efficiency, clean accumulated dirt and grease from the blower wheel and motor annually.

The following steps should be performed by a qualified service technician:

Some motors have prelubricated sealed bearings and require no lubrication. These motors can be identified by the absence of oil ports on each end of the motor. For those motors with oil ports, lubricate motor every 5 years if motor is used on intermittent operation (thermostat FAN switch in AUTO position), or every 2 years if motor is in continuous operation (thermostat FAN switch in ON position).

Remember to disconnect the electrical supply before removing access doors.

Clean and lubricate as follows:

2. Remove control assembly.
3. Remove blower leads from blower assembly. Note location of wires for reassembly.
4. Remove screws holding blower assembly to blower deck and slide blower assembly out of furnace.
5. Loosen screw in strap holding motor capacitor to blower housing and slide capacitor out from under strap.

6. Mark blower wheel, motor, and motor support in relation to blower housing before disassembly to ensure proper reassembly.
7. Loosen setscrew holding blower wheel on motor shaft.
8. Remove bolts holding motor mount to blower housing and slide motor and mount out of housing. Disconnect ground wire attached to blower housing before removing motor.
9. Lubricate motor (when oil ports are provided).
 - a. Remove dust caps or plugs from oil ports located at each end of motor.
 - b. Use a good grade of SAE 20 nondetergent motor oil and put 1 teaspoon, 5 cc, 3/16 oz, or 16 to 25 drops in each oil port. Do not over-oil.
 - c. Allow time for total quantity of oil to be absorbed by each bearing.
 - d. Wipe excess oil from motor housing.
 - e. Replace dust caps or plugs on oil ports.
10. Remove blower wheel from housing.
 - a. Mark cutoff location to ensure proper reassembly.
 - b. Remove screws holding cutoff plate and remove cutoff plate from housing.
 - c. Lift blower wheel from housing through opening.
11. Clean blower wheel and motor using a vacuum cleaner with soft brush attachment. Do not remove or disturb balance weights (clips) on blower wheel blades. The blower wheel should not be dropped or bent as balance will be affected.
12. Reinstall blower wheel by reversing steps 9 a. through c. Be sure wheel is positioned for proper rotation.
13. Reassemble motor and blower by reversing steps 2 through 7. If motor has ground wire, be sure it is connected as before.

⚠ CAUTION

Be sure the motor is properly positioned in the blower housing. The motor oil ports must be at a minimum of 45° above the horizontal centerline of the motor after the blower assembly has been reinstalled in the furnace.

14. Reinstall blower assembly in furnace. Connect blower leads to blower speed selector.
15. Reinstall control assembly.
16. Turn on electrical power and check for proper rotation and speed changes between heating and cooling.
17. Replace blower access door.

CLEANING HEAT EXCHANGER

The following steps should be performed by a qualified service technician:

NOTE: Deposits of soot and carbon indicate the existence of a problem which needs to be corrected. Take action to correct the problem.

If it becomes necessary to clean the heat exchanger because of carbon deposits, soot, etc., proceed as follows:

1. Turn off gas and electrical power to furnace.
2. Remove 2 screws that secure relief box. (See Fig. 3.)
3. Disconnect wires to the following components:
 - a. Draft safeguard switch
 - b. Inducer motor
 - c. Pressure switch
 - d. Limit overtemperature switch

- e. Gas valve
 - f. Edge connector leading to control box
4. Remove 8 screws that secure flue collector box to center panel. Be careful not to damage sealant.
 5. Remove complete inducer assembly from furnace, exposing flue openings.
 6. Clean cells using field-provided small wire brush, steel spring cable, reversible electric drill, and vacuum cleaner.

- a. Assemble wire brush and steel spring cable.
 - (1.) Use 48 in. of 1/4-in. diameter high-grade steel spring cable (commonly known as drain clean-out or Roto-Rooter cable).
 - (2.) Use 1/4-in. diameter wire brush (commonly known as 25-caliber rifle cleaning brush).

NOTE: The items needed in steps (1.) and (2.) can usually be purchased at local hardware stores.

- (3.) Insert twisted wire end of brush into end of steel spring cable, and crimp tight with crimping tool or strike with ball-peen hammer. **TIGHTNESS** is very important.
 - (4.) Remove metal screw fitting from wire brush to allow insertion into cable.
- b. Clean each heat exchanger cell.
 - (1.) Attach variable-speed, reversible drill to end of steel spring cable (end opposite brush).
 - (2.) Insert brush end of cable into upper opening of cell and slowly rotate with drill. **DO NOT** force cable. Gradually insert at least 36 in. of cable into 2 upper passes of cell. (See Fig. 3.)

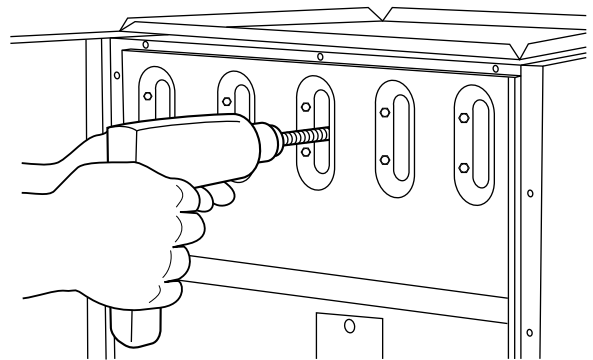

A91252

Fig. 3—Cleaning Heat Exchanger Cell

- (3.) Work cable in and out of cell 3 or 4 times to obtain sufficient cleaning. **DO NOT** pull cable with great force. Reverse drill and gradually work cable out.
- (4.) Remove burner assembly and cell inlet plates.
- (5.) Replace screws in center panel and cells before cleaning.
- (6.) Insert brush end of cable in lower opening of cell, and proceed to clean 2 lower passes of cell in same manner as 2 upper passes.
- (7.) Repeat foregoing procedures until each cell in furnace has been cleaned.
- (8.) Remove residue from each cell using vacuum cleaner.
- (9.) Clean burner assembly using vacuum cleaner with soft brush attachment.

- (10.) Reinstall cell inlet plates and burner assembly. Care must be exercised to center the burners in the cell openings.
7. After cleaning flue openings, check sealant on flue collector to ensure that it has not been damaged. If new sealant is needed, contact your dealer or distributor.
 8. Clean and replace flue collector assembly, making sure all 8 screws are secure.
 9. Reinstall 2 screws in relief box.
 10. Reconnect wires to the following components:
 - a. Draft safeguard switch
 - b. Inducer motor
 - c. Pressure switch
 - d. Limit overtemperature switch
 - e. Gas valve
 - f. Edge connector leading to control box
 11. Replace blower access doors.
 12. Turn on electrical power and gas.
 13. Set thermostat and check furnace for proper operation.

▲ WARNING

Never use a match or other open flame to check for gas leaks. Use a soap-and-water solution. A failure to follow this warning could result in fire, personal injury or death.

14. Check for gas leaks.
15. Replace control access door.

ELECTRICAL CONTROLS AND WIRING

NOTE: There may be more than 1 electrical supply to unit.

The electrical ground for 115-v wiring must be maintained properly. Refer to Fig. 5 for field wiring information and to Fig. 6 for unit wiring information.

With power disconnected to unit, check all electrical connections for tightness. Tighten all screws on electrical connections. If any smoky or burned connections are noticed, disassemble the connection, clean all parts and stripped wire, and reassemble properly and

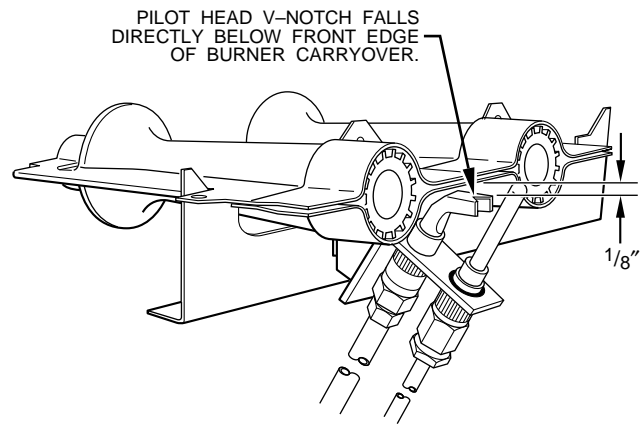

A91249

Fig. 4—Position of Pilot to Burner

securely. Electrical controls are difficult to check without proper instrumentation; therefore, reconnect electrical power to unit and observe unit through 1 complete operating cycle.

The 24-v circuit contains an automotive-type, 3-amp fuse located on the main control board. Any direct shorts during installation, service, or maintenance could cause this fuse to blow. If fuse replacement is required, use **ONLY** a 3-amp fuse of identical size.

PILOT

Check the pilot and clean if necessary at the beginning of each heating season. The pilot flame should be high enough for proper impingement of the flame sensing element (or thermocouple) and to light the burners. Remove the accumulation of soot and carbon from the flame sensing element (or thermocouple). Refer to Fig. 4 for proper location of pilot on burner assembly.

TROUBLESHOOTING

Page 7 contains a troubleshooting chart. This chart can be a useful tool in isolating furnace operation problems. Beginning with the word "Start," answer each question and follow the appropriate arrow to the next item.

The chart will help identify the problem or failed component. After replacing any component, verify correct operating sequence as indicated by bold arrows.

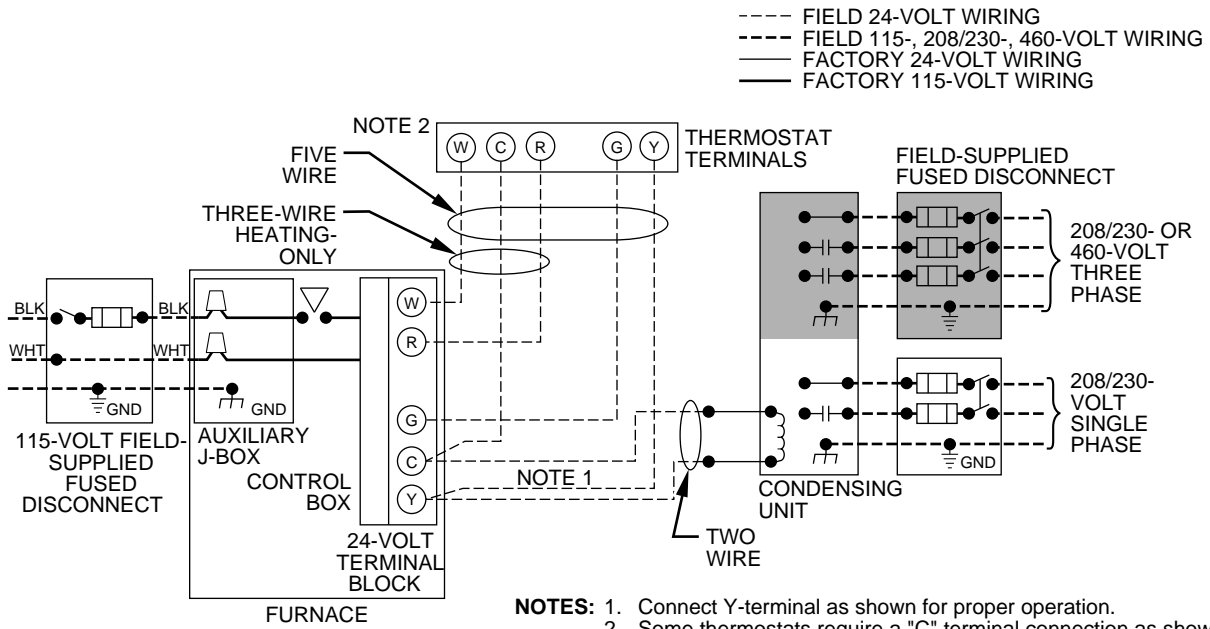

Fig. 5—Heating and Cooling Application Wiring Diagram

A95241

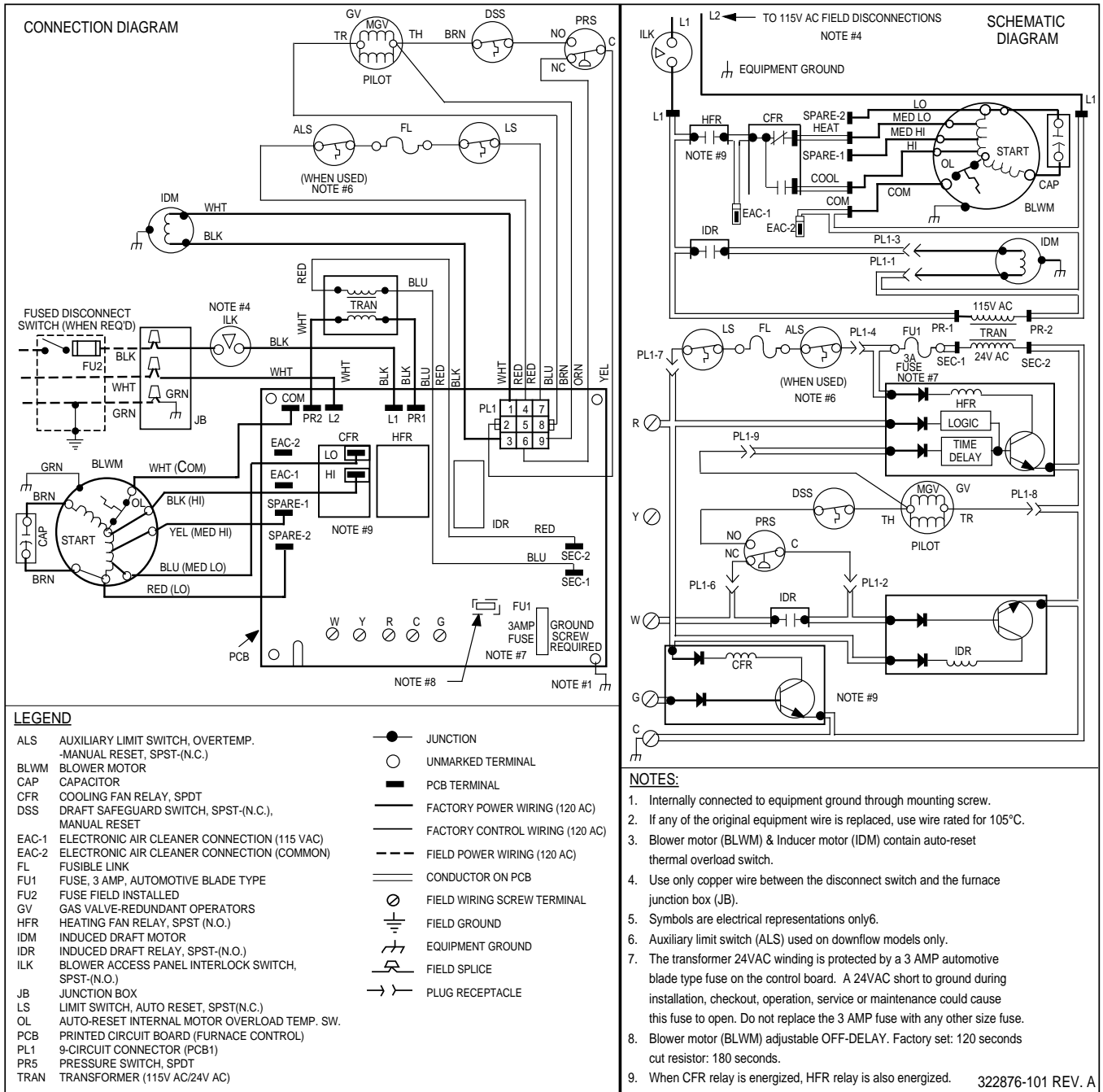
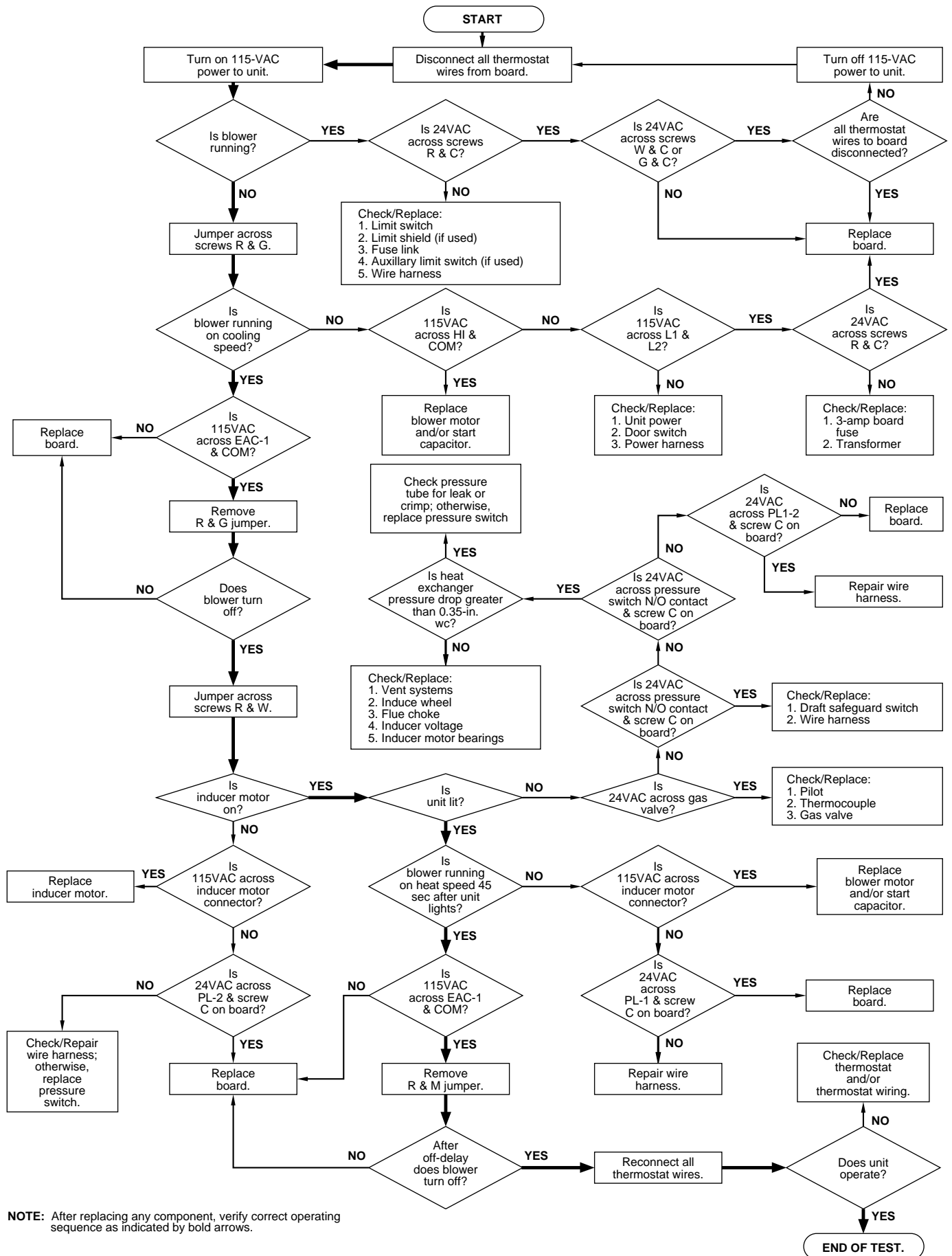

Fig. 6—Unit Wiring Diagram

A95464



SERVICE TRAINING

Packaged Service Training programs are an excellent way to increase your knowledge of the equipment discussed in this manual, including:

- Unit Familiarization
- Maintenance
- Installation Overview
- Operating Sequence

A large selection of product, theory, and skills programs is available, using popular video-based formats and materials. All include video and/or slides, plus companion book.

Classroom Service Training plus "hands-on" the products in our labs can mean increased confidence that really pays dividends in faster troubleshooting, fewer callbacks. Course descriptions and schedules are in our catalog.

CALL FOR FREE CATALOG 1-800-962-9212

Packaged Service Training Classroom Service Training

A94328